



**A Global Famous Brand  
An International Excellent Enterprise**

SUZHOU CRG ROBOTICS TECHNOLOGY CO., LTD.  
Add: No 3, Yigongchang Technology & Innovation Industrial Park, NO.581  
hengchangjing road, Zhoushi Town, Kunshan, Jiangsu, China  
Attn: Terry Pan  
Mob: +86 189 0069 2122  
Email: info@crg-eoat.com  
Web: https://crg-eoat.com

All started here is subject to change without advance notice.  
All rights reserved  
En2505



www.crg-eoat.com

CRG



6.0

END OF ARM TOOLING

COMPLEX GRIPPER FLEXIBLE ASSEMBLY

**PRODUCT CATALOGUE**

SUZHOU CRG ROBOTICS TECHNOLOGY CO.,LTD.

COMPANY INTRODUCTION

## 企业简介

CRG是一家专注于机器人及机械手末端工装夹具(EOAT)设计、开发、销售和服务的一体化高科技企业。公司产品涵盖快换装置、夹爪应用、真空及剪切技术等诸多类型的末端执行组件,广泛应用于汽车、包装、家电、食品、医疗和3C等行业;以模块化理念提供安全,可靠、简单、灵活的产品,为客户提供有效的解决方案。

CRG is an integrated high-tech enterprise focusing on the design, development, sales and service of end-of-arm tooling (EOAT) for robots and robotic manipulators. The company's products cover many types of end effector components such as quick changer devices, gripper applications, vacuum and cutting technologies, and are widely used in industries such as automotive, packaging, home appliances, food, healthcare, consumer electronics and others. With the modular concept, it provides safe, reliable, simple and flexible products and provides effective solutions for customers.



模块化设计,自由组建  
Modular design, free assembly



10,000+ 套应用案例  
3000+ 夹具配件供应  
10,000+ sets of application cases  
3000+ fixture accessories available



品质工厂 质量可靠  
Quality Factory quality is reliable

# CRG

## 企业发展



2016

苏州希瑞格机器人科技有限公司成立  
Suzhou CRG Robotics Technology Co.,Ltd.was established  
获得高新技术企业认证  
Obtained high-tech enterprise certification  
取得 ISO 质量体系认证  
Obtained ISO quality system certifications

2009

昆山永邦自动化设备有限公司成立  
Kunshan YYB Automation Equipment Co.,Ltd.  
was established



2017

设立研发中心, 建立实验室  
Set up R & D center and laboratory  
建立海外代理商  
Establish overseas agents

2019

机器人自动快换产品上市  
Robot automatic quick changer product launch



2020

投资成立苏州希埃姆智能制造有限公司  
Invested in Suzhou Xiaimu Intelligent  
Manufacturing Co.,Ltd  
投资成立武汉易欧特智能制造有限公司  
Invested in the establishment of Wuhan EOAT  
Intelligent Manufacturing Co.,LTD  
生产线自动化智能化升级改造, 提升产能  
Automate and intelligently upgrade the production  
line, and increase production capacity  
成立宁波办事处  
Establishment of the Ningbo Office



2023

获得欧盟 CE 认证  
Obtained European Union CE certification  
推出负载 800kg 自动快换及气电快插模块  
Automatic quick changer and gas and power quick plug  
modules with a load of 800kg are introduced

2022

成立青岛办事处、芜湖办事处、东莞办事处  
Established offices in Qingdao, Wuhu, and Dongguan

2025

成立合肥、日本分公司  
Establishment of a subsidiary in Hefei  
and a branch office in Japan

2026

常熟自建工厂落建, 配备5栋独立标准化产业楼, 全新自有厂区的硬件优势。企业产能、仓储、研发及办公条件全方位提升, 助力企业高质量稳步发展。  
Our self-built factory complex in Changshu, Jiangsu, features 5 independent, standardized industrial buildings. The brand-new, state-of-the-art facilities significantly enhance production capacity, warehousing, R&D, and office operations, providing a solid foundation for sustainable, high-quality growth.



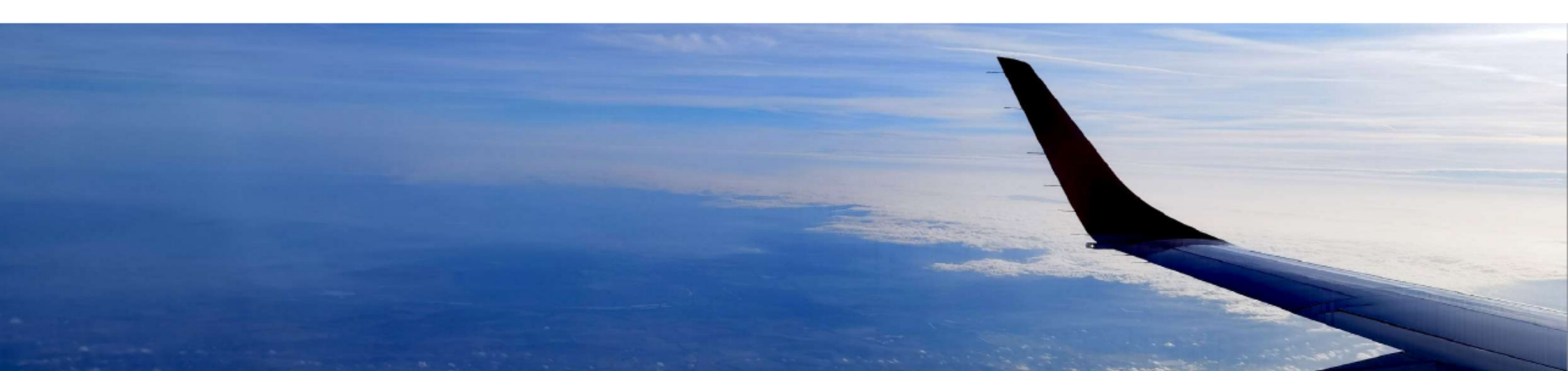

# 企业文化

CORPORATE CULTURE

## 发展使命 / Mission

为客户提供有效的解决方案，共创！共赢！共享！  
To provide customers with effective solutions and create together! Win win! Share!

## 企业愿景 / Vision

创全球知名品牌，建国际卓越企业！  
A global famous brand an international excellent enterprise!

## 经营理念 / Operation Concept

简单的事情重复做，重复的事情用心做！  
Repeating simple things, Repeating what you do attentively!



服务在手 客户在心  
Service at hand, customers at heart

高度敏锐 放眼未来  
Start from future with sensitive mind.

使命必达 全力以赴  
Do all best to achieve target.

团队合作 不屈不挠  
Work together and never give up.

勇于尝试 敢于变革  
Think out of box and open to any possibilities.

BUSINESS SCOPE

# 业务范围

## 立足中国 服务全球

Base in China Service the world

CRG 业务涵盖机器人集成应用、自动化设备和机器人末端工装夹具，  
产品远销全球 100 多个国家和地区。

CRG's business covers robot integration applications, automated equipment, and robotic end-of-arm tooling,  
with products sold to over 100 countries and regions worldwide.

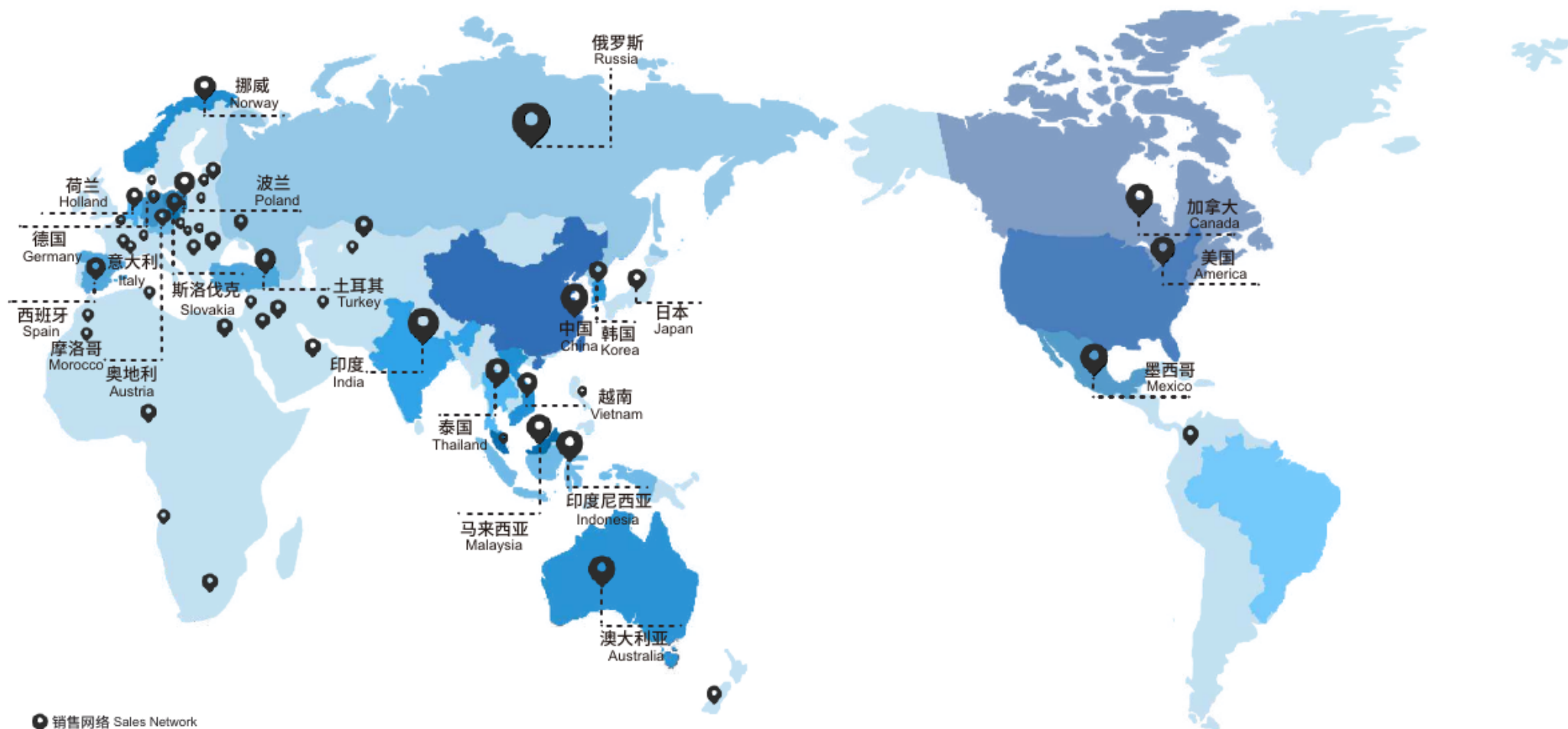

## 汽车 A 柱取出治具案例 Automotive A-pillar take out fixture case

### 产品描述：

1. 案例展示产品为一模二穴，四个料头。
2. 案例展示的产品主要采用真空吸附产品，GR20系列水口夹具取出料头。

### Product description:

1. Case display products for one mold with two cavities, four sprue.
2. The products displayed in the case mainly use vacuum adsorption products, GR20 series sprue gripper to take out the sprue.

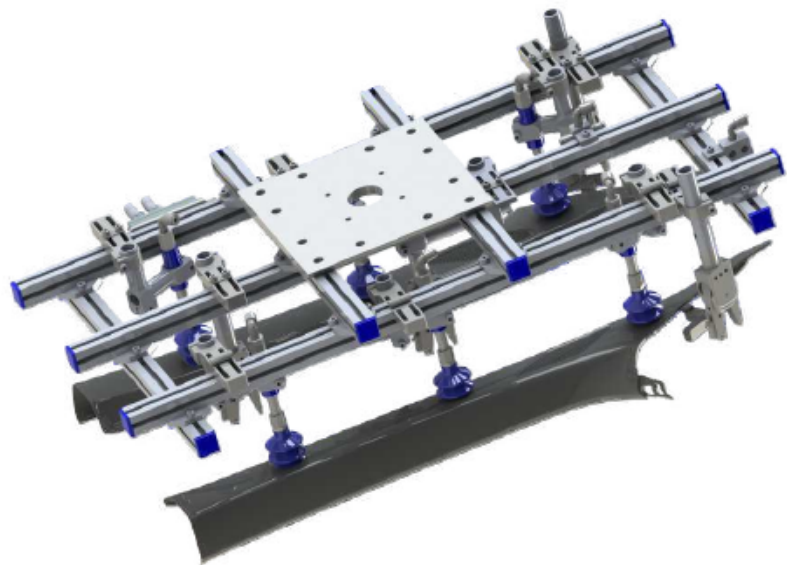

## 汽车 B 柱取出挂布治具案例 Automotive B-Pillar removal cloth fixture case

### 产品描述：

1. 案例展示产品为一模二穴，无料头。
2. 案例展示的产品采用真空吸附取出，无纺布采用 GN 针爪埋入。
3. 案例展示治具使用了方形手动快换，以达到快速更换的目的。

### Product description:

1. Case display products for one mold with two cavities, no sprue.
2. The products displayed in the case are taken out by vacuum adsorption, and the non-woven fabric is embedded by GN needle claw.
3. The case shows that the fixture uses a manual insert plate quick changer to achieve the purpose of quick changer.

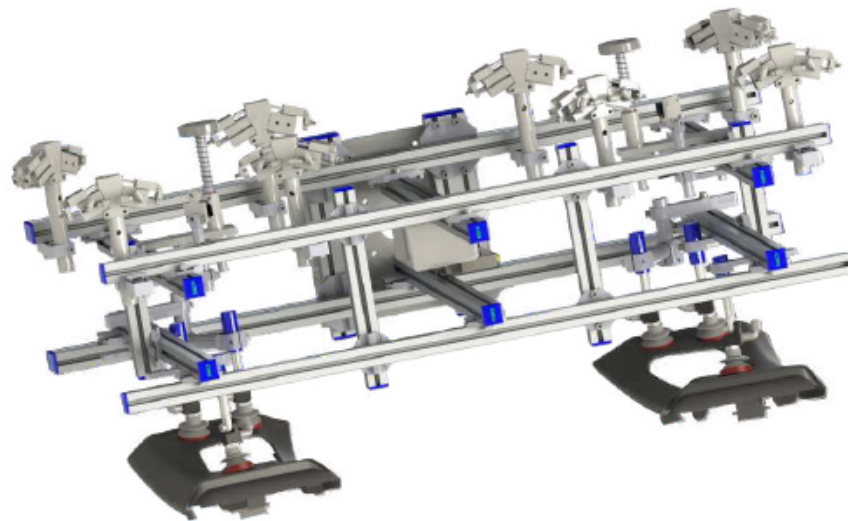

## 汽车 CD 柱手动挂布 + 取出治具案例

### Automotive CD pillar manually hanging cloth & take out fixture case

产品描述：

1. 案例产品展示为一模四穴，无料头。
2. 案例展示的产品主要采用真空吸附取出，挂布使用 GNS 手动挂布针爪。
3. 案例展示治具使用了 QCA 快换，可实现治具的全自动更换。

Product description:

1. Case product display as one mold with four cavities, no sprue.
2. The products displayed in the case are mainly taken out by vacuum adsorption, and the hanging cloth is hung by GNS manual needle claw.
3. The case shows that the fixture uses QCA quick changer, which can realize the automatic replacement of the fixture



## 汽车 CD 柱取出治具案例

### Automotive CD pillar take out fixture case

产品描述：

1. 案例展示产品为一模四穴，无料头。
2. 案例展示的产品主要采用真空吸附产品。
3. 案例展示治具使用了方形手动快换，以达到快速更换的目的。

Product description:

1. The case shows that the product is one mold with four cavities and no sprue.
2. The products displayed in the case mainly use vacuum adsorption products.
3. The case shows that the fixture uses a square manual quick changer to achieve the purpose of quick changer.

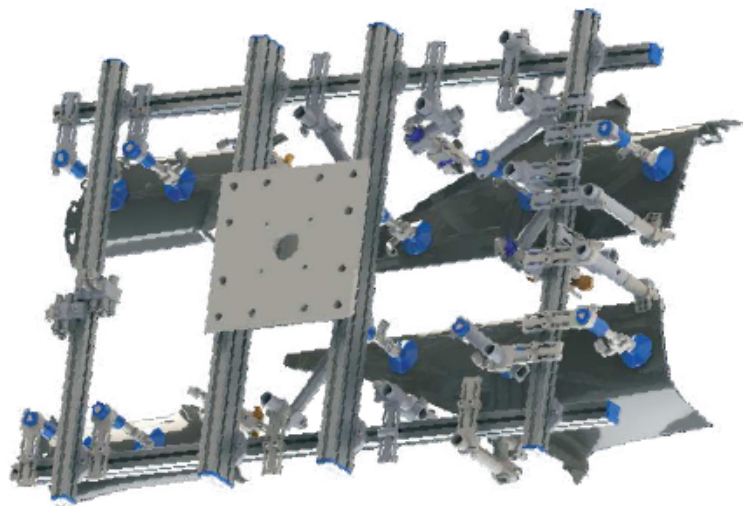

## 汽车中格栅取出治具案例

### Automotive center grill take out fixture case

产品描述：

1. 案例展示产品为一模一穴，无料头。
2. 案例展示的产品主要采用推出吸附为主，气动拨指为辅的取出方式。
3. 案例展示治具使用了方形手动快换，以达到快速更换的目的。

Product description:

1. Case show product for one mold with one cavity, no sprue.
2. The products displayed in the case mainly use the introduction of adsorption, pneumatic finger-assisted extraction method.
3. The case shows that the fixture uses a square manual quick changer to achieve the purpose of quick changer.

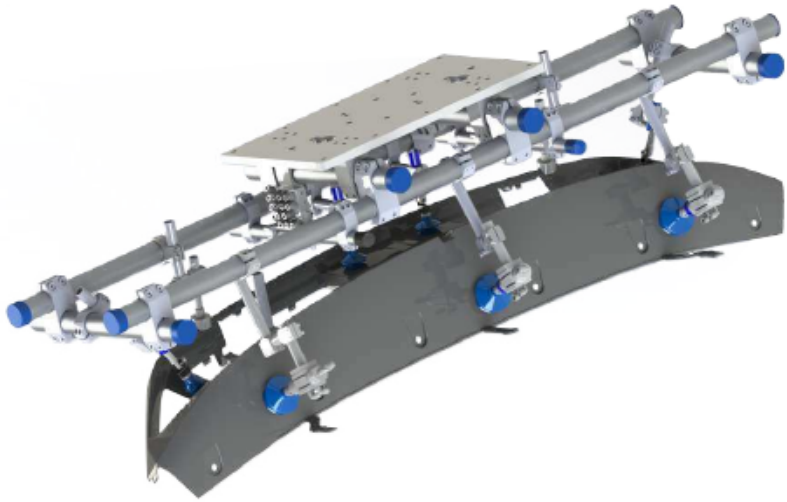

## 汽车除霜格栅取出治具案例

### Automotive defroster grille take out fixture case

产品描述：

1. 案例展示产品为一模一穴，无料头。
2. 案例展示的产品主要采用拨指为主，真空吸附为辅的取出方式。
3. 案例展示治具使用了自动快换，以达到快速更换的目的。

Product description:

1. The case shows that the product is one mold with one cavity, no sprue.
2. The products displayed in the case mainly use the finger gripper, vacuum adsorption as a supplementary way to remove.
3. The case shows that the fixture uses automatic quick changer to achieve the purpose of quick changer.

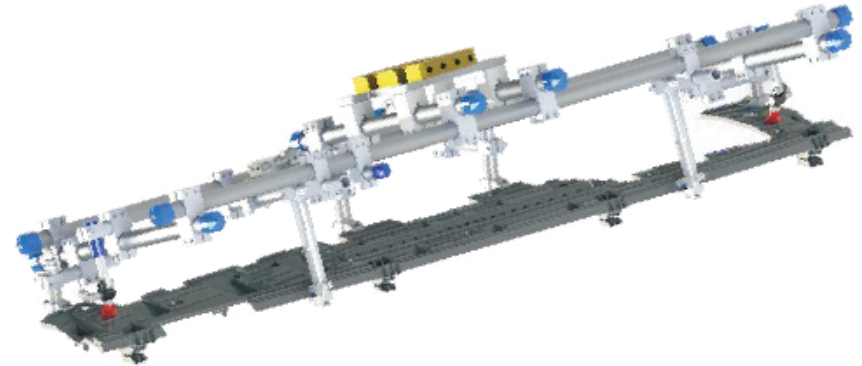

## 汽车前保险杠下格栅取出治具案例

### Automobile front bumper lower grill removal fixture case

#### 产品描述：

1. 案例展示产品为一模两穴，六个料头。
2. 案例展示的产品主要采用拨指为主，真空吸附为辅的取出方式。

#### Product description:

- 1.The case shows that the product is a mold with two cavities and six sprue.
- 2.The products shown in the case are mainly took out by finger-operating, supplemented by vacuum adsorption.

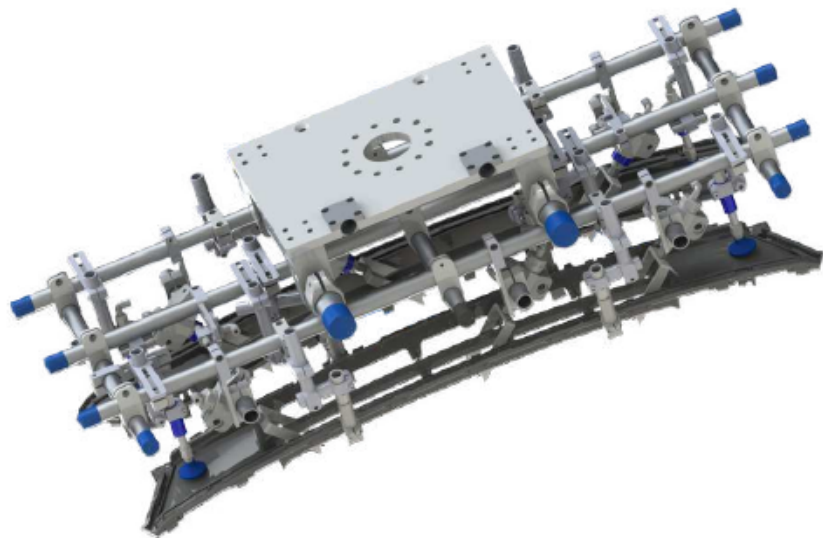

## 汽车前保险杠下格栅取出治具案例

### Automobile front bumper lower grill removal fixture case

#### 产品描述：

1. 案例展示产品为一模一穴，无料头。
2. 案例展示的产品主要采用拨指为主，真空吸附为辅的取出方式。
3. 案例展示治具使用了 QC 手动快换，以达到快速更换的目的。

#### Product description:

- 1.Case show product for one mold with one cavity,no sprue.
- 2.The products displayed in the case mainly use the finger gripper,vacuum adsorption as a supplementary way to remove.
- 3.The case shows that the fixture uses QC manual quick changer to achieve the purpose of quick replacement.



## 汽车前保险杠左右下格栅取出治具案例 Automobile front bumper left and right lower grill removal fixture case

### 产品描述：

1. 案例展示产品为一模两穴,无料头。
2. 案例展示的产品主要采用拨指为主,真空吸附为辅的取出方式。
3. 案例展示治具使用了自动快换,以达到快速更换的目的。

### Product description:

- 1.The case shows that the product is one mold with two cavities and no sprue.
- 2.The products displayed in the case mainly use the finger gripper,vacuum adsorption as a supplementary way to remove.
- 2.The case shows that the fixture uses automatic quick changer to achieve the purpose of quick changer.

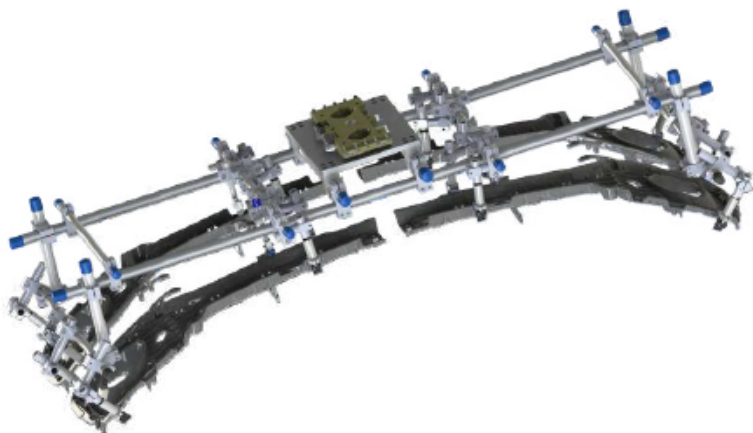

## 汽车双门板取出治具案例 Automotive double door panel removal fixture case

### 产品描述：

1. 案例展示产品为一模两穴,八个料头。
2. 案例展示的产品主要采用真空吸附为主,拨指为辅的取出方式,GRT 系列水口夹取出料头。
3. 案例展示治具使用了 QC 手动快换,以达到快速更换的目的。

### Product description:

- 1.The case shows that the product is one mold with two cavities and eight sprue.
- 2.The products displayed in the case mainly use vacuum adsorption, finger gripper extraction method,GRT series sprue gripper to remove the sprues.
- 3.The case shows that the fixture uses QC manual quick changer to achieve the purpose of quick replacement.

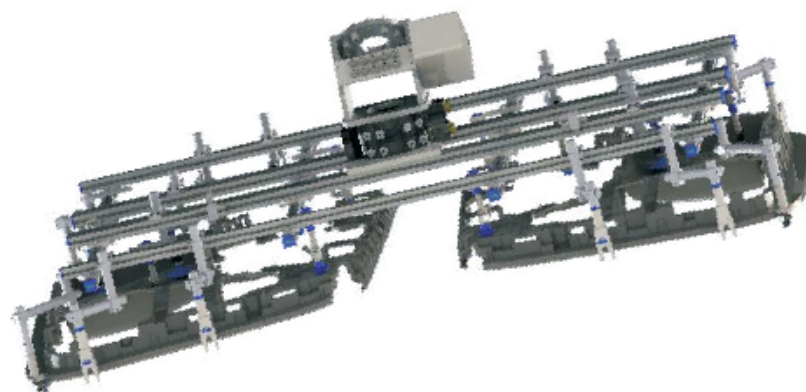

## 前门机械手嵌件治具案例

### Front door manipulator insert fixture case

产品描述：

1. 案例展示产品为一模一穴，七个料头。
2. 案例展示的产品主要采用真空吸附为主，拨指为辅的取出方式，GRT 系列水口夹取出料头。
3. 案例展示治具使用了自动快换，以达到快速更换的目的。

Product description:

1. Case show products for one mold, one cavity, seven sprue.
2. The products displayed in the case mainly use vacuum adsorption, finger gripper extraction method, GRT series sprue gripper to remove the sprue.
3. The case shows that the fixture uses automatic quick changer to achieve the purpose of quick changer.

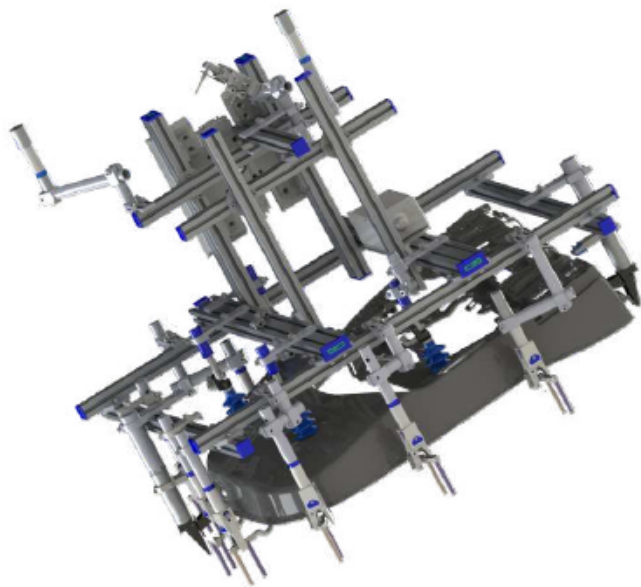

## 保险杠定模取出治具案例

### Bumper mold removal fixture case

产品描述：

1. 案例展示产品为一模一穴，无料头。
2. 案例展示的产品主要采用大力夹为主，真空吸附为辅的取出方式。
3. 案例为定模取件，取件难度高于一般动模取件。

Product description:

1. Case show product for one mold with one cavity, no sprue.
2. The products displayed in the case are mainly extracted by means of strong clamping and vacuum adsorption.
3. The case is a fixed-mold pickup, which is more difficult than moving-mold pickup.

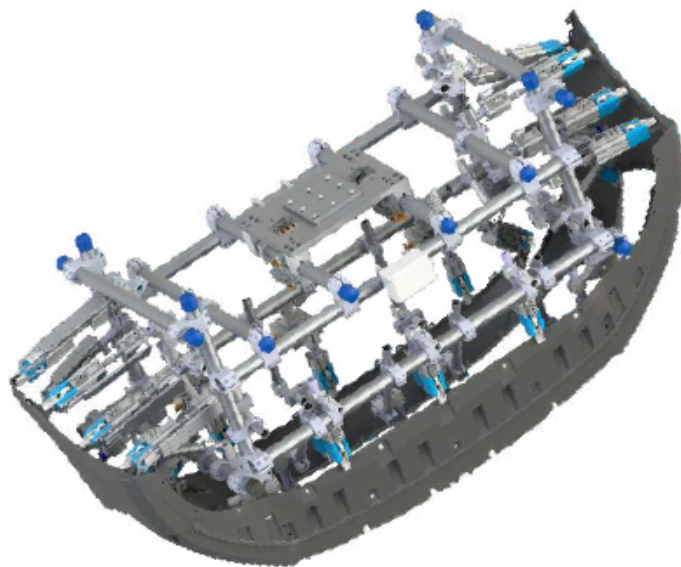

## 汽车后保险杠上本体取出治具案例 Automobile rear bumper body removal fixture case

### 产品描述：

1. 案例展示产品为一模一穴,无料头。
2. 案例展示的产品主要采用推出吸附组合 + 真空吸附组合的取出方式。
3. 案例展示治具使用了 QCA 自动快换,以达到快速更换的目的。

### Product description:

1. Case show product for one mold with one cavity, no sprue.
2. The products displayed in the case mainly adopt the extraction method of pushing adsorption combination & vacuum adsorption combination.
3. The case shows that the fixture uses automatic quick changer to achieve the purpose of QCA quick changer.



## 仪表板本体取出治具案例 Instrument panel body removal fixture case

### 产品描述：

1. 案例展示产品为一模两穴,十个料头。
2. 案例展示的产品主要采用拨指 + 推出吸附的取出方式, GRT 系列水口夹取出料头。
3. 案例展示治具使用了 QCA 自动快换,以达到快速更换的目的。

### Product description:

1. The case shows that the product is one mold with two cavities and ten sprue.
2. The products displayed in the case mainly adopt the extraction method of finger gripper & push adsorption, and the GRT series sprue gripper takes out the sprue.
3. The case shows that the fixture uses automatic quick changer to achieve the purpose of QCA quick changer.

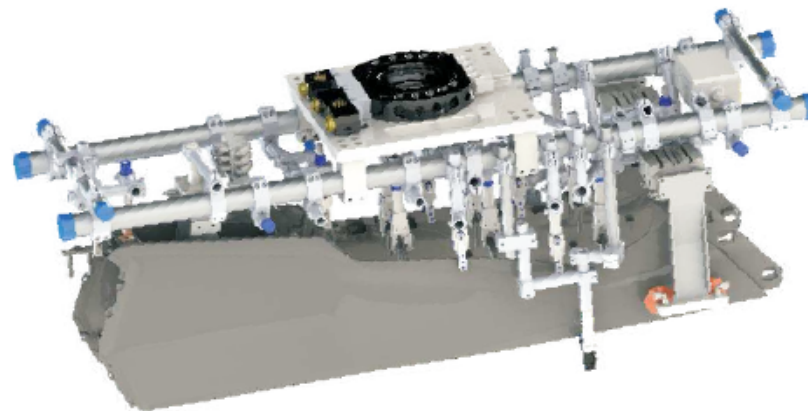

## 汽车仪表板骨架取出治具案例

### Automotive instrument panel skeleton removal fixture case

#### 产品描述：

1. 案例展示产品为一模一穴，一个料头。
2. 案例展示的产品主要采用拨指为主，吸附为辅的取出方式，GRT 系列水口夹取出料头。
3. 案例展示治具使用了 QCA 自动快换，以达到快速更换的目的。

#### Product description:

1. Case show product for one mold with one cavity and one sprue.
2. The products displayed in the case mainly use the way of finger-based, adsorption as a supplement to remove, GRT series sprue gripper to remove the sprue.
3. The case shows that the fixture uses automatic QCA quick changer to achieve the purpose of quick changer.

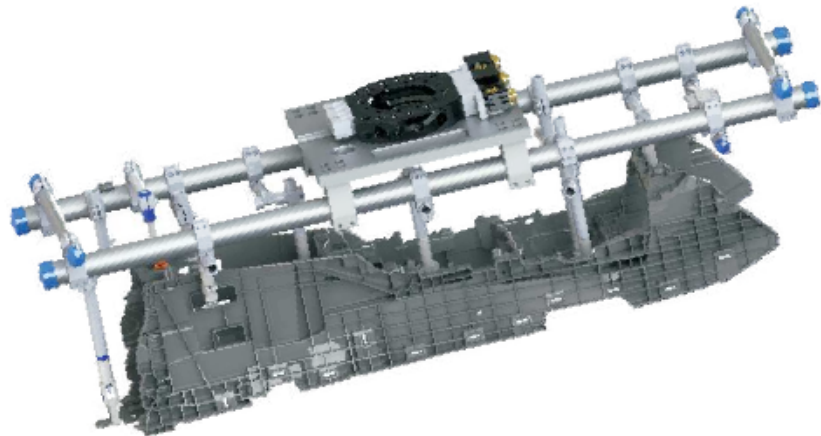

## 仪表板下部骨架取出治具案例

### Instrument panel lower frame removal fixture case

#### 产品描述：

1. 案例展示产品为一模一穴，七个料头。
2. 案例展示的产品主要采用拨指为主，吸附为辅的取出方式，GRT 系列水口夹取出料头。
3. 案例展示治具使用了方形自动快换，以达到快速更换的目的。

#### Product description:

1. Case show products for one mold with one cavity, seven sprue.
2. The products displayed in the case mainly use the way of finger-based, adsorption as a supplement to remove, GRT series gripper to remove the sprue.
3. The case shows that the fixture uses automatic quick changer to achieve the purpose of quick changer.

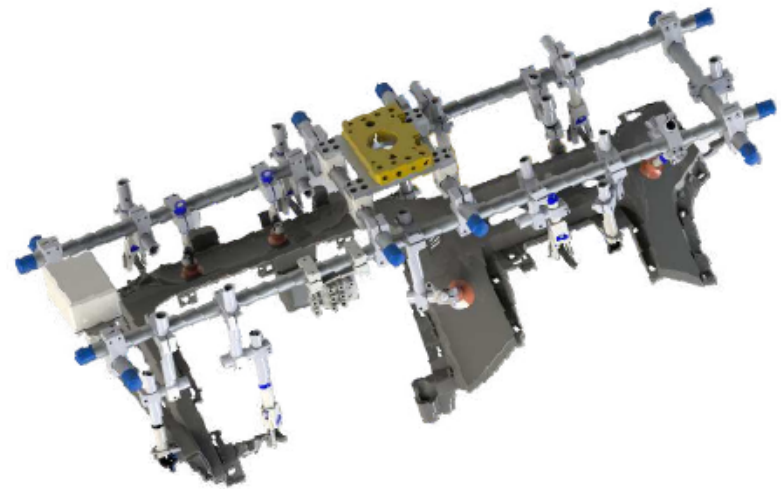

## 汽车轮毂罩取出治具案例 Automotive hubcap removal fixture case

### 产品描述：

1. 案例展示产品为一模一穴，一个料头。
2. 案例展示的产品主要采用真空吸附的取出方式，GRT 系列水口夹取出料头。

### Product description:

- 1.The case shows that the product is one mold with one cavity and one sprue.
- 2.The products displayed in the case are mainly extracted by vacuum adsorption,and the GRT series sprue gripper is used to remove the sprue.

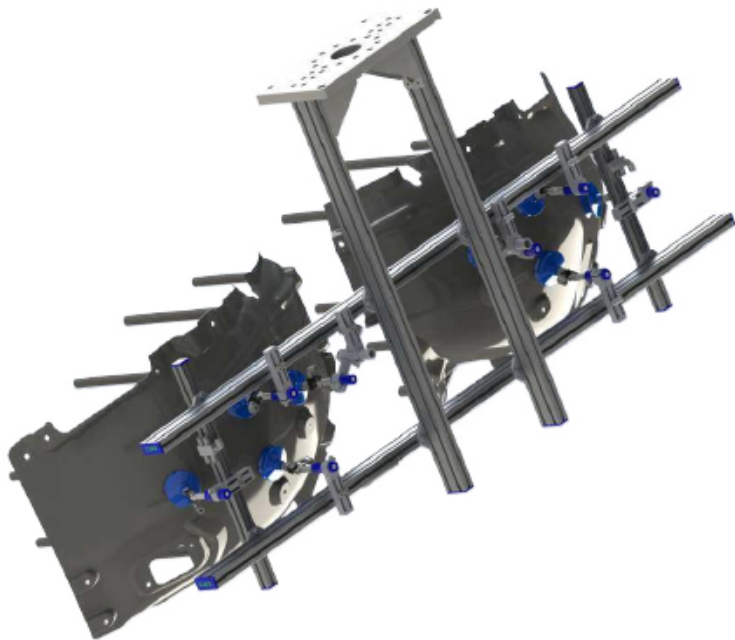

## 汽车轮毂罩取出埋入治具案例 Hubcap removal and flush fixture case

### 产品描述：

1. 案例展示产品为一模一穴，无料头。
2. 案例展示的产品主要采用真空吸附的取出方式，气动针夹 3D 打印仿形埋入毛毡。
3. 案例治具采用了高精度定位器辅助埋入。

### Product description:

- 1.Case show product for one mold with one cavity, no sprue.
- 2.The products displayed in the case are mainly extracted by vacuum adsorption,and pneumatic needle clip & 3D printing copy is embedded in the felt.
- 3.The case fixture is assisted by a high precision positioner.

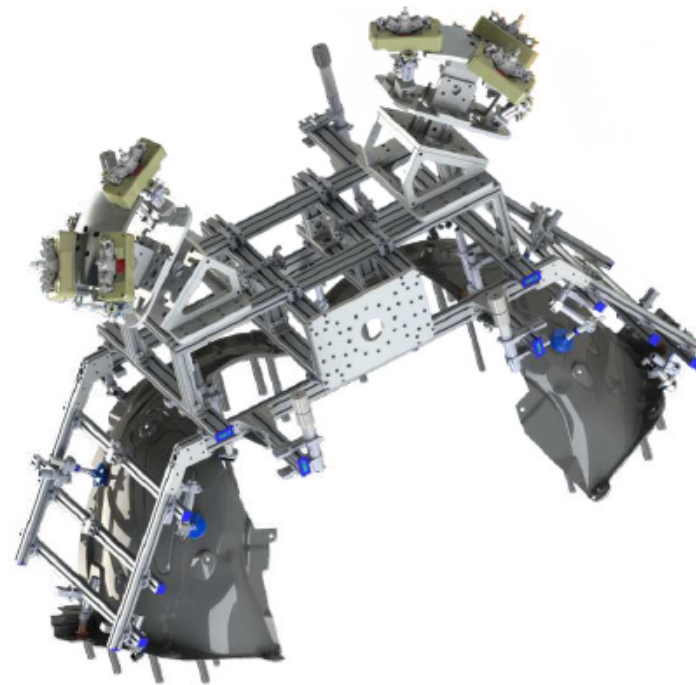



深度定制 IN-DEEP CUSTOMIZED

模块化设计按需深度定制

Modular design is deeply customized on demand



交货期短 SHORT DELIVERY

拥有充足的现货库存

Have sufficient physical inventory industry



品质保障 QUALITY ASSURANCE

高于行业的品质管控体系

Quality control system above the industry



实力厂家 POWERFUL FACTORY

拥有超过 10000 个成功案例

With more than 10,000 successful cases

## 目录内容

Table of Contents

P

型材、钢管  
Profile, SUS Tube

001-007

S

支架模组  
Stents Module

008-070

Q

快换  
Quick Changer

071-214

G

夹具组件  
Grip Module

215-340

N

气动剪刀  
Air Nipper

341-396

V

真空组件  
Vacuum Module

397-441

A

附件  
Accessory Components

442-461

**P-型材、钢管**  
Profile、SUS Tube



**PST-钢管**  
Sus Tube  
页码/Page 001



**PST-碳纤维管**  
Carbon Fiber Tube  
页码/Page 002



**PEP-型材**  
Extruded Profiles  
页码/Page 003-004



**PT-T型螺母**  
T-Nuts  
页码/Page 005

**S-支架模组**  
Stents Module



**SFP-型材固定板**  
Fixing Plate  
页码/Page 010



**SMB-模组固定件**  
Module Fixed Part  
页码/Page 014



**SV-吸盘支架**  
Extruded Profile  
页码/Page 054



**SC-夹腿连接件**  
Clamp Leg Connector  
页码/Page 059



**SEA-弯臂连接件**  
Elbow Arm Connector  
页码/Page 067



**SV-套筒螺母**  
Bush Nut  
页码/Page 070

**Q-快换**  
Quick Changer



**QCA-自动快换**  
Automatic Quick Changer  
页码/Page 078-174



**QC-手动快换**  
Manual Quick Changer  
页码/Page 175-194



**QC-手动快换**  
Manual Quick Changer  
页码/Page 195-200



**QCS-方形手动快换**  
Square Manual Quick Changer  
页码/Page 201-203



**QCL-L形手动快换**  
L-Shape Manual Quick Changer  
页码/Page 204-206



**QCA-方形自动快换**  
Square Automatic Quick Changer  
页码/Page 208



**QCA-20自动快换**  
Quick Changer  
页码/Page 209



**QCA-130自动快换**  
Quick Changer  
页码/Page 212



**OFU-补偿单元**  
Compensation Unit  
页码/Page 208

**G-夹具组件**  
Grip Module



**GMH-气缸夹**  
Cylinder Gripper  
页码/Page 220-221



**GMHZL2-加长平行夹**  
Lengthen Parallel Gripper  
页码/Page 222-225



**GR-水口夹**  
Sprue Gripper  
页码/Page 227-284



**GBD-膨胀器**  
Expansion Gripper  
页码/Page 304-306



**GS-缓冲支架**  
Buffer Support  
页码/Page 308



**GMP-模具定位器**  
Mould Positioner  
页码/Page 310-311



**GN-气动针夹**  
Pneumatic Needle Gripper  
页码/Page 312-317



**GF-气动拨指**  
Pneumatic Finger Gripper  
页码/Page 318-330



**GO-单动拨指**  
One Finger Angular Pneumatic Grippers  
页码/Page 331



**GFT-姿势组配件**  
Pneumatic Tilt Units  
页码/Page 333-337

**N-气动剪刀**  
Air Nipper



**N-剪刀本体**  
Air Nipper Body  
页码/Page 346-350



**N-剪刀刀头**  
Air Nipper Blade  
页码/Page 351-358, 383-387



**GT-推入式气剪**  
Thrust Cut Nippers  
页码/Page 364-369



**气动剪刀本体**  
Square Air Nipper  
页码/Page 389-394

**V-真空组件**  
Vacuum Module



**FGA-吸盘**  
Vacuum Cup  
页码/Page 398-404



**VSH-吸盘**  
Vacuum Cup  
页码/Page 405-407



**SAF-吸盘**  
Vacuum Cup  
页码/Page 408-409



**VM-吸盘金具转接头**  
Vacuum Cup Connector  
页码/Page 410-418



**VF-金具缓冲杆**  
Stem Suction Buffer Body  
页码/Page 420-429



**Compact-真空模组**  
Vacuum Module  
页码/Page 432-441

**A-附件**  
Accessory Components



**ASC-信号盒**  
Signal Box  
页码/Page 442



**AJB-分线盒**  
Junction Box  
页码/Page 444-447



**ARJ-微型减压阀**  
Miniature Regulator  
页码/Page 448



**KQ2-气管接头**  
Hose Fitting  
页码/Page 453



**AH-气管**  
Hose  
页码/Page 461

## 不锈钢管

Sus Tube

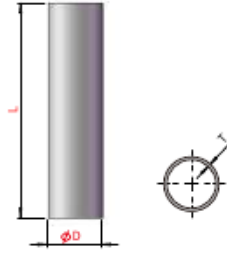

钢管端盖  
Tube plugs



货号(PN)	型号(Model)	D(mm)	L(mm)	T(mm)	重量(Weight)	端盖(PN)	端盖(Model)
4.Y00040	PST8-1500	Ø8	1500	0.6	215g	1.Y03375(红色Red)	P08RD
4.Y00021	PST12-1500	Ø12	1500	0.6	339g	1.Y03636(灰色Grey) 1.Y03638(蓝色Blue) 1.Y03640(黑色Black)	P12GY P12BU P12BK
4.Y00022	PST20-1500	Ø20	1500	0.8	560g	1.Y03637(灰色Grey) 1.Y03639(蓝色Blue) 1.Y03641(黑色Black)	P20GY P20BU P20BK

## 铝管

Aluminium Tube

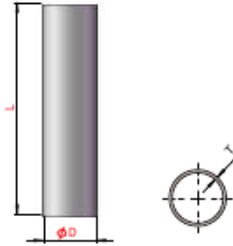

钢管端盖  
Tube plugs



货号(PN)	型号(Model)	D(mm)	L(mm)	T(mm)	重量(Weight)	端盖(PN)	端盖(Model)
4.Y00468	PAT20-1000	Ø20	1000	2.0	308g	1.Y03637(灰色Grey)	P20GY
4.Y10972	PAT20-2000	Ø20	2000	2.0	616g	1.Y03639(蓝色Blue) 1.Y03641(黑色Black)	P20BU P20BK
4.Y10950	PAT25-1000	Ø25	1000	2.5	467g		
4.Y10974	PAT25-2000	Ø25	2000	2.5	934g	1.Y10988(黑色Black)	P25BK
4.Y00469	PAT30-1000	Ø30	1000	2.5	558g		
4.Y10973	PAT30-2000	Ø30	2000	2.5	1116g	1.Y20001(黑色Black)	P30BK
4.Y00538	PAT40-1000	Ø40	1000	2.5	799g		
4.Y10975	PAT40-2000	Ø40	2000	2.5	1558g	1.Y10987(黑色Black)	P40BK

Profile, SUS Tube  
型材、钢管

Stents Module  
支架模组

Quick Changer  
快换

Grip Module  
夹具组件

Air Nipper  
气动剪刀

Vacuum Module  
真空组件

Accessory Components  
附件

## 碳纤维管

Carbon fiber Tube

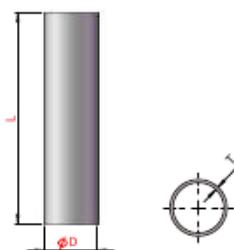

钢管端盖

Tube plugs



货号(PN)	型号(Model)	D(mm)	L(mm)	T(mm)	重量(Weight)	端盖(PN)	端盖(Model)
4.Y10960	PCT8-1000	Ø8	1000	1.0	31g	1.Y03375(红色Red)	P08RD
4.Y10961	PCT8-2000	Ø8	2000	1.0	62g		
4.Y10962	PCT12-1000	Ø12	1000	1.0	59g	1.Y03636(灰色Grey)	P12GY
4.Y10963	PCT12-2000	Ø12	2000	1.0	118g	1.Y03638(蓝色Blue) 1.Y03640(黑色Black)	P12BU P12BK
4.Y10964	PCT20-1000	Ø20	1000	1.5	103g	1.Y03637(灰色Grey)	P20GY
4.Y10965	PCT20-2000	Ø20	2000	1.5	206g	1.Y03639(蓝色Blue) 1.Y03641(黑色Black)	P20BU P20BK
4.Y10966	PCT25-1000	Ø25	1000	2.5	169g		
4.Y10967	PCT25-2000	Ø25	2000	2.5	339g	1.Y10988(黑色Black)	P25BK
4.Y10968	PCT30-1000	Ø30	1000	2.5	236g		
4.Y10969	PCT30-2000	Ø30	2000	2.5	472g	1.Y20001(黑色Black)	P30BK
4.Y10970	PCT40-1000	Ø40	1000	2.5	431g		
4.Y10971	PCT40-2000	Ø40	2000	2.5	861g	1.Y10987(黑色Black)	P40BK

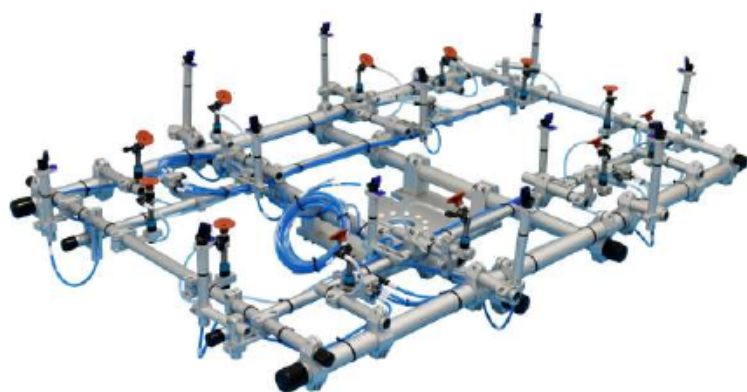

Profile- SUSTube  
型材、钢管

Stents Module  
支架模组

Quick Changer  
快换

Grip Module  
夹具组件

Air Nipper  
气动剪刀

Vacuum Module  
真空组件

Accessory Components  
附件

# 型材

## Extruded Profiles

Profile、SUS Tube  
型材、钢管

Stentis Module  
支架模组

Quick Changer  
快换

Grip Module  
夹具组件

Air Nipper  
气动剪刀

Vacuum Module  
真空组件

Accessory Components  
附件

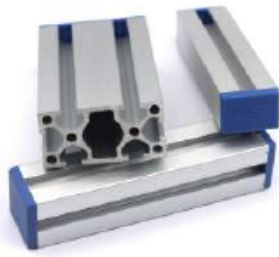

### 型材端盖 Plugs for profile

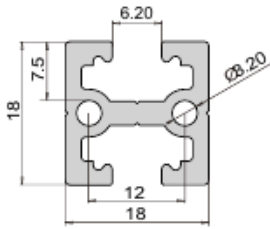

PEP1818

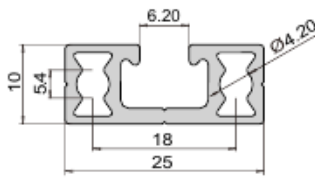

PEP2510

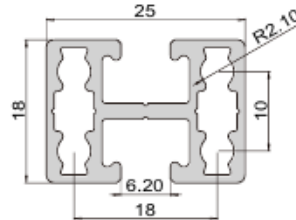

PEP2518

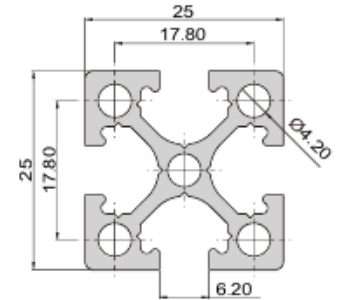

PEP2525

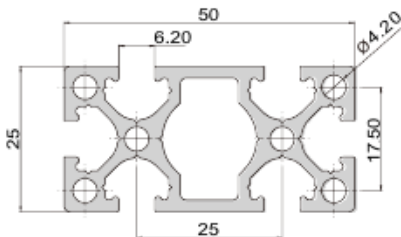

PEP5025

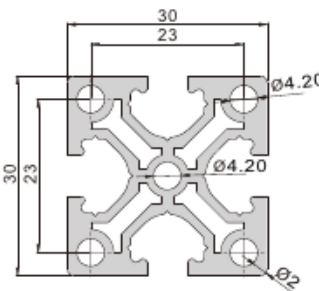

PEP3030

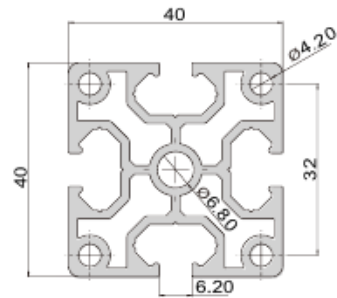

PEP4040

货号(PN)	型号(Model)	长度(Length)	重量(Weight)	端盖货号(Plugs PN)	端盖型号(Plugs Model)
4.Y00075	PEP1818-1000	1.0m	425g	4.Y00517	P1818
4.Y00076	PEP2510-1000	1.0m	310g	4.Y00518	P2510
4.Y00455	PEP2518-1000	1.0m	400g	4.Y00069	P2518
4.Y00050	PEP2525-1000	1.0m	610g	4.Y00070	P2525
* 4.Y00051	PEP2525-2000	2.0m	1220g		
4.Y00056	PEP5025-1000	1.0m	1040g	4.Y00071	P5025
* 4.Y00057	PEP5025-2000	2.0m	2080g		
4.Y00052	PEP4040-1000	1.0m	1300g	4.Y00072	P4040
* 4.Y00053	PEP4040-2000	2.0m	2600g		
4.Y00540	PEP3030-1000	1.0m	650g	4.Y00542	P3030
* 4.Y00541	PEP3030-2000	2.0m	1300g		

\* 选件 Optional

# 型材

## Extruded Profiles



钢管端盖  
Tube plugs

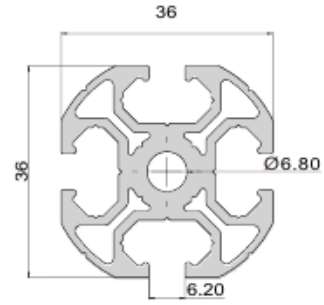

PEP-3636



货号(PN)	型号(Model)	长度(Length)	重量(Weight)	端盖货号(Plugs PN)	端盖型号(Plugs Model)
4.Y00054	PEP3636-1000	1.0m	1168g		
4.Y00484	PEP3636-1500	1.5m	1752g	4.Y00073	P3636
* 4.Y00055	PEP3636-2000	2.0m	2336g		

\* 选件 Optional

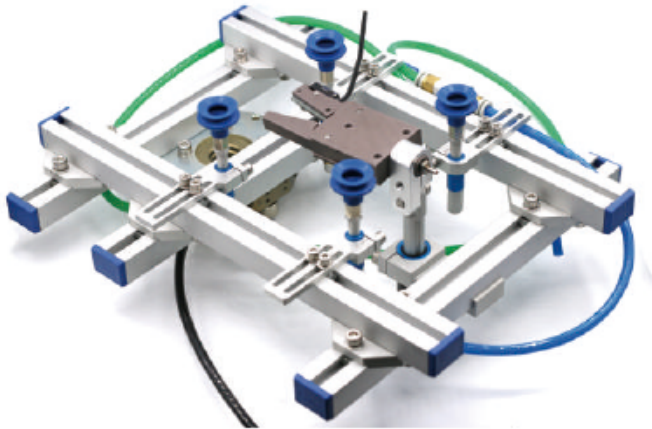

Profile- SUS Tube  
型材、钢管

Stents Module  
支架模组

Quick Changer  
快换

Grip Module  
夹具组件

Air Nipper  
气动剪刀

Vacuum Module  
真空组件

Accessory Components  
附件

## T型螺母

### T-Nuts

Profile, SUS Tube  
型材、钢管

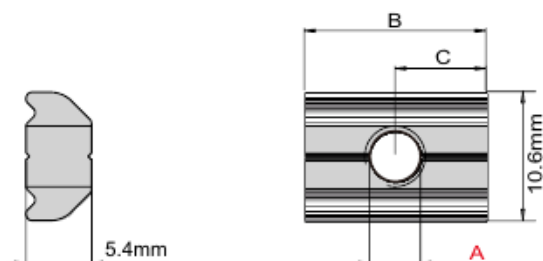

Stents Module  
支架模组

货号(PN)	型号(Model)	A(mm)	B(mm)	C(mm)	重量(Weight)
7.Y00651	PTN-M4	M4	15	7.5	5g
7.Y00425	PTN-M5	M5	15	7.5	5g
7.Y00652	PTN-M6	M6	15	7.5	5g

Quick Changer  
快换

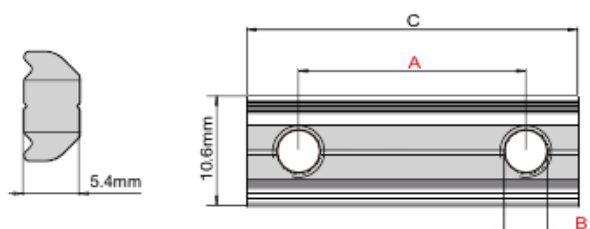
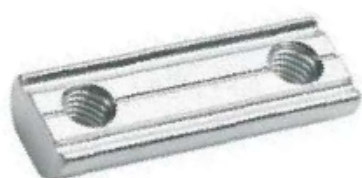

Grip Module  
夹具组件

货号(PN)	型号(Model)	A(mm)	B(mm)	C(mm)	重量(Weight)
7.Y00653	PTN-M4P8	8	M4	16	5g
7.Y00654	PTN-M5P10	10	M5	20	7g
7.Y00655	PTN-M5P15	15	M5	25	9g
7.Y00656	PTN-M5P17	17	M5	25	9g
7.Y00657	PTN-M5P22	22	M5	32	11g
7.Y00658	PTN-M5P25	25	M5	35	13g
7.Y00659	PTN-M5P28	28	M5	38	14g
7.Y00660	PTN-M5P30	30	M5	40	15g
7.Y00661	PTN-M5P35	35	M5	45	16g
7.Y00662	PTN-M5P40	40	M5	50	18g
7.Y00663	PTN-M5P50	50	M5	60	22g
7.Y00664	PTN-M5P60	60	M5	70	26g
7.Y00665	PTN-M5P90	90	M5	100	38g

Air Nipper  
气动剪刀

Vacuum Module  
真空组件

## 附加螺母

### Last-Minute Nut

Accessory Components  
附件

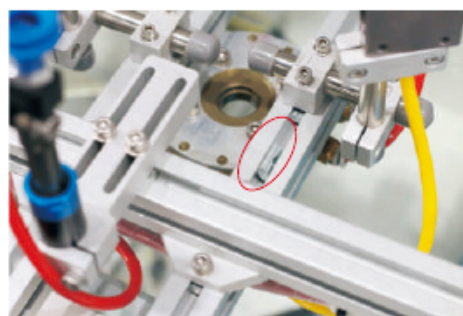
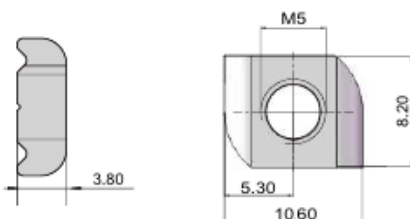

货号(PN)	型号(Model)	重量(Weight)
7.Y00805	PTN-M5R	2g

当已装配好的治具需要增加一些配件时可以使用。

To be used when you need to add something to an already assembled EOAT.

# 不锈钢螺丝

## Sus Screws

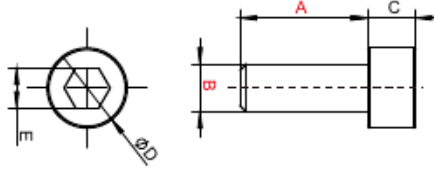

货号(PN)	型号(Model)	A(mm)	B(mm)	C(mm)	D(mm)	E(mm)	重量(Weight)
1.Y03908	PTC-M4L10	10					1.6g
1.Y03848	PTC-M4L12	12					1.8g
1.Y02752	PTC-M4L14	14					1.9g
1.Y04073	PTC-M4L16	16					2.0g
1.Y05846	PTC-M4L18	18	M4	4	6.8	3.2	2.1g
1.Y04000	PTC-M4L20	20					2.2g
1.Y06307	PTC-M4L22	22					2.5g
1.Y05319	PTC-M4L25	25					2.7g
1.Y04294	PTC-M5L10	10					2.9g
1.Y03850	PTC-M5L12	12					3.1g
1.Y04528	PTC-M5L14	14					3.3g
1.Y03849	PTC-M5L16	16					3.6g
1.Y05925	PTC-M5L18	18					3.8g
1.Y03909	PTC-M5L20	20					4.0g
1.Y06257	PTC-M5L22	22	M5	5	8.3	4.1	4.3g
1.Y03851	PTC-M5L25	25					4.7g
1.Y04469	PTC-M5L30	30					5.3g
1.Y04580	PTC-M5L35	35					5.9g
1.Y04898	PTC-M5L40	40					6.5g
1.Y04968	PTC-M5L50	50					7.6g
1.Y05391	PTC-M5L60	60					10.0g
1.Y04288	PTC-M6L10	10					4.0g
1.Y03910	PTC-M6L12	12					4.6g
1.Y04153	PTC-M6L14	14					5.2g
1.Y02753	PTC-M6L16	16					5.5g
1.Y07729	PTC-M6L18	18	M6	6	10	5.3	5.7g
1.Y04076	PTC-M6L20	20					6.1g
1.Y06227	PTC-M6L25	25					6.9g
1.Y04001	PTC-M6L30	30					7.7g
1.Y03911	PTC-M6L35	35					8.6g

Profile- SUS Tube  
型材、钢管

Stents Module  
支架模组

Quick Changer  
快换

Grip Module  
夹具组件

Air Nipper  
气动剪刀

Vacuum Module  
真空组件

Accessory Components  
附件

## 双齿平垫

### Single Hole Shim

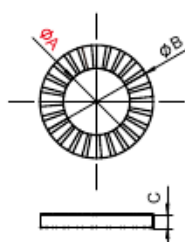

货号(PN)	型号(Model)	A(mm)	B(mm)	C(mm)	重量(Weight)
1.Y03853	PTS-M4	4.5	7	0.45	0.07g
1.Y03852	PTS-M5	5.5	9	0.55	0.17g
1.Y03854	PTS-M6	6.5	10	0.65	0.20g

## 双孔平垫

### Double Holes Shim

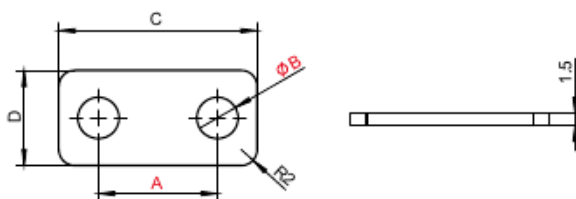

货号(PN)	型号(Model)	A(mm)	B(mm)	C(mm)	D(mm)	重量(Weight)
4.Y00522	PTD-M4P8	8	4.5	16	12	1.8g
4.Y00523	PTD-M5P10	10	5.5	20	12	2.2g
4.Y00524	PTD-M5P15	15	5.5	25	12	2.5g
4.Y00525	PTD-M5P17	17	5.5	25	12	3.0g
4.Y00526	PTD-M5P22	22	5.5	32	12	3.3g
4.Y00527	PTD-M5P25	25	5.5	35	12	3.5g



# 直型型材连接板

## Straight Fixing Plate

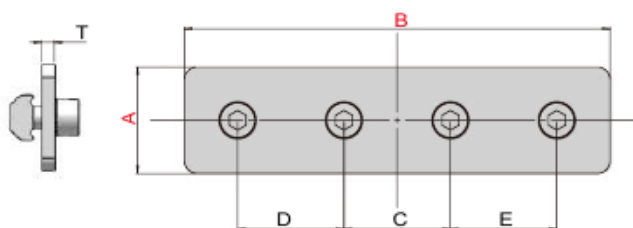

(螺钉套件选配) (Kit With Screws Option)

货号(PN)	7.Y00641	7.Y00642	7.Y00643
型号(Model)	SFP-S2550	SFP-S25100	SFP-S40160
A(mm)	25	25	40
B(mm)	50	100	160
C(mm)	25	25	40
D(mm)	-	25	40
E(mm)	-	25	40
T(mm)	3	3	3
PEP2510	√	√	-
PEP2518	√	√	-
PEP2525	√	√	-
PEP5025	√	√	-
PEP4040	-	-	√
<b>螺钉选配件 Accessoirier selection</b>			
螺丝(Screws)	PTC-M5L12*2	PTC-M5L12*4	PTC-M5L12*4
双齿平垫(Single hole shim)	PTS-M5*2	PTS-M5*4	PTS-M5*4
T型螺母(T-Nuts)	PTN-M5*2	PTN-M5P25*2	PTN-M5P40*2
总重量(Weight)	45g	95g	195g

注: 如需螺钉套件货号 and 型号加T 如: 型号SFP-S2550T 货号7.Y00641-T

Note: If screw kits needed, add T to the part number and model number. eg: Model SFP-S2550T Part number 7.Y00641-T.



Profile- SUS Tube  
型材、钢管

Stents Module  
支架模组

Quick Changer  
快换

Grip Module  
夹具组件

Air Nipper  
气动剪刀

Vacuum Module  
真空组件

Accessory Components  
附件

# L型型材连接板

## L-shaped Fixing Plate

Profile, SUS Tube  
型材、钢管

Stentis Module  
支架模组

Quick Changer  
快换

Grip Module  
夹具组件

Air Nipper  
气动剪刀

Vacuum Module  
真空组件

Accessory Components  
附件



(螺钉套件选配) (Kit With Screws Option)

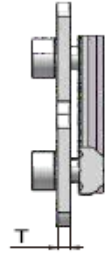
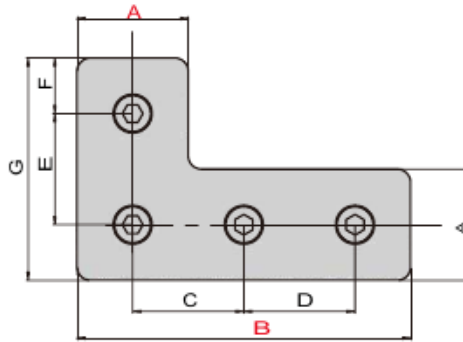

货号(PN)	7.Y00647	7.Y00648	7.Y00649
型号(Model)	SFP-L2550	SFP-L2575	SFP-L40120
A(mm)	25	25	40
B(mm)	50	75	120
C(mm)	25	25	40
D(mm)	-	25	40
E(mm)	25	25	40
F(mm)	12.5	12.5	20
G(mm)	50	50	80
T(mm)	3	3	3
PEP2510	√	√	-
PEP2518	√	√	-
PEP2525	√	√	-
PEP5025	√	√	-
PEP4040	-	-	√
螺钉选配件 Accessorier selection			
螺丝(Screws)	PTC-M5L12*3	PTC-M5L12*4	PTC-M5L12*4
双齿平垫(Single hole shim)	PTS-M5*3	PTS-M5*4	PTS-M5*4
T型螺母(T-Nuts)	PTN-M5*1	PTN-M5P25*2	PTN-M5P40*2
	PTN-M5P25*1		
总重量(Weight)	70g	95g	200g

注: 如需螺钉套件货号 and 型号加 T 如: 型号 SFP-L2550 T 货号 7.Y00647-T

Note: If screw kits needed, add T to the part number and model number. eg: Model SFP-L2550 T Part number 7.Y00647-T.



# T型固定板

## T-shaped Fixing Plate



(螺钉套件选配) (Kit With Screws Option)

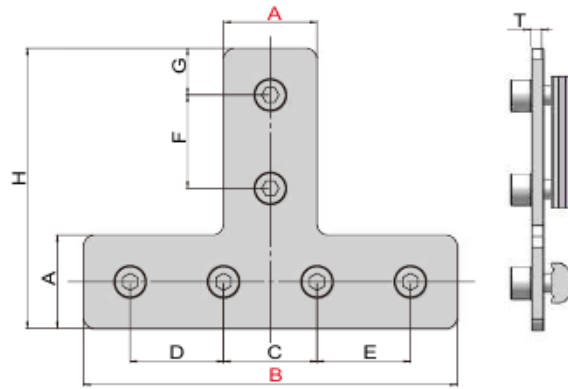

货号(PN)	7.Y00644	7.Y00645	7.Y00646
型号(Model)	SFP-T2550	SFP-T25100	SFP-T40120
A(mm)	25	25	40
B(mm)	50	100	120
C(mm)	25	25	90
D(mm)	-	25	-
E(mm)	-	25	-
F(mm)	25	25	40
G(mm)	12.5	12.5	15
H(mm)	75	75	110
T(mm)	3	3	3
PEP2510	√	√	-
PEP2518	√	√	-
PEP2525	√	√	-
PEP5025	√	√	-
PEP4040	-	-	√
螺钉选配件 Accessorier selection			
螺丝(Screws)	PTC-M5L12*4	PTC-M5L12*6	PTC-M5L12*4
双齿平垫(Single hole shim)	PTS-M5*4	PTS-M5*6	PTS-M5*4
T型螺母(T-Nuts)	PTN-M5P25*2	PTN-M5P25*3	PTN-M5P40*1 PTN-M5P90*1
总重量(Weight)	95g	145g	250g

注: 如需螺钉套件货号 and 型号加 T 如: 型号 SFP-T2550T 货号 7.Y00644-T

Note: If screw kits needed, add T to the part number and model number. eg: Model SFP-T2550T Part number 7.Y00644-T.

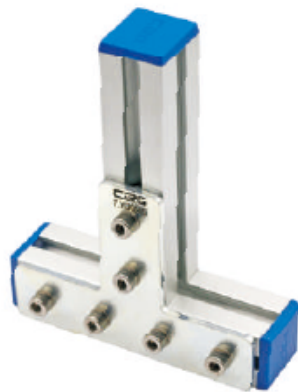

Profile- SUS Tube  
型材、钢管

Stents Module  
支架模组

Quick Changer  
快换

Grip Module  
夹具组件

Air Nipper  
气动剪刀

Vacuum Module  
真空组件

Accessory Components  
附件

# 可调节角度型材连接板

## Fixing Plate With Adjustable Angle

Profile, SUS Tube  
型材、钢管

Stentis Module  
支架模组

Quick Changer  
快换

Grip Module  
夹具组件

Air Nipper  
气动剪刀

Vacuum Module  
真空组件

Accessory Components  
附件



(螺钉套件选配) (Kit With Screws Option)

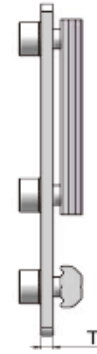
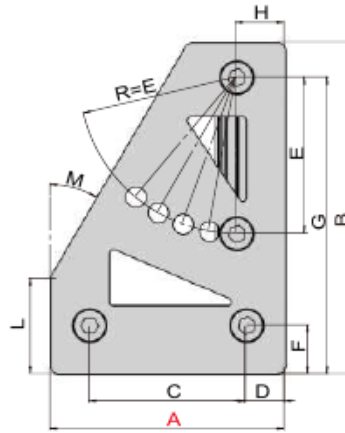

货号(PN)	7.Y00637	7.Y00638	7.Y00639
型号(Model)	SFP-A60	SFP-A90	SFP-A70
A(mm)	60	90	70
B(mm)	85	95	100
C(mm)	40	60	50
D(mm)	10	15	10
E(mm)	40	50	40
F(mm)	12.5	12.5	20
G(mm)	76	86	90
H(mm)	12.5	12.5	20
L(mm)	25	25	40
M(mm)	30°	30°	27°
T(mm)	3	3	3
PEP2510	√	√	-
PEP2518	√	√	-
PEP2525	√	√	-
PEP5025	√	√	-
PEP4040	-	-	√

### 螺钉选配件 Accessorier selection

螺丝(Screws)	PTC-M5L12*4	PTC-M5L12*5	PTC-M5L12*4
双齿平垫(Single hole shim)	PTS-M5*4	PTS-M5*5	PTS-M5*4
T型螺母(T-Nuts)	PTN-M5P40*2	PTN-M5P50*1 PTN-M5P60*1 PTN-M5*1	PTN-M5P40*1 PTN-M5P50*1
总重量(Weight)	130g	215g	175g

注: 如需螺钉套件货号 and 型号加 T 如: 型号 SFP-A60T 货号 7.Y00637-T

Note: If screw kits needed, add T to the part number and model number. eg: Model SFP-A60T Part number 7.Y00637-T.



## 可调节角度型材连接板

Fixing Plate With Adjustable Angle



(螺钉套件选配) (Kit With Screws Option)

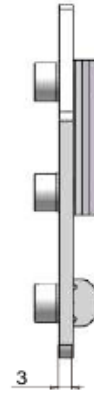
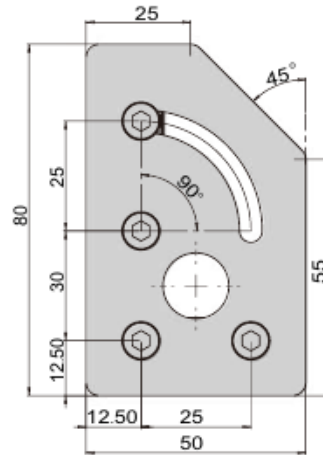

货号(PN)	7.Y00640
型号(Model)	SFP-A50
厚度(T)	3mm
螺钉选配件 Accessorier selection	
螺丝(Screws)	PTC-M5L12*4
双齿平垫(Single hole shim)	PTS-M5*4
T型螺母(T-Nuts)	PTN-M5P25*2
总重量(Weight)	115g

注: 如需螺钉套件货号 and 型号加 T 如: 型号 SFP-A60T 货号 7.Y00637-T

Note: If screw kits needed, add T to the part number and model number. eg: Model SFP-A60T Part number 7.Y00637-T.

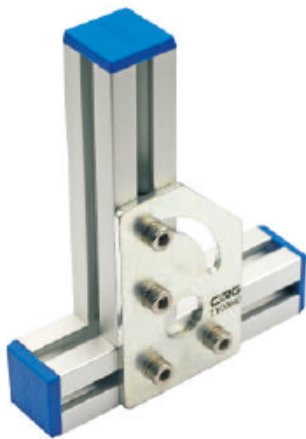

Profile- SUS Tube  
型材、钢管

Stents Module  
支架模组

Quick Changer  
快换

Grip Module  
夹具组件

Air Nipper  
气动剪刀

Vacuum Module  
真空组件

Accessory Components  
附件

## 45°固定板 45° Fixing Plate

Profile、SUS Tube  
型材、钢管

Stents Module  
支架模组

Quick Changer  
快换

Grip Module  
夹具组件

Air Nipper  
气动剪刀

Vacuum Module  
真空组件

Accessory Components  
附件



(螺钉套件选配) (Kit With Screws Option)

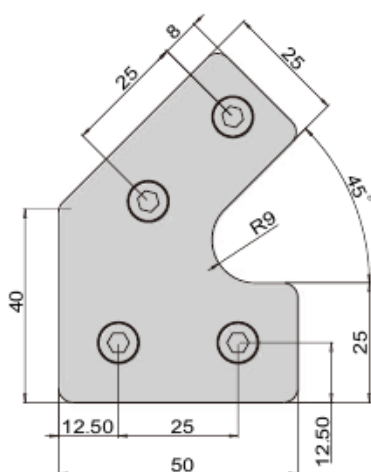

货号(PN)	7.Y00636
型号(Model)	SFP-50
厚度(T)	3mm
螺钉选配件 Accessorier selection	
螺丝(Screws)	PTC-M5L12*4
双齿平垫(Single hole shim)	PTS-M5*4
T型螺母(T-Nuts)	PTN-M5P25*2
总重量(Weight)	100g

注: 如需螺钉套件货号 and 型号加T 如: 型号SFP-50T 货号7.Y00636-T

Note: If screw kits needed, add T to the part number and model number. eg: Model SFP-50T Part number 7.Y00636-T.



# 十字型材连接件

## Cross Mounting Bracket For Profiles



(螺钉套件选配) (Kit With Screws Option)

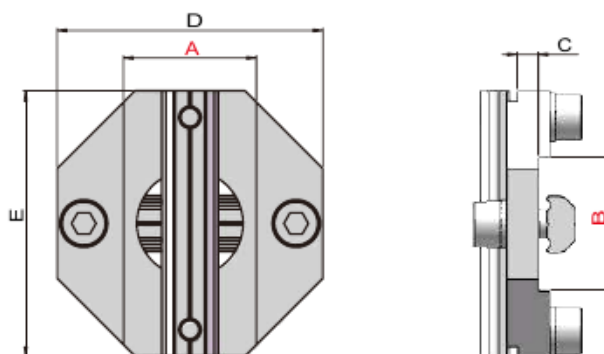

货号(PN)	型号(Model)	A	B	C	D	E	PEP1818	PEP2510	PEP2518	PEP2525	PEP5025	PEP4040	PEP3030
7.Y00290	SMBA-1818	18	18	2	38	38	√						
7.Y00291	SMBA-1825	18	25	4	38	45	√		√	√	√		
7.Y00245	SMBA-2020	20	20	4	50	50			√	√	√		
7.Y00194	SMBA-2525	25	25	4	50	50		√	√	√	√		
7.Y00193	SMBA-3030	30	30	4	50	50							√
7.Y00011	SMBA-5050	50	50	4	70	70					√		
7.Y00292	SMBA-2550	25	50	4	70	70		√	√	√	√		
7.Y00246	SMBA-4040	40	40	4	60	60						√	
7.Y00355	SMBA-8080	80	80	4	100	100							
7.Y00293	SMBA-4080	40	80	4	60	100						√	
7.Y00294	SMBA-2580	25	80	4	45	100			√	√	√	√	
7.Y00356	SMBA-2540	25	40	4	45	60		√	√	√	√	√	
7.Y00690	SMBA-3025	30	25	4	50	50		√					

### 螺钉选配件 Accessorier selection

型号(Model)	螺丝(Screws)	双齿平垫(Single hole shim)	T型螺母(T-Nuts)	总重量(Weight)
SMBA-1818	PTC-M5L12*4	PTS-M5*4	PTN-M5P28*2	46g
SMBA-1825	PTC-M5L14*4	PTS-M5*4	PTN-M5P28*1,PTN-M5P35*1	60g
SMBA-2020	PTC-M5L14*4	PTS-M5*4	PTN-M5P40*2	75g
SMBA-2525	PTC-M5L14*4	PTS-M5*4	PTN-M5P40*2	75g
SMBA-3030	PTC-M5L14*4	PTS-M5*4	PTN-M5P40*2	74g
SMBA-5050	PTC-M5L14*8	PTS-M5*8	PTN-M5P60*4	170g
SMBA-2550	PTC-M5L14*6	PTS-M5*6	PTN-M5P60*3	155g
SMBA-4040	PTC-M5L16*4	PTS-M5*4	PTN-M5P50*2	85g
SMBA-8080	PTC-M5L16*8	PTS-M5*8	PTN-M5P90*4	255g
SMBA-4080	PTC-M5L16*6	PTS-M5*6	PTN-M5P50*2,PTN-M5P90*1	175g
SMBA-2580	PTC-M5L14*2 16*4	PTS-M5*6	PTN-M5P35*2,PTN-M5P90*1	140g
SMBA-2540	PTC-M5L14*2 16*2	PTS-M5*4	PTN-M5P35*1,PTN-M5P50*1	48g
SMBA-3025	PTC-M5L16*4	PTS-M5*4	PTN-M5P40*2	47g

注: 如需螺钉套件货号 and 型号加 T 如: 型号 SMBA-1818 T 货号 7.Y00290-T

Note: If screw kits needed, add T to the part number and model number. eg: Model SMBA-1818 T Part number 7.Y00290-T



Profile- SUS Tube  
型材、钢管

Stents Module  
支架模组

Quick Changer  
快换

Grip Module  
夹具组件

Air Nipper  
气动剪刀

Vacuum Module  
真空组件

Accessory Components  
附件

# 方形交叉型材连接件

## Cross (Square) Joint Connector

Profile, SUS Tube  
型材、钢管

Stents Module  
支架模组

Quick Changer  
快换

Grip Module  
夹具组件

Air Ripper  
气动剪刀

Vacuum Module  
真空组件

Accessory Components  
附件



(螺钉套件选配) (Kit With Screws Option)

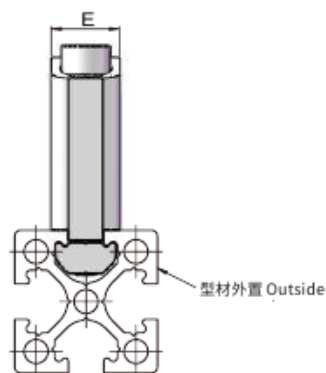
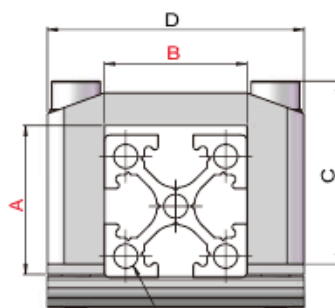

货号(PN)	7.Y00295	7.Y00817	7.Y00012	7.Y00339	7.Y00340	7.Y00163
型号(Model)	SMBB-1818	SMBB-1825	SMBB-2525	SMBB-5025	SMBB-2550	SMBB-3030
A(mm)	18	18	25	50	25	30
B(mm)	18	25	25	25	50	30
C(mm)	25	25	32	57	33	38
D(mm)	38	45	45	45	70	50
E(mm)	12	12	12	12	12	12
型材内置 Inside	PEP1818	PEP1818	-	-	-	-
	-	-	PEP2525	PEP5025	PEP5025	PEP3030
型材外置 Outside	PEP2510	PEP2510	PEP2510	PEP2510	PEP2510	-
	PEP2518	PEP2518	PEP2518	-	-	-
	PEP2525	PEP2525	PEP2525	PEP2525	PEP2525	-
	PEP5025	PEP5025	PEP5025	PEP5025	PEP5025	-
	PEP4040	PEP4040	PEP4040	PEP4040	PEP4040	-
	PEP3030	PEP3030	PEP3030	PEP3030	PEP3030	PEP3030
<b>螺钉选配件 Accessorier selection</b>						
螺丝(Screws)	PTC-M5L25*2	PTC-M5L25*2	PTC-M5L35*2	PTC-M5L60*2	PTC-M5L35*2	PTC-M5L40*2
双齿平垫(Single hole shim)	PTS-M5*2	PTS-M5*2	PTS-M5*2	PTS-M5*2	PTS-M5*2	PTS-M5*2
T型螺母(T-Nuts)	PTN-M5P28*1	PTN-M5P35*1	PTN-M5P35*1	PTN-M5P35*1	PTN-M5P60*1	PTN-M5P40*1
总重量(Weight)	36g	42g	45g	65g	50g	51g

注: 如需螺钉套件货号 and 型号加T 如: 型号SMBB-1818T 货号7.Y00295-T

Note: If screw kits needed, add T to the part number and model number. eg: Model SMBB-1818T Part number 7.Y00295-T

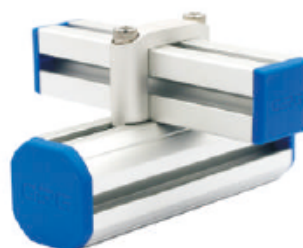

# 方形交叉型材连接件

## Cross (Square) Joint Connector



(螺钉套件选配) (Kit With Screws Option)

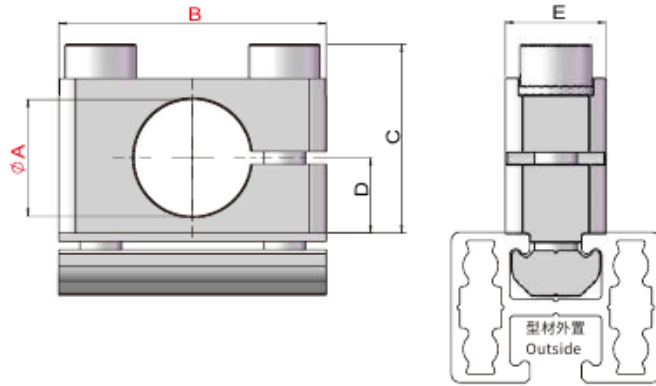

货号(PN)	7.Y00296	7.Y00297	7.Y00013	7.Y00226	7.Y00225
型号(Model)	SMBC-1025	SMBC-1432	SMBC-2038	SMBC-3050	SMBC-5070
A(mm)	Ø10	Ø14	Ø20	Ø30	Ø50
B(mm)	25	32	38	50	70
C(mm)	18	22	25	34.5	56
D(mm)	6.5	9.25	12.5	17.5	28
E(mm)	10	12	15	20	25
型材外置 Outside	PEP1818	PEP1818	PEP1818	PEP1818	PEP1818
	PEP2510	PEP2510	PEP2510	PEP2510	PEP2510
	PEP2518	PEP2518	-	-	-
	PEP2525	PEP2525	PEP2525	PEP2525	PEP2525
	PEP5025	PEP5025	PEP5025	PEP5025	PEP5025
	PEP4040	PEP4040	PEP4040	PEP4040	PEP4040
	PEP3030	PEP3030	PEP3030	PEP3030	PEP3030
螺钉选配件 Accessorier selection					
螺丝(Screws)	PTC-M5L20*2	PTC-M5L22*2	PTC-M5L25*2	PTC-M5L35*2	PTC-M5L50*2
双齿平垫(Single hole shim)	PTS-M5*2	PTS-M5*2	PTS-M5*2	PTS-M5*2	PTS-M5*2
T型螺母(T-Nuts)	PTN-M5P17*1	PTN-M5P22*1	PTN-M5P28*1	PTN-M5P40*1	PTN-M5P60*1
总重量(Weight)	15g	32g	45g	75g	150g

注: 如需螺钉套件货号 and 型号加T 如: 型号SMBC-1025T 货号7.Y00296-T

Note: If screw kits needed, add T to the part number and model number. eg: Model SMBC-1025T Part number 7.Y00296-T



Profile- SUS Tube  
型材、钢管

Stents Module  
支架模组

Quick Changer  
快换

Grip Module  
夹具组件

Air Nipper  
气动剪刀

Vacuum Module  
真空组件

Accessory Components  
附件

# 方形交叉型材连接件 NEW

## Cross (Square) Joint Connector

Profile, SUS Tube  
型材、钢管

Stents Module  
支架模组

Quick Changer  
快换

Grip Module  
夹具组件

Air Nipper  
气动剪刀

Vacuum Module  
真空组件

Accessory Components  
附件



(螺钉套件选配) (Kit With Screws Option)

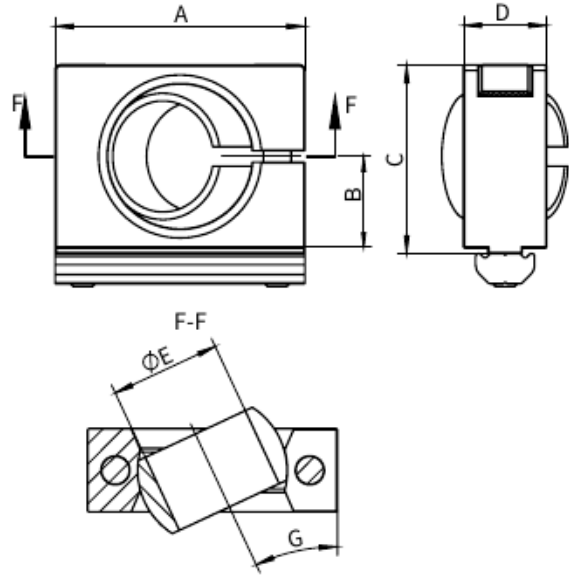

货号(PN)	型号(Model)	A(mm)	B(mm)	C(mm)	D(mm)	E(mm)	G	重量(Weight)
7.Y02033	SMBC8-1025	30	10	20	10	10	22°	33g
7.Y02034	SMBC8-1432	38	12.75	24.5	12	14	25°	47g
7.Y02035	SMBC8-2038	45	17.5	34	15	20	25°	82g

注: 如需螺钉套件货号 and 型号加 **T** 如: 型号 SMBC8-1025**T** 货号 7.Y02033-**T**

Note: If screw kits needed, add **T** to the part number and model number. eg: Model SMBC8-1025T Part number 7.Y02033-T

# 垂直型材连接件

## Vertical Fastening Of The Profiles



(螺钉套件选配) (Kit With Screws Option)

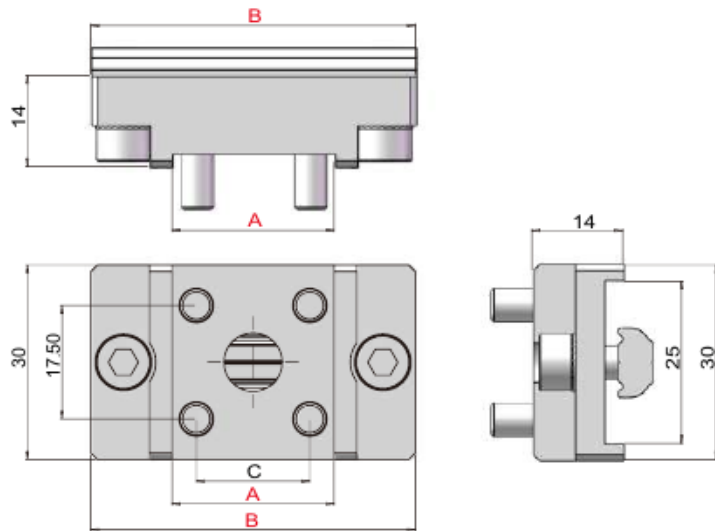

货号(PN)	7.Y00227	7.Y00228
型号(Model)	SMBD-2550	SMBD-5070
A(mm)	25	50
B(mm)	50	70
C(mm)	17.5	42.5
PEP2525	√	√
PEP5025	√	√
<b>螺钉选配件 Accessorier selection</b>		
螺丝(Screws)	PTC-M5L12*6	PTC-M5L12*6
双齿平垫(Single hole shim)	PTS-M5*2	PTS-M5*2
T型螺母(T-Nuts)	PTN-M5P40*1	PTN-M5P60*1
总重量(Weight)	65g	85g

注: 如需螺钉套件货号 and 型号加 T 如: 型号 SMBD-2550 T 货号 7.Y00227-T

Note: If screw kits needed, add T to the part number and model number. eg: Model SMBD-2550 T Part number 7.Y00227-T



型材、钢管  
Profile、SUS Tube

支架模组  
Stents Module

快换  
Quick Changer

夹具组件  
Grip Module

气动剪刀  
Air Nipper

真空组件  
Vacuum Module

附件  
Accessory Components

# 型材连接件

## Profiles Connector

Profile, SUS Tube  
型材、钢管

Stents Module  
支架模组

Quick Changer  
快换

Grip Module  
夹具组件

Air Nipper  
气动剪刀

Vacuum Module  
真空组件

Accessory Components  
附件



(不含螺钉套件) (Not Including Kit With Screws)

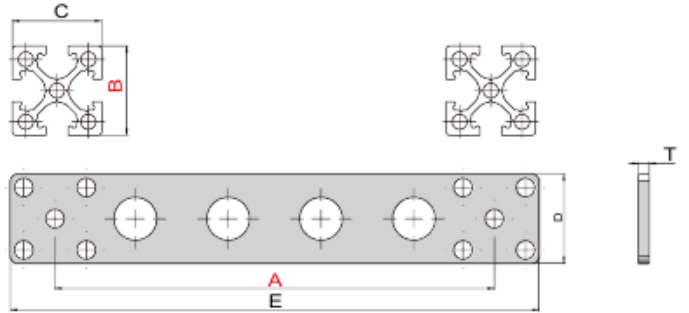

货号(PN)	7.Y00426	7.Y00427	7.Y00428	7.Y00429	7.Y00430	7.Y00431
型号(Model)	SMBD2-7625	SMBD2-12025	SMBD2-13025	SMBD2-7650	SMBD2-12050	SMBD2-13050
A(mm)	76	120	130	76	120	130
B(mm)	25	25	25	50	50	50
C(mm)	25	25	25	25	25	25
D(mm)	28	28	28	53	53	53
E(mm)	104	148	158	104	148	158
T(mm)	2	2	2	2	2	2
PEP2525	√	√	√	-	-	-
PEP5025	-	-	-	√	√	√
总重量(Weight)	50g	60g	65g	75g	100g	110g



# 型材的角支架

## Angle Bracket For Profiles



7.Y00812 7.Y00814

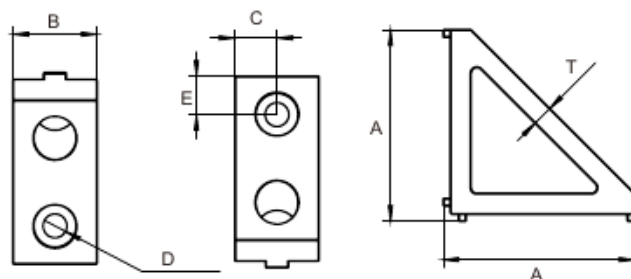

7.Y00813 7.Y00815  
(螺钉套件选配) (Kit With Screws Option)

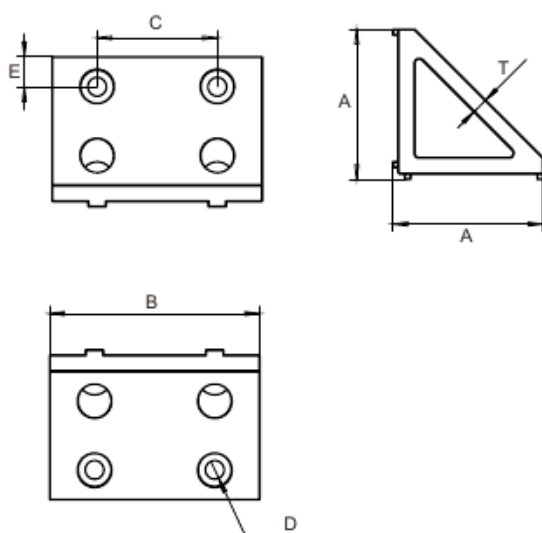

货号(PN)	7.Y00812	7.Y00813	7.Y00814	7.Y00815
型号(Model)	SMBD3-2525	SMBD3-2550	SMBD3-4040	SMBD3-4080
A(mm)	28	28	50	50
B(mm)	18	40	22	70
C(mm)	9	25	11	40
D(mm)	Ø5.2	Ø5.2	Ø6.2	Ø6.2
E(mm)	6	6	10	10
T(mm)	3.2	3.2	5.5	5.5
型材	PEP1818 PEP2510 PEP2518 PEP2525	PEP2550	PEP4040 PEP4080	PEP4080
<b>螺钉选配件 Accessorier selection</b>				
螺丝(Screws)	PTC-M5L12*2	PTC-M5L12*4	PTC-M6L14*2	PTC-M6L16*4
双齿平垫(Single hole shim)	PTS-M5*2	PTS-M5*4	PTS-M6*2	PTS-M6*4
T型螺母(T-Nuts)	PTN-M5*2	PTN-M5*4	PTN-M6*2	PTN-M6*4
总重量(Weight)	27g	58g	63g	190g

注: 如需螺钉套件货号 and 型号加 T 如: 型号 SMBD3-2525T 货号 7.Y00812-T

Note: If screw kits needed, add T to the part number and model number. eg: Model SMBD3-2525T Part number 7.Y00812-T

Profile- SUS Tube  
型材、钢管

Stents Module  
支架模组

Quick Changer  
快换

Grip Module  
夹具组件

Air Nipper  
气动剪刀

Vacuum Module  
真空组件

Accessory Components  
附件

# 平直连接器

## Flat Straight Connector

Profile, SUS Tube  
型材、钢管

Stents Module  
支架模组

Quick Changer  
快换

Grip Module  
夹具组件

Air Nipper  
气动剪刀

Vacuum Module  
真空组件

Accessory Components  
附件



(螺钉套件选配) (Kit With Screws Option)

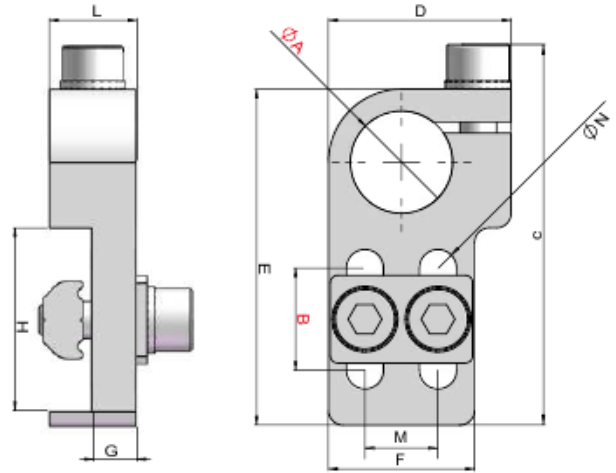

货号(PN)	7.Y00300	7.Y00301	7.Y00775	7.Y00864	7.Y00302	7.Y00014	7.Y00304
型号(Model)	SMBE-1010	SMBE-1014	SMBE-1210	SMBE-1214	SMBE-1414	SMBE-2014	SMBE-2022
A(mm)	Ø10	Ø10	Ø12	Ø12	Ø14	Ø20	Ø20
B(mm)	10	14	10	14	14	14	22
C(mm)	43	49	43	50	51.50	57	73.50
D(mm)	20	20	20.5	20.5	25	30	30
E(mm)	38	44	38	45	46	51.5	68
F(mm)	16	16	16	16	20	25	25
G(mm)	4.5	4.5	4.5	4.5	6	6	6
H(mm)	18	25	18	25	25	25	40
L(mm)	8	8	8	8	12	12	12
M(mm)	8	8	8	8	10	15	15
N(mm)	Ø4.2	Ø4.2	Ø4.2	Ø4.2	Ø5.2	Ø5.2	Ø5.2
PEP1818	√	-	√	-	-	-	-
PEP2510	-	√	-	√	√	√	-
PEP2518	-	√	-	-	√	√	-
PEP2525	-	√	-	-	√	√	-
PEP5025	-	√	-	-	√	√	-
PEP4040	-	-	-	-	-	-	√

### 螺钉选配件 Accessories selection

螺丝(Screws)	PTC-M4L14*2	PTC-M4L14*2	PTC-M4L14*3	PTC-M4L14*3	PTC-M5L16*2	PTC-M5L16*2	PTC-M5L16*2
	PTC-M4L12*1	PTC-M4L12*1	-	-	PTC-M5L14*1	PTC-M5L14*1	PTC-M5L14*1
双齿平垫(Single hole shim)	PTS-M4*3	PTS-M4*3	PTS-M4*3	PTS-M4*3	PTS-M5*3	PTS-M5*3	PTS-M5*3
T型螺母(T-Nuts)	PTN-M4P8*1	PTN-M4P8*1	PTN-M4P8*1	PTN-M4P8*1	PTN-M5P10*1	PTN-M5P15*1	PTN-M5P15*1
双孔平垫(Double hole shim)	PTD-M4P8*1	PTD-M4P8*1	PTD-M4P8*1	PTD-M4P8*1	PTD-M5P10*1	PTD-M5P15*1	PTD-M5P15*1
总重量(Weight)	20g	21g	22g	10g	34g	45g	48g

注: 如需螺钉套件货号和型号加T 如: 型号SMBE-1010T 货号7.Y00300-T

Note: If screw kits needed, add T to the part number and model number. eg: Model SMBE-1010T Part number 7.Y00300-T

# 固定支架

## Mounting Bracket



(螺钉套件选配) (Kit With Screws Option)

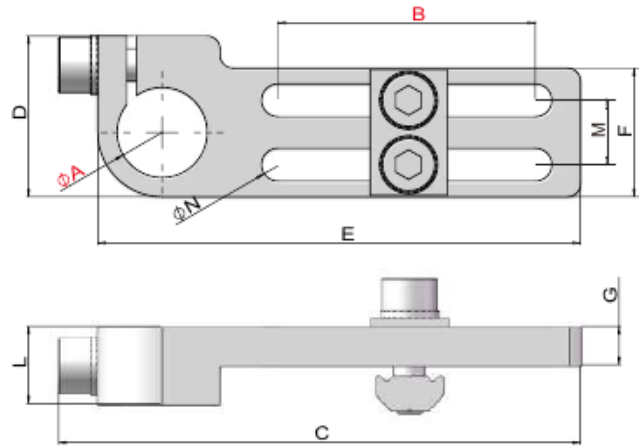

货号(PN)	7.Y00694	7.Y00201	7.Y00695	7.Y00200	7.Y00199	7.Y00015	7.Y00724
型号(Model)	SMBE1-0840	SMBE1-1040	SMBE1-1240	SMBE1-1440	SMBE1-1450	SMBE1-2060	SMBE1-3060
A(mm)	Ø8	Ø10	Ø12	Ø14	Ø14	Ø20	Ø30
B(mm)	40	40	40	40	50	60	60
C(mm)	75	75	75	80.50	90.50	110.50	120.50
D(mm)	20	20	20	25	25	30	40
E(mm)	70	70	70	75	85	105	115
F(mm)	16	16	16	20	20	25	35
G(mm)	4.5	4.5	4.5	6	6	6	8
L(mm)	8	8	8	12	12	12	12
M(mm)	8	8	8	10	10	15	22
N(mm)	Ø4.2	Ø4.2	Ø4.2	Ø5.2	Ø5.2	Ø5.2	Ø5.2
PEP1818	√	√	√	√	√	√	√
PEP2510	√	√	√	√	√	√	√
PEP2518	√	√	√	√	√	√	√
PEP2525	√	√	√	√	√	√	√
PEP5025	√	√	√	√	√	√	√
PEP4040	-	-	-	√	√	√	√
PEP3030	√	√	√	√	√	√	√

### 螺钉选配件 Accessorier selection

螺丝(Screws)	PTC-M4L14*2	PTC-M4L14*2	PTC-M4L14*2	PTC-M5L16*2	PTC-M5L16*2	PTC-M5L16*2	PTC-M5L18*2
	PTC-M4L12*1	PTC-M4L12*1	PTC-M4L12*1	PTC-M5L12*1	PTC-M5L12*1	PTC-M5L14*1	PTC-M5L20*1
双齿平垫 (Single hole shim)	PTS-M4*3	PTS-M4*3	PTS-M4*3	PTS-M5*3	PTS-M5*3	PTS-M5*3	PTS-M5*3
T型螺母 (T-Nuts)	PTN-M4P8*1	PTN-M4P8*1	PTN-M4P8*1	PTN-M5P10*1	PTN-M5P10*1	PTN-M5P15*1	PTN-M5P22*1
双孔平垫 (Double holes shim)	PTD-M4P8*1	PTD-M4P8*1	PTD-M4P8*1	PTD-M5P10*1	PTD-M5P10*1	PTD-M5P15*1	PTD-M5P22*1
总重量 (Weight)	13g	23g	12g	38g	40g	55g	95g

注: 如需螺钉套件货号 and 型号加 T 如: 型号 SMBE1-0840T 货号 7.Y00694-T

Note: If screw kits needed, add T to the part number and model number. eg: Model SMBE1-0840T Part number 7.Y00694-T



Profile- SUS Tube  
型材、钢管

Stents Module  
支架模组

Quick Changer  
快换

Grip Module  
夹具组件

Air Nipper  
气动剪刀

Vacuum Module  
真空组件

Accessory Components  
附件

# 重型固定支架

## Heavy Duty Mounting Bracket

Profile, SUS Tube  
型材、钢管

Stentis Module  
支架模组

Quick Changer  
快换

Grip Module  
夹具组件

Air Nipper  
气动剪刀

Vacuum Module  
真空组件

Accessory Components  
附件



(螺钉套件选配) (Kit With Screws Option)

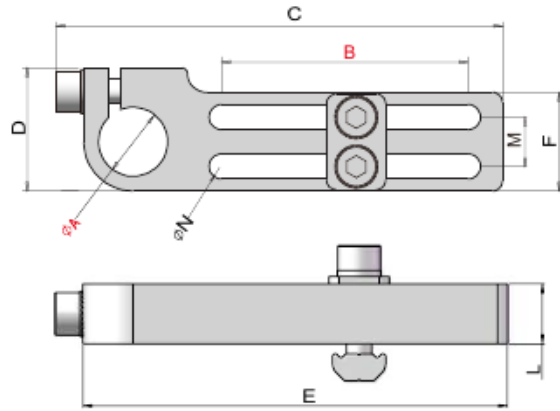

货号(PN)	7.Y00725	7.Y00777	7.Y00307	7.Y00308	7.Y00309
型号(Model)	SMBE2-1040	SMBE2-1240	SMBE2-1450	SMBE2-2060	SMBE2-3060
A(mm)	Ø10	Ø12	Ø14	Ø20	Ø30
B(mm)	40	40	50	60	60
C(mm)	75	75	91	111	122
D(mm)	20	20.5	25	30	42
E(mm)	70	70	85	105	115
F(mm)	16	16	20	25	35
L(mm)	8.3	8.3	12	15	20
M(mm)	8	8	10	15	22
N(mm)	Ø4.2	Ø4.2	Ø5.2	Ø5.2	Ø5.2
螺钉选配件 Accessorier selection					
螺丝(Screws)	PTC-M4L18*2	PTC-M4L18*2	PTC-M5L22*2	PTC-M5L25*2	PTC-M5L30*2
	PTC-M4L12*1	PTC-M4L12*1	PTC-M5L14*1	PTC-M5L16*1	PTC-M6L20*1
双齿平垫(Single hole shim)	PTS-M4*3	PTS-M4*3	PTS-M5*3	PTS-M5*3	PTS-M5*2
					PTS-M6*1
T型螺母(T-Nuts)	PTN-M4P8*1	PTN-M4P8*1	PTN-M5P10*1	PTN-M5P15*1	PTN-M5P22*1
双孔平垫(Double holes shim)	PTD-M4P8*1	PTD-M4P8*1	PTD-M5P10*1	PTD-M5P15*1	PTD-M5P22*1
总重量(Weight)	30g	40g	60g	85g	175g

注: 如需螺钉套件货号和型号加T 如: 型号SMBE2-1040T 货号7.Y00725-T

Note: If screw kits needed, add T to the part number and model number. eg: Model SMBE2-1040T Part number 7.Y00725-T



## 带有球关节重型固定支架

### Heavy Duty Fixing Bracket With Ball Joint



(螺钉套件选配) (Kit With Screws Option)

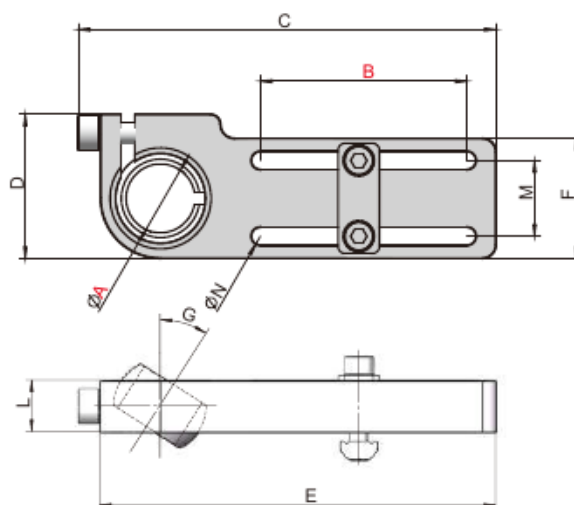

货号(PN)	7.Y02014	7.Y02015	7.Y02012
型号(Model)	SMBE8-1050	SMBE8-1460	SMBE8-2060
A(mm)	Ø10	Ø14	Ø20
B(mm)	50	60	60
C(mm)	89.5	111.5	121.8
D(mm)	25	31	42
E(mm)	85	105	115
F(mm)	20	25	35
G(mm)	0-26°	0-26°	0-26°
L(mm)	8.3	12	15
M(mm)	10	15	22

#### 螺钉选配件 Accessorier selection

螺丝(Screws)	PTC-M4L14*1	PTC-M5L18*1	PTC-M6L18*1
	PTC-M5L18*2	PTC-M5L22*2	PTC-M5L25*2
双齿平垫(Single hole shim)	PTS-M5*2	PTS-M5*3	PTS-M5*2
	PTS-M4*1		PTS-M6*1
T型螺母(T-Nuts)	PTN-M5P10*1	PTN-M5P15*1	PTN-M5P22*1
双孔平垫(Double holes shim)	PTD-M5P10*1	PTD-M5P15*1	PTD-M5P22*1
总重量(Weight)	85g	130g	170g

注: 如需螺钉套件货号 and 型号加T 如: 型号SMBE8-1050T 货号7.Y02014-T

Note: If screw kits needed, add T to the part number and model number. eg: Model SMBE8-1050T Part number 7.Y02014-T



Profile- SUS Tube  
型材、钢管

Stents Module  
支架模组

Quick Changer  
快换

Grip Module  
夹具组件

Air Nipper  
气动剪刀

Vacuum Module  
真空组件

Accessory Components  
附件

## 角度可调连接件 Slotted Angular Bracket

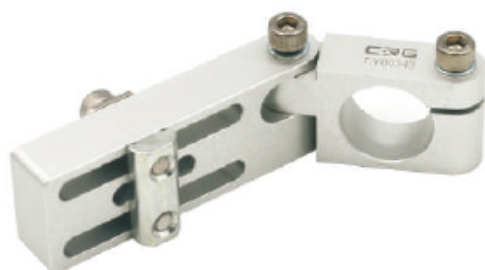

(螺钉套件选配) (Kit With Screws Option)

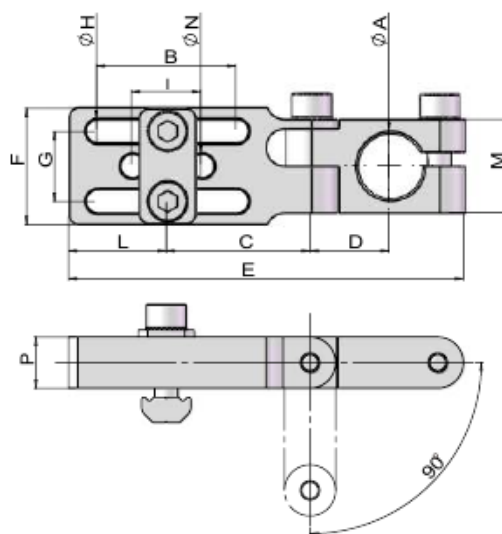

货号(PN)	7.Y00341	7.Y00795	7.Y00342	7.Y00343	7.Y02009	7.Y00344
型号(Model)	SMBE3-1020	SMBE3-1220	SMBE3-1430	SMBE3-2040	SMBE3-2060	SMBE3-3050
A(mm)	Ø10	Ø12	Ø14	Ø20	Ø20	Ø30
B(mm)	20	20	30	40	60	50
C(mm)	23	23	31	39	68	50
D(mm)	14	14	17	22	22	28
E(mm)	64.5	65.50	85	107	146	135.5
F(mm)	16	16	25	25	25	36
G(mm)	8	8	15	15	15	22
H(mm)	4.2	4.2	5.2	5.2	5.2	5.2
I(mm)	-	-	15	15	15	22
L(mm)	15	15	21	26	36	31
M(mm)	16	16	20	25	25	36
N(mm)	-	-	Ø5.2	Ø5.2	Ø5.2	Ø5.2
P(mm)	9	9	11	13	13	16

### 螺钉选配件 Accessorier selection

螺丝(Screws)	PTC-M4L18*2 PTC-M4L16*2	PTC-M4L18*2 PTC-M4L16*2	PTC-M5L20*4 -	PTC-M5L22*2 PTC-M5L25*2	PTC-M5L22*2 PTC-M5L25*2	PTC-M5L25*2 PTC-M5L35*2
双齿平垫(Single hole shim)	PTS-M4*4	PTS-M4*4	PTS-M5*4	PTS-M5*4	PTS-M5*4	PTS-M5*4
T型螺母(T-Nuts)	PTN-M4P8*1	PTN-M4P8*1	PTN-M5P15*1	PTN-M5P15*1	PTN-M5P15*1	PTN-M5P22*1
双孔平垫(Double holes shim)	PTD-M4P8*1	PTD-M4P8*1	PTD-M5P15*1	PTD-M5P15*1	PTD-M5P15*1	PTD-M5P22*1
总重量(Weight)	30g	35g	50g	90g	117g	185g

注: 如需螺钉套件货号 and 型号加 T 如: 型号 SMBE3-1020 T 货号 7.Y00341-T

Note: If screw kits needed, add T to the part number and model number. eg: Model SMBE3-1020 T Part number 7.Y00341-T



# 固定支架

## Mounting Bracket

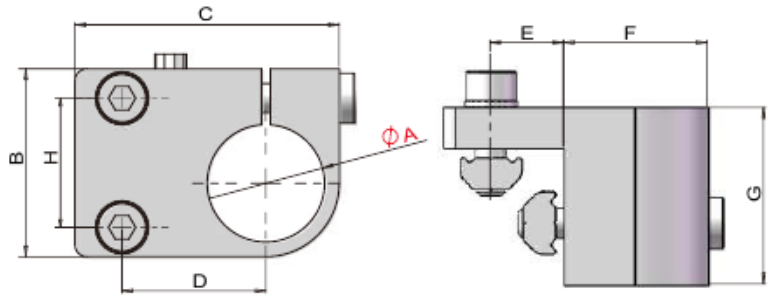

(螺钉套件选配) (Kit With Screws Option)

货号(PN)	7.Y00224	7.Y00223	7.Y00181	7.Y00222	7.Y00221
型号(Model)	SMBE4-1412	SMBE4-2012	SMBE4-2020	SMBE4-3012	SMBE4-3020
A(mm)	Ø14	Ø20	Ø20	Ø30	Ø30
B(mm)	25	32	35	40	45
C(mm)	40	45	54.5	55	65.5
D(mm)	22	24.5	33	29.5	39
E(mm)	12.5	12.5	20	12.5	20
F(mm)	19.5	24.5	26.5	34.5	37.5
G(mm)	25	30	35	30	40
H(mm)	15	22	25	30	35
PEP1818	√	√	-	√	-
PEP2510	√	√	-	√	-
PEP2518	√	√	-	√	-
PEP2525	√	√	-	√	-
PEP5025	√	√	-	√	-
PEP4040	-	-	√	-	√

### 螺钉选配件 Accessorier selection

螺丝(Screws)	PTC-M5L14*2 PTC-M5L25*1	PTC-M5L16*2 PTC-M5L30*1	PTC-M5L16*2 PTC-M5L30*1	PTC-M5L16*2 PTC-M5L35*1	PTC-M5L16*2 PTC-M5L40*1
双齿平垫(Single hole shim)	PTS-M5*3	PTS-M5*3	PTS-M5*3	PTS-M5*3	PTS-M5*3
T型螺母(T-Nuts)	PTN-M5P15*1 PTN-M5*1	PTN-M5P22*1 PTN-M5*1	PTN-M5P25*1 PTN-M5*1	PTN-M5P30*1 PTN-M5*1	PTN-M5P35*1 PTN-M5*1
总重量(Weight)	50g	70g	95g	90g	150g

注: 如需螺钉套件货号 and 型号加 T 如: 型号SMBE4-1412T 货号7.Y00224-T

Note: If screw kits needed, add T to the part number and model number. eg: Model SMBE4-1412T Part number 7.Y00224-T



Profile- SUS Tube  
型材、钢管

Stents Module  
支架模组

Quick Changer  
快换

Grip Module  
夹具组件

Air Nipper  
气动剪刀

Vacuum Module  
真空组件

Accessory Components  
附件

# 固定支架

## Mounting Bracket

Profile, SUS Tube  
型材、钢管

Stents Module  
支架模组

Quick Changer  
快换

Grip Module  
夹具组件

Air Ripper  
气动剪刀

Vacuum Module  
真空组件

Accessory Components  
附件



(螺钉套件选配) (Kit With Screws Option)

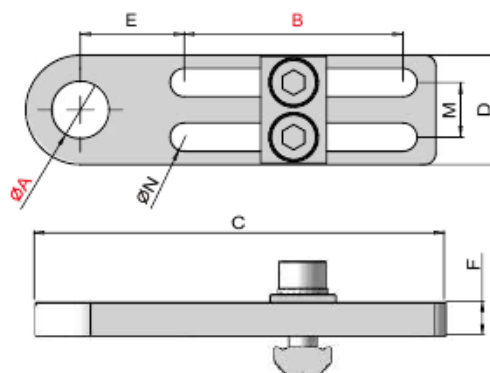

货号(PN)	型号(Model)	A(mm)	B(mm)	C(mm)	D(mm)	E(mm)	F(mm)	M(mm)	N(mm)	重量(Weight)
7.Y00310	SMBE5-G1840	G1/8	40	75	20	19	6	10	Ø5.2	25g
7.Y00311	SMBE5-G1860	G1/8	60	105	25	26.5	6	15	Ø5.2	42g
7.Y00312	SMBE5-M1040	M10×1	40	75	20	19	6	10	Ø5.2	30g
7.Y00313	SMBE5-M1060	M10×1	60	105	25	26.5	6	15	Ø5.2	40g
7.Y00314	SMBE5-M1240	M12×1	40	75	20	19	6	10	Ø5.2	30g
7.Y00315	SMBE5-M1260	M12×1	60	105	25	26.5	6	15	Ø5.2	47g
7.Y00316	SMBE5-M1440	M14×1	40	75	20	19	6	10	Ø5.2	20g
7.Y00317	SMBE5-M1460	M14×1	60	105	25	26.5	6	15	Ø5.2	40g
7.Y00320	SMBE5-M1640	M16×1	40	75	20	19	6	10	Ø5.2	20g
7.Y00321	SMBE5-M1660	M16×1	60	105	25	26.5	6	15	Ø5.2	40g
7.Y00322	SMBE5-M2040	M20×1	40	75	25	16.5	6	15	Ø5.2	30g
7.Y00323	SMBE5-M2060	M20×1	60	105	25	26.5	6	15	Ø5.2	35g

### 螺钉选配件 Accessorier selection

#### 选配一 Accessorier selection 1

螺丝(Screws)	PTC-M5L16*2	SMBE5-G1840, SMBE5-M1040,
双齿平垫(Single hole shim)	PTS-M5*2	SMBE5-M1240, SMBE5-M1440,
T型螺母(T-Nuts)	PTN-M5P10*1	SMBE5-M1640
双孔平垫(Double holes shim)	PTD-M5P10*1	

#### 选配二 Accessorier selection 2

螺丝(Screws)	PTC-M5L16*2	SMBE5-G1860, SMBE5-M1060, SMBE5-M1260,
双齿平垫(Single hole shim)	PTS-M5*2	SMBE5-M1460, SMBE5-M1660, SMBE5-M2040,
T型螺母(T-Nuts)	PTN-M5P15*1	SMBE5-M2060
双孔平垫(Double holes shim)	PTD-M5P15*1	

注: 如需螺钉套件货号 and 型号加T 如: 型号SMBE5-G1840T 货号7.Y00310-T

Note: If screw kits needed, add T to the part number and model number. eg: Model SMBE5-G1840T Part number 7.Y00310-T



# 固定支架

## Mounting Bracket



(螺钉套件选配) (Kit With Screws Option)

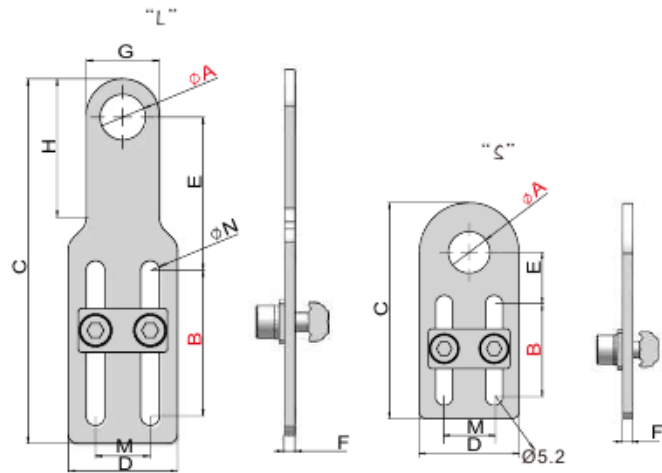

货号(PN)	型号(Model)	A(mm)	B(mm)	C(mm)	D(mm)	E(mm)	F(mm)	G(mm)	H(mm)	M(mm)	N(mm)	重量(Weight)
7.Y00357	SMBE6-1040	Ø10.5	40	100	30	42.5	3	20	38	15	Ø5.2	60g
7.Y00358	SMBE6-1240	Ø12.5	40	100	30	42.5	3	20	38	15	Ø5.2	60g
7.Y00359	SMBE6-1440	Ø14.5	40	100	30	40.5	3	24	38	15	Ø5.2	60g
7.Y00360	SMBE6-1640	Ø16.5	40	100	30	37.5	3	30	-	15	Ø5.2	65g
7.Y00361	SMBE6-2040	Ø20.5	40	100	30	37.5	3	30	-	15	Ø5.2	60g
7.Y00362	SMBE6-2240	Ø22.5	40	100	30	35	5	35	-	15	Ø5.2	105g
7.Y00363	SMBE6-2540	Ø25.5	40	100	30	35	5	35	-	15	Ø5.2	100g
7.Y00364	SMBE6-1028	Ø10.5	28	65	30	15.5	3	-	-	15	Ø5.2	45g
7.Y00365	SMBE6-1228	Ø12.5	28	65	30	15.5	3	-	-	15	Ø5.2	45g
7.Y00366	SMBE6-1428	Ø14.5	28	65	30	15.5	3	-	-	15	Ø5.2	45g
7.Y00367	SMBE6-1628	Ø16.5	28	65	30	15.5	3	-	-	15	Ø5.2	45g
7.Y00368	SMBE6-2028	Ø20.5	28	65	30	15.5	3	-	-	15	Ø5.2	40g
7.Y00369	SMBE6-2228	Ø22.5	28	70	30	18	5	35	-	15	Ø5.2	75g
7.Y00370	SMBE6-2528	Ø25.5	28	70	30	18	5	35	-	15	Ø5.2	70g

### 螺钉选配件 Accessorier selection

#### 选配一 Accessorier selection 1

螺丝(Screws)	PTC-M5L12*2	SMBE6-1040, SMBE6-1240, SMBE6-1440
双齿平垫(Single hole shim)	PTS-M5*2	SMBE6-1640, SMBE6-2040, SMBE6-1028
T型螺母(T-Nuts)	PTN-M5P15*1	SMBE6-1228, SMBE6-1428, SMBE6-1628
双孔平垫(Double holes shim)	PTD-M5P15*1	SMBE6-2028

#### 选配二 Accessorier selection 2

螺丝(Screws)	PTC-M5L14*2	SMBE6-2240, MBE6-2540
双齿平垫(Single hole shim)	PTS-M5*2	SMBE6-2228, SMBE6-2528
T型螺母(T-Nuts)	PTN-M5P15*1	
双孔平垫(Double holes shim)	PTD-M5P15*1	

注: 如需螺钉套件货号 and 型号加T 如: 型号SMBE6-1040T 货号7.Y00357-T

Note: If screw kits needed, add T to the part number and model number. eg: Model SMBE6-1040T Part number 7.Y00357-T

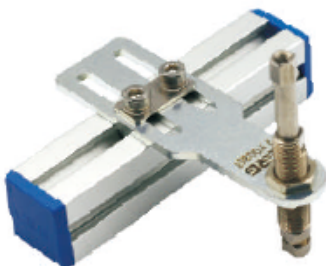

Profile- SUS Tube  
型材、钢管

Stents Module  
支架模组

Quick Changer  
快换

Grip Module  
夹具组件

Air Nipper  
气动剪刀

Vacuum Module  
真空组件

Accessory Components  
附件

## 气缸支架 Cylinder Bracket

Profile, SUS Tube  
型材、钢管

Stents Module  
支架模组

Quick Changer  
快换

Grip Module  
夹具组件

Air Nipper  
气动剪刀

Vacuum Module  
真空组件

Accessory Components  
附件

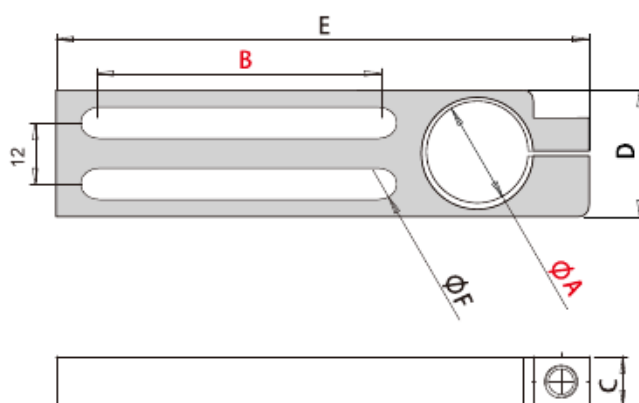

货号(PN)	型号(Model)	A	B	C	D	E	F	重量(Weight)
7.Y00062	SMBE7-0856	Ø8	56	10	25	90	6.5	40g
7.Y00021	SMBE7-1256	Ø12	56	10	25	95	6.5	43g
7.Y00006	SMBE7-2056	Ø20	56	10	25	105	6.5	47g

## 球关节角度可调连接件 NEW Adjustable ball joint connector

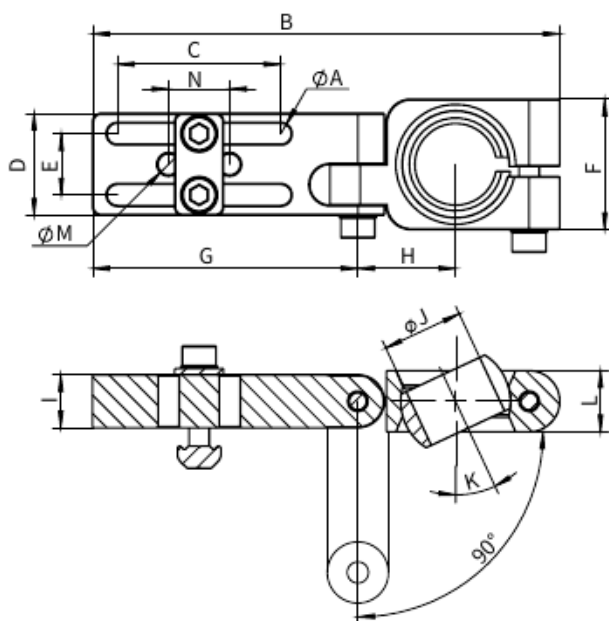

货号(PN)	型号(Model)	A	B	C	D	E	F	G	H	I	J	K	L	M	N	重量(Weight)
7.Y02036	SMBE9-1020	Ø4.2	67.5	20	16	8	20	38	14.5	9	Ø10	23°	9	-	-	38g
7.Y02037	SMBE9-1430	Ø5.2	91	30	25	15	24	52	18.5	11	Ø14	25°	12	Ø5.2	15	78g
7.Y02038	SMBE9-2040	Ø5.2	114.6	40	25	15	32	65	24	13	Ø20	25°	15	Ø5.2	15	121g

注: 如需螺钉套件货号 and 型号加T 如: 型号SMBE9-1020T 货号7.Y02036-T

Note: If screw kits needed, add T to the part number and model number. eg: Model SMBE9-1020T Part number 7.Y02036-T

# 汇流排

## Side Manifold Block

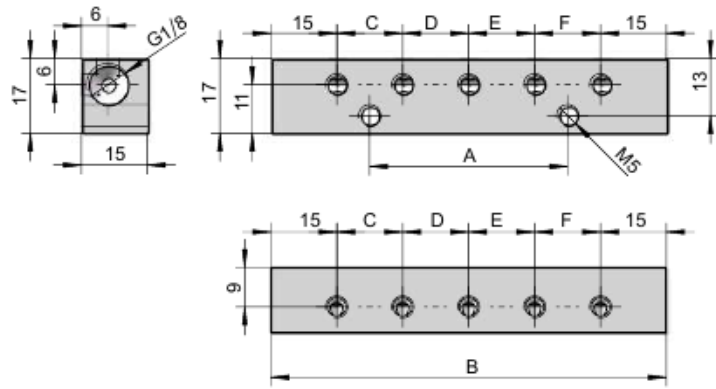

货号(PN)	型号(Model)	A	B	C	D	E	F	重量(Weight)
7.Y00153	SMB-10M5-02G18	45	90	15	15	15	15	51g
7.Y00154	SMB-08M5-02G18	30	75	15	15	15	-	42g

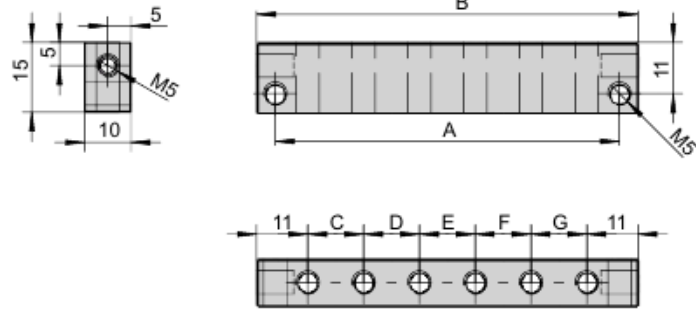

货号(PN)	型号(Model)	A	B	C	D	E	F	G	重量(Weight)
7.Y00157	SMB-06M5	26	34	12	-	-	-	-	10g
7.Y00156	SMB-08M5	38	46	12	12	-	-	-	14g
7.Y00155	SMB-10M5	50	58	12	12	12	-	-	18g
7.Y00167	SMB-14M5	74	82	12	12	12	12	12	26g

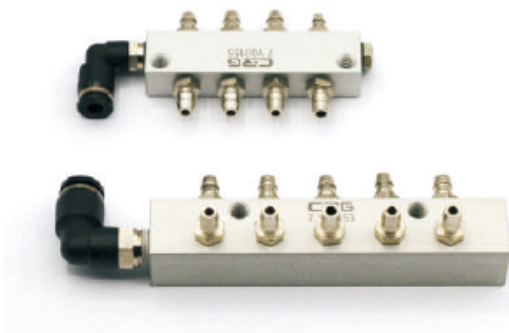

Profile- SUS Tube  
型材、钢管

Stents Module  
支架模组

Quick Changer  
快换

Grip Module  
夹具组件

Air Nipper  
气动剪刀

Vacuum Module  
真空组件

Accessory Components  
附件

# 汇流排

## Side Manifold Block

G1/8(x5)

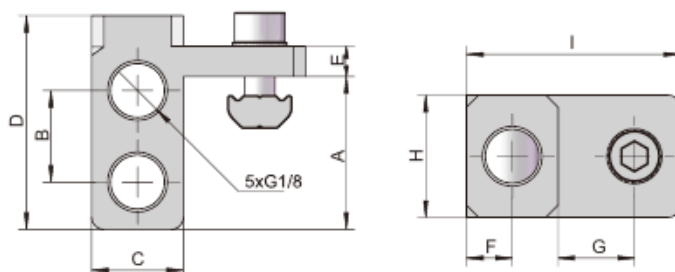

(螺钉套件选配) (Kit With Screws Option)

货号 (PN)	7.Y00229	7.Y01020	7.Y01022
型号 (Model)	SMB-5G18	SMB1-5G18	SMB2-5G18
A(mm)	25	25	25
B(mm)	15	15	15
C(mm)	15	15	15
D(mm)	35	35	35
E(mm)	5	5	5
F(mm)	7.50	7.50	7.50
G(mm)	12.50	15	20
H(mm)	20	20	20
I(mm)	35	40	45
PEP1818	√	-	-
PEP2510	√	-	-
PEP2518	√	-	-
PEP2525	√	-	-
PEP5025	√	-	-
PEP3030	-	√	-
PEP4040	-	-	√
螺钉选配件 Accessorier selection			
螺丝 (Screws)	PTC-M5L14*1	PTC-M5L14*1	PTC-M5L14*1
双齿平垫 (Single hole shim)	PTS-M5*1	PTS-M5*1	PTS-M5*1
T型螺母 (T-Nuts)	PTN-M5*1	PTN-M5*1	PTN-M5*1
总重量 (Weight)	30g	33g	34g

注: 如需螺钉套件货号 and 型号加 T 如: 型号 SMB-5G18 T 货号 7.Y00229-T

Note: If screw kits needed, add T to the part number and model number. eg: Model SMB-5G18 T Part number 7.Y00229-T

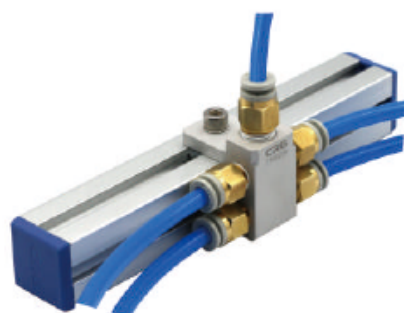

Profile、SUS Tube  
型材、钢管

Stents Module  
支架模组

Quick Changer  
快换

Grip Module  
夹具组件

Air Nipper  
气动剪刀

Vacuum Module  
真空组件

Accessory Components  
附件

# 汇流排

## Side Manifold Block

G1/8(x9)

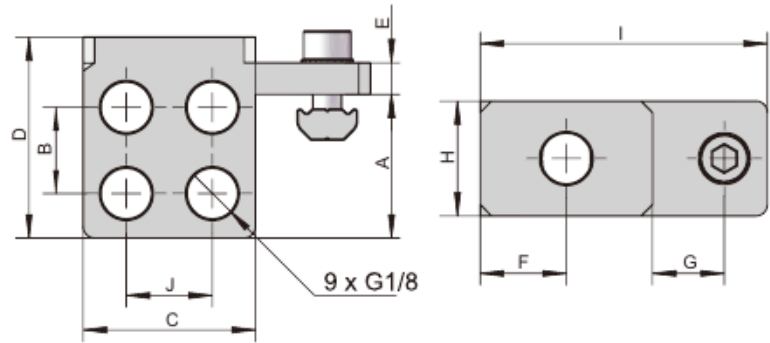

(螺钉套件选配) (Kit With Screws Option)

货号(PN)	7.Y00231	7.Y01021	7.Y01023
型号(Model)	SMB-9G18	SMB1-9G18	SMB2-9G18
A(mm)	25	25	25
B(mm)	15	15	15
C(mm)	30	30	30
D(mm)	35	35	35
E(mm)	5.50	5.50	5.50
F(mm)	15	15	15
G(mm)	12.50	15	20
H(mm)	20	20	20
I(mm)	50	55	60
J(mm)	15	15	15
PEP1818	√	-	-
PEP2510	√	-	-
PEP2518	√	-	-
PEP2525	√	-	-
PEP5025	√	-	-
PEP3030	-	√	-
PEP4040	-	-	√
<b>螺钉选配件 Accessorier selection</b>			
螺丝(Screws)	PTC-M5L14*1	PTC-M5L14*1	PTC-M5L14*1
双齿平垫(Single hole shim)	PTS-M5*1	PTS-M5*1	PTS-M5*1
T型螺母(T-Nuts)	PTN-M5*1	PTN-M5*1	PTN-M5*1
总重量(Weight)	50g	52g	54g

注: 如需螺钉套件货号 and 型号加**T** 如: 型号SMB-9G18**T** 货号7.Y00231-**T**

Note: If screw kits needed, add **T** to the part number and model number. eg: Model SMB-9G18**T** Part number 7.Y00231-**T**



Profile- SUS Tube  
型材、钢管

Stents Module  
支架模组

Quick Changer  
快换

Grip Module  
夹具组件

Air Nipper  
气动剪刀

Vacuum Module  
真空组件

Accessory Components  
附件

# 双通道汇流排

## Side Manifold Block

G1/8(5+5)



(螺钉套件选配) (Kit With Screws Option)

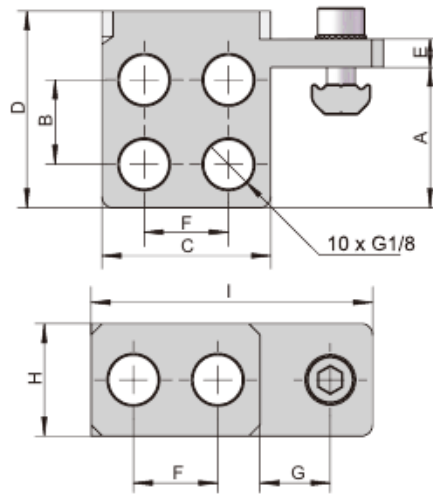

Profile, SUS Tube  
型材、钢管

Stentis Module  
支架模组

Quick Changer  
快换

Grip Module  
夹具组件

Air Nipper  
气动剪刀

Vacuum Module  
真空组件

Accessory Components  
附件

货号(PN)	7.Y00230	7.Y01024	7.Y01025
型号(Model)	SMB-D5G18	SMB1-D5G18	SMB2-D5G18
A(mm)	25	25	25
B(mm)	15	15	15
C(mm)	30	30	30
D(mm)	35	35	35
E(mm)	5	5	5
F(mm)	15	15	15
G(mm)	12.50	15	20
H(mm)	20	20	20
I(mm)	50	55	60
PEP1818	√	-	-
PEP2510	√	-	-
PEP2518	√	-	-
PEP2525	√	-	-
PEP5025	√	-	-
PEP3030	-	√	-
PEP4040	-	-	√
螺钉选配件 Accessorier selection			
螺丝(Screws)	PTC-M5L14*1	PTC-M5L14*1	PTC-M5L14*1
双齿平垫(Single hole shim)	PTS-M5*1	PTS-M5*1	PTS-M5*1
T型螺母(T-Nuts)	PTN-M5*1	PTN-M5*1	PTN-M5*1
总重量(Weight)	48g	51g	52g

注: 如需螺钉套件货号 and 型号加T 如: 型号SMB-D5G18T 货号7.Y00230-T

Note: If screw kits needed, add T to the part number and model number. eg: Model SMB-D5G18T Part number 7.Y00230-T



# 多方位汇流排

## Manifold Block

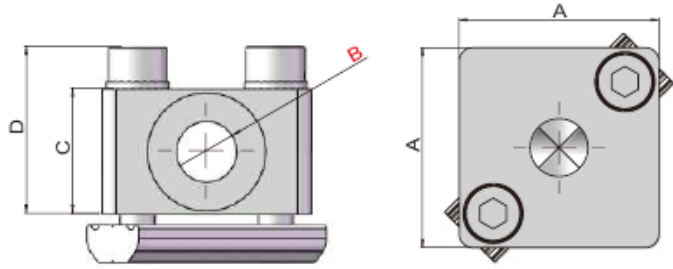

(螺钉套件选配) (Kit With Screws Option)

货号(PN)	7.Y00240	7.Y00241
型号(Model)	SMB-A5G18	SMB-A5G14
A(mm)	30	40
B(mm)	(x5)G1/8	(x5)G1/4
C(mm)	18	20
D(mm)	24	23
螺钉选配件 Accessorier selection		
螺丝(Screws)	PTC-M5L25*2	PTC-M5L25*2
双齿平垫(Single hole shim)	PTS-M5*2	PTS-M5*2
T型螺母(T-Nuts)	PTN-M5P28*1	PTN-M5P35*1
总重量(Weight)	50g	80g

注: 如需螺钉套件货号和型号加T 如: 型号SMB-A5G18T 货号7.Y00240-T

Note: If screw kits needed, add T to the part number and model number. eg: Model SMB-A5G18T Part number 7.Y00240-T



Profile- SUStube  
型材、钢管

Stents Module  
支架模组

Quick Changer  
快换

Grip Module  
夹具组件

Air Nipper  
气动剪刀

Vacuum Module  
真空组件

Accessory Components  
附件

## 空气引导延长管

### Extensio Tube With Air Lead

Profile, SUS Tube  
型材、钢管

Stents Module  
支架模组

Quick Changer  
快换

Grip Module  
夹具组件

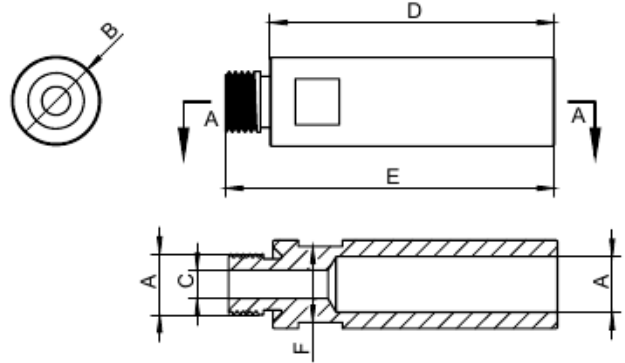

货号(PN)	型号(Model)	A	B	C	D	E	F	重量(Weight)
7.Y02063	SMBY-1050M5	M5	Ø10	Ø2	45	50	8	7.7g
7.Y02064	SMBY-1095M5	M5	Ø10	Ø2	90	95	8	16.4g
7.Y02065	SMBY-1452G18	G1/8	Ø14	Ø4.5	45	52	12	12.6g
7.Y02066	SMBY-1497G18	G1/8	Ø14	Ø4.5	90	97	12	23.8g
7.Y02067	SMBY-2053G14	G1/4	Ø20	Ø6.5	45	53	17	27.0g
7.Y02068	SMBY-2098G14	G1/4	Ø20	Ø6.5	90	98	17	51.9g

## 延长杆

### Extension Tube

Air Nipper  
气动剪刀

Vacuum Module  
真空组件

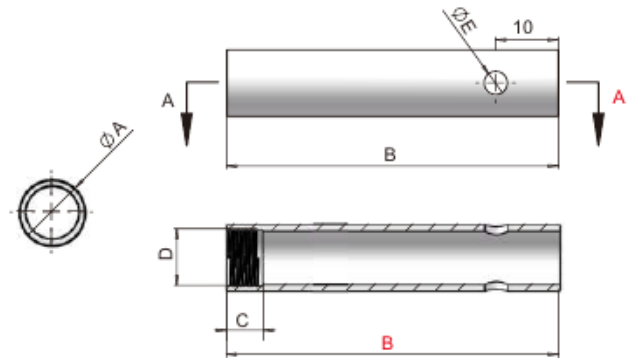

货号(PN)	型号(Model)	A	B	C	D	E	重量(Weight)
7.Y00736	SMBY12-50	Ø12	50	12	M10*1	5	9g
7.Y00735	SMBY12-100	Ø12	100	12	M10*1	5	17g
7.Y00733	SMBY14-50	Ø14	50	12	M12*1	5	10g
7.Y00734	SMBY14-100	Ø14	100	12	M12*1	5	20g
7.Y00732	SMBY20-50	Ø20	50	15	M17*1	8	16g
7.Y00731	SMBY20-100	Ø20	100	15	M17*1	8	31g
7.Y00462	SMBY20-150	Ø20	150	15	M17*1	8	47g
7.Y01027	SMBY25-100	Ø25	100	15	M22*1	8	43g
7.Y00729	SMBY30-50	Ø30	50	18	M27*1	9	29g
7.Y00730	SMBY30-100	Ø30	100	18	M27*1	9	58g
7.Y00463	SMBY30-150	Ø30	150	18	M27*1	9	87g

Accessory Components  
附件

## 连接块.SSW

Connector SSW

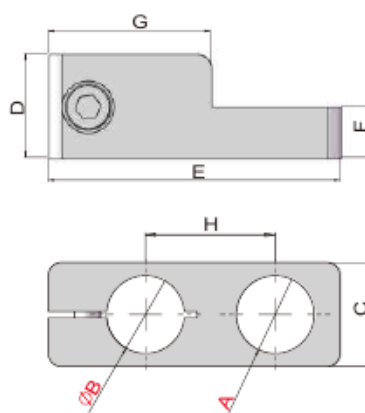

货号(PN)	型号(Model)	A	B	C	D	E	F	G	H	重量(Weight)
7.Y00028	SMBT1-M1412	M14*1	Ø12	16	16	45	8	25	20	16g

## 平行连接块

Parallel Connector

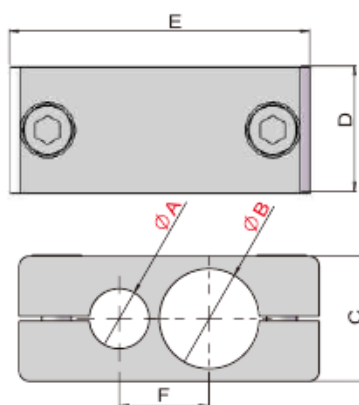

货号(PN)	型号(Model)	A	B	C	D	E	F	重量(Weight)
7.Y00042	SMBP-0808	Ø8	Ø8	12	12	35	10	11g
7.Y00043	SMBP-0812	Ø8	Ø12	16	16	43	12	23g
7.Y00044	SMBP-1212	Ø12	Ø12	16	16	44	14	21g
7.Y00045	SMBP-2012	Ø20	Ø12	25	25	60	18	75g
7.Y00046	SMBP-2020	Ø20	Ø20	25	25	66	24	71g

Profile- SUS Tube  
型材、钢管

Stents Module  
支架模组

Quick Changer  
快换

Grip Module  
夹具组件

Air Nipper  
气动剪刀

Vacuum Module  
真空组件

Accessory Components  
附件

# 十字连接块

## Cross Connector

Profile, SUS Tube  
型材、钢管

Stents Module  
支架模组

Quick Changer  
快换

Grip Module  
夹具组件

Air Nipper  
气动剪刀

Vacuum Module  
真空组件

Accessory Components  
附件

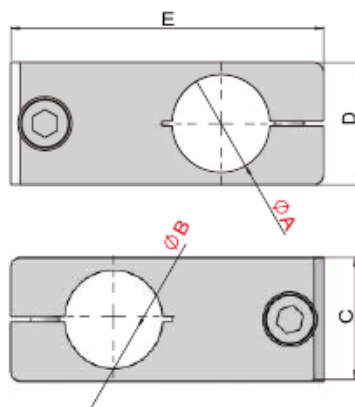

货号(PN)	型号(Model)	A	B	C	D	E	重量(Weight)
7.Y00025	SMBT-0808	Ø8	Ø8	12	12	35	10g
7.Y00026	SMBT-1208	Ø12	Ø8	12	16	43	16g
7.Y00020	SMBT-1212	Ø12	Ø12	16	16	47	22g
7.Y00794	SMBT-1214	Ø12	Ø14	18	18	48	29g
7.Y00027	SMBT-2012	Ø20	Ø12	25	25	59	72g
7.Y00005	SMBT-2020	Ø20	Ø20	25	25	64	68g

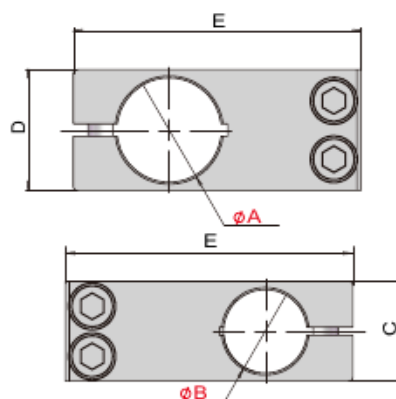

货号(PN)	型号(Model)	A	B	C	D	E	重量(Weight)
7.Y01002	SMBT-1414	Ø14	Ø14	18	18	46	25g
7.Y00998	SMBT-2520	Ø25	Ø20	24	29	69	79g
7.Y00999	SMBT-2525	Ø25	Ø25	30	30	78	114g

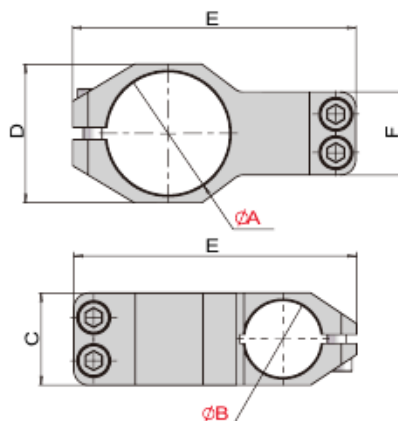

货号(PN)	型号(Model)	A	B	C	D	E	F	重量(Weight)
7.Y02670	SMBT-3025	Ø30	Ø25	30	35	82	25	88g
7.Y01059	SMBT-4020	Ø40	Ø20	25	45	88	27	101g
7.Y01004	SMBT-4025	Ø40	Ø25	30	45	92	27	107g
7.Y02058	SMBT-4030	Ø40	Ø30	35	45	97	32	142g

## 十字连接块

Cross Connector

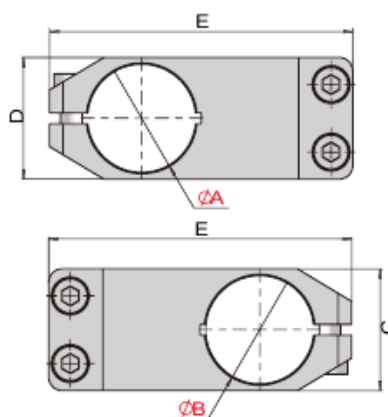

货号(PN)	型号(Model)	A	B	C	D	E	F	重量(Weight)
7.Y01003	SMBT-4040	Ø40	Ø40	45	45	112	112	259g

## 十字连接块

Cross Connection Block

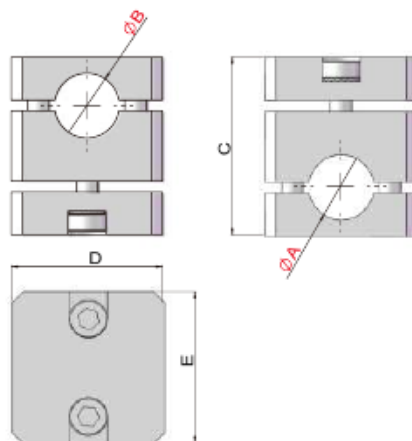

货号(PN)	型号(Model)	A	B	C	D	E	重量(Weight)
7.Y00192	SMBT2-1212	Ø12	Ø12	33	28	28	11g
7.Y00185	SMBT2-2020	Ø20	Ø20	48	42	42	30g
7.Y02020	SMBT2-4040	Ø40	Ø40	91	60	60	393g
7.Y02021	SMBT2-3030	Ø30	Ø30	71	50	50	252g
7.Y02022	SMBT2-2525	Ø25	Ø25	60	43	43	165g
7.Y02025	SMBT2-4025	Ø40	Ø25	75	60	45	271g
7.Y02026	SMBT2-4020	Ø40	Ø20	69	60	40	234g

Profile- SUS Tube  
型材、钢管

Stents Module  
支架模组

Quick Changer  
快换

Grip Module  
夹具组件

Air Nipper  
气动剪刀

Vacuum Module  
真空组件

Accessory Components  
附件

# 十字连接块

## Cross Connection Block

Profile, SUS Tube  
型材、钢管

Stents Module  
支架模组

Quick Changer  
快换

Grip Module  
夹具组件

Air Nipper  
气动剪刀

Vacuum Module  
真空组件

Accessory Components  
附件

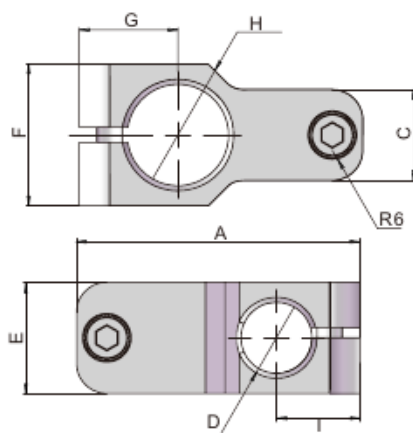

货号(PN)	型号(Model)	A	C	D	E	F	G	H	I	重量(Weight)
7.Y00329	SCD-2010	54	14	Ø10	19	28	19.5	Ø20	14.50	41g
7.Y00330	SCD-2014	56	18	Ø14	22	28	19.5	Ø20	16.50	51g
7.Y01049	SCD-3020	75	18	Ø20	25	35	26	Ø30	20	78g

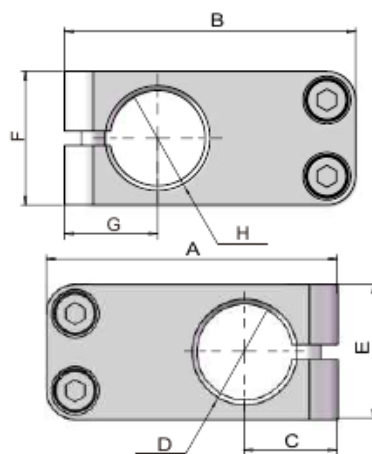

货号(PN)	型号(Model)	A	B	C	D	E	F	G	H	重量(Weight)
7.Y00233	SCD-2020	61	61	19.5	Ø20	28	28	19.5	Ø20	85g
7.Y01050	SCD-3030	84	84	26	Ø30	35	35	26	Ø30	98g



# T字型连接块

## T Connector

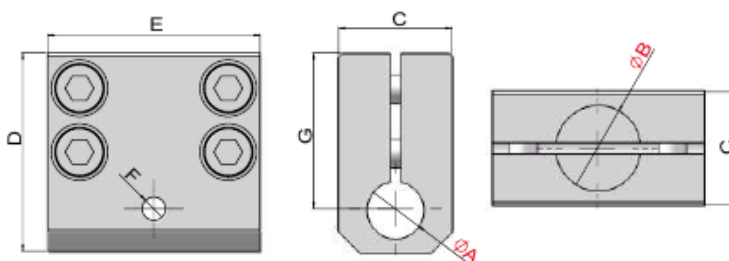

货号(PN)	型号(Model)	A	B	C	D	E	F	G	重量(Weight)
7.Y00036	SMBF1-0808	Ø8	Ø8	12	28	26	M4	22	15g
7.Y00037	SMBF1-0812	Ø8	Ø12	16	28	30	M4	22	31g
7.Y00038	SMBF1-1208	Ø12	Ø8	16	35	30	M4	25	29g
7.Y00003	SMBF1-1212	Ø12	Ø12	16	35	30	M4	25	26g
7.Y00039	SMBF1-1220	Ø12	Ø20	25	44	45	M4	34	88g
7.Y00040	SMBF1-2012	Ø20	Ø12	25	54	45	M4	39	111g
7.Y00041	SMBF1-2020	Ø20	Ø20	25	51.5	45	M4	39	78g

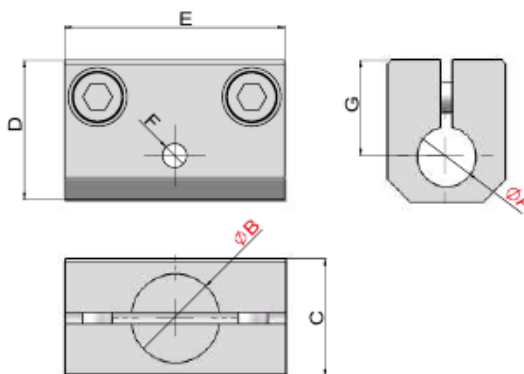

货号(PN)	型号(Model)	A	B	C	D	E	F	G	重量(Weight)
7.Y00029	SMBF-0808	Ø8	Ø8	12	20	30	M4	14	14g
7.Y00030	SMBF-0812	Ø8	Ø12	16	20	30	M4	14	23g
7.Y00031	SMBF-1208	Ø12	Ø8	16	26	30	M4	16	19g
7.Y00032	SMBF-1212	Ø12	Ø12	16	26	30	M4	16	18g
7.Y00033	SMBF-1220	Ø12	Ø20	25	30	45	M4	20	60g
7.Y00034	SMBF-2012	Ø20	Ø12	25	40	45	M4	25	63g
7.Y00035	SMBF-2020	Ø20	Ø20	25	40	45	M4	25	56g

Profile- SUS Tube  
型材、钢管

Stents Module  
支架模组

Quick Changer  
快换

Grip Module  
夹具组件

Air Nipper  
气动剪刀

Vacuum Module  
真空组件

Accessory Components  
附件

## 十字连接块#2

### Swing Block#2

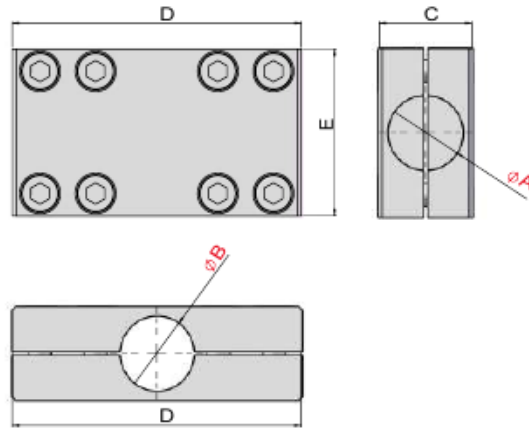

货号(PN)	型号(Model)	A	B	C	D	E	重量(Weight)
7.Y00047	SMBT3-2020	Ø20	Ø20	25	78	45	170g

## 吸力支架

### Suction Bracket

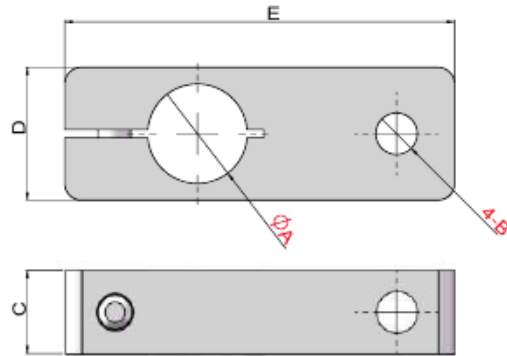

货号(PN)	型号(Model)	A	B	C	D	E	重量(Weight)
7.Y00057	SMBG1-8M5	Ø8	M5	12	12	33	9g
7.Y00058	SMBG1-8M6	Ø8	M6	10	12	33	9g
7.Y00059	SMBG1-12M5	Ø12	M5	10	16	47	16g
7.Y00060	SMBG1-12M6	Ø12	M6	10	16	47	16g
7.Y00061	SMBG1-12G18	Ø12	G1/8	16	16	47	25g



Profile、SUS Tube  
型材、钢管

Stentis Module  
支架模组

Quick Changer  
快换

Grip Module  
夹具组件

Air Nipper  
气动剪刀

Vacuum Module  
真空组件

Accessory Components  
附件

# 传感器支架

Sensor Bracket

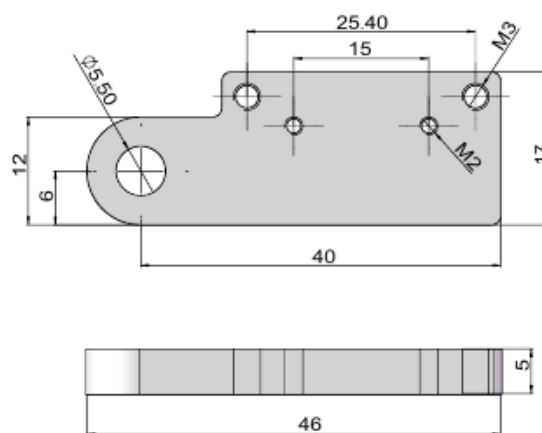

货号(PN)	型号(Model)	重量(Weight)
7.Y00070	SMBJ1-5	9g

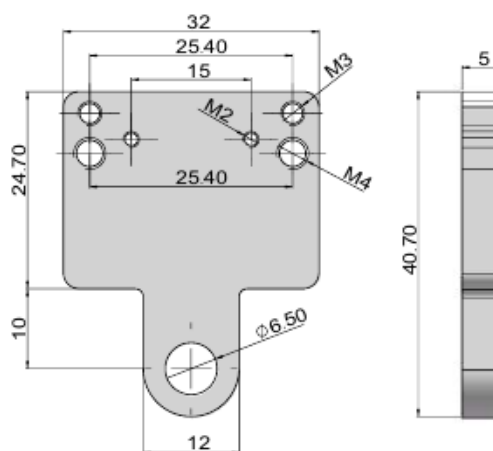

货号(PN)	型号(Model)	重量(Weight)
7.Y00071	SMBJ2-6	12g

Profile、SUS Tube  
型材、钢管

Stents Module  
支架模组

Quick Changer  
快换

Grip Module  
夹具组件

Air Nipper  
气动剪刀

Vacuum Module  
真空组件

Accessory Components  
附件

## 夹具支架 Chuck Bracket

Profile, SUS Tube  
型材、钢管

Stentis Module  
支架模组

Quick Changer  
快换

Grip Module  
夹具组件

Air Nipper  
气动剪刀

Vacuum Module  
真空组件

Accessory Components  
附件

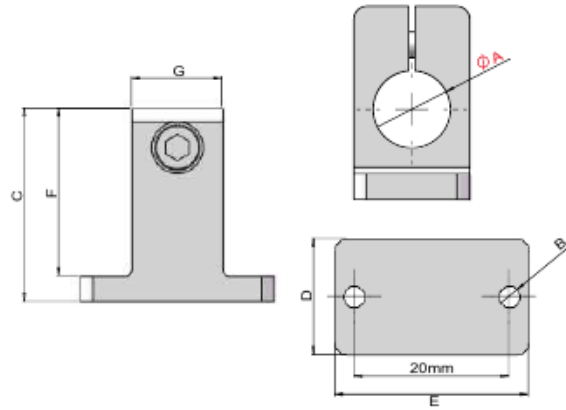

货号(PN)	型号(Model)	A	B	C	D	E	F	G	重量(Weight)
7.Y00072	SMBT5-8	$\phi 8$	M4	25	12	27	22	12	10g
7.Y00073	SMBT5-12	$\phi 12$	M4	30	18	30	26	14	19g

## 支架 Bracket

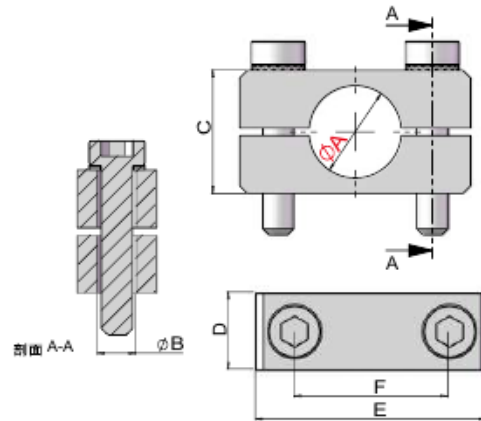

货号(PN)	型号(Model)	A	B	C	D	E	F	重量(Weight)
7.Y00074	SMBT6-12	$\phi 12$	$\phi 6.5$	16	16	40	30	35g

# 气爪安装支架

## Gripper Installation Bracket

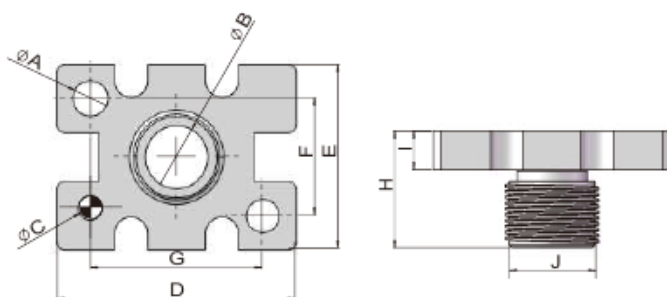

货号(PN)	型号(Model)	A	B	C	D	E	F	G	H	I	J	重量(Weight)
7.Y00740	SMBM-10	Ø3.2	Ø5	Ø2	23	16.4	12	18	14	4	M10*1	5g
7.Y00741	SMBM-16	Ø4.2	Ø6.5	Ø3	30.6	23.6	15	22	15	5	M12*1	10g
7.Y00728	SMBM-20	Ø5.5	Ø6.5	Ø4	42	27.6	18	32	15	5	M12*1	14g
7.Y00739	SMBM-25	Ø6.5	Ø10	Ø5	52	33.6	22	40	18	6	M17*1	27g
7.Y00738	SMBM-32	Ø6.5	Ø10	Ø5	60	40	26	46	18	6	M17*1	36g
7.Y00737	SMBM-40	Ø8.5	Ø16	Ø5	72	48	32	56	20	8	M27*1	67g



Profile- SUS Tube  
型材、钢管

Stents Module  
支架模组

Quick Changer  
快换

Grip Module  
夹具组件

Air Nipper  
气动剪刀

Vacuum Module  
真空组件

Accessory Components  
附件

# 支架T

## Bracket T

Profile、SUS Tube  
型材、钢管

Stents Module  
支架模组

Quick Changer  
快换

Grip Module  
夹具组件

Air Nipper  
气动剪刀

Vacuum Module  
真空组件

Accessory Components  
附件

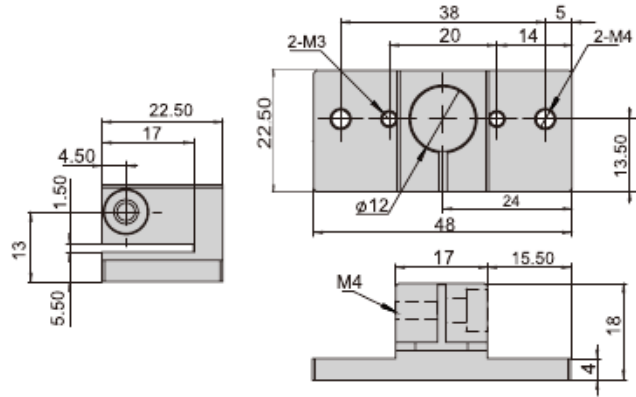

货号(PN)	型号(Model)	重量(Weight)
7.Y00082	SMBU-12	21g

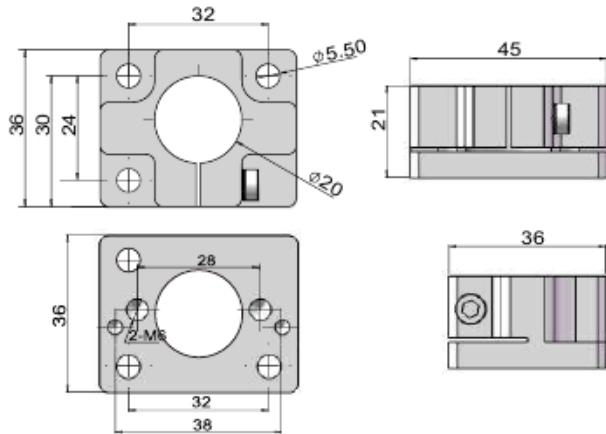

货号(PN)	型号(Model)	重量(Weight)
7.Y00255	SMBU2-20	49g

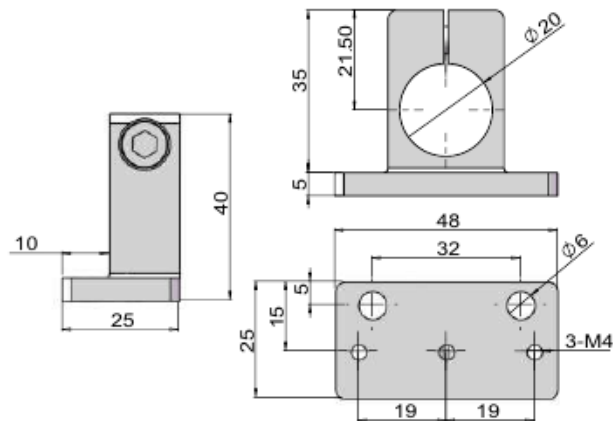

货号(PN)	型号(Model)	重量(Weight)
7.Y00090	SMBU8-20	39g

# 支架TH

## Bracket TH

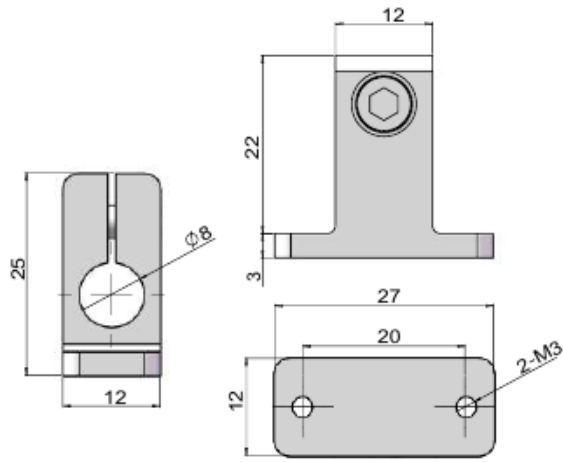

货号(PN)	型号(Model)	重量(Weight)
7.Y00085	SMBU3-8	10g

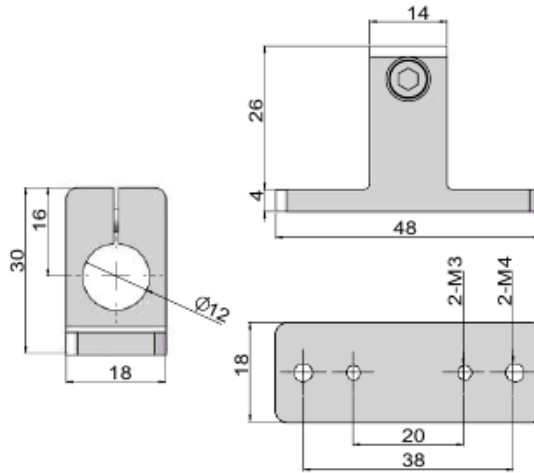

货号(PN)	型号(Model)	重量(Weight)
7.Y00086	SMBU4-12	22g

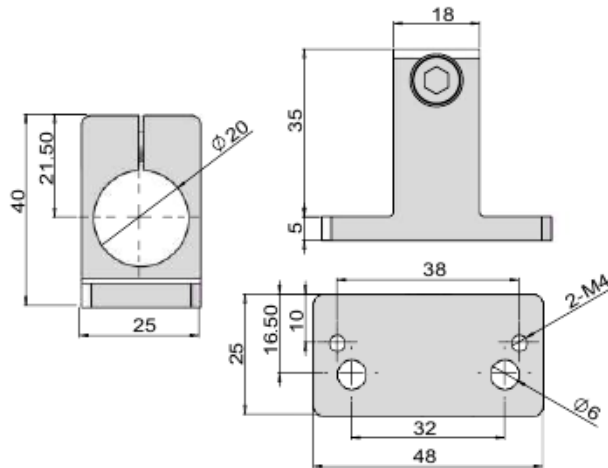

货号(PN)	型号(Model)	重量(Weight)
7.Y00087	SMBU5-20	44g

Profile、SUS Tube  
型材、钢管

Stents Module  
支架模组

Quick Changer  
快换

Grip Module  
夹具组件

Air Nipper  
气动剪刀

Vacuum Module  
真空组件

Accessory Components  
附件

## 支架TV

### Bracket TV

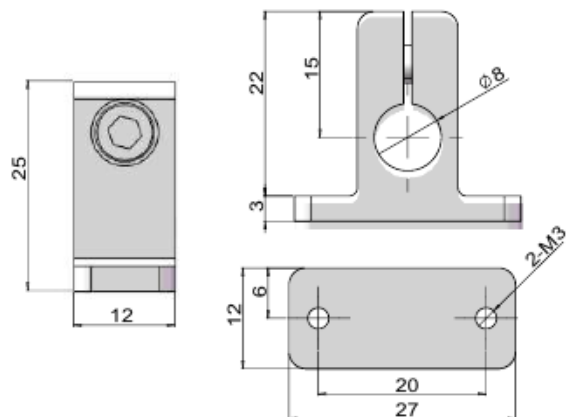

货号(PN)	型号(Model)	重量(Weight)
7.Y00088	SMBU6-8	10g

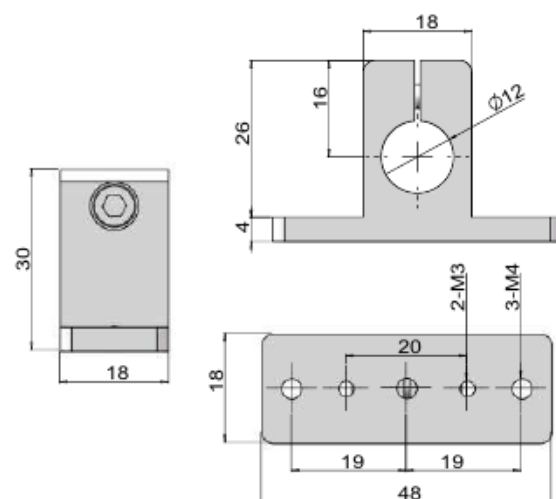

货号(PN)	型号(Model)	重量(Weight)
7.Y00089	SMBU7-12	26g

## 支架L12

### Bracket L12

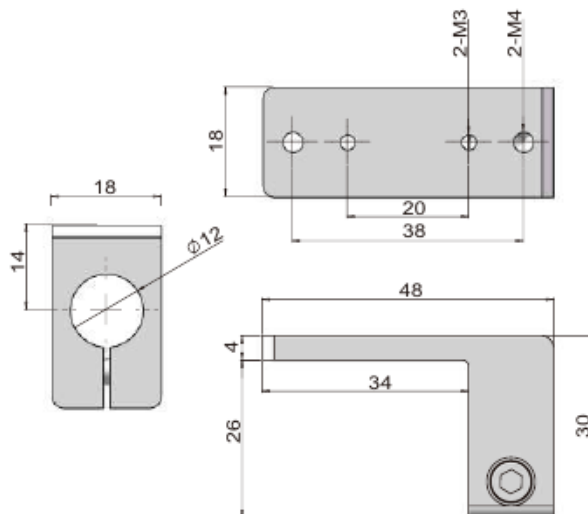

货号(PN)	型号(Model)	重量(Weight)
7.Y00081	SMBT9-12	23g

## 支架 Bracket

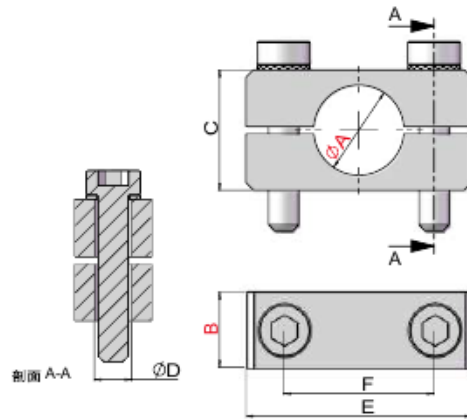

货号(PN)	型号(Model)	A	B	C	D	E	F	重量(Weight)
7.Y00091	SMBK1-8T10	Ø8	10	16	Ø5.5	30	20	20g
7.Y00092	SMBK1-12T10	Ø12	10	16	Ø5.5	30	20	14g
7.Y00093	SMBK1-20T10	Ø20	10	27	Ø6.5	40	30	36g
7.Y00094	SMBK1-8T16	Ø8	16	16	Ø6.5	30	20	32g
7.Y00095	SMBK1-12T16	Ø12	16	16	Ø4.5	30	20	20g
7.Y00096	SMBK1-20T16	Ø20	16	27	Ø6.5	40	30	48g

## 固定支架 Fixed Bracket

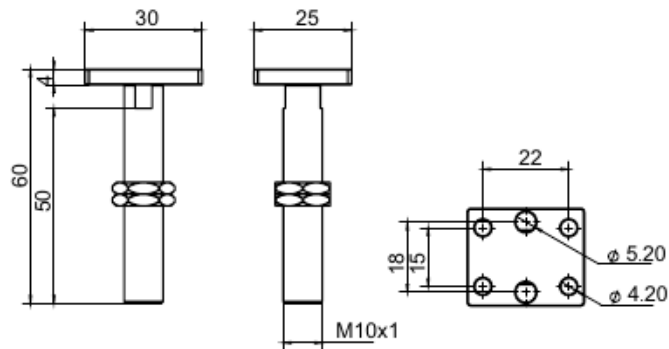

货号(PN)	型号(Model)	重量(Weight)
7.Y01051	SMBU9-M10	21g



Profile- SUS Tube  
型材、钢管

Stents Module  
支架模组

Quick Changer  
快换

Grip Module  
夹具组件

Air Nipper  
气动剪刀

Vacuum Module  
真空组件

Accessory Components  
附件

## 滑移支架 Slide Bracket

Profile, SUS Tube  
型材、钢管

Stents Module  
支架模组

Quick Changer  
快换

Grip Module  
夹具组件

Air Ripper  
气动剪刀

Vacuum Module  
真空组件

Accessory Components  
附件

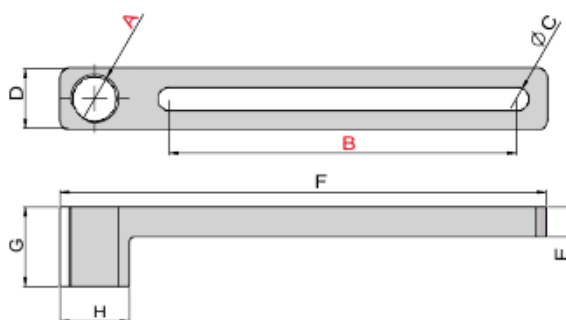

货号(PN)	型号(Model)	A	B	C	D	E	F	G	H	重量(Weight)
7.Y00115	SCF1-40M3	M3	40	4.5	12	5	56	10	8	7g
7.Y00118	SCF1-40G18	G1/8	40	4.5	12	6	68	16	14	12g
7.Y00129	SCF1-70M3	M3	70	4.5	12	5	86	10	8	10g
7.Y00132	SCF1-70G18	G1/8	70	4.5	12	6	98	16	14	15g

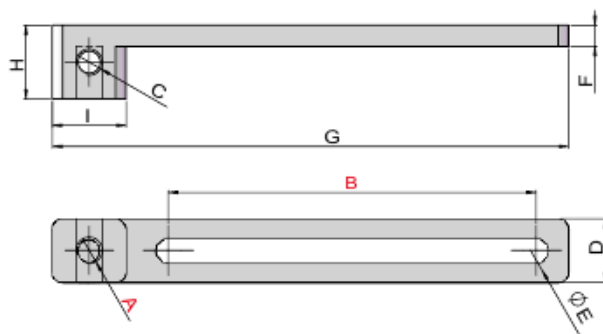

货号(PN)	型号(Model)	A	B	C	D	E	F	G	H	I	重量(Weight)
7.Y00173	SCF2-40M5	M5	40	M5	12	4.5	4	68	14	14	9g
7.Y00117	SCF2-40M6	M6	40	M6	12	4.5	4	68	14	14	10g
7.Y00130	SCF2-70M5	M5	70	M5	12	4.5	4	98	14	14	12g
7.Y00131	SCF2-70M6	M6	70	M6	12	4.5	4	98	14	14	13g

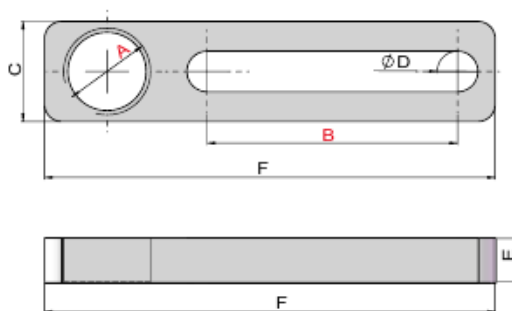

货号(PN)	型号(Model)	A	B	C	D	E	F	重量(Weight)
7.Y00119	SCF3-40M10	M10*1	40	16	6.5	5	70	10g
7.Y00120	SCF3-40M12	M12*1	40	16	6.5	5	72	10g
7.Y00121	SCF3-40M17	M17*1	40	25	6.5	5	80	20g
7.Y00133	SCF3-70M10	M10*1	70	16	6.5	5	100	14g
7.Y00134	SCF3-70M12	M12*1	70	16	6.5	5	102	14g
7.Y00135	SCF3-70M17	M17*1	70	25	6.5	5	110	28g

# 滑移支架

## Slide Bracket

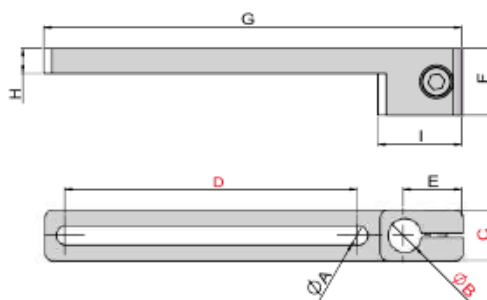

货号(PN)	型号(Model)	A	B	C	D	E	F	G	H	I	重量(Weight)
7.Y00122	SCF4-0840W12	4.5	Ø8	12	40	14	16	70	6	20	14g
7.Y00123	SCF4-0840W16	6.5	Ø8	16	40	14	16	70	6	20	20g
7.Y00004	SCF4-1240W16	6.5	Ø12	16	40	16	16	75	6	25	21g
7.Y00124	SCF4-2040W25	6.5	Ø20	25	40	20	16	86	6	34	39g
7.Y00136	SCF4-0870W12	4.5	Ø8	12	70	14	16	100	6	20	18g
7.Y00137	SCF4-0870W16	6.5	Ø8	16	70	14	16	100	6	20	25g
7.Y00138	SCF4-1270W16	6.5	Ø12	16	70	16	16	105	6	25	25g
7.Y00139	SCF4-2070W25	6.5	Ø20	25	70	20	16	116	6	34	49g

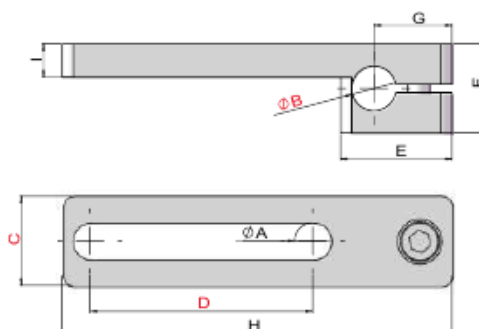
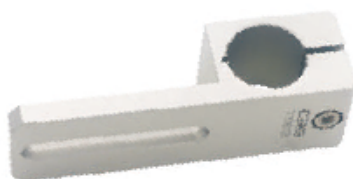

货号(PN)	型号(Model)	A	B	C	D	E	F	G	H	I	重量(Weight)
7.Y00125	SCF5-0840W16	6.5	Ø8	16	40	20	16	14	70	6	20g
7.Y00126	SCF5-0840W12	4.5	Ø8	12	40	20	16	14	70	6	15g
7.Y00127	SCF5-1240W16	6.5	Ø12	16	40	25	16	16	75	6	20g
7.Y00128	SCF5-2040W25	6.5	Ø20	25	40	34	25	20	86	6	53g
7.Y00140	SCF5-0870W16	6.5	Ø8	16	70	20	16	14	100	6	25g
7.Y00141	SCF5-0870W12	4.5	Ø8	12	70	20	16	14	100	6	19g
7.Y00142	SCF5-1270W16	6.5	Ø12	16	70	25	16	16	105	6	25g
7.Y00143	SCF5-2070W25	6.5	Ø20	25	70	34	25	20	116	6	48g

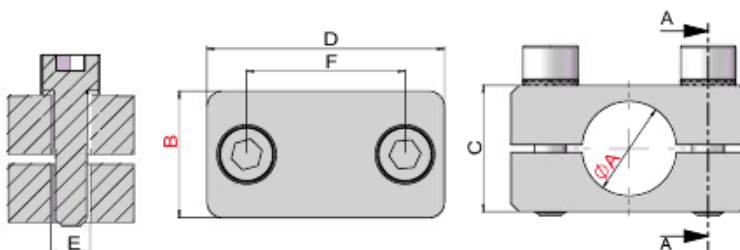

货号(PN)	型号(Model)	A	B	C	D	E	F	重量(Weight)
7.Y00064	SMBS-8T10	Ø8	10	16	30	M4	20	16g
7.Y00065	SMBS-12T10	Ø12	10	16	30	M4	20	15g
7.Y00066	SMBS-20T10	Ø20	10	25	40	M6	30	33g
7.Y00067	SMBS-8T16	Ø8	16	16	30	M6	20	29g
7.Y00001	SMBS-12T16	Ø12	16	16	30	M6	20	29g
7.Y00068	SMBS-20T16	Ø20	16	25	40	M6	30	44g

Profile- SUS Tube  
型材、钢管

Stents Module  
支架模组

Quick Changer  
快换

Grip Module  
夹具组件

Air Nipper  
气动剪刀

Vacuum Module  
真空组件

Accessory Components  
附件

# 旋转支架

## Rotation Bracket

Profile, SUS Tube  
型材、钢管

Stents Module  
支架模组

Quick Changer  
快换

Grip Module  
夹具组件

Air Nipper  
气动剪刀

Vacuum Module  
真空组件

Accessory Components  
附件

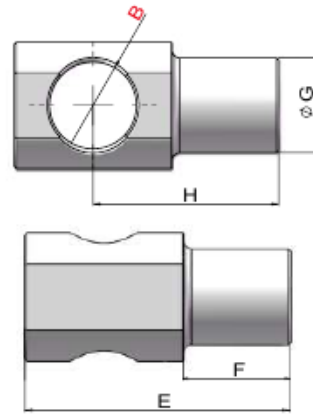
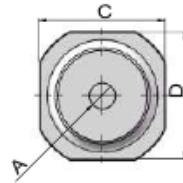

货号(PN)	型号(Model)	A	B	C	D	E	F	G	H	重量(Weight)
7.Y00099	SMBR2-M10	M4	M10	14	14	26.5	11.5	Ø8	19	6g
7.Y00100	SMBR2-M12	M4	M12	16	16	33.5	13.5	Ø12	23.5	12g

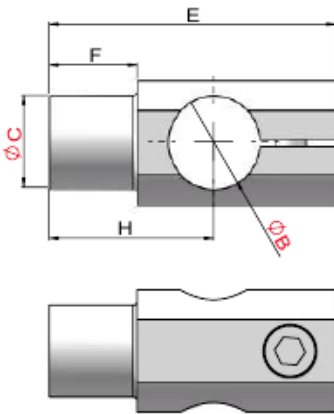
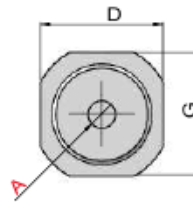

货号(PN)	型号(Model)	A	B	C	D	E	F	G	H	重量(Weight)
7.Y00103	SMBR4-0808M4	M4	Ø8	Ø8	12	32.5	11.5	12	17.5	7g
7.Y00110	SMBR4-1208M4	M4	Ø12	Ø8	16	37.5	11.5	16	21.5	13g
7.Y00019	SMBR4-1212M4	M4	Ø12	Ø12	16	39.5	13.5	16	23.5	15g
7.Y00268	SMBR4-1212M4L	M4	Ø12	Ø12	16	55	29	16	39	20g
7.Y00461	SMBR4-1420M6	M6	Ø14	Ø20	25	60	20	25	37	70g
7.Y00007	SMBR4-2020M6	M6	Ø20	Ø20	25	60	20	25	37	59g
7.Y00206	SMBR4-2020M6L	M6	Ø20	Ø20	25	85	45	25	62	81g

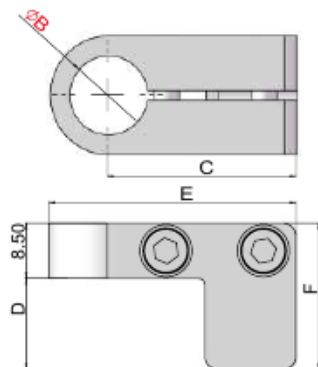
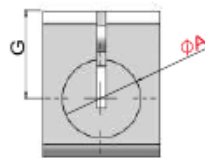

货号(PN)	型号(Model)	A	B	C	D	E	F	G	重量(Weight)
7.Y00111	SMBR5-1208	Ø12	Ø8	29	14	38	22.5	13.5	24g
7.Y00104	SMBR5-0808	Ø8	Ø8	29	11.5	36	20	13	16g
7.Y00112	SMBR5-1212	Ø12	Ø12	29	14	38	22.5	13.5	18g

# 旋转支架

## Rotation Bracket

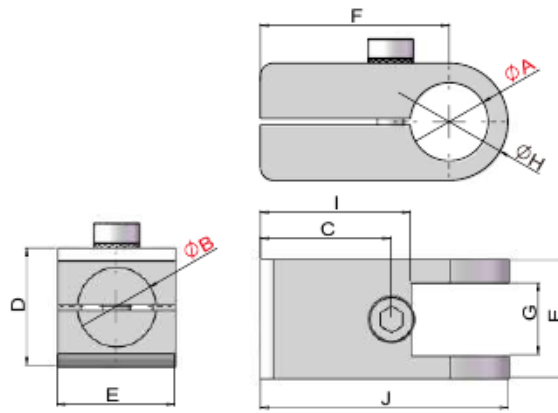

货号(PN)	型号(Model)	A	B	C	D	E	F	G	H	I	J	重量(Weight)
7.Y00113	SMBR7-0808	Ø8	Ø8	16	15	15	25	10	15	21	32.5	13g
7.Y00114	SMBR7-1212	Ø12	Ø12	20	18	18	29	11	18	23	38	18g

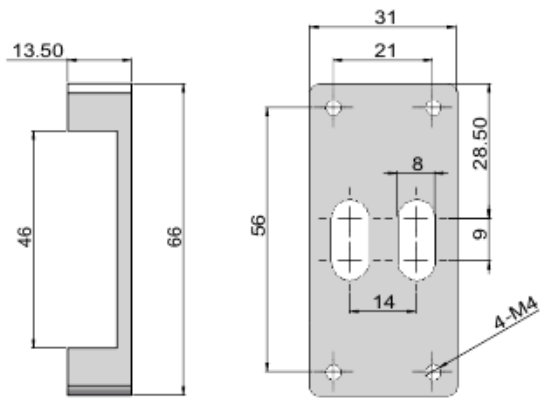

货号(PN)	型号(Model)	重量(Weight)
7.Y00063	SMBR-46	31g

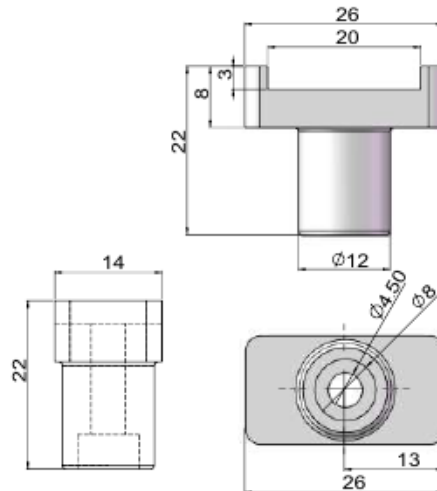

货号(PN)	型号(Model)	重量(Weight)
7.Y00098	SMBR1-12	9g

Profile- SUS Tube  
型材、钢管

Stents Module  
支架模组

Quick Changer  
快换

Grip Module  
夹具组件

Air Nipper  
气动剪刀

Vacuum Module  
真空组件

Accessory Components  
附件

# 旋转支撑

## Swivelling Support

Profile, SUS Tube  
型材、钢管

Stents Module  
支架模组

Quick Changer  
快换

Grip Module  
夹具组件

Air Nipper  
气动剪刀

Vacuum Module  
真空组件

Accessory Components  
附件

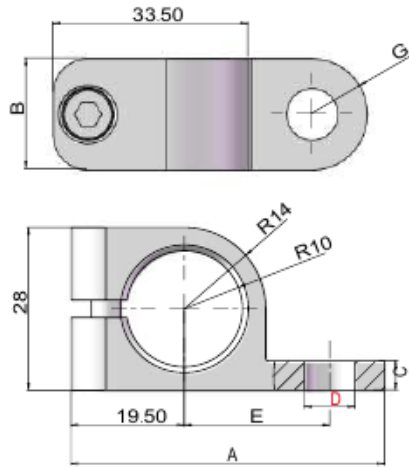

货号(PN)	7.Y00236	7.Y00234
规格(Spec)	SCC-20G18	SCC-20M16
A(mm)	54	60.5
B(mm)	19	24
C(mm)	5	6
D(mm)	G1/8	M16×1
E(mm)	25	29
G(mm)	R9.5	R12
重量(Weight)	30g	40g



# 吸盘固定支架

Direct Connector For Vacuum Cup



(螺钉套件选配) (Kit With Screws Option)

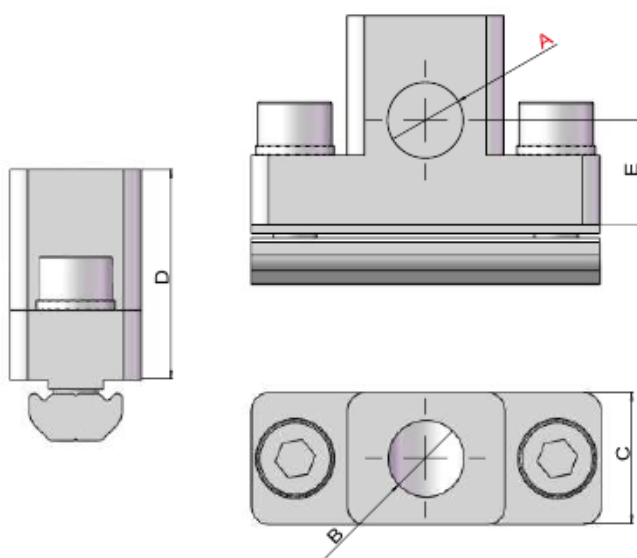

货号(PN)	7.Y00235	7.Y00237
型号(Model)	SVA-G18	SVA-G14
A(mm)	G1/8	G1/4
B(mm)	G1/8	G1/8
C(mm)	15	15
D(mm)	24	24
E(mm)	12	10
PEP2518	√	√
PEP2525	√	√
PEP5025	√	√
PEP4040	√	√
PEP3030	√	√
螺钉选配件 Accessorier selection		
螺丝(Screws)	PTC-M5L16*2	PTC-M5L16*2
双齿平垫(Single hole shim)	PTS-M5*2	PTS-M5*2
T型螺母(T-Nuts)	PTN-M5P30*1	PTN-M5P30*1
总重量(Weight)	42g	40g

注: 如需螺钉套件货号 and 型号加 T 如: 型号 SVA-G18T 货号 7.Y00235-T

Note: If screw kits needed, add T to the part number and model number. eg: Model SVA-G18T Part number 7.Y00235-T



Profile- SUS Tube  
型材、钢管

Stents Module  
支架模组

Quick Changer  
快换

Grip Module  
夹具组件

Air Nipper  
气动剪刀

Vacuum Module  
真空组件

Accessory Components  
附件

# 吸盘固定支架

## Direct Connector For Vacuum Cup

Profile, SUS Tube  
型材、钢管

Stents Module  
支架模组

Quick Changer  
快换

Grip Module  
夹具组件

Air Nipper  
气动剪刀

Vacuum Module  
真空组件

Accessory Components  
附件

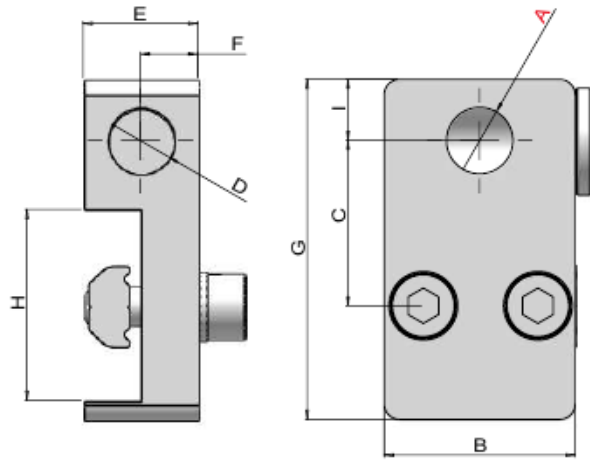

(螺钉套件选配) (Kit With Screws Option)

货号(PN)	7.Y00242	7.Y00244	7.Y00243
型号(Model)	SVB-M5	SVB-G18	SVB-G14
A(mm)	M5	G1/8	G1/4
B(mm)	16	25	25
C(mm)	13.5	21.5	21.5
D(mm)	M5	G1/8	G1/8
E(mm)	8	15	15
F(mm)	4	7.5	7.5
G(mm)	29	44.5	46.5
H(mm)	18	25	25
I (mm)	4.3	8	10
PEP2518	-	√	√
PEP2525	-	√	√
PEP5025	-	√	√
<b>螺钉选配件 Accessorier selection</b>			
螺丝(Screws)	PTC-M4L12*2	PTC-M5L16*2	PTC-M5L16*2
双齿平垫(Single hole shim)	PTS-M4*2	PTS-M5*2	PTS-M5*2
T型螺母(T-Nuts)	PTN-M4P8*1	PTN-M5P15*1	PTN-M5P15*1
总重量(Weight)	15g	45g	45g

注: 如需螺钉套件货号 and 型号加T 如: 型号SVB-M5T 货号7.Y00242-T

Note: If screw kits needed, add T to the part number and model number. eg: Model SVB-M5T Part number 7.Y00242-T



# 吸盘加长固定支架

## Mounting Bracket For Vacuum Cup



(螺钉套件选配) (Kit With Screws Option)

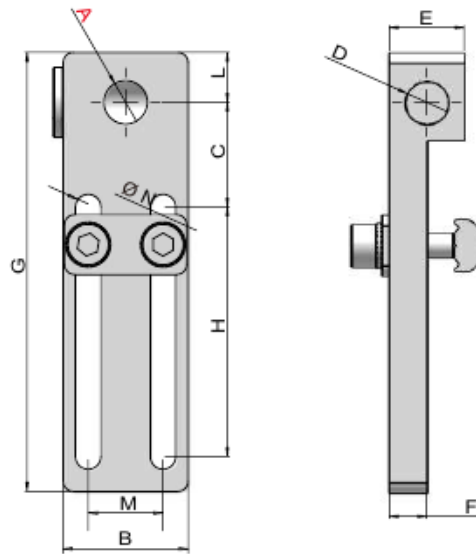

货号(PN)	7.Y00328	7.Y00238	7.Y00239
型号(Model)	SVC-M5	SVC-G18	SVC-G14
A(mm)	M5	G1/8	G1/4
B(mm)	16	25	25
C(mm)	14	21	21
D(mm)	M5	G1/8	G1/8
E(mm)	8	15	15
F(mm)	4	7.5	7.5
G(mm)	65	88	88
H(mm)	40	50	50
L(mm)	6	10	10
M(mm)	8	15	15
N(mm)	Ø4.2	Ø5.2	Ø5.2
PEP2518	√	√	√
PEP2525	√	√	√
PEP5025	√	√	√
PEP4040	-	√	√
PEP3030	√	√	√
<b>螺钉选配件 Accessorier selection</b>			
螺丝(Screws)	PTC-M4L14*2	PTC-M5L16*2	PTC-M5L16*2
双齿平垫(Single hole shim)	PTS-M4*2	PTS-M5*2	PTS-M5*2
T型螺母(T-Nuts)	PTN-M4P8*1	PTN-M5P15*1	PTN-M5P15*1
双孔平垫(Double holes shim)	PTD-M4P8*1	PTD-M5P15*1	PTD-M5P15*1
总重量(Weight)	20g	60g	60g

注: 如需螺钉套件货号 and 型号加 T 如: 型号 SVC-M5T 货号 7.Y00328-T

Note: If screw kits needed, add T to the part number and model number. eg: Model SVC-M5T Part number 7.Y00328-T



Profile- SUS Tube  
型材、钢管

Stents Module  
支架模组

Quick Changer  
快换

Grip Module  
夹具组件

Air Nipper  
气动剪刀

Vacuum Module  
真空组件

Accessory Components  
附件

# 可旋转吸盘固定支架

## Mounting Bracket For Vacuum Cup

Profile, SUS Tube  
型材、钢管

Stents Module  
支架模组

Quick Changer  
快换

Grip Module  
夹具组件

Air Ripper  
气动剥刀

Vacuum Module  
真空组件

Accessory Components  
附件



(螺钉套件选配) (Kit With Screws Option)

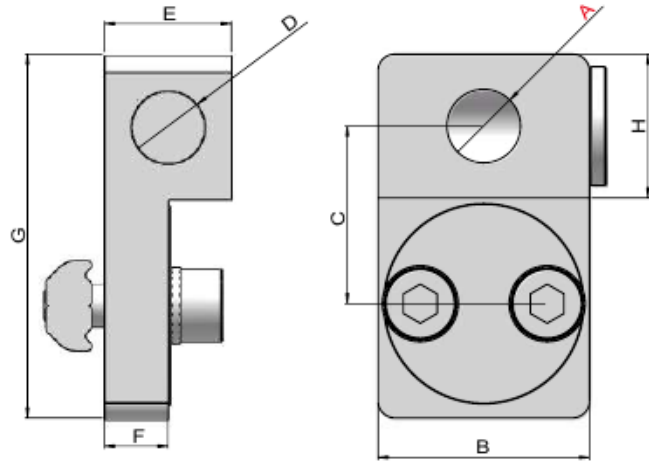

货号(PN)	7.Y00416	7.Y00417	7.Y00418
型号(Model)	SVD-M5	SVD-G18	SVD-G14
A(mm)	M5	G1/8	G1/4
B(mm)	16	25	25
C(mm)	13	21	21
D(mm)	M5	G1/8	G1/8
E(mm)	10	15	15
F(mm)	5	7.5	7.5
G(mm)	28	43	43
H(mm)	10	17	17
PEP2518	√	√	√
PEP2525	√	√	√
PEP5025	√	√	√
PEP4040	-	√	√
PEP3030	√	√	√
螺钉选配件 Accessorier selection			
螺丝(Screws)	PTC-M4L12*2	PTC-M5L16*2	PTC-M5L16*2
双齿平垫(Single hole shim)	PTS-M4*2	PTS-M5*2	PTS-M5*2
T型螺母(T-Nuts)	PTN-M4P8*1	PTN-M5P15*1	PTN-M5P15*1
总重量(Weight)	15g	45g	42g

注: 如需螺钉套件货号和型号加T 如: 型号SVD-M5T 货号7.Y00416-T

Note: If screw kits needed, add T to the part number and model number. eg: Model SVD-M5T Part number 7.Y00416-T

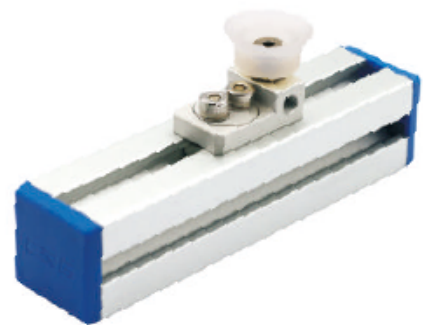

# 吸盘安装杆

Leg For Vacuum Cup

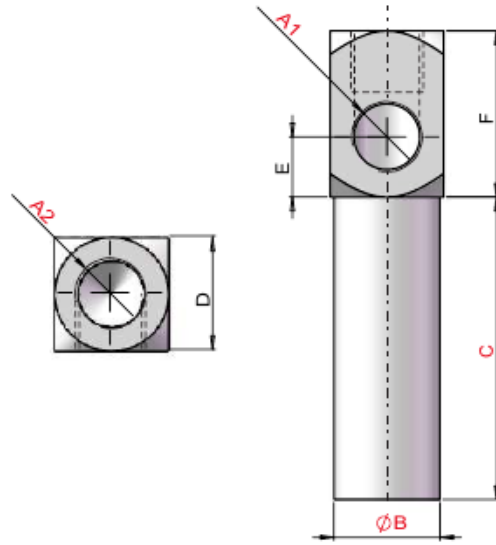

货号 (PN)	型号 (Model)	A1(mm)	A2(mm)	B(mm)	C(mm)	D(mm)	E(mm)	F(mm)	重量 (Weight)
7.Y00410	SVE-M51030	M5	M5	Ø10	30	11	6	16	10g
7.Y00411	SVE-M51060	M5	M5	Ø10	60	11	6	16	13g
7.Y00412	SVE-M51090	M5	M5	Ø10	90	11	6	16	17g
7.Y00772	SVE-M51230	M5	M5	Ø12	30	13	7	17	12g
7.Y00773	SVE-M51260	M5	M5	Ø12	60	13	7	17	15g
7.Y00774	SVE-M51290	M5	M5	Ø12	90	13	7	17	19g
7.Y00413	SVE-G181440	G1/8	G1/8	Ø14	40	15	8	22	17g
7.Y00414	SVE-G181480	G1/8	G1/8	Ø14	80	15	8	22	25g
7.Y00415	SVE-G1814120	G1/8	G1/8	Ø14	120	15	8	22	32g
7.Y00008	SVE-G142050	G1/8	G1/4	Ø20	50	20	8	23	40g
7.Y00009	SVE-G1420100	G1/8	G1/4	Ø20	100	20	8	23	60g
7.Y00010	SVE-G1420150	G1/8	G1/4	Ø20	150	20	8	23	75g

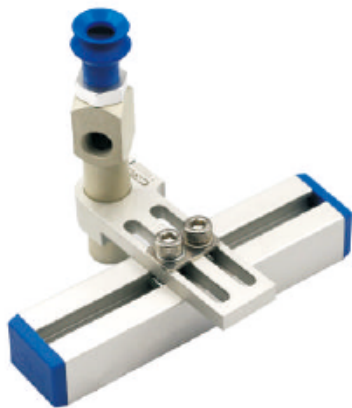

Profile- SUS Tube  
型材、钢管

Stents Module  
支架模组

Quick Changer  
快换

Grip Module  
夹具组件

Air Nipper  
气动剪刀

Vacuum Module  
真空组件

Accessory Components  
附件

# 夹腿

## Clamp Leg

Profile, SUS Tube  
型材、钢管

Stents Module  
支架模组

Quick Changer  
快换

Grip Module  
夹具组件

Air Nipper  
气动剪刀

Vacuum Module  
真空组件

Accessory Components  
附件



夹腿  
Clamp Leg  
(SCA1)



重型夹腿  
Heavy Clamp Leg  
(SCA2)

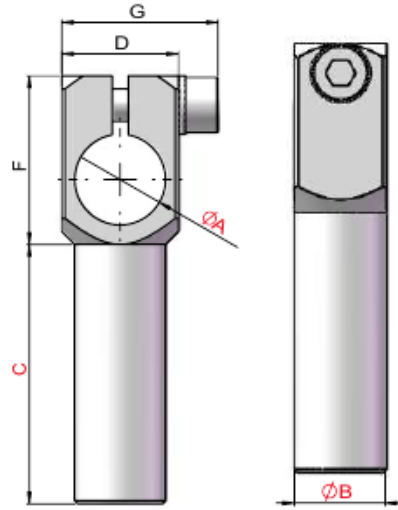

货号(PN)	型号(Model)	A(mm)	B(mm)	C(mm)	D(mm)	F(mm)	G(mm)	重量(Weight)
7.Y00398	SCA1-1010L30	Ø10	Ø10	30	14	19	19	10g
7.Y00399	SCA1-1010L60	Ø10	Ø10	60	14	19	19	15g
7.Y00400	SCA1-1010L90	Ø10	Ø10	90	14	19	19	20g
7.Y00769	SCA1-1212L30	Ø12	Ø12	30	19	21	21	13g
7.Y00770	SCA1-1212L60	Ø12	Ø12	60	19	21	21	18g
7.Y00771	SCA1-1212L90	Ø12	Ø12	90	19	21	21	23g
7.Y00401	SCA1-1414L40	Ø14	Ø14	40	18	26	24	20g
7.Y00402	SCA1-1414L80	Ø14	Ø14	80	18	26	24	30g
7.Y00403	SCA1-1414L120	Ø14	Ø14	120	18	26	24	40g
7.Y00404	SCA1-2020L50	Ø20	Ø20	50	25	32	31	45g
7.Y00405	SCA1-2020L100	Ø20	Ø20	100	25	32	31	70g
7.Y00406	SCA1-2020L150	Ø20	Ø20	150	25	32	31	105g
7.Y00407	SCA1-3030L80	Ø30	Ø30	80	40	44	46	170g
7.Y00408	SCA1-3030L140	Ø30	Ø30	140	40	44	46	230g
7.Y00409	SCA1-3030L200	Ø30	Ø30	200	40	44	46	300g
7.Y00996	SCA2-2020L50	Ø20	Ø20	50	25	32	31	65g
7.Y01000	SCA2-2020L100	Ø20	Ø20	100	25	32	31	86g
7.Y00997	SCA2-2020L150	Ø20	Ø20	150	25	32	31	101g
7.Y02030	SCA2-2525L50	Ø25	Ø25	50	30	38	36	102g
7.Y02031	SCA2-2525L100	Ø25	Ø25	100	30	38	36	131g
7.Y02032	SCA2-2525L150	Ø25	Ø25	150	30	38	36	163g
7.Y01006	SCA2-3030L80	Ø30	Ø30	80	35	43	42	209g
7.Y01005	SCA2-3030L140	Ø30	Ø30	140	35	43	42	288g
7.Y01001	SCA2-3030L200	Ø30	Ø30	200	35	43	42	344g



# NR剪刀固定支架

## NR Nipper Mounting Bracket

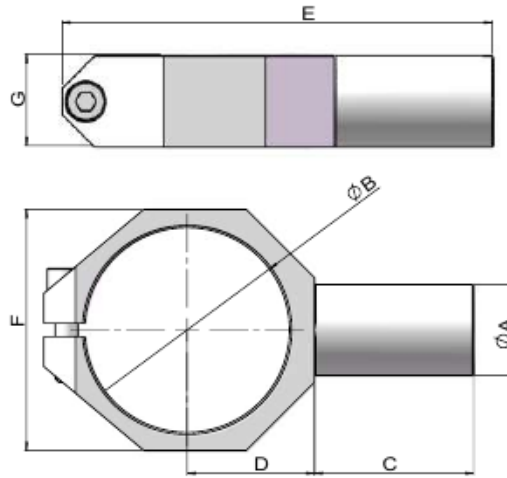

货号(PN)	7.Y00470	7.Y00331	7.Y00261	7.Y00742
型号(Model)	SCE-NR10	SCE-NR20	SCE-NR30	SCE-NR50
A(mm)	Ø14	Ø20	Ø20	Ø30
B(mm)	Ø36	Ø45	Ø56	Ø75
C(mm)	255	35	40	48
D(mm)	22	28	33	41
E(mm)	72	94.5	111	138
F(mm)	43	53	65	83
G(mm)	15	20	25	40
重量(Weight)	29.7g	65g	110g	308g



Profile-  
SUSTube  
型材、钢管

Stents Module  
支架模组

Quick  
Changer  
快换

Grip  
Module  
夹具组件

Air  
Nipper  
气动剪刀

Vacuum  
Module  
真空组件

Accessory  
Components  
附件

# NS剪刀固定支架

## NS Nipper Mounting Bracket

Profile, SUS Tube  
型材、钢管

Stentis Module  
支架模组

Quick Changer  
快换

Grip Module  
夹具组件

Air Nipper  
气动剪刀

Vacuum Module  
真空组件

Accessory Components  
附件

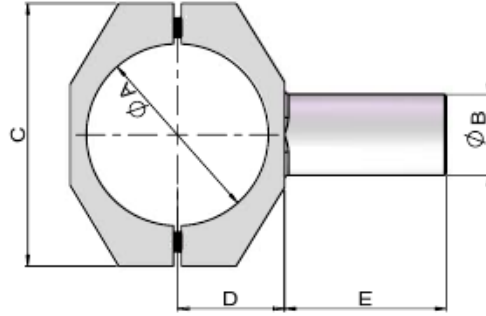
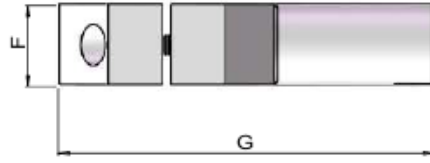

货号(PN)	7.Y00692	7.Y00693
型号(Model)	SCE1-NS20	SCE1-NS30
A(mm)	Ø45	Ø56
B(mm)	Ø20	Ø20
C(mm)	65	76
D(mm)	27	33
E(mm)	40	40
F(mm)	20	25
G(mm)	94	106
重量(Weight)	111g	123g



## NY05剪刀固定块

NY05 Fixing Block

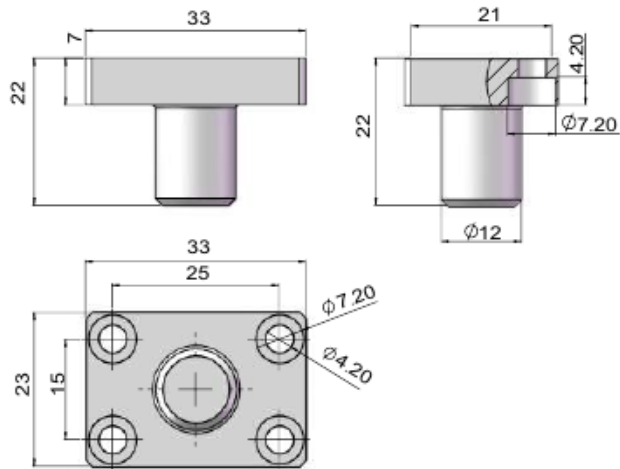

货号(PN)	型号(Model)	重量(Weight)
7.Y00796	SCE2-05	17g

## NY10/NY15 剪刀固定块

NY10/NY15 Fixing Block

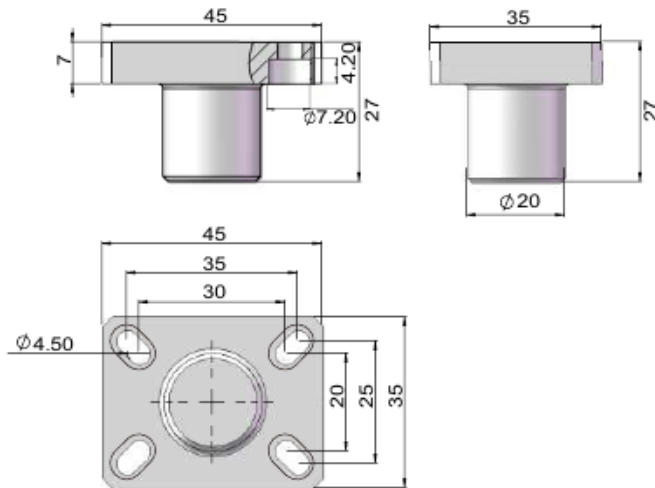

货号(PN)	型号(Model)	重量(Weight)
1.Y00094	SCE2-1015	38g



Profile、SUS Tube

Stents Module

Quick Changer

Grip Module

Air Nipper

Vacuum Module

Accessory Components

## NY25剪刀固定块

NY25 Fixing Block

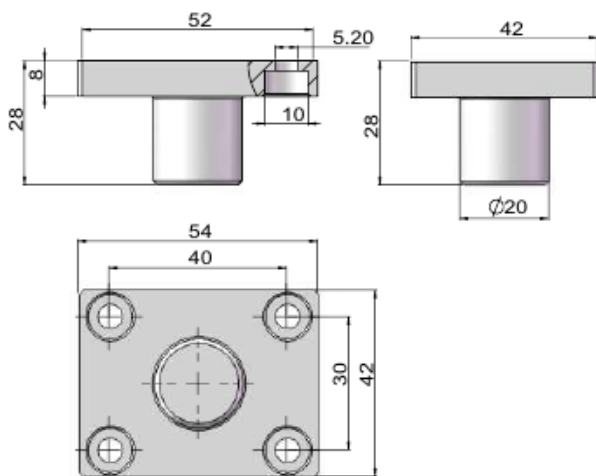

货号(PN)	型号(Model)	重量(Weight)
7.Y00633	SCE2-25	61g



## 剪刀固定支架

Nipper Bracket

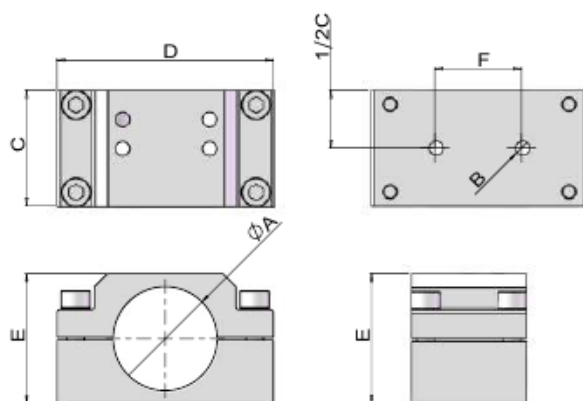

货号(PN)	型号(Model)	A	B	C	D	E	F	重量(Weight)
7.Y00075	SCE3-N10	$\phi 36$	M6	40	75	45	30	246g
7.Y00076	SCE3-N20	$\phi 45$	M6	40	75	53	30	228g
7.Y00077	SCE3-N30	$\phi 56$	M6	40	86	63	30	267g



## 气剪安装支架

Gas Cut Bracket

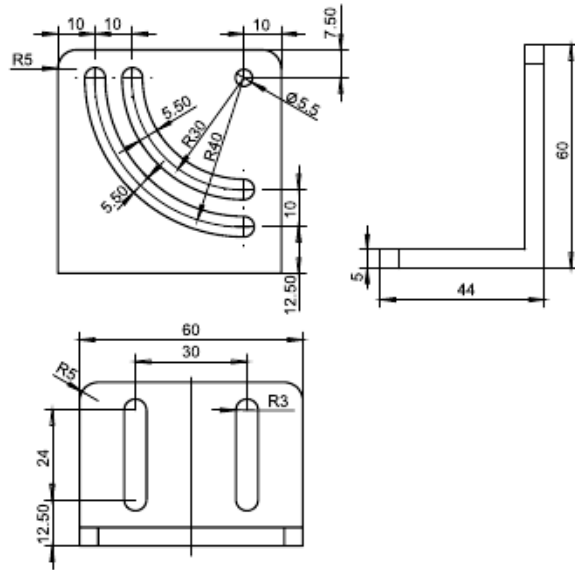
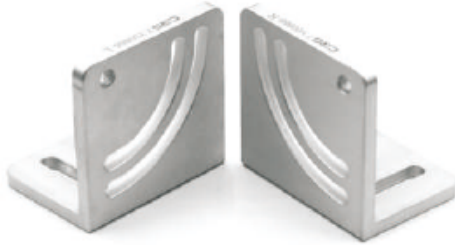

货号(PN)	7.Y00868
型号(Model)	SCE4-NR(L.R)

※L.R配对销售 L.R Use together

※GT-NR用 GT-N Use

※重量 Weight: 65.5g

## 气剪固定支架

Gas Cut fixation

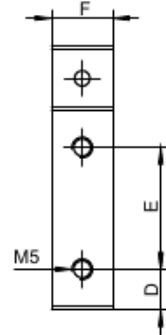
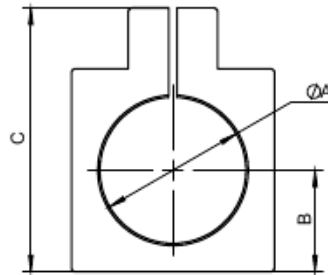

货号(PN)	型号(Model)	A	B	C	D	E	F	重量(Weight)
7.Y00146	SCE4-NR30	56	35	85	10	40	15	111g
7.Y00147	SCE4-NR20	45	30	75	10	40	15	93g
7.Y00148	SCE4-NR10	36	25	65	10	30	15	72g



Profile- SUS Tube  
型材、钢管

Stents Module  
支架模组

Quick Changer  
快换

Grip Module  
夹具组件

Air Nipper  
气动剪刀

Vacuum Module  
真空组件

Accessory Components  
附件

## 剪刀水口夹可旋转安装支架

### Adjustable Nipper Mounting Clamps

Profile, SUS Tube  
型材、钢管

Stents Module  
支架模组

Quick Changer  
快换

Grip Module  
夹具组件

Air Nipper  
气动剪刀

Vacuum Module  
真空组件

Accessory Components  
附件

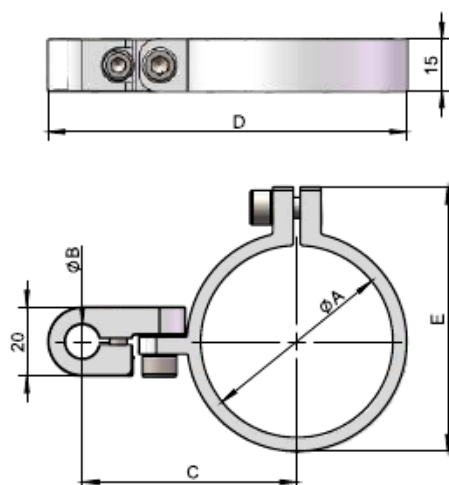

货号(PN)	型号(Model)	A	B	C	D	E	重量(Weight)
7.Y00946	SCE-NR20-D10	Ø45	Ø10	56.5	93	65	57.5g
7.Y00947	SCE-NR20-D12	Ø45	Ø12	56.5	93	65	55.5g
7.Y00948	SCE-NR30-D10	Ø56	Ø10	62.5	104.5	77	67.5g
7.Y00949	SCE-NR30-D12	Ø56	Ø12	62.5	104.5	77	65.5g



# 机械手固定支架

## Access Robot Bracket

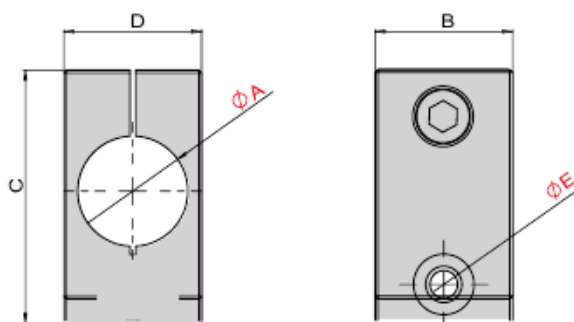

货号(PN)	型号(Model)	A	B	C	D	E	重量(Weight)
7.Y00051	SMBH1-8M5	$\phi 8$	14	35	12	$\phi 5.5$	15g
7.Y00052	SMBH1-8M6	$\phi 8$	14	35	12	$\phi 6.5$	12g
7.Y00053	SMBH1-12M5	$\phi 12$	20	39	16	$\phi 5.5$	30g
7.Y00002	SMBH1-12M6	$\phi 12$	20	39	16	$\phi 6.5$	25g
7.Y00054	SMBH1-12M8	$\phi 12$	20	45	25	$\phi 9$	42g
7.Y00055	SMBH1-20M6	$\phi 20$	20	50	25	$\phi 6.5$	48g
7.Y00056	SMBH1-20M8	$\phi 20$	20	50	25	$\phi 9$	51g

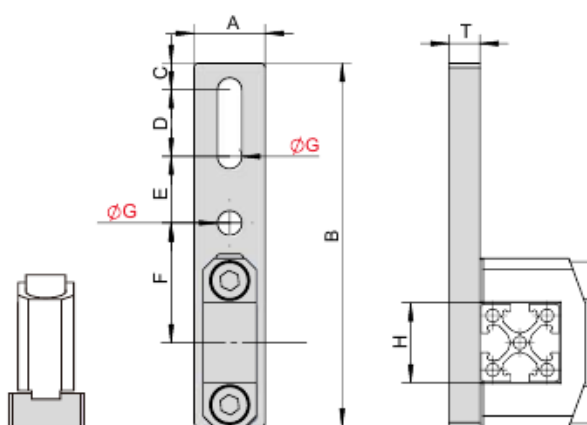

货号(PN)	型号(Model)	A	B	C	D	E	F	G	H	T	重量(Weight)
7.Y00869	SMBE7-18M5	16	82	6	15	15	27	$\phi 5.5$	18	7	20.5g
7.Y00870	SMBE7-18M6	16	82	6	15	15	27	$\phi 6.5$	18	7	20g
7.Y00871	SMBE7-25M5	16	90	7	15	15	30.5	$\phi 5.5$	25	7	22.5g
7.Y00872	SMBE7-25M6	16	90	7	15	15	30.5	$\phi 6.5$	25	7	22g

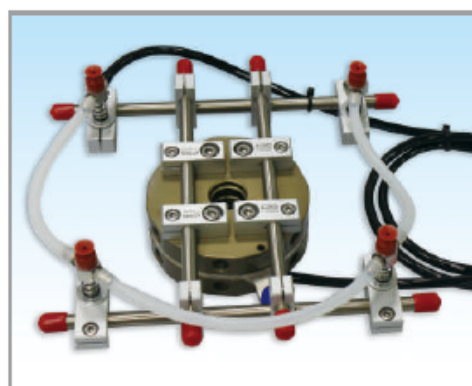
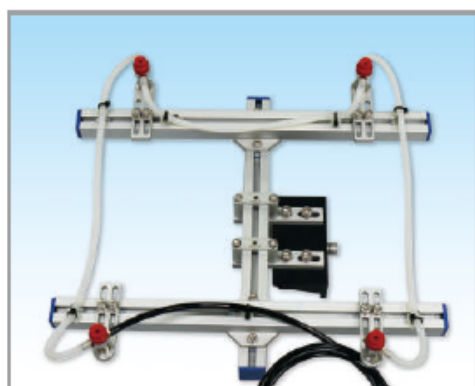

Profile- SUS Tube  
型材、钢管

Stents Module  
支架模组

Quick Changer  
快换

Grip Module  
夹具组件

Air Nipper  
气动剪刀

Vacuum Module  
真空组件

Accessory Components  
附件

# 弯臂

## Elbow Arm

Profile, SUS Tube  
型材、钢管

Stents Module  
支架模组

Quick Changer  
快换

Grip Module  
夹具组件

Air Nipper  
气动剪刀

Vacuum Module  
真空组件

Accessory Components  
附件

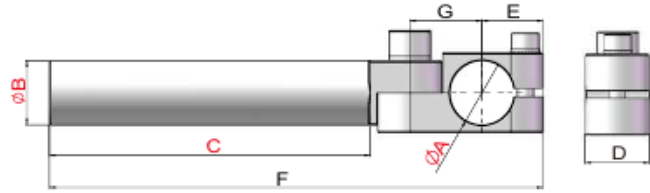

货号(PN)	型号(Model)	A(mm)	B(mm)	C(mm)	D(mm)	E(mm)	F(mm)	G(mm)	重量(Weight)
7.Y00388	SEA-1010L60	Ø10	Ø10	60	10	13	93	12.5	20g
7.Y00776	SEA-1212L60	Ø12	Ø12	60	12	15	98	14.5	22g
7.Y00389	SEA-1414L40	Ø14	Ø14	40	14	16	82	16.5	32g
7.Y00390	SEA-1414L80	Ø14	Ø14	80	14	16	122	16.5	42g
7.Y00391	SEA-1414L120	Ø14	Ø14	120	14	16	162	16.5	50g
7.Y00392	SEA-2020L50	Ø20	Ø20	50	20	19	104	22.5	70g
7.Y00393	SEA-2020L100	Ø20	Ø20	100	20	19	154	22.5	90g
7.Y00394	SEA-2020L150	Ø20	Ø20	150	20	19	204	22.5	120g
7.Y00395	SEA-3030L80	Ø30	Ø30	80	30	27	160	34.8	235g
7.Y00396	SEA-3030L140	Ø30	Ø30	140	30	27	220	34.8	300g
7.Y00397	SEA-3030L200	Ø30	Ø30	200	30	27	280	34.8	360g



# 重型弯臂

## Heavy Duty Elbow Arm

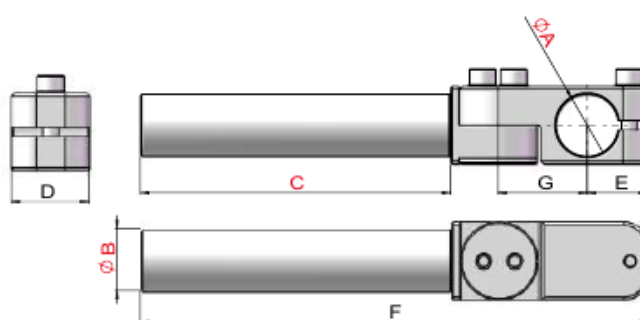

货号(PN)	7.Y00350	7.Y00351	7.Y00166	7.Y00352	7.Y00353	7.Y00354
型号(Model)	SEAH-2020L50	SEAH-2020L100	SEAH-2020L150	SEAH-3030L80	SEAH-3030L140	SEAH-3030L200
A(mm)	Ø20	Ø20	Ø20	Ø30	Ø30	Ø30
B(mm)	Ø20	Ø20	Ø20	Ø30	Ø30	Ø30
C(mm)	50	100	150	80	140	200
D(mm)	25	25	25	35	35	35
E(mm)	19.5	19.5	19.5	27.3	27.3	27.3
F(mm)	113.5	163.5	213.5	168.5	228.5	288.5
G(mm)	28.7	28.7	28.7	40.7	40.7	40.7
重量(Weight)	95g	115g	130g	330g	380g	435g



Profile- SUS Tube  
型材、钢管

Stents Module  
支架模组

Quick Changer  
快换

Grip Module  
夹具组件

Air Nipper  
气动剪刀

Vacuum Module  
真空组件

Accessory Components  
附件

# 真空吸盘弯臂

## Elbow Arm For Vacuum Cup

Profile, SUS Tube  
型材、钢管

Stents Module  
支架模组

Quick Changer  
快换

Grip Module  
夹具组件

Air Nipper  
气动剪刀

Vacuum Module  
真空组件

Accessory Components  
附件

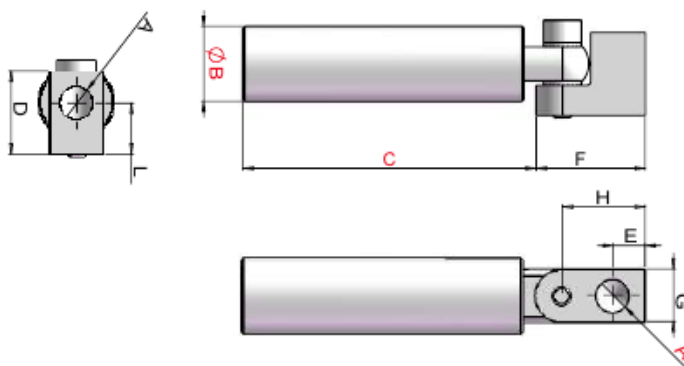

货号(PN)	型号(Model)	A(mm)	B(mm)	C(mm)	D(mm)	E(mm)	F(mm)	G(mm)	H(mm)	L(mm)	重量(Weight)
7.Y00432	SEAV-M510L45	M5	Ø10	45	16.5	5.5	19	10	14	11	18g
7.Y00433	SEAV-M510L90	M5	Ø10	90	16.5	5.5	19	10	14	11	27g
7.Y00258	SEAV-G1814L60	G1/8	Ø14	60	22	8.5	29	14	22	13.5	33g
7.Y00434	SEAV-G1814L120	G1/8	Ø14	120	22	8.5	29	14	22	13.5	50g
7.Y00435	SEAV-G1820L78	G1/8	Ø20	78	22	8.5	29	14	22	13.5	60g
7.Y00247	SEAV-G1820L153	G1/8	Ø20	153	22	8.5	29	14	22	13.5	100g
7.Y00436	SEAV-G1420L75	G1/4	Ø20	75	27	12	38	20	28	15	75g
7.Y00437	SEAV-G1420L150	G1/4	Ø20	150	27	12	38	20	28	15	115g



## 套筒螺母

Bush Nut

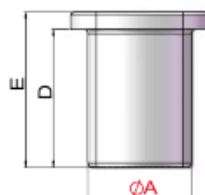
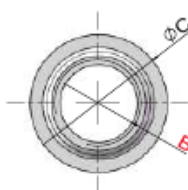

货号(PN)	型号(Model)	A	B	C	D	E	重量(Weight)
7.Y00271	SBNA-8M5	Ø8	M5x0.8	Ø12	8	10	1g
7.Y00272	SBNA-8M6	Ø8	M6x1.0	Ø12	8	10	1g
7.Y00273	SBNA-12M5	Ø12	M5x0.8	Ø16	16	18	5g
7.Y00274	SBNA-12M10	Ø12	M10x1.0	Ø16	16	18	3g
7.Y00276	SBNA-20M12	Ø20	M12x1.0	Ø24	16	18	11g
7.Y00277	SBNA-20M17	Ø20	M17x1.0	Ø24	16	18	5g

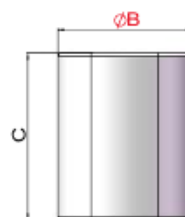
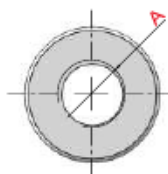

货号(PN)	型号(Model)	A	B	C	重量(Weight)
7.Y00275	SBNB-12PT18	PT1/8	Ø12	16	2g
7.Y00278	SBNB-20PT18	PT1/8	Ø20	25	17g

## 套筒

Bush

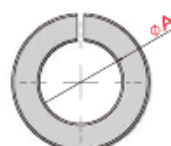
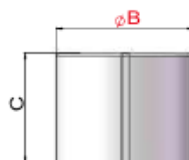

货号(PN)	型号(Model)	A	B	C	重量(Weight)
7.Y00280	SBND-1208	Ø8	Ø12	16	6g
7.Y00281	SBND-2012	Ø12	Ø20	16	9g
7.Y00282	SBND-2008	Ø8	Ø20	16	11g

Profile- SUS Tube  
型材、钢管

Stents Module  
支架模组

Quick Changer  
快换

Grip Module  
夹具组件

Air Nipper  
气动剪刀

Vacuum Module  
真空组件

Accessory Components  
附件

## 机器人末端快换装置

A quick changer device at the end of a robot

### 产品优势

Product advantages

#### 高精度

活塞调节机器人侧与夹具侧起到定位作用, 提供了较高重复定位精度。百万次循环测试表明实际精度要远远高于推荐值。

#### 高强度

大缸径设计的锁紧活塞具备强大的锁紧力, CRG机器人末端快速装置具有强大的抗力矩能力。

锁紧时不会因为高速的移动产生晃动, 避免了锁紧失效, 保证了重复定位精度。

#### 高性能

多锥面的设计锁紧机构, 选用了长寿命密封组件, 采用了高品质的弹性接触式探针, 保证了信号模块的紧密接触。

#### High-precision

The piston adjusting gripper side play the role of positioning, which provides high repeat positioning accuracy. One million cycle tests show that the actual accuracy is much higher than the recommended value.

#### High strength

The locking piston with large cylinder diameter has strong locking force, CRG robot end fast device has strong anti torque ability. When locking, there will be no shaking due to high-speed movement, thus avoiding locking failure and ensuring repeated positioning accuracy.

#### High performance

The locking mechanism with multi conical surface design, long life sealing components and high quality elastic contact probe are adopted to ensure the close contact of signal module.

自动快换安装使用示例  
Quick Changer Installation Example

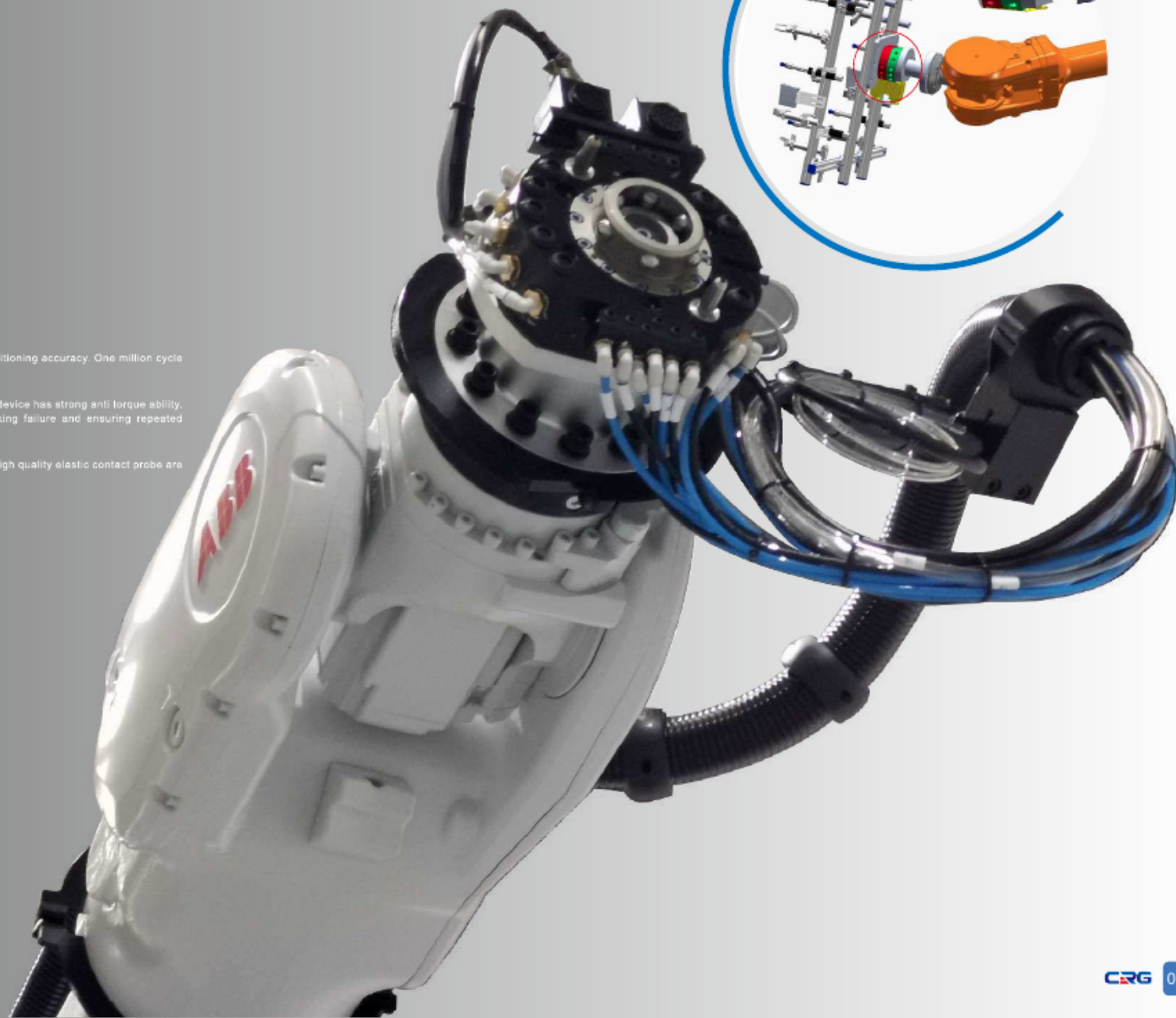
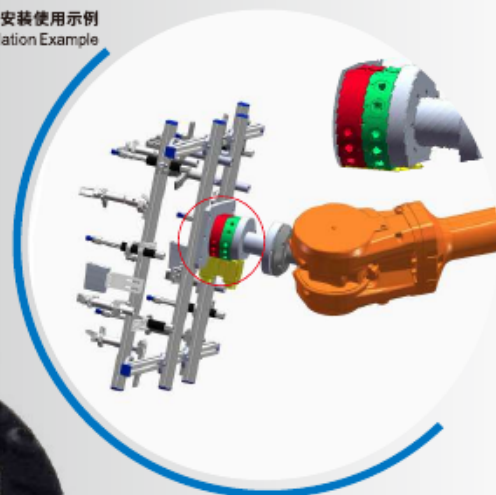

# 安装示意图

## Installation schematic

Profile, SUS Tube  
型材、钢管

Stents Module  
支架模组

Quick Changer  
快换

Grip Module  
夹具组件

Air Nipper  
气动剪刀

Vacuum Module  
真空组件

Accessory Components  
附件

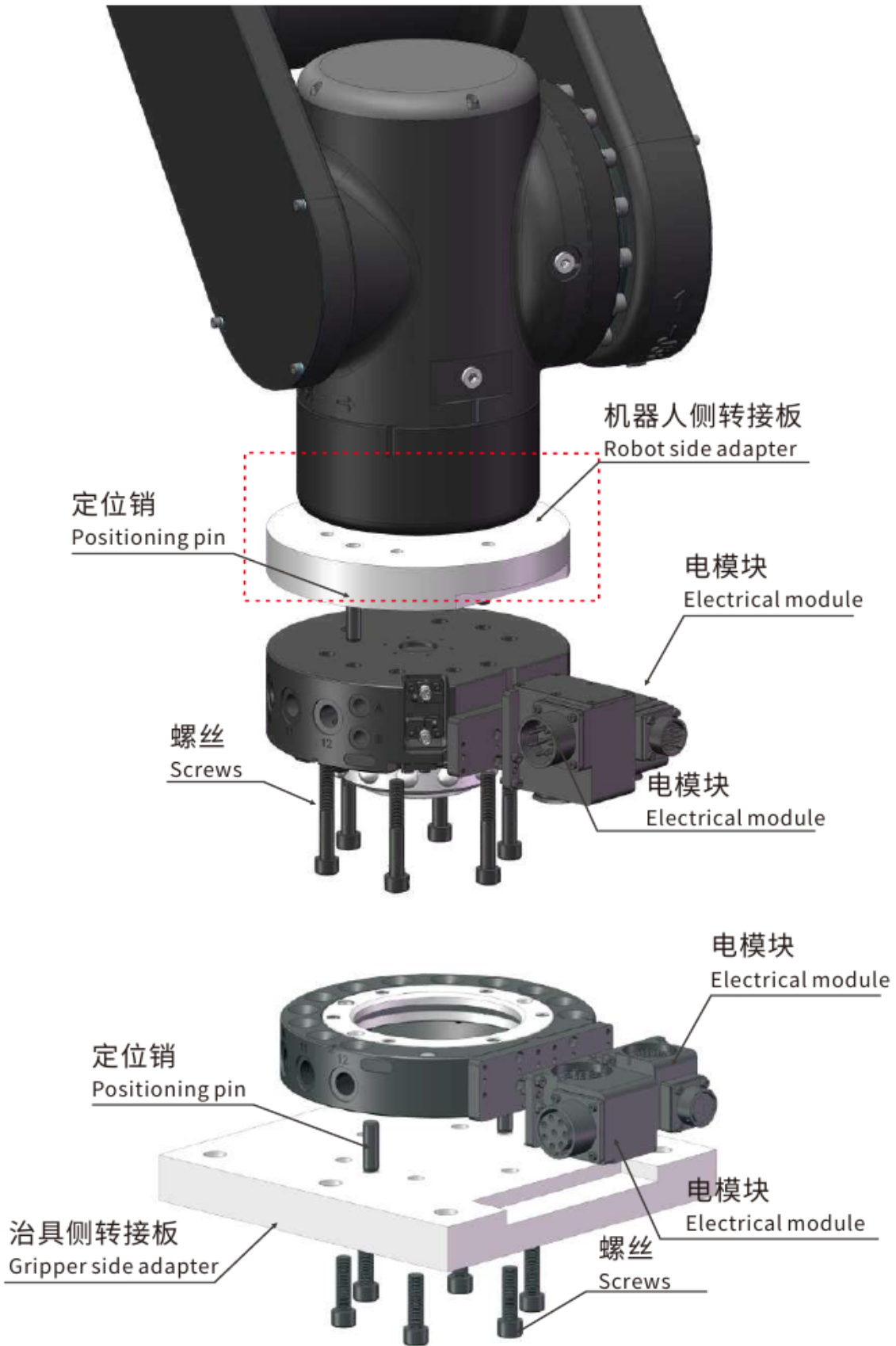

## 锁定和解锁气动连接

Lock and unlock pneumatic connections

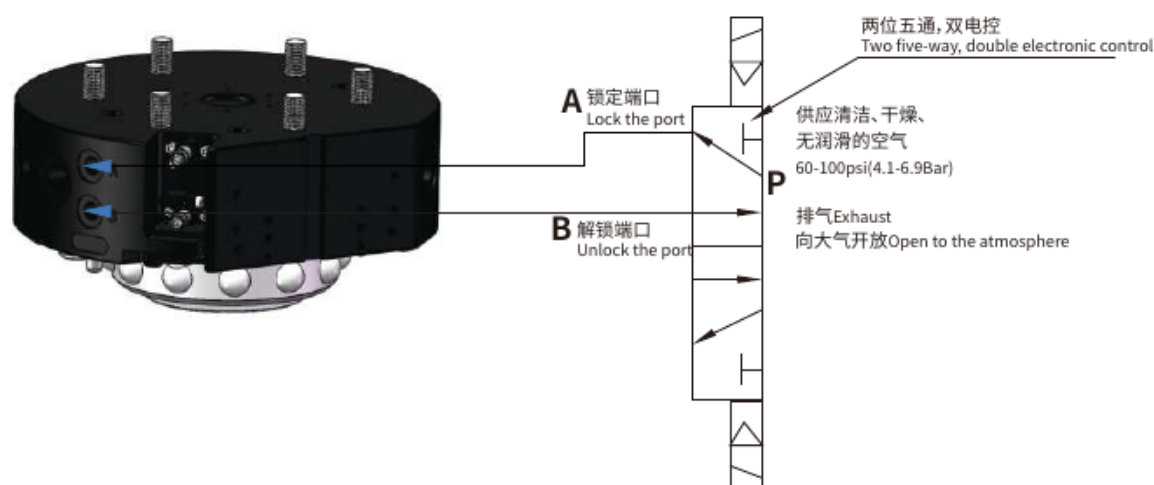

## 安全性能 (选配)

Safety capability (option)

三个安全性能开关,多重防护

Three safety capability switch, multiple protection

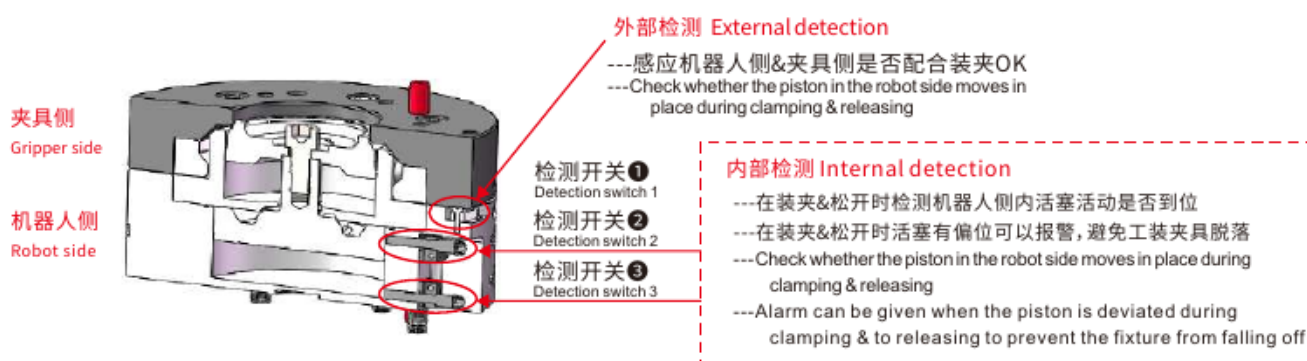

## 安全方式

Safe Way

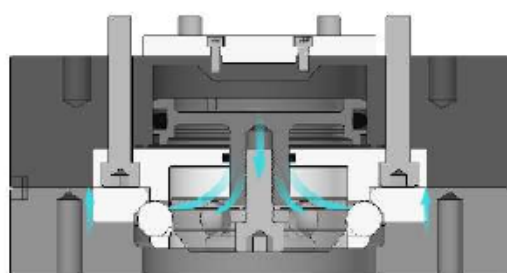

安全回路  
Safety circuit

1. 多个高强度锁紧钢珠保持机器人和工具的锁紧, 更安全、稳定。
2. 得益于精确的重复精度, 即使频繁更换, 工具也会被带到精准的操作位置。
3. 默认自锁式设计。气压停止供给的情况下, 机器人侧与工具侧也不会分离。

1. Multiple high-strength locking balls keep the robot and tools locked, making them safer and more stable.
2. Thanks to the precision of repetition, tools are brought to the precise operating position even if they are changed frequently.
3. Default self-locking design. The robot side and the tool side are not separated when the air pressure is stopped.

## 额定负载试验

Rated load test

Profile、SUS Tube  
型材、钢管

Stents Module  
支架模组

Quick Changer  
快换

Grip Module  
夹具组件

Air Nipper  
气动剪刀

Vacuum Module  
真空组件

Accessory Components  
附件

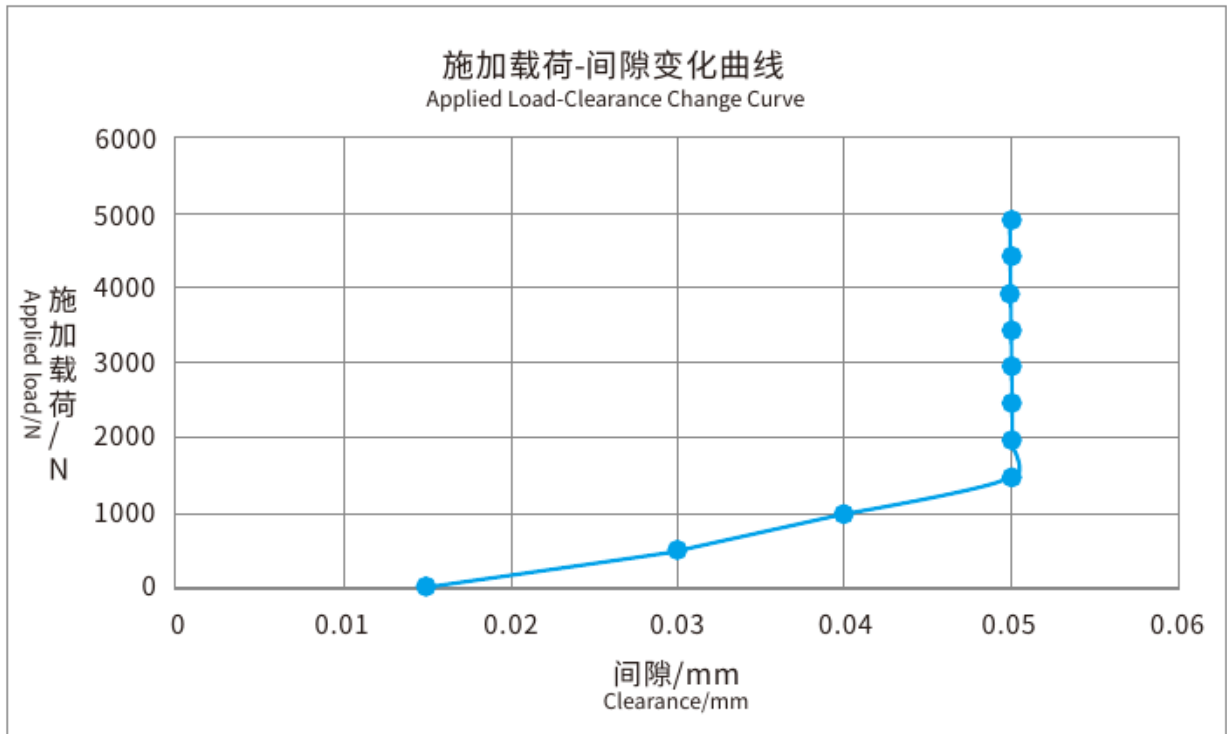

QCA-200自动快换

QCA-200 Quick Changer

## X-Y静态承载力矩试验

X-Y static load moment test

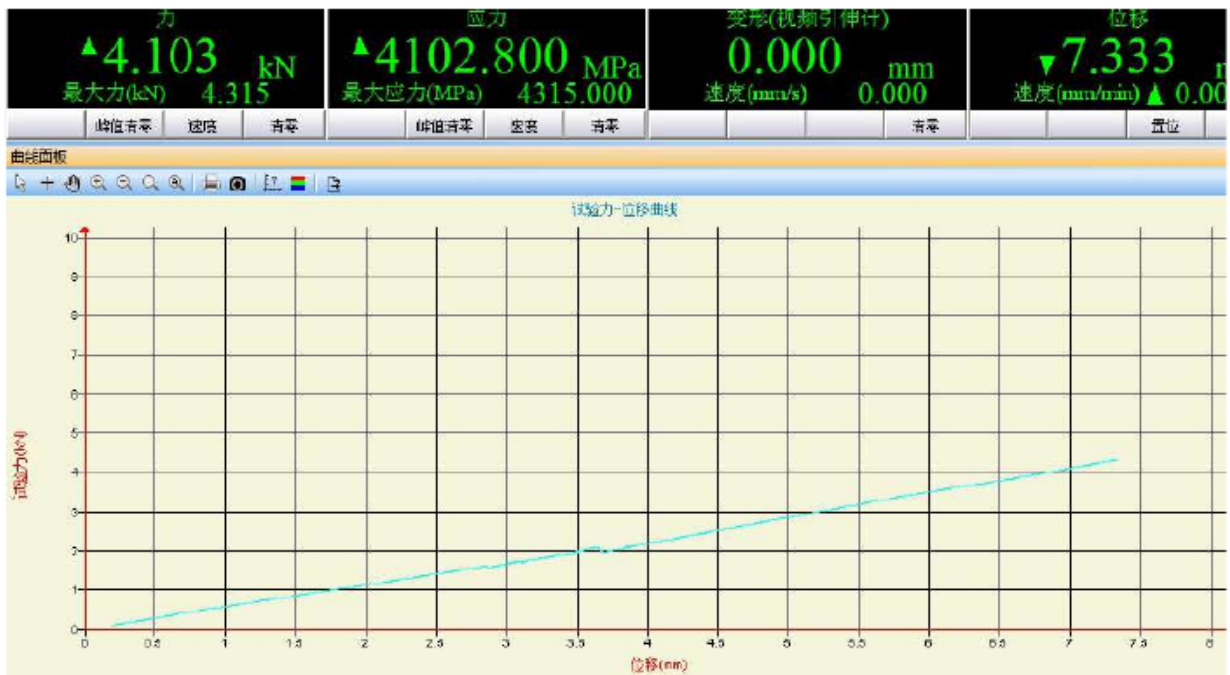

## 最大负载试验

Maximum load test

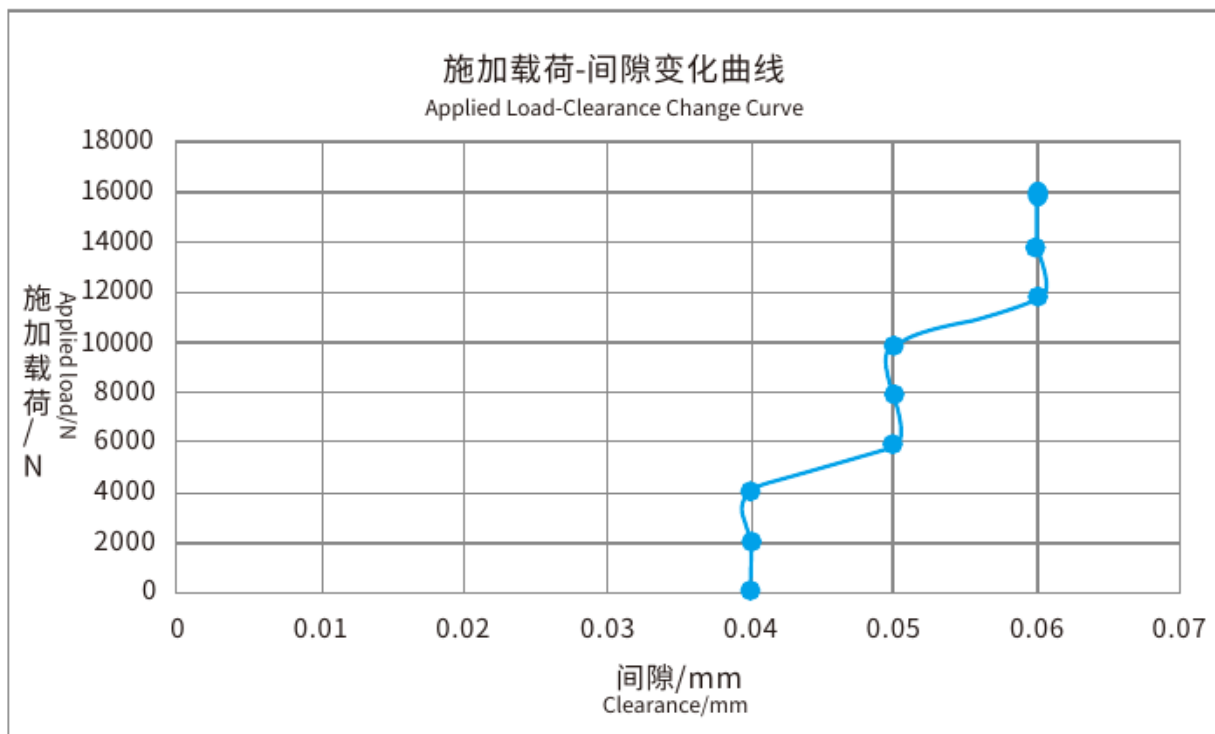

QCA-200自动快换  
QCA-200 Quick Changer

## Z向静态承载力矩试验

Z-direction static load moment test



Profile- SUS Tube  
型材、钢管

Stents Module  
支架模组

Quick Changer  
快换

Grip Module  
夹具组件

Air Nipper  
气动剪刀

Vacuum Module  
真空组件

Accessory Components  
附件

# 快换系列

## Quick Changer Series

Profile, SUS Tube  
型材、钢管

Stents Module  
支架模组

Quick Changer  
快换

Grip Module  
夹具组件

Air Nipper  
气动剪刀

Vacuum Module  
真空组件

Accessory Components  
附件

型号(Model)	最大负载 Max payload	气路 Gas path	锁紧力@80Psi (5.5Bar) Locking Force@80Psi (5.5Bar)	产品重量 Product weight
QCA-05	5kg	6-M5	620N	0.4kg
QCA-05	5kg	6-M5	620N	0.3kg
QCA-15	15kg	6-M5	1150N	0.3kg
QCA-25	25kg	12-M5	2400N	1.0kg
QCA-35	35kg	8-G1/8	2900N	1.4kg
QCA-35RS	35kg	8-G1/8	2900N	0.95kg
QCA-50	50kg	9-G1/8	4600N	1.7kg
QCA-S50	50kg	8-G1/8	5800N	1.9kg
QCA-S50RS	50kg	8-G1/8	5800N	1.25kg
QCA-100	100kg	7-G3/8	12000N	5.2kg
QCA-S100	100kg	5-G3/8	12000N	3.7kg
QCA-S100RS	100kg	5-G3/8	12000N	2.5kg
QCA-S150	150kg	8-G3/8	12000N	6.2kg
QCA-S150RS	150kg	8-G3/8	12000N	4.6kg
QCA-200	300kg	12-G3/8	16000N	9.0kg
QCA-200D1	300kg	8-G3/8	16000N	9.0kg
QCA-200RS-D1	300kg	8-G3/8	16000N	6.75kg
QCA-300	300kg	5-NPT3/8,4-NPT1/2	31000N	9.3kg
QCA-S350	350kg	/	31000N	9.4kg
QCA-S500	500kg	/	37800N	23.4kg

机器人侧  
Robot side



90°接插件(母头)  
90° connector (female)

机器人侧信号模块  
signal module of robot side

夹具侧  
Gripper side



90°接插件(公头)  
90° connector (male)

夹具侧信号模块  
signal module of gripper side

# 自动快换 Quick Changer

## QCA-05

\*材质:钢性材料\*Material: steel \*建议安装后再通气测试\*Recommended to ventilate and test after installation



机器人侧  
Robot side

货号(PN)	8.Y00355
型号(Model)	QCA-05R



夹具侧  
Gripper side

货号(PN)	8.Y00356
型号(Model)	QCA-05G



机器人侧带开关  
Robot side strap switch

货号(PN)	8.Y00355-SP	8.Y00355-SN
型号(Model)	QCA-05R-SP	QCA-05R-SN
信号检测类别 Signal Detection Category	PNP	NPN

## 产品参数

### Parameter

- |                             |   |
|-----------------------------|---|
| 1.最大负载: 5 kg                | 1.Max payload: 5kg                              |
| 2.锁紧力@80Psi (5.5Bar): 620N  | 2.Locking force@80Psi (5.5Bar): 620 N           |
| 3.静态承载力矩 (X&Y): 23.4Nm      | 3.Static Load torque (X&Y): 23.4 Nm             |
| 4.静态承载力矩 (Z): 31.5 Nm       | 4.Static Load torque (Z): 31.5 Nm               |
| 5.位置重复精度 (X,Y&Z): ±0.015 mm | 5.Repeatability accuracy (X,Y&Z): ±0.015 mm     |
| 6.机器人侧带开关重量: 0.36kg         | 6.Robot side's strap switch weight: 0.36 kg     |
| 7.机器人侧重量: 0.3 kg            | 7.Robot side's weight: 0.3kg                    |
| 8.夹具侧重量: 0.1 kg             | 8.Gripper side's weight: 0.1 kg                 |
| 9.最大允许角偏移: ±1°              | 9.Maximum allowable angle deviation: ±1°        |
| 10.直通型气孔尺寸(数量):(6) M5       | 10.Size of straight air hole (quantity): (6) M5 |

## 机器人侧

### Robot side

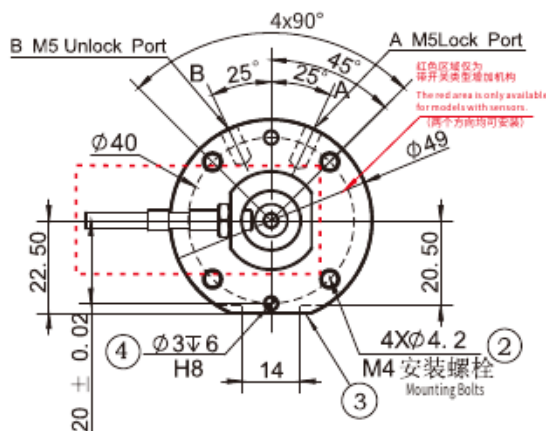
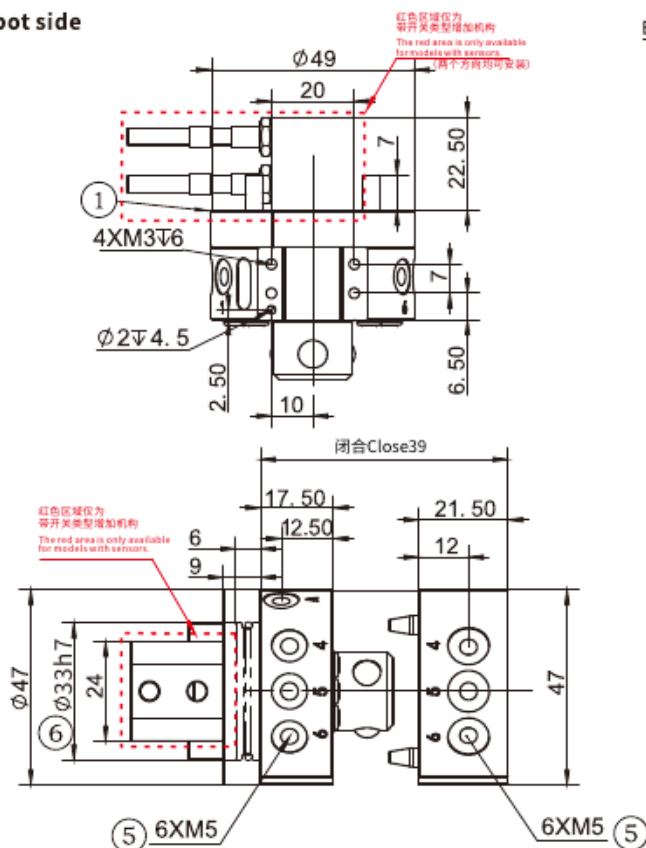

A. 空气接口锁紧 The air connection locked

B. 空气接口松开 Air connection released

1. 机器人侧连接 Robot side connection
2. 螺纹连接用通孔 Threaded through-holes
3. 选配件安装面 Optional mounting surface
4. 连接用定位销 Positioning pin
5. 直通型气孔 Straight through air hole
6. 中心定位用 Central positioning
7. 防护底座 Protective base

# 自动快换 Quick Changer

## 夹具侧 Gripper side

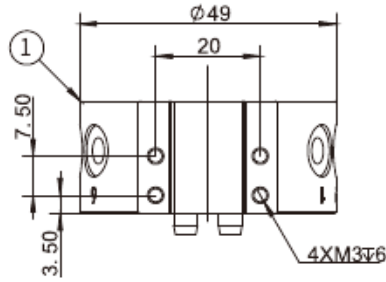
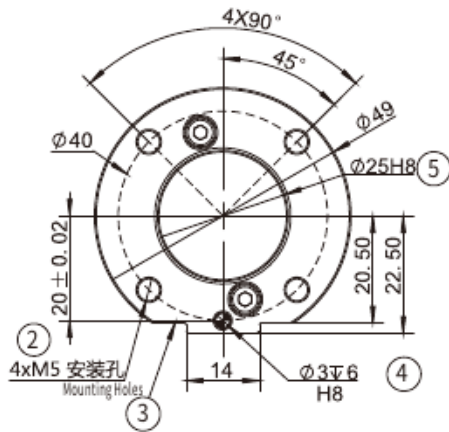

1. 夹具侧连接用 Gripper side connection
2. 螺纹连接用孔 Threaded holes
3. 选配件安装面 Optional mounting surface
4. 连接用定位销 Positioning pin
5. 中心定位 Central positioning

# 适用模块 Applicable module

## 信号模块 Signal Module

产品名称 Product Name	型号 Model	货号 PN	工作电压 Working Voltage	工作电流 Working Current	接插件 Connector	接插件货号 Connector PN
机器人侧信号模块 Robot side signal module	QCSM-15R1	7.Y00965	24V	2.5A	DB15R1-1000 <sup>①</sup>	1.Y10163
夹具侧信号模块 Gripper side signal module	QCSM-15G1	7.Y00966	24V	2.5A	DB15G1-1000 <sup>①</sup>	1.Y10437

① 连接线材长为1米 The cable's length is 1 meter

## 信号模块-直出线 Signal Module-Straight Out Line

产品名称 Product Name	型号 Model	货号 PN
机器人侧15芯电模块 Robot side 15-core electric module	QCSM-15R1-1000	7.Y02097
夹具侧15芯电模块 Gripper side 15-core electric module	QCSM-15G1-1000	7.Y02098

## 贴面信号模块 Surface-Mount Signal Module

产品名称 Product Name	型号 Model	货号 PN
机器人侧信号模块 Robot side signal module	QCSM-TSR1-SP(SN)	7.Y03880/7.Y03901
夹具侧信号模块 Gripper side signal module	QCSM-TSG1	7.Y03881

## 通讯模块 Communication Module

产品名称 Product Name	型号 Model	货号 PN
机器人侧RJ45S伺服模块 Robot side RJ45S servo module	QCSM-RJ45-1M-06R	7.Y02129
夹具侧RJ45S伺服模块 Gripper side RJ45S servo module	QCSM-RJ45-1M-06G	7.Y02130

## 强电模块 Power Module

产品名称 Product Name	型号 Model	货号 PN
机器人侧高频模块 Robot side high frequency module	QCSM-08R-1000	7.Y02084
夹具侧高频模块 Gripper side high frequency module	QCSM-08G-1000	7.Y02085
机器人侧高频模块 Robot side high frequency module	QCHFM-02R-1000	7.Y02086
夹具侧高频模块 Gripper side high frequency module	QCHFM-02G-1000	7.Y02087

Profile, SUS Tube  
型材、钢管

Stents Module  
支架模组

Quick Changer  
快换

Grip Module  
夹具组件

Air Nipper  
气动剪刀

Vacuum Module  
真空组件

Accessory Components  
附件

# 自动快换 Quick Changer

## QCA-05

\*材质: 钢性材料\* Material: steel



机器人侧带开关  
Robot side strap switch

货号(PN)	8.Y01066
型号(Model)	QCA-05R1-SN
信号检测类别 Signal Detection Category	NPN



夹具侧  
Gripper side

货号(PN)	8.Y01067
型号(Model)	QCA-05G1

## 产品参数

### Parameter

- |                                   |   |
|-----------------------------------|---|
| 1. 最大负载: 5 kg                     | 1. Max payload: 5kg                                 |
| 2. 锁紧力@80Psi (5.5Bar): 620N       | 2. Locking force@80Psi (5.5Bar): 620 N              |
| 3. 静态承载力矩 (X&Y): 23.4Nm           | 3. Static Load torque (X&Y): 23.4 Nm                |
| 4. 静态承载力矩 (Z): 31.5 Nm            | 4. Static Load torque (Z): 31.5 Nm                  |
| 5. 位置重复精度 (X,Y&Z): $\pm 0.015$ mm | 5. Repeatability accuracy (X,Y&Z): $\pm 0.015$ mm   |
| 6. 重量-锁紧后: 0.3 kg                 | 6. Weight after locked: 0.3 kg                      |
| 7. 机器人侧重量: 0.2 kg                 | 7. Robot side's weight: 0.2kg                       |
| 8. 夹具侧重量: 0.1 kg                  | 8. Gripper side's weight: 0.1 kg                    |
| 9. 最大允许角偏移: $\pm 1^\circ$         | 9. Maximum allowable angle deviation: $\pm 1^\circ$ |
| 10. 直通型气孔尺寸(数量): (6) M5           | 10. Size of straight air hole (quantity): (6) M5    |

## 机器人侧

### Robot side

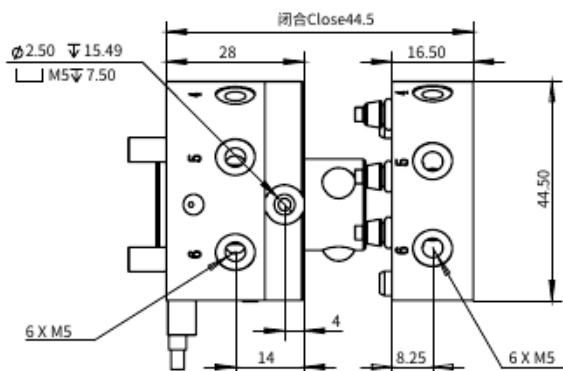
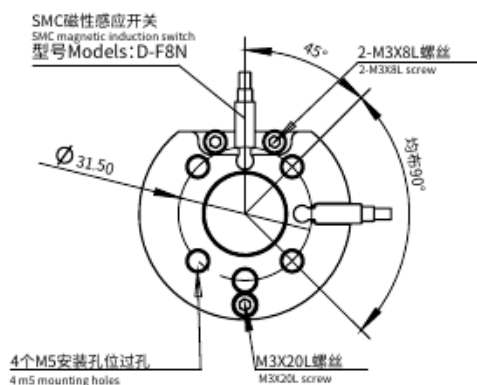
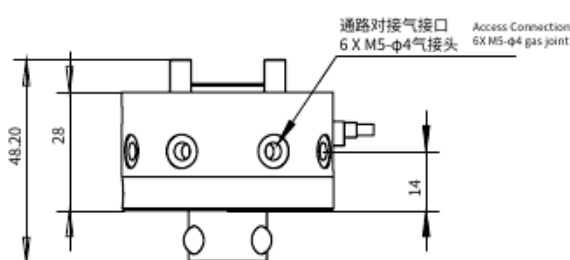
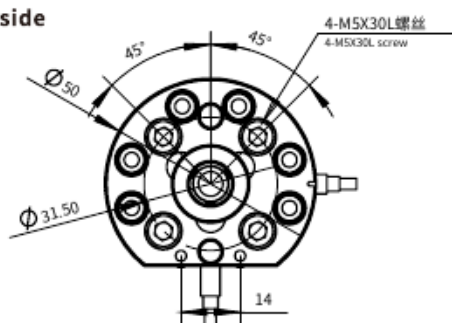

# 自动快换 Quick Changer

## 夹具侧 Gripper side

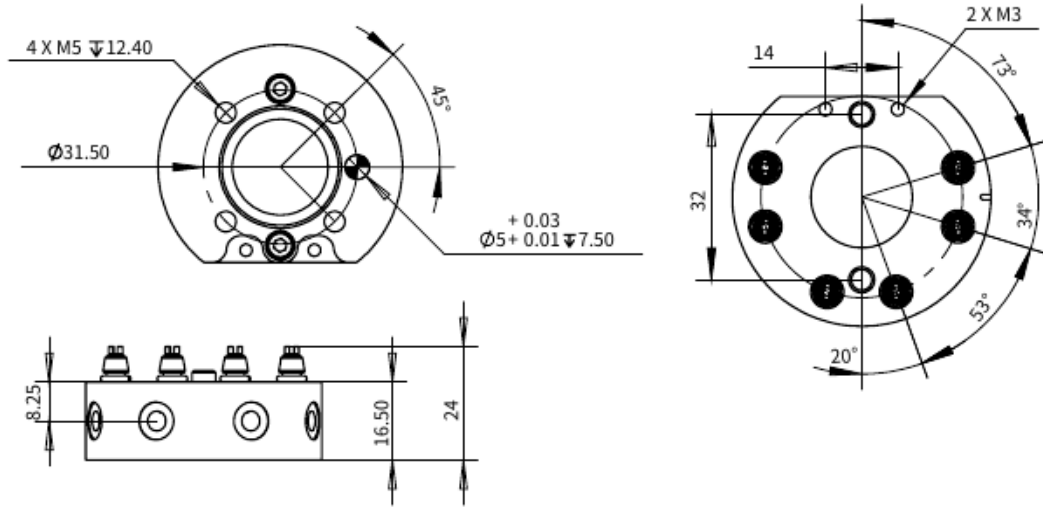

## 技术说明

### Technical note

1. 主盘侧标配安装螺钉和磁性开关感应器
2. 主盘侧和工具盘侧没有标配模块
3. 锁紧方式: 钢珠锁紧

1. Mounting screws and magnetic switch sensor
2. There are no standard modules on the main disk side and tool disk side
3. Locking mode: steel ball locking

# 自动快换 Quick Changer

## QCA-15



机器人侧  
Robot side

货号(PN)	8.Y00353
型号(Model)	QCA-15R



夹具侧  
Gripper side

货号(PN)	8.Y00354
型号(Model)	QCA-15G



机器人侧带开关  
Robot side strap switch

货号(PN)	8.Y00353-SP	8.Y00353-SN
型号(Model)	QCA-15R-SP	QCA-15R-SN
信号检测类别 Signal Detection Category	PNP	NPN

### 产品参数

#### Parameter

- 1.最大负载: 15 kg
- 2.锁紧力@80Psi (5.5Bar): 1150N
- 3.静态承载力矩 (X&Y): 26.5Nm
- 4.静态承载力矩 (Z): 35.3 Nm
- 5.位置重复精度 (X,Y&Z): ±0.015 mm
- 6.机器人侧带开关重量: 0.26 kg
- 7.机器人侧重量: 0.2 kg
- 8.夹具侧重量: 0.1 kg
- 9.最大允许角偏移: ±1°
- 10.直通型气孔尺寸(数量): (6) M5

1. Max payload: 15kg
2. Locking force@80Psi (5.5Bar): 1150 N
3. Static Load torque (X&Y): 26.5 Nm
4. Static Load torque (Z): 35.3 Nm
5. Repeatability accuracy (X,Y&Z): ±0.015 mm
6. Robot side's strap switch weight: 0.26 kg
7. Robot side's weight: 0.2 kg
8. Gripper side's weight: 0.1 kg
9. Maximum allowable angle deviation: ±1°
10. Size of straight air hole( quantity) : ( 6) M5

### 机器人侧

#### Robot side

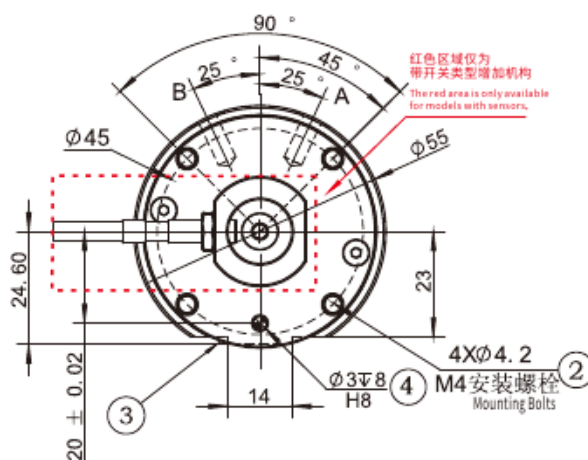
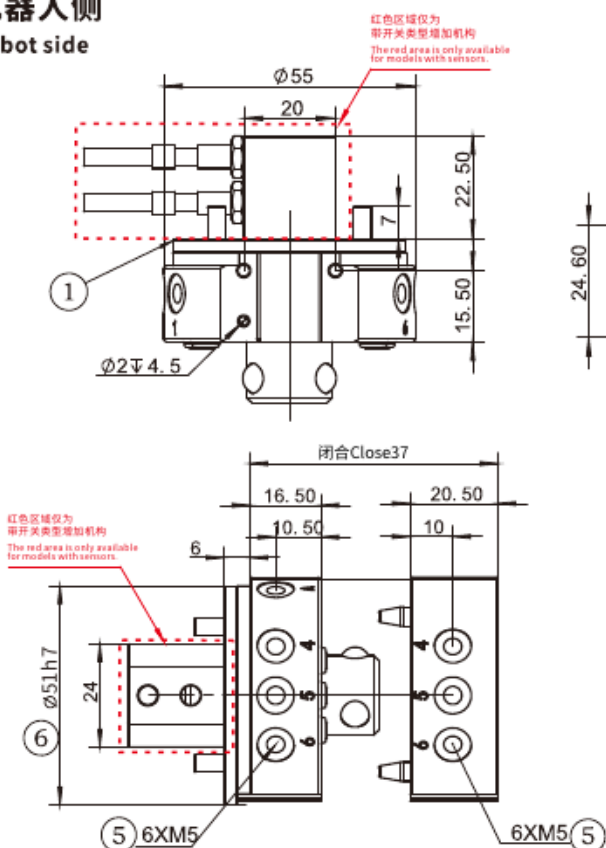

- A. 空气接口锁紧 The air connection locked  
B. 空气接口松开 Air connection released
1. 机器人侧连接 Robot side connection
  2. 螺纹连接用通孔 Threaded through-holes
  3. 选配件安装面 Optional mounting surface
  4. 连接用定位销 Positioning pin
  5. 直通型气孔 Straight through air hole
  6. 中心定位用 Central positioning

# 自动快换 Quick Changer

## 夹具侧 Gripper side

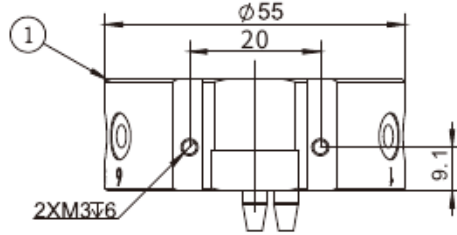
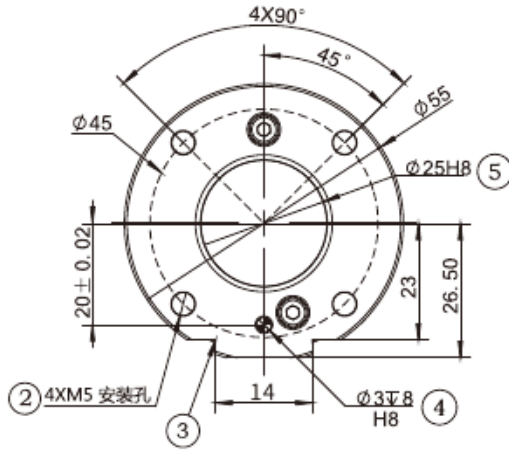

1. 夹具侧连接用 Gripper side connection
2. 螺纹连接用孔 Threaded holes
3. 选配件安装面 Optional mounting surface
4. 连接用定位销 Positioning pin
5. 中心定位用 Central positioning

# 适用模块 Applicable module

## 信号模块 Signal Module

产品名称 Product Name	型号 Model	货号 PN	工作电压 Working Voltage	工作电流 Working Current	接插件 Connector	接插件货号 Connector PN
机器人侧信号模块 Robot side signal module	QCSM-15R1	7.Y00965	24V	2.5A	DB15R1-1000 <sup>①</sup>	1.Y10163
夹具侧信号模块 Gripper side signal module	QCSM-15G1	7.Y00966	24V	2.5A	DB15G1-1000 <sup>①</sup>	1.Y10437

① 连接线材长为1米 The cable's length is 1 meter

## 信号模块-直出线 Signal Module-Straight Out Line

产品名称 Product Name	型号 Model	货号 PN
机器人侧15芯电模块 Robot side 15-core electric module	QCSM-15R1-1000	7.Y02097
夹具侧15芯电模块 Gripper side 15-core electric module	QCSM-15G1-1000	7.Y02098

## 贴面信号模块 Surface-Mount Signal Module

产品名称 Product Name	型号 Model	货号 PN
机器人侧信号模块 Robot side signal module	QCSM-TSR1-SP(SN)	7.Y03880/7.Y03901
夹具侧信号模块 Gripper side signal module	QCSM-TSG1	7.Y03881

## 通讯模块 Communication Module

产品名称 Product Name	型号 Model	货号 PN
机器人侧RJ45S伺服模块 Robot side RJ45S serve module	QCSM-RJ45-1M-06R	7.Y02129
夹具侧RJ45S伺服模块 Gripper side RJ45S serve module	QCSM-RJ45-1M-06G	7.Y02130

## 强电模块 Power Module

产品名称 Product Name	型号 Model	货号 PN
机器人侧高频模块 Robot side high frequency module	QCSM-08R-1000	7.Y02084
夹具侧高频模块 Gripper side high frequency module	QCSM-08G-1000	7.Y02085
机器人侧高频模块 Robot side high frequency module	QCHFM-02R-1000	7.Y02086
夹具侧高频模块 Gripper side high frequency module	QCHFM-02G-1000	7.Y02087

Profile, SUS Tube  
型材、钢管

Stents Module  
支架模组

Quick Changer  
快换

Grip Module  
夹具组件

Air Blipper  
气动剪刀

Vacuum Module  
真空组件

Accessory Components  
附件

# 自动快换

## Quick Changer

### QCA-25



机器人侧  
Robot side



夹具侧  
Gripper side



机器人侧带开关  
Robot side strap switch

货号(PN)	8.Y00460
型号(Model)	QCA-25R

货号(PN)	8.Y00461
型号(Model)	QCA-25G

货号(PN)	8.Y00460-SP	8.Y00460-SN
型号(Model)	QCA-25R-SP	QCA-25R-SN
信号检测类别 Signal Detection Category	PNP	NPN

### 产品参数

#### Parameter

- 1.最大负载: 25 kg
- 2.锁紧力@80Psi (5.5Bar): 2400N
- 3.静态承载力矩(X&Y): 59Nm
- 4.静态承载力矩(Z): 80 Nm
- 5.位置重复精度(X,Y&Z): ±0.015 mm
- 6.机器人侧带开关重量: 0.65kg
- 7.机器人侧重量: 0.6 kg
- 8.夹具侧重量: 0.4kg
- 9.最大允许角偏移: ±1°
- 10.直通型气孔尺寸(数量): (12) M5

- 1.Max payload: 25kg
- 2.Locking force@80Psi (5.5Bar): 2400 N
- 3.Static Load torque (X&Y): 59 Nm
- 4.Static Load torque (Z): 80 Nm
- 5.Repeatability accuracy (X,Y&Z): ±0.015 mm
- 6.Robot side's strap switch weight: 0.65kg
- 7.Robot side's weight: 0.6 kg
- 8.Gripper side's weight: 0.4 kg
- 9.Maximum allowable angle deviation: ±1°
- 10.Size of straight air hole (quantity): (12)M5

### 机器人侧

#### Robot side

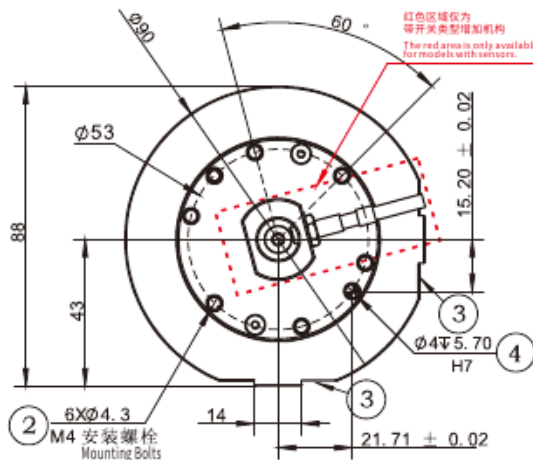
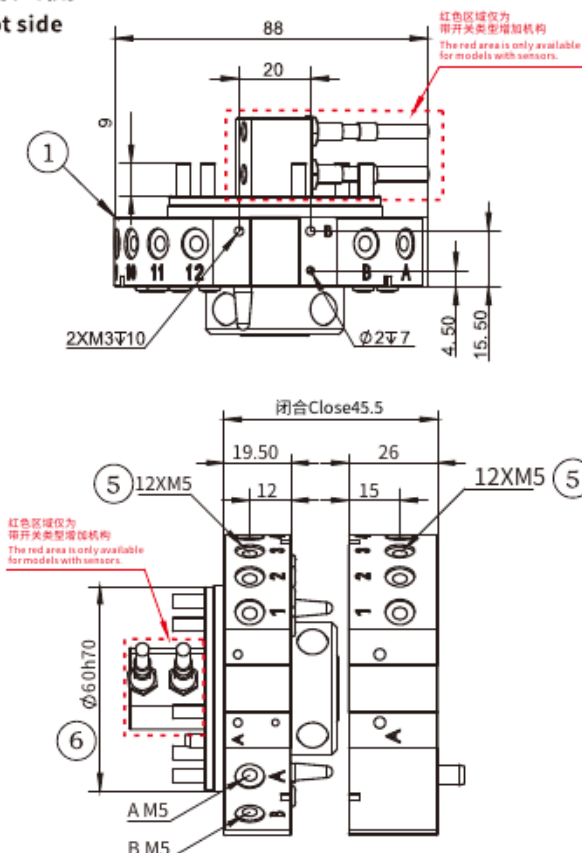

- A. 空气接口锁紧 The air connection locked  
 B. 空气接口松开 Air connection released
1. 机器人侧连接 Robot side connection
  2. 螺纹连接用通孔 Threaded through-holes
  3. 选配件安装面 Optional mounting surface
  4. 连接用定位销 Positioning pin
  5. 直通型气孔 Straight through air hole
  6. 中心定位用 Central positioning

# 自动快换 Quick Changer

## 夹具侧 Gripper side

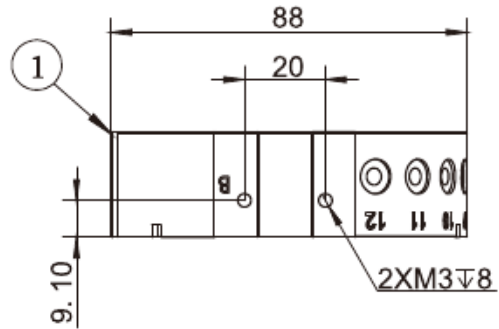
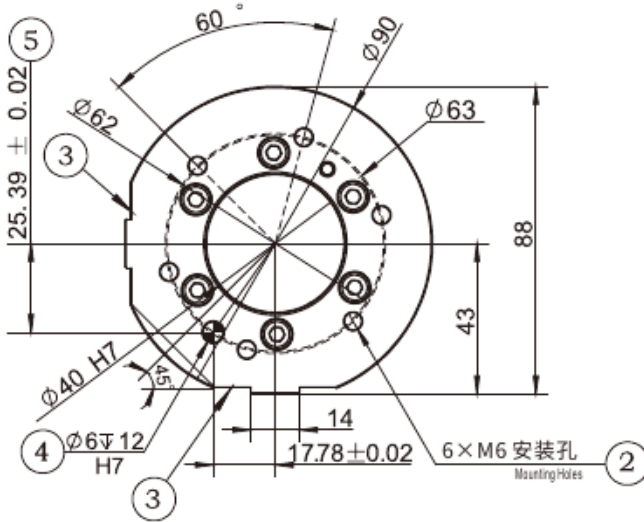

1. 夹具侧连接用 Gripper side connection
2. 螺纹连接用孔 Threaded holes
3. 选配件安装面 Optional mounting surface
4. 连接用定位销 Positioning pin
5. 中心定位用 Central positioning

# 适用模块 Applicable module

## 信号模块 Signal Module

产品名称 Product Name	型号 Model	货号 PN	工作电压 Working Voltage	工作电流 Working Current	接插件 Connector	接插件货号 Connector PN
机器人侧信号模块 Robot side signal module	QCSM-15R1	7.Y00965	24V	2.5A	DB15R1-1000 <sup>①</sup>	1.Y10163
夹具侧信号模块 Gripper side signal module	QCSM-15G1	7.Y00966	24V	2.5A	DB15G1-1000 <sup>①</sup>	1.Y10437

① 连接线材长为1米 The cable's length is 1 meter

## 信号模块-直出线 Signal Module-Straight Out Line

产品名称 Product Name	型号 Model	货号 PN
机器人侧15芯电模块 Robot side 15-core electric module	QCSM-15R1-1000	7.Y02097
夹具侧15芯电模块 Gripper side 15-core electric module	QCSM-15G1-1000	7.Y02098

## 贴面信号模块 Surface-Mount Signal Module

产品名称 Product Name	型号 Model	货号 PN
机器人侧信号模块 Robot side signal module	QCSM-TSR1-SP(SN)	7.Y03880/7.Y03901
夹具侧信号模块 Gripper side signal module	QCSM-TSG1	7.Y03881

## 通讯模块 Communication Module

产品名称 Product Name	型号 Model	货号 PN
机器人侧RJ45S伺服模块 Robot side RJ45S servo module	QCSM-RJ45-1M-06R	7.Y02129
夹具侧RJ45S伺服模块 Gripper side RJ45S servo module	QCSM-RJ45-1M-06G	7.Y02130

## 强电模块 Power Module

产品名称 Product Name	型号 Model	货号 PN
机器人侧高频模块 Robot side high frequency module	QCSM-08R-1000	7.Y02084
夹具侧高频模块 Gripper side high frequency module	QCSM-08G-1000	7.Y02085
机器人侧高频模块 Robot side high frequency module	QCHFM-02R-1000	7.Y02086
夹具侧高频模块 Gripper side high frequency module	QCHFM-02G-1000	7.Y02087

Profile、SUS Tube  
型材、钢管

Stents Module  
支架模组

Quick Changer  
快换

Grip Module  
夹具组件

Air Blipper  
气筒

Vacuum Module  
真空组件

Accessory Components  
附件

# 自动快换

Quick Changer

QCA-35RS **NEW**



机器人侧  
Robot side



机器人侧  
Robot side

货号 (PN)	8.Y01311
型号 (Model)	QCA-35RS

货号 (PN)	8.Y01316	8.Y01317
型号 (Model)	QCA-35RS-SP	QCA-35RS-SN
信号检测类别 Signal Detection Category	PNP	NPN

## 产品参数

### Parameter

- 1.最大负载: 25~35 kg
- 2.锁紧力@80Psi (5.5Bar):2900N
- 3.静态承载力矩 (X&Y): 88.5Nm
- 4.静态承载力矩 (Z): 105 Nm
- 5.位置重复精度 (X,Y&Z): ±0.015 mm
- 6.机器人侧重量: 0.95 kg
- 7.机器人侧带开关重量: 0.96kg
- 8.最大允许角偏移: ±1°
- 9.直通型气孔尺寸 (数量): (8) G1/8
- 10.增加弹簧结构 断气后双重安全防护掉落

1. Max payload: 25~35kg
2. Locking force@80Psi (5.5Bar): 2900 N
3. Static Load torque (X&Y): 88.5 Nm
4. Static Load torque (Z): 105 Nm
5. Repeatability accuracy (X,Y&Z) ±0.015 mm
6. Robot side's weight: 0.95 kg
7. Robot side's strap switch weight: 0.96kg
8. Maximum allowable angle deviation: ±1°
9. Size of straight air hole (quantity): (8) G1/8
10. Enhanced spring mechanism Dual safety protection against falling after air supply interruption

## 机器人侧

### Robot side

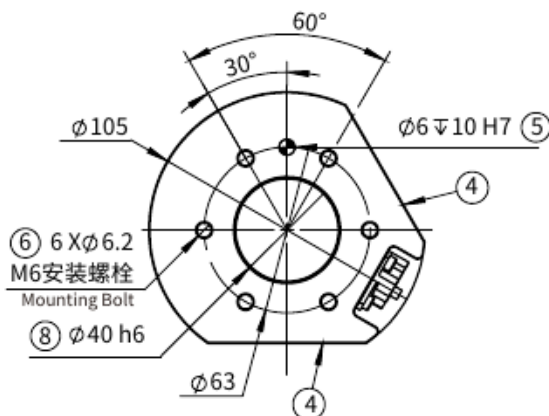
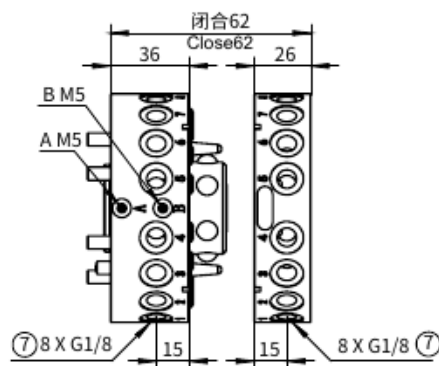
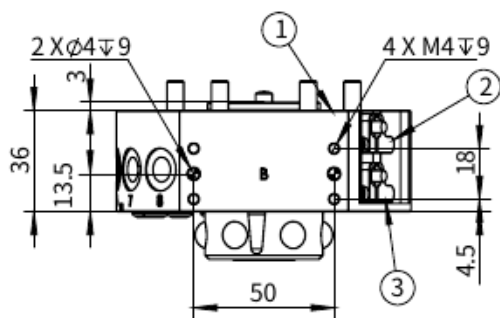

- |                |  |
|----------------|--|
| A. 空气接口锁紧      | A. Air Interface Locked                    |
| B. 空气接口松开      | B. Air Interface Unlocked                  |
| 1. 机器人侧连接面     | 1. Robot-side Connection Surface           |
| 2. 监控位置松开 (选配) | 2. Monitoring Position Unlocked (Optional) |
| 3. 监控位置锁紧 (选配) | 3. Monitoring Position Locked (Optional)   |
| 4. 选配件安装面      | 4. Optional Component Mounting Surface     |
| 5. 连接用定位销孔     | 5. Positioning Pin Hole for Connection     |
| 6. 螺纹连接用通孔     | 6. Through Hole for Threaded Connection    |
| 7. 直通型气孔       | 7. Straight-Through Air Port               |
| 8. 安装用定位环      | 8. Positioning Ring for Installation       |
- 机器人侧安装孔 ISO-9409-1-63-6-M6 Robot-Side Mounting Hole ISO-9409-1-63-6-M6

Profile- SUS Tube  
型材、钢管

Stents Module  
支架模组

Quick Changer  
快换

Grip Module  
夹具组件

Air Nipper  
气动剪刀

Vacuum Module  
真空组件

Accessory Components  
附件

# 自动快换

## Quick Changer

### QCA-35



机器人侧  
Robot side

货号(PN)	8.Y00351
型号(Model)	QCA-35R



夹具侧  
Gripper side

货号(PN)	8.Y00352
型号(Model)	QCA-35G



机器人侧带开关  
Robot side strap switch

货号(PN)	8.Y00351-SP	8.Y00351-SN
型号(Model)	QCA-35R-SP	QCA-35R-SN
信号检测类别 Signal Detection Category	PNP	NPN

### 产品参数

#### Parameter

- |                             |   |
|-----------------------------|---|
| 1.最大负载: 25~35 kg            | 1.Max payload: 25~35kg                            |
| 2.锁紧力@80Psi (5.5Bar): 2900N | 2.Locking force@80Psi (5.5Bar): 2900 N            |
| 3.静态承载力矩 (X&Y): 88.5Nm      | 3.Static Load torque (X&Y): 88.5 Nm               |
| 4.静态承载力矩 (Z): 105 Nm        | 4.Static Load torque (Z): 105 Nm                  |
| 5.位置重复精度 (X,Y&Z): ±0.015 mm | 5.Repeatability accuracy (X,Y&Z) ±0.015 mm        |
| 6.机器人侧带开关重量: 0.95 kg        | 6.Robot side's strap switch weight: 0.95 kg       |
| 7.机器人侧重量: 0.9 kg            | 7.Robot side's weight: 0.9 kg                     |
| 8.夹具侧重量: 0.5 kg             | 8.Gripper side's weight: 0.5 kg                   |
| 9.最大允许角偏移: ±1°              | 9.Maximum allowable angle deviation: ±1°          |
| 10.直通型气孔尺寸 (数量):(8) G1/8    | 10.Size of straight air hole (quantity): (8) G1/8 |

### 机器人侧

#### Robot side

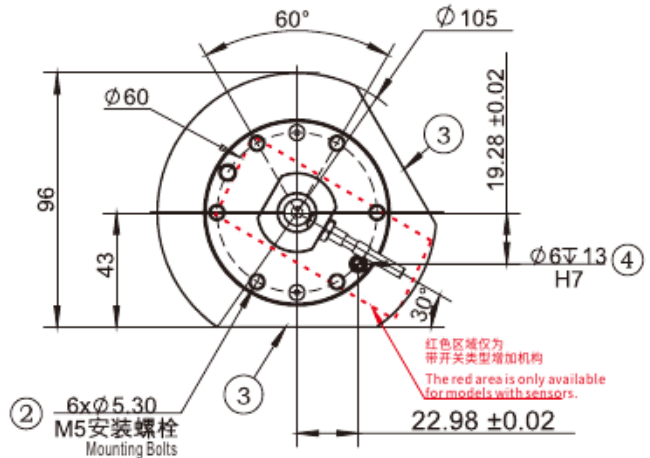
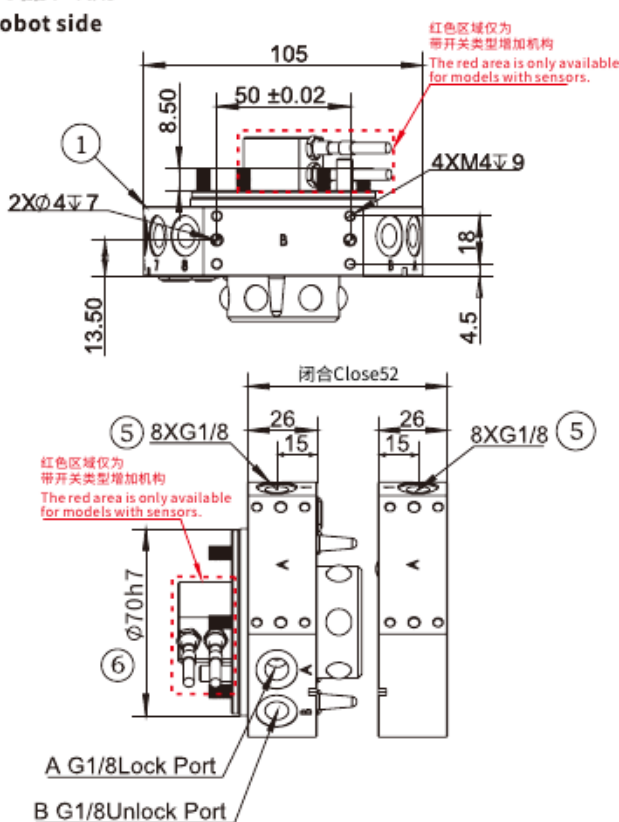

- A. 空气接口锁紧 The air connection locked  
B. 空气接口松开 Air connection released
1. 机器人侧连接 Robot side connection  
2. 螺纹连接用通孔 Threaded through-holes  
3. 选配件安装面 Optional mounting surface  
4. 连接用定位销 Positioning pin  
5. 直通型气孔 Straight through air hole  
6. 中心定位用 Central positioning

# 自动快换 Quick Changer

## 夹具侧 Gripper side

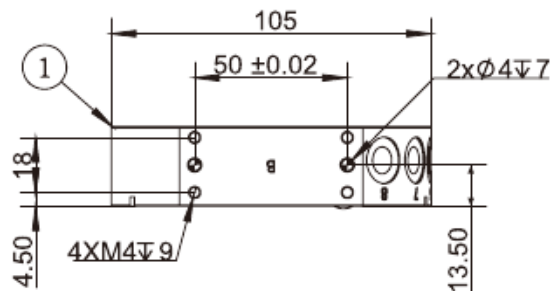
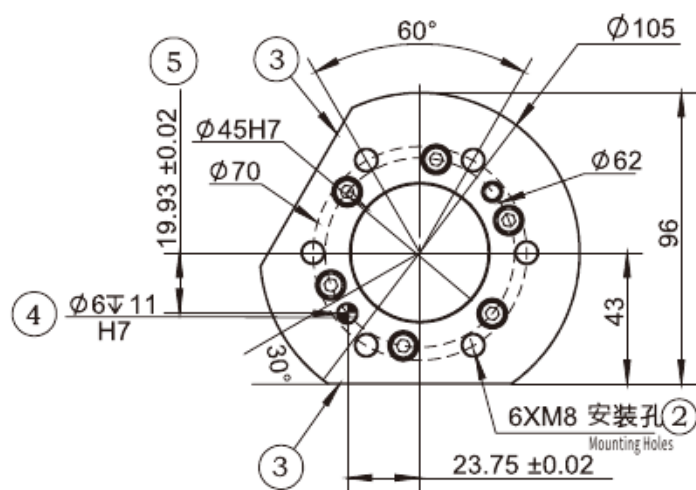

1. 夹具侧连接用 Gripper side connection
2. 螺纹连接用孔 Threaded holes
3. 选配件安装面 Optional mounting surface
4. 连接用定位销 Positioning pin
5. 中心定位用 Central positioning

## 适用模块 Applicable module

### 信号模块 Signal Type

产品名称 Product Name	型号 Model	货号 PN	工作电压 Working Voltage	工作电流 Working Current	接插件 Connector	接插件货号 Connector PN
机器人侧信号模块 Robot side signal module	QCSM-15R2	7.Y00468	24V	2.5A	D-Sub15R2-1000 ①	1.Y10080
夹具侧信号模块 Gripper side signal module	QCSM-15G2	7.Y00469	24V	2.5A	D-Sub15G2-1000 ①	1.Y10081
机器人侧信号模块 Robot side signal module	QCSM-19R	7.Y00954	220V	3A	MS3116F14-19S/-Y ② CMB08E-14-19S(072)SR-B ②	1.Y11420 1.Y11863
机器人侧信号模块 Robot side signal module	QCSM-19R1	7.Y02123	220V	3A	MS3116F14-19S/-Y ② CMB08E-14-19S(072)SR-B ②	1.Y11420 1.Y11863
夹具侧信号模块 Gripper side signal module	QCSM-19G	7.Y00955	220V	3A	MS3116F14-19P/-Y ② CMB08E-14-19P(072)SR-B ②	1.Y11419 1.Y11864
机器人侧信号模块 Robot side signal module	QCSM-26R	7.Y00464	220V	3A	MS3116F16-26S/-Y ② CMB08E-16-26S(072)SR-B ②	1.Y11867 1.Y11865
夹具侧信号模块 Gripper side signal module	QCSM-26G	7.Y00465	220V	3A	MS3116F16-26P/-Y ② CMB08E-16-26P(072)SR-B ②	1.Y11369 1.Y11866
夹具侧信号模块 Gripper side signal module	QCSM-21/26G	7.Y02117	220V	3A	MS3116F16-26P/-Y ② CMB08E-16-26P(072)SR-B ②	1.Y11369 1.Y11866
机器人侧信号模块 Robot side signal module	QCSM-32R	7.Y02095	220V	3A	MS3116F22-36S ② MS3118F22-36S ②	1.Y13392 1.Y13393
夹具侧信号模块 Gripper side signal module	QCSM-32G	7.Y02096	220V	3A	MS3116F22-36P ② MS3118F22-36P ②	1.Y13394 1.Y13395
机器人侧贴面信号模块 Robot side Surface Mount Signal Module	QCSM-TSR2-SP(SN)	7.Y03882/7.Y03902	-	-	-	-
夹具侧贴面信号模块 Gripper side Surface Mount Signal Module	QCSM-TSG2	7.Y03883	-	-	-	-

① 连接线缆材长为1米 The cable's length is 1 meter

② 仅接头, 不含线材 Joint only, no wire

## 适用模块

### Applicable module

### 强电模块

#### Power Module

产品名称 Product Name	型号 Model	货号 PN	工作电压 Working Voltage	工作电流 Working Current	接插件 Connector	接插件货号 Connector PN
机器人侧强电模块 Robot side power module	QCHFME14-C1R	7.Y02003	1.4KV	5A	-	-
夹具侧强电模块 Gripper side power module	QCHFME14-C1G	7.Y02004	1.4KV	5A	-	-
机器人侧强电模块 Robot side power module	QCSM-08R	7.Y00477	380V	20A	3108A22-08S <sup>②</sup>	1.Y10710
夹具侧强电模块 Gripper side power module	QCSM-08G	7.Y00478	380V	20A	3108A22-08P <sup>②</sup>	1.Y10711

② 仅接头, 不含线材 Joint only, no wire

### 通讯模块

#### Communication Module

产品名称 Product Name	型号 Model	货号 PN
机器人侧通讯模块 Robot side communication module	QCSM-05G7/8-04M12-10R	7.Y02118
夹具侧通讯模块 Gripper side communication module	QCSM-05G7/8-04M12-10G	7.Y02119
机器人侧通讯模块 Robot side communication module	QCSM-RJ45-06R	7.Y02007
夹具侧通讯模块 Gripper side communication module	QCSM-RJ45-06G	7.Y02008
机器人侧通讯模块 Robot side communication module	QCSM-05G7/8-04G7/8-10R	7.Y02115
夹具侧通讯模块 Gripper side communication module	QCSM-05G7/8-04G7/8-10G	7.Y02075

### 伺服模块

#### Servo Module

产品名称 Product Name	型号 Model	货号 PN
机器人侧伺服模块 Robot side servo module	QCSM-12R	7.Y02082
夹具侧伺服模块 Gripper side servo module	QCSM-12G	7.Y02083
机器人侧伺服模块 Robot side servo module	QCSM-08R1	7.Y02080
夹具侧伺服模块 Gripper side servo module	QCSM-08G1	7.Y02081
机器人侧伺服模块 Robot side servo module	QCSM-06/11R	7.Y02673
夹具侧伺服模块 Gripper side servo module	QCSM-06/11G	7.Y02674
机器人侧伺服模块 Robot side servo module	QCSM-06/11R1	7.Y02675
夹具侧伺服模块 Gripper side servo module	QCSM-06/11G1	7.Y02676

### 气路模块

#### Pneumatic Module

产品名称 Product Name	型号 Model	货号 PN	气路 Gas path	螺纹孔 Threaded Hole
机器人侧气路模块 Robot side pneumatic module	QCAM-06G18R	7.Y01015	6	G1/8
夹具侧气路模块 Gripper side pneumatic module	QCAM-06G18G	7.Y01016	6	G1/8
机器人侧气路模块 Robot side pneumatic module	QCAM-06G18R-E	7.Y01018	6	G1/8
夹具侧气路模块 Gripper side pneumatic module	QCAM-06G18G-E	7.Y01019	6	G1/8
机器人侧气路模块-自密封 Robot side pneumatic module self-sealing	QCAM-06G18R-F	7.Y02005	6	G1/8
夹具侧气路模块-自密封 Gripper side pneumatic module self-sealing	QCAM-06G18G-F	7.Y02006	6	G1/8

### 水气模块

#### Water-Pneumatic Module

产品名称 Product Name	型号 Model	货号 PN
机器人侧水气模块 Robot side water-pneumatic module	QCWM-02R	7.Y02049
夹具侧水气模块 Gripper side water-pneumatic module	QCWM-02G	7.Y02050

Profile, SUS Tube  
型材、钢管

Stents Module  
支架模组

Quick Changer  
快换

Grip Module  
夹具组件

Air Blipper  
气动剪刀

Vacuum Module  
真空组件

Accessory Components  
附件

# 自动快换 Quick Changer

## QCA-50



机器人侧  
Robot side



夹具侧  
Gripper side



机器人侧带开关  
Robot side strap switch

货号(PN)	8.Y00349
型号(Model)	QCA-50R

货号(PN)	8.Y00350
型号(Model)	QCA-50G

货号(PN)	8.Y00349-SP	8.Y00349-SN
型号(Model)	QCA-50R-SP	QCA-50R-SN
信号检测类别 Signal Detection Category	PNP	NPN

### 产品参数

#### Parameter

- 1.最大负载: 50 kg
- 2.锁紧力@80Psi (5.5Bar): 4600N
- 3.静态承载力矩 (X&Y): 165Nm
- 4.静态承载力矩 (Z): 226 Nm
- 5.位置重复精度 (X,Y&Z):  $\pm 0.015$  mm
- 6.机器人侧带开关重量: 1.22kg
- 7.机器人侧重量: 1.1 kg
- 8.夹具侧重量: 0.6 kg
- 9.最大允许角偏移:  $\pm 1^\circ$
- 10.直通型气孔尺寸(数量): (9) 1/8

1. Max payload: 50kg
2. Locking force@80Psi (5.5Bar): 4600 N
3. Static Load torque (X&Y): 165 Nm
4. Static Load torque (Z): 226 Nm
5. Repeatability accuracy (X, Y&Z):  $\pm 0.015$  mm
6. Robot side's strap switch weight: 1.22 kg
7. Robot side's weight: 1.1 kg
8. Gripper side's weight: 0.6 kg
9. Maximum allowable angle deviation:  $\pm 1^\circ$
10. Size of straight air hole (quantity): (9) 1/8

### 机器人侧

#### Robot side

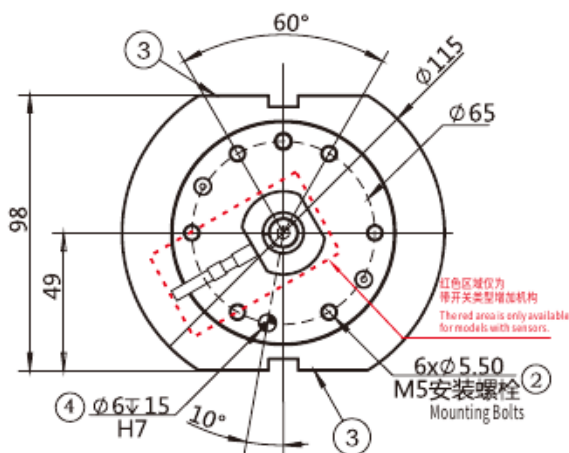
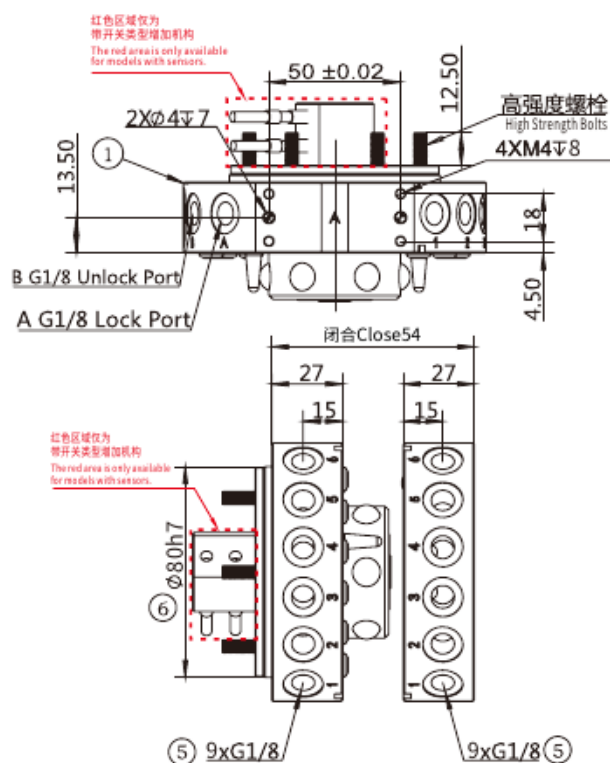

- A. 空气接口锁紧 The air connection locked
  - B. 空气接口松开 Air connection released
1. 机器人侧连接 Robot side connection
  2. 螺纹连接用通孔 Threaded through-holes
  3. 选配件安装面 Optional mounting surface
  4. 连接用定位销 Positioning pin
  5. 直通型气孔 Straight through air hole
  6. 中心定位用 Central positioning

# 自动快换 Quick Changer

## 夹具侧 Gripper side

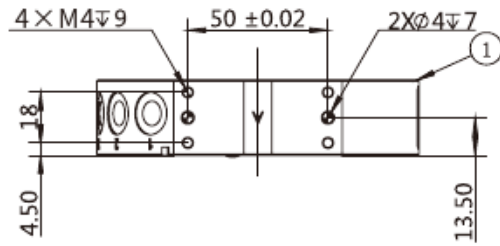
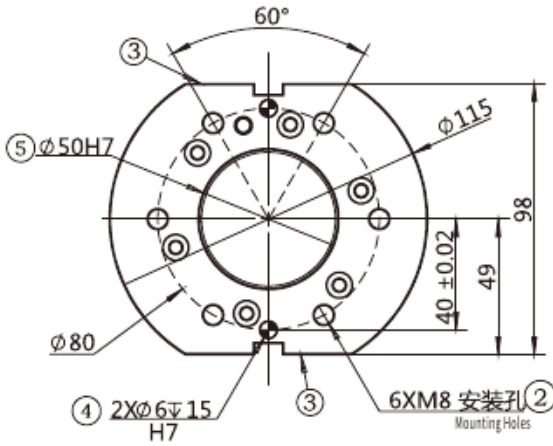

1. 夹具侧连接用 Gripper side connection
2. 螺纹连接用孔 Threaded holes
3. 选配件安装面 Optional mounting surface
4. 连接用定位销 Positioning pin
5. 中心定位用 Central positioning

# 适用模块 Applicable module

## 信号模块 Signal Type

产品名称 Product Name	型号 Model	货号 PN	工作电压 Working Voltage	工作电流 Working Current	接插件 Connector	接插件货号 Connector PN
机器人侧信号模块 Robot side signal module	QCSM-15R2	7.Y00468	24V	2.5A	D-Sub15R2-1000 ①	1.Y10080
夹具侧信号模块 Gripper side signal module	QCSM-15G2	7.Y00469	24V	2.5A	D-Sub15G2-1000 ①	1.Y10081
机器人侧信号模块 Robot side signal module	QCSM-19R	7.Y00954	220V	3A	MS3116F14-19S/-Y ②	1.Y11420
机器人侧信号模块 Robot side signal module	QCSM-19R1	7.Y02123	220V	3A	CMB08E-14-19S(072)SR-B ②	1.Y11863
机器人侧信号模块 Robot side signal module	QCSM-19R1	7.Y02123	220V	3A	MS3116F14-19S/-Y ②	1.Y11420
机器人侧信号模块 Robot side signal module	QCSM-19R1	7.Y02123	220V	3A	CMB08E-14-19S(072)SR-B ②	1.Y11863
夹具侧信号模块 Gripper side signal module	QCSM-19G	7.Y00955	220V	3A	MS3116F14-19P/-Y ②	1.Y11419
夹具侧信号模块 Gripper side signal module	QCSM-19G	7.Y00955	220V	3A	CMB08E-14-19P(072)SR-B ②	1.Y11864
机器人侧信号模块 Robot side signal module	QCSM-26R	7.Y00464	220V	3A	MS3116F16-26S/-Y ②	1.Y11867
机器人侧信号模块 Robot side signal module	QCSM-26R	7.Y00464	220V	3A	CMB08E-16-26S(072)SR-B ②	1.Y11865
夹具侧信号模块 Gripper side signal module	QCSM-26G	7.Y00465	220V	3A	MS3116F16-26P/-Y ②	1.Y11369
夹具侧信号模块 Gripper side signal module	QCSM-26G	7.Y00465	220V	3A	CMB08E-16-26P(072)SR-B ②	1.Y11866
夹具侧信号模块 Gripper side signal module	QCSM-21/26G	7.Y02117	220V	3A	MS3116F16-26P/-Y ②	1.Y11369
夹具侧信号模块 Gripper side signal module	QCSM-21/26G	7.Y02117	220V	3A	CMB08E-16-26P(072)SR-B ②	1.Y11866
机器人侧信号模块 Robot side signal module	QCSM-32R	7.Y02095	220V	3A	MS3116F22-36S ②	1.Y13392
机器人侧信号模块 Robot side signal module	QCSM-32R	7.Y02095	220V	3A	MS3118F22-36S ②	1.Y13393
夹具侧信号模块 Gripper side signal module	QCSM-32G	7.Y02096	220V	3A	MS3116F22-36P ②	1.Y13394
夹具侧信号模块 Gripper side signal module	QCSM-32G	7.Y02096	220V	3A	MS3118F22-36P ②	1.Y13395
机器人侧贴面信号模块 Robot side Surface-Mount Signal Module	QCSM-TSR2-SP(SN)	7.Y03882/7.Y03902	-	-	-	-
夹具侧贴面信号模块 Gripper side Surface-Mount Signal Module	QCSM-TSG2	7.Y03883	-	-	-	-

① 连接线材长为1米 The cable's length is 1 meter

② 仅接头, 不含线材 Joint only, no wire

Profile、SUS Tube  
型材、钢管

Stents Module  
支架模组

Quick Changer  
快换

Grip Module  
夹具组件

Air Nipper  
气动剪刀

Vacuum Module  
真空组件

Accessory Components  
附件

## 适用模块

### Applicable module

## 强电模块

### Power Module

产品名称 Product Name	型号 Model	货号 PN	工作电压 Working Voltage	工作电流 Working Current	接插件 Connector	接插件货号 Connector PN
机器人侧强电模块 Robot side power module	QCHFME14-C1R	7.Y02003	1.4KV	5A	-	-
夹具侧强电模块 Gripper side power module	QCHFME14-C1G	7.Y02004	1.4KV	5A	-	-
机器人侧强电模块 Robot side power module	QCSM-08R	7.Y00477	380V	20A	3108A22-08S <sup>②</sup>	1.Y10710
夹具侧强电模块 Gripper side power module	QCSM-08G	7.Y00478	380V	20A	3108A22-08P <sup>②</sup>	1.Y10711

② 仅接头, 不含线材 Joint only, no wire

## 通讯模块

### Communication Module

产品名称 Product Name	型号 Model	货号 PN
机器人侧通讯模块 Robot side communication module	QCSM-05G7/8-04M12-10R	7.Y02118
夹具侧通讯模块 Gripper side communication module	QCSM-05G7/8-04M12-10G	7.Y02119
机器人侧通讯模块 Robot side communication module	QCSM-RJ45-06R	7.Y02007
夹具侧通讯模块 Gripper side communication module	QCSM-RJ45-06G	7.Y02008
机器人侧通讯模块 Robot side communication module	QCSM-05G7/8-04G7/8-10R	7.Y02115
夹具侧通讯模块 Gripper side communication module	QCSM-05G7/8-04G7/8-10G	7.Y02075

## 伺服模块

### Servo Module

产品名称 Product Name	型号 Model	货号 PN
机器人侧伺服模块 Robot side servo module	QCSM-12R	7.Y02082
夹具侧伺服模块 Gripper side servo module	QCSM-12G	7.Y02083
机器人侧伺服模块 Robot side servo module	QCSM-08R1	7.Y02080
夹具侧伺服模块 Gripper side servo module	QCSM-08G1	7.Y02081
机器人侧伺服模块 Robot side servo module	QCSM-06/11R	7.Y02673
夹具侧伺服模块 Gripper side servo module	QCSM-06/11G	7.Y02674
机器人侧伺服模块 Robot side servo module	QCSM-06/11R1	7.Y02675
夹具侧伺服模块 Gripper side servo module	QCSM-06/11G1	7.Y02676

## 气路模块

### Pneumatic Module

产品名称 Product Name	型号 Model	货号 PN	气路 Gas path	螺纹孔 Threaded Hole
机器人侧气路模块 Robot side pneumatic module	QCAM-06G18R	7.Y01015	6	G1/8
夹具侧气路模块 Gripper side pneumatic module	QCAM-06G18G	7.Y01016	6	G1/8
机器人侧气路模块 Robot side pneumatic module	QCAM-06G18R-E	7.Y01018	6	G1/8
夹具侧气路模块 Gripper side pneumatic module	QCAM-06G18G-E	7.Y01019	6	G1/8
机器人侧气路模块-自密封 Robot side pneumatic module self-sealing	QCAM-06G18R-F	7.Y02005	6	G1/8
夹具侧气路模块-自密封 Gripper side pneumatic module self-sealing	QCAM-06G18G-F	7.Y02006	6	G1/8

## 水气模块

### Water-Pneumatic Module

产品名称 Product Name	型号 Model	货号 PN
机器人侧水气模块 Robot side water-pneumatic module	QCWM-02R	7.Y02049
夹具侧水气模块 Gripper side water-pneumatic module	QCWM-02G	7.Y02050

Profile- SUS Tube  
型材、钢管

Stents Module  
支架模组

Quick Changer  
快换

Grip Module  
夹具组件

Air Nipper  
气动剪刀

Vacuum Module  
真空组件

Accessory Components  
附件

# 自动快换 Quick Changer

## QCA-S50RS-SN(SP) **NEW**



机器人侧带开关  
Robot side strap switch

货号(PN)	8.Y01307	8.Y01312
型号(Model)	QCA-S50RS-SP	QCA-S50RS-SN
信号检测类别 Signal Detection Category	PNP	NPN

### 产品参数 Parameter

- 1.最大负载: 50 kg
- 2.锁紧力@80Psi (5.5Bar): 5800N
- 3.静态承载力矩 (X&Y): 226Nm
- 4.静态承载力矩 (Z): 226 Nm
- 5.位置重复精度 (X,Y&Z): ±0.015 mm
- 6.机器人侧带开关重量: 1.25 kg
- 7.最大允许角偏移: ±2°
- 8.直通型气孔尺寸(数量): (8) 1/8
- 9.增加弹簧结构 断气后双重安全防护掉落

- 1.Max payload: 50kg
- 2.Locking force@80Psi (5.5Bar): 5800 N
- 3.Static Load torque (X&Y): 226 Nm
- 4.Static Load torque (Z): 226 Nm
- 5.Repeatability accuracy (X, Y&Z): ±0.015 mm
- 6.Robot side's strap switch weight: 1.25 kg
- 7.Maximum allowable angle deviation: ±2°
- 8.Size of straight air hole (quantity): (8) 1/8
- 9.Enhanced spring mechanism Dual safety protection against falling after air supply interruption

### 机器人侧 Robot side

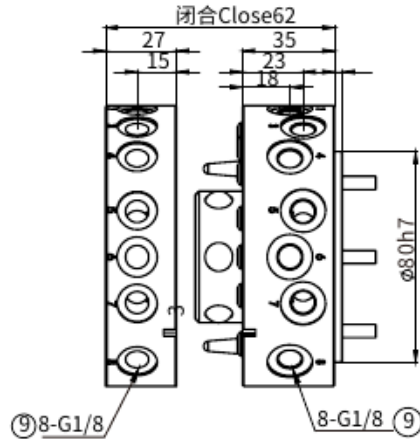
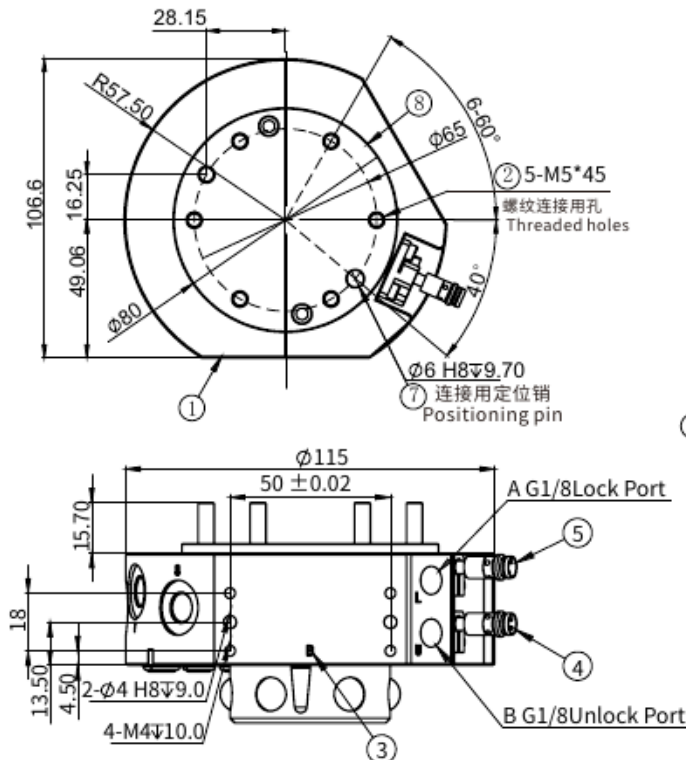

- A. 空气接口锁紧 The air connection locked
  - B. 空气接口松开 Air connection released
1. 机械人侧连接 Robot side connection
  2. 螺纹连接用通孔 Threaded through-holes
  3. 选配件安装面 Optional mounting surface
  4. 监控位置锁紧 Monitoring position locked
  5. 监控位置松开 Monitor position released
  7. 连接用定位销 Positioning pin
  8. 中心定位用 Central positioning
  9. 直通型气孔 Straight through air hole

# 自动快换

Quick Changer

## QCA-S50

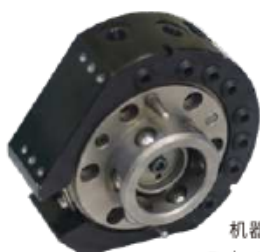

机器人侧  
Robot side

货号(PN)	8.Y00436
型号(Model)	QCA-S50R-SP
信号检测类别 Signal Detection Category	PNP



夹具侧  
Gripper side

货号(PN)	8.Y00405
型号(Model)	QCA-S50G

### 产品参数

#### Parameter

- 1.最大负载: 50 kg
- 2.锁紧力@80Psi (5.5Bar): 5800N
- 3.静态承载力矩 (X&Y): 226Nm
- 4.静态承载力矩 (Z): 226 Nm
- 5.位置重复精度 (X,Y&Z):  $\pm 0.015$  mm
- 6.机器人侧重量: 1.3 kg
- 7.夹具侧重量: 0.6 kg
- 8.最大允许角偏移:  $\pm 2^\circ$
- 9.直通型气孔尺寸(数量): (8) 1/8

- 1.Max payload: 50kg
- 2.Locking force@80Psi (5.5Bar): 5800 N
- 3.Static Load torque (X&Y): 226 Nm
- 4.Static Load torque (Z): 226 Nm
- 5.Repeatability accuracy (X, Y&Z):  $\pm 0.015$  mm
- 6.Robot side's weight: 1.3 kg
- 7.Gripper side's weight: 0.6 kg
- 8.Maximum allowable angle deviation:  $\pm 2^\circ$
- 9.Size of straight air hole (quantity): (8) 1/8

### 机器人侧

#### Robot side

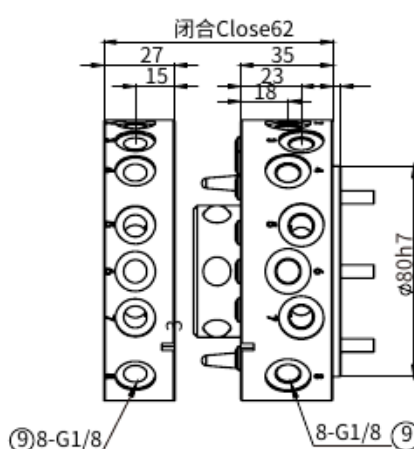
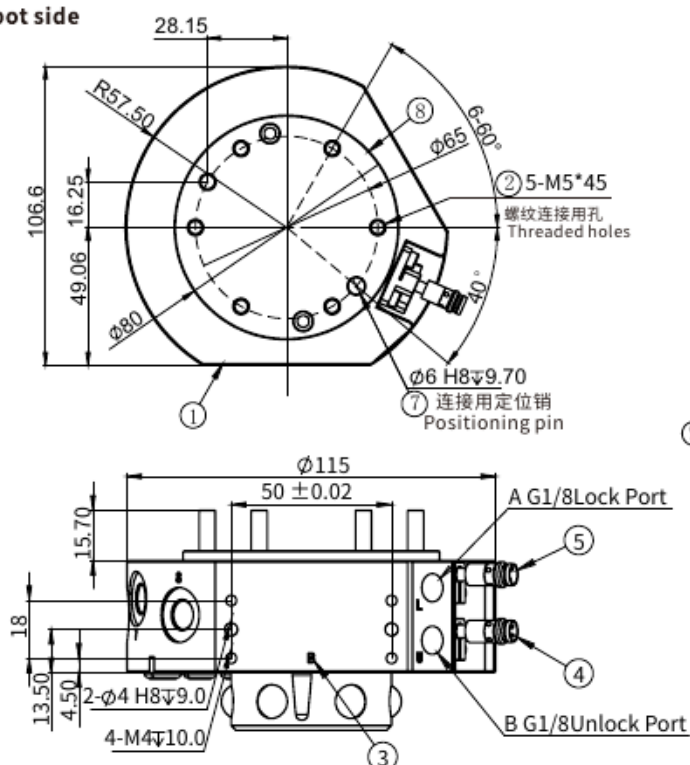

- A. 空气接口锁紧 The air connection locked  
 B. 空气接口松开 Air connection released  
 1. 机械人侧连接 Robot side connection  
 2. 螺纹连接用通孔 Threaded through-holes  
 3. 选配件安装面 Optional mounting surface  
 4. 监控位置锁紧 Monitoring position locked  
 5. 监控位置松开 Monitor position released  
 7. 连接用定位销 Positioning pin  
 8. 中心定位用 Central positioning  
 9. 直通型气孔 Straight through air hole

# 自动快换 Quick Changer

## 夹具侧 Gripper side

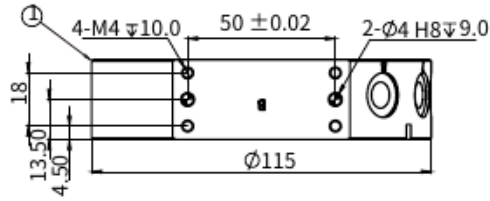
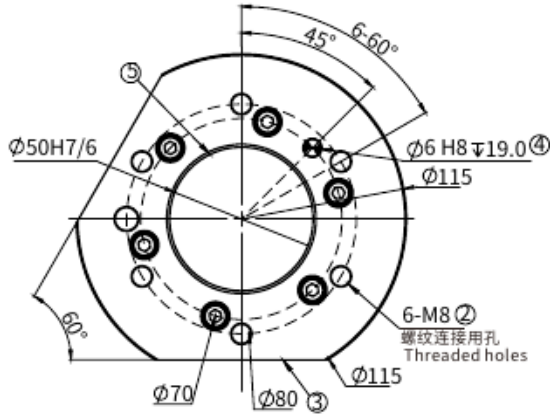

1. 夹具侧连接用 Gripper side connection
2. 螺纹连接用孔 Threaded holes
3. 选配件安装面 Optional mounting surface
4. 连接用定位销 Positioning pin
5. 中心定位用 Central positioning

# 适用模块 Applicable module

## 信号模块 Signal Type

产品名称 Product Name	型号 Model	货号 PN	工作电压 Working Voltage	工作电流 Working Current	接插件 Connector	接插件货号 Connector PN
机器人侧信号模块 Robot side signal module	QCSM-15R2	7.Y00468	24V	2.5A	D-Sub15R2-1000 ①	1.Y10080
夹具侧信号模块 Gripper side signal module	QCSM-15G2	7.Y00469	24V	2.5A	D-Sub15G2-1000 ①	1.Y10081
机器人侧信号模块 Robot side signal module	QCSM-19R	7.Y00954	220V	3A	MS3116F14-19S/-Y ②	1.Y11420
机器人侧信号模块 Robot side signal module	QCSM-19R1	7.Y02123	220V	3A	CMB08E-14-19S(072)SR-B ②	1.Y11863
机器人侧信号模块 Robot side signal module	QCSM-19R1	7.Y02123	220V	3A	MS3116F14-19S/-Y ②	1.Y11420
机器人侧信号模块 Robot side signal module	QCSM-19R1	7.Y02123	220V	3A	CMB08E-14-19S(072)SR-B ②	1.Y11863
夹具侧信号模块 Gripper side signal module	QCSM-19G	7.Y00955	220V	3A	MS3116F14-19P/-Y ②	1.Y11419
夹具侧信号模块 Gripper side signal module	QCSM-19G	7.Y00955	220V	3A	CMB08E-14-19P(072)SR-B ②	1.Y11864
机器人侧信号模块 Robot side signal module	QCSM-26R	7.Y00464	220V	3A	MS3116F16-26S/-Y ②	1.Y11867
机器人侧信号模块 Robot side signal module	QCSM-26R	7.Y00464	220V	3A	CMB08E-16-26S(072)SR-B ②	1.Y11865
夹具侧信号模块 Gripper side signal module	QCSM-26G	7.Y00465	220V	3A	MS3116F16-26P/-Y ②	1.Y11369
夹具侧信号模块 Gripper side signal module	QCSM-26G	7.Y00465	220V	3A	CMB08E-16-26P(072)SR-B ②	1.Y11866
夹具侧信号模块 Gripper side signal module	QCSM-21/26G	7.Y02117	220V	3A	MS3116F16-26P/-Y ②	1.Y11369
夹具侧信号模块 Gripper side signal module	QCSM-21/26G	7.Y02117	220V	3A	CMB08E-16-26P(072)SR-B ②	1.Y11866
机器人侧信号模块 Robot side signal module	QCSM-32R	7.Y02095	220V	3A	MS3116F22-36S ②	1.Y13392
机器人侧信号模块 Robot side signal module	QCSM-32R	7.Y02095	220V	3A	MS3118F22-36S ②	1.Y13393
夹具侧信号模块 Gripper side signal module	QCSM-32G	7.Y02096	220V	3A	MS3116F22-36P ②	1.Y13394
夹具侧信号模块 Gripper side signal module	QCSM-32G	7.Y02096	220V	3A	MS3118F22-36P ②	1.Y13395
机器人侧贴面信号模块 Robot side Surface-Mount Signal Module	QCSM-TSR2-SP(SN)	7.Y03882/7.Y03902	-	-	-	-
夹具侧贴面信号模块 Gripper side Surface-Mount Signal Module	QCSM-TSG2	7.Y03883	-	-	-	-

① 连接线缆材长为1米 The cable's length is 1 meter

② 仅接头, 不含线材 Joint only, no wire

Profile, SUS Tube  
型材、钢管

Stents Module  
支架模组

Quick Changer  
快换

Grip Module  
夹具组件

Air Nipper  
气动剪刀

Vacuum Module  
真空组件

Accessory Components  
附件

## 适用模块

### Applicable module

## 强电模块

### Power Module

产品名称 Product Name	型号 Model	货号 PN	工作电压 Working Voltage	工作电流 Working Current	接插件 Connector	接插件货号 Connector PN
机器人侧强电模块 Robot side power module	QCHFM-E14-C1R	7.Y02003	1.4KV	5A	-	-
夹具侧强电模块 Gripper side power module	QCHFM-E14-C1G	7.Y02004	1.4KV	5A	-	-
机器人侧强电模块 Robot side power module	QCSM-08R	7.Y00477	380V	20A	3108A22-08S <sup>②</sup>	1.Y10710
夹具侧强电模块 Gripper side power module	QCSM-08G	7.Y00478	380V	20A	3108A22-08P <sup>②</sup>	1.Y10711

② 仅接头, 不含线材 Joint only, no wire

## 通讯模块

### Communication Module

产品名称 Product Name	型号 Model	货号 PN
机器人侧通讯模块 Robot side communication module	QCSM-05G7/8-04M12-10R	7.Y02118
夹具侧通讯模块 Gripper side communication module	QCSM-05G7/8-04M12-10G	7.Y02119
机器人侧通讯模块 Robot side communication module	QCSM-RJ45-06R	7.Y02007
夹具侧通讯模块 Gripper side communication module	QCSM-RJ45-06G	7.Y02008
机器人侧通讯模块 Robot side communication module	QCSM-05G7/8-04G7/8-10R	7.Y02115
夹具侧通讯模块 Gripper side communication module	QCSM-05G7/8-04G7/8-10G	7.Y02075

## 伺服模块

### Servo Module

产品名称 Product Name	型号 Model	货号 PN
机器人侧伺服模块 Robot side servo module	QCSM-12R	7.Y02082
夹具侧伺服模块 Gripper side servo module	QCSM-12G	7.Y02083
机器人侧伺服模块 Robot side servo module	QCSM-08R1	7.Y02080
夹具侧伺服模块 Gripper side servo module	QCSM-08G1	7.Y02081
机器人侧伺服模块 Robot side servo module	QCSM-06/11R	7.Y02673
夹具侧伺服模块 Gripper side servo module	QCSM-06/11G	7.Y02674
机器人侧伺服模块 Robot side servo module	QCSM-06/11R1	7.Y02675
夹具侧伺服模块 Gripper side servo module	QCSM-06/11G1	7.Y02676

## 气路模块

### Pneumatic Module

产品名称 Product Name	型号 Model	货号 PN	气路 Gas path	螺纹孔 Threaded Hole
机器人侧气路模块 Robot side pneumatic module	QCAM-06G18R	7.Y01015	6	G1/8
夹具侧气路模块 Gripper side pneumatic module	QCAM-06G18G	7.Y01016	6	G1/8
机器人侧气路模块 Robot side pneumatic module	QCAM-06G18R-E	7.Y01018	6	G1/8
夹具侧气路模块 Gripper side pneumatic module	QCAM-06G18G-E	7.Y01019	6	G1/8
机器人侧气路模块-自密封 Robot side pneumatic module self-sealing	QCAM-06G18R-F	7.Y02005	6	G1/8
夹具侧气路模块-自密封 Gripper side pneumatic module self-sealing	QCAM-06G18G-F	7.Y02006	6	G1/8

## 水气模块

### Water-Pneumatic Module

产品名称 Product Name	型号 Model	货号 PN
机器人侧水气模块 Robot side water-pneumatic module	QCWM-02R	7.Y02049
夹具侧水气模块 Gripper side water-pneumatic module	QCWM-02G	7.Y02050

型材、钢管  
Profile、SUS Tube

支架模组  
Stents Module

快换  
Quick Changer

夹具组件  
Grip Module

气动剪刀  
Air Nipper

真空组件  
Vacuum Module

附件  
Accessory Components

# 自动快换

## Quick Changer

### QCA-100



机器人侧  
Robot side



夹具侧  
Gripper side

货号(PN)	8.Y00362-SP	8.Y00362-SN
型号(Model)	QCA-100R-SP	QCA-100R-SN
信号检测类别 Signal Detection Category	PNP	NPN

货号(PN)	8.Y00363
型号(Model)	QCA-100G

### 产品参数

#### Parameter

- 1.最大负载:100 kg
- 2.锁紧力@80Psi (5.5Bar):12000 N
- 3.静态承载力矩 (X&Y):538 Nm
- 4.静态承载力矩 (Z):720 Nm
- 5.位置重复精度 (X,Y&Z): ± 0.015 mm
- 6.机器人侧重量: 3.6 kg
- 7.夹具侧重量: 1.6 kg
- 8.最大允许角偏移: ±1°
- 9.直通型气孔尺寸(数量): (7) G3/8

- 1.Max payload: 100kg
- 2.Locking force@80Psi (5.5Bar): 12000 N
- 3.Static Load torque (X&Y): 538 Nm
- 4.Static Load torque (Z): 720 Nm
- 5.Repeatability accuracy (X,Y&Z): ±0.015 mm
- 6.Robot side's weight: 3.6 kg
- 7.Gripper side's weight: 1.6 kg
- 8.Maximum allowable angle deviation: ±1°
- 9.Size of straight air hole (quantity): (7) G3/8

### 机器人侧

#### Robot side

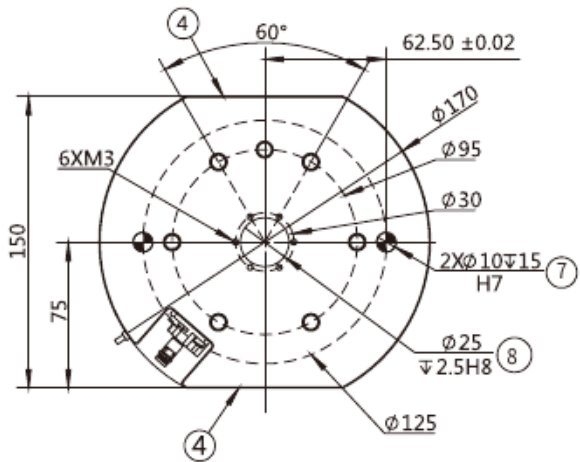
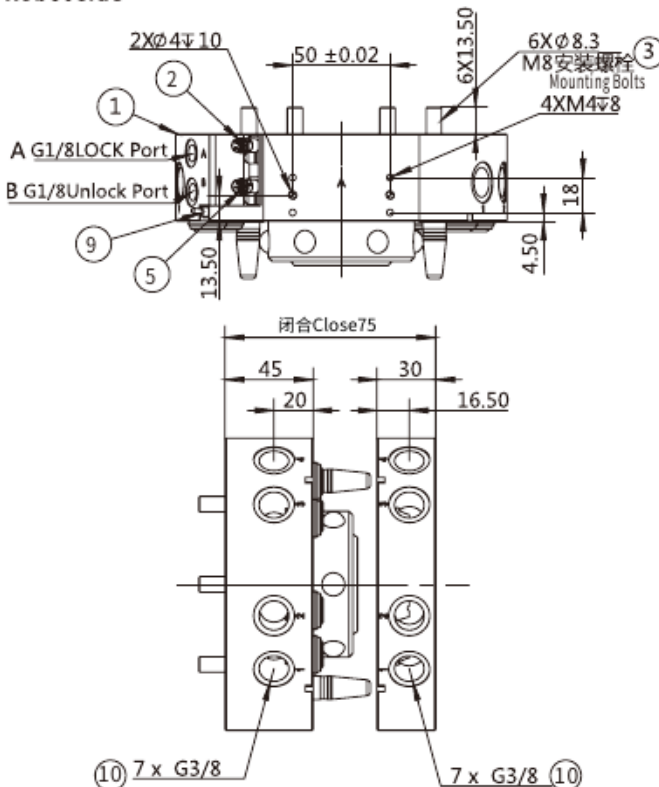

- A. 空气接口锁紧 The air connection locked  
 B. 空气接口松开 Air connection released  
 1. 机器人侧连接 Robot side connection  
 2. 监控位置松开 Monitor position released  
 3. 螺纹连接用通孔 Threaded through-holes  
 4. 选配件安装面 Optional mounting surface  
 5. 监控位置锁紧 Monitoring position locked  
 7. 连接用定位销 Positioning pin  
 8. 中心定位用 Central positioning  
 9. 机器人侧确认接近开关 Proximity switch for robot side confirmation  
 10. 直通型气孔 Straight through air hole

# 自动快换 Quick Changer

## 夹具侧 Gripper side

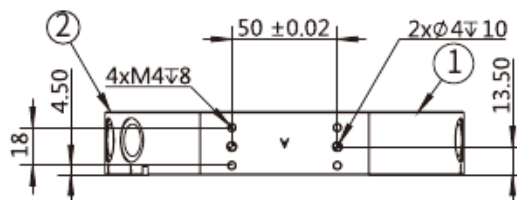
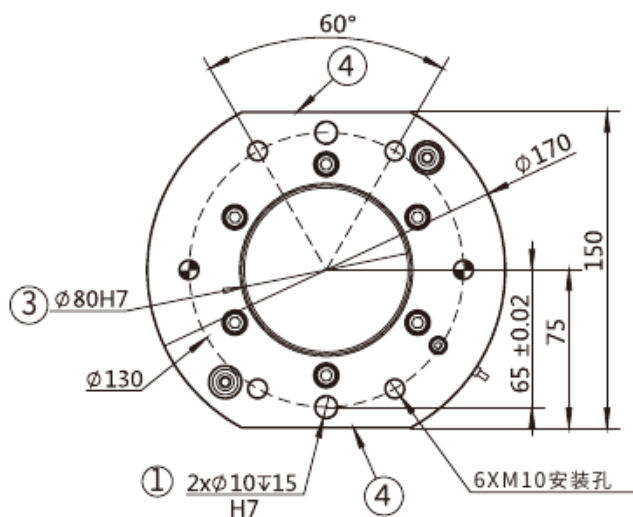

1. 连接用定位销 Positioning pin
2. 夹具侧连接 Gripper side connection
3. 中心定位用 Central positioning
4. 选配件安装面 Optional mounting surface

## 适用模块 Applicable module

### 信号模块 Signal Type

产品名称 Product Name	型号 Model	货号 PN	工作电压 Working Voltage	工作电流 Working Current	接插件 Connector	接插件货号 Connector PN
机器人侧信号模块 Robot side signal module	QCSM-15R2	7.Y00468	24V	2.5A	D-Sub15R2-1000 ①	1.Y10080
夹具侧信号模块 Gripper side signal module	QCSM-15G2	7.Y00469	24V	2.5A	D-Sub15G2-1000 ①	1.Y10081
机器人侧信号模块 Robot side signal module	QCSM-19R	7.Y00954	220V	3A	MS3116F14-19S/-Y ② CMB08E-14-19S(072)SR-B ②	1.Y11420 1.Y11863
机器人侧信号模块 Robot side signal module	QCSM-19R1	7.Y02123	220V	3A	MS3116F14-19S/-Y ② CMB08E-14-19S(072)SR-B ②	1.Y11420 1.Y11863
夹具侧信号模块 Gripper side signal module	QCSM-19G	7.Y00955	220V	3A	MS3116F14-19P/-Y ② CMB08E-14-19P(072)SR-B ②	1.Y11419 1.Y11864
机器人侧信号模块 Robot side signal module	QCSM-26R	7.Y00464	220V	3A	MS3116F16-26S/-Y ② CMB08E-16-26S(072)SR-B ②	1.Y11867 1.Y11865
夹具侧信号模块 Gripper side signal module	QCSM-26G	7.Y00465	220V	3A	MS3116F16-26P/-Y ② CMB08E-16-26P(072)SR-B ②	1.Y11369 1.Y11866
夹具侧信号模块 Gripper side signal module	QCSM-21/26G	7.Y02117	220V	3A	MS3116F16-26P/-Y ② CMB08E-16-26P(072)SR-B ②	1.Y11369 1.Y11866
机器人侧信号模块 Robot side signal module	QCSM-32R	7.Y02095	220V	3A	MS3116F22-36S ② MS3118F22-36S ②	1.Y13392 1.Y13393
夹具侧信号模块 Gripper side signal module	QCSM-32G	7.Y02096	220V	3A	MS3116F22-36P ② MS3118F22-36P ②	1.Y13394 1.Y13395

① 连接线线材长为1米 The cable's length is 1 meter

② 仅接头, 不含线材 Joint only, no wire

Profile- SUS Tube  
型材、钢管

Stents Module  
支架模组

Quick Changer  
快换

Grip Module  
夹具组件

Air Nipper  
气动剪刀

Vacuum Module  
真空组件

Accessory Components  
附件

## 适用模块

### Applicable module

## 强电模块

### Power Module

产品名称 Product Name	型号 Model	货号 PN	工作电压 Working Voltage	工作电流 Working Current	接插件 Connector	接插件货号 Connector PN
机器人侧强电模块 Robot side power module	QCHFME14-C1R	7.Y02003	1.4KV	5A	-	-
夹具侧强电模块 Gripper side power module	QCHFME14-C1G	7.Y02004	1.4KV	5A	-	-
机器人侧强电模块 Robot side power module	QCSM-08R	7.Y00477	380V	20A	3108A22-08S <sup>②</sup>	1.Y10710
夹具侧强电模块 Gripper side power module	QCSM-08G	7.Y00478	380V	20A	3108A22-08P <sup>②</sup>	1.Y10711

② 仅接头, 不含线材 Joint only, no wire

## 通讯模块

### Communication Module

产品名称 Product Name	型号 Model	货号 PN
机器人侧通讯模块 Robot side communication module	QCSM-05G7/8-04M12-10R	7.Y02118
夹具侧通讯模块 Gripper side communication module	QCSM-05G7/8-04M12-10G	7.Y02119
机器人侧通讯模块 Robot side communication module	QCSM-RJ45-06R	7.Y02007
夹具侧通讯模块 Gripper side communication module	QCSM-RJ45-06G	7.Y02008
机器人侧通讯模块 Robot side communication module	QCSM-05G7/8-04G7/8-10R	7.Y02115
夹具侧通讯模块 Gripper side communication module	QCSM-05G7/8-04G7/8-10G	7.Y02075

## 伺服模块

### Servo Module

产品名称 Product Name	型号 Model	货号 PN
机器人侧伺服模块 Robot side servo module	QCSM-12R	7.Y02082
夹具侧伺服模块 Gripper side servo module	QCSM-12G	7.Y02083
机器人侧伺服模块 Robot side servo module	QCSM-08R1	7.Y02080
夹具侧伺服模块 Gripper side servo module	QCSM-08G1	7.Y02081
机器人侧伺服模块 Robot side servo module	QCSM-06/11R	7.Y02673
夹具侧伺服模块 Gripper side servo module	QCSM-06/11G	7.Y02674
机器人侧伺服模块 Robot side servo module	QCSM-06/11R1	7.Y02675
夹具侧伺服模块 Gripper side servo module	QCSM-06/11G1	7.Y02676

## 气路模块

### Pneumatic Module

产品名称 Product Name	型号 Model	货号 PN	气路 Gas path	螺纹孔 Threaded Hole
机器人侧气路模块 Robot side pneumatic module	QCAM-06G18R	7.Y01015	6	G1/8
夹具侧气路模块 Gripper side pneumatic module	QCAM-06G18G	7.Y01016	6	G1/8
机器人侧气路模块 Robot side pneumatic module	QCAM-06G18R-E	7.Y01018	6	G1/8
夹具侧气路模块 Gripper side pneumatic module	QCAM-06G18G-E	7.Y01019	6	G1/8
机器人侧气路模块 Robot side pneumatic module	QCAM-10M5R	7.Y01053	10	M5
夹具侧气路模块 Gripper side pneumatic module	QCAM-10M5G	7.Y01054	10	M5

产品名称 Product Name	型号 Model	货号 PN	气路 Gas path	螺纹孔 Threaded Hole
机器人侧气路模块-自密封 Robot side pneumatic module self-sealing	QCAM-06G18R-F	7.Y02005	6	G1/8
夹具侧气路模块-自密封 Gripper side pneumatic module self-sealing	QCAM-06G18G-F	7.Y02006	6	G1/8
机器人侧气路模块 Robot side pneumatic module	QCAM-04G38R	7.Y02043	4	G3/8
夹具侧气路模块 Gripper side pneumatic module	QCAM-04G38G	7.Y02044	4	G3/8

## 水气模块

### Water-Pneumatic Module

产品名称 Product Name	型号 Model	货号 PN
机器人侧水气模块 Robot side water-pneumatic module	QCWM-02R	7.Y02049
夹具侧水气模块 Gripper side water-pneumatic module	QCWM-02G	7.Y02050

# 自动快换

Quick Changer

## QCA-S100RS-SN(SP) **NEW**



机器人侧带开关  
Robot side strap switch

货号(PN)	8.Y01308	8.Y01313
型号(Model)	QCA-S100RS-SP	QCA-S100RS-SN
信号检测类别 Signal Detection Category	PNP	NPN

### 产品参数

#### Parameter

- 1.最大负载: 100 kg
- 2.锁紧力@80Psi (5.5Bar): 12000 N
- 3.静态承载力矩 (X&Y): 542 Nm
- 4.静态承载力矩 (Z): 701 Nm
- 5.位置重复精度 (X,Y&Z): ±0.015 mm
- 6.机器人侧带开关重量: 2.5 kg
- 7.最大允许角偏移: ±1°
- 8.直通型气孔尺寸(数量): (5) G3/8
- 9.增加弹簧结构 断气后双重安全防护

- 1.Max payload: 100kg
- 2.Locking force@80Psi (5.5Bar): 12000 N
- 3.Static Load torque (X&Y): 542 Nm
- 4.Static Load torque (Z): 701 Nm
- 5.Repeatability accuracy (X,Y&Z): ±0.015 mm
- 6.Robot side's strap switch weight: 2.5 kg
- 7.Maximum allowable angle deviation: ±1°
- 8.Size of straight air hole (quantity): (5) G3/8
- 9.Enhanced spring mechanism Dual safety protection against falling after air supply interruption

### 机器人侧

#### Robot side

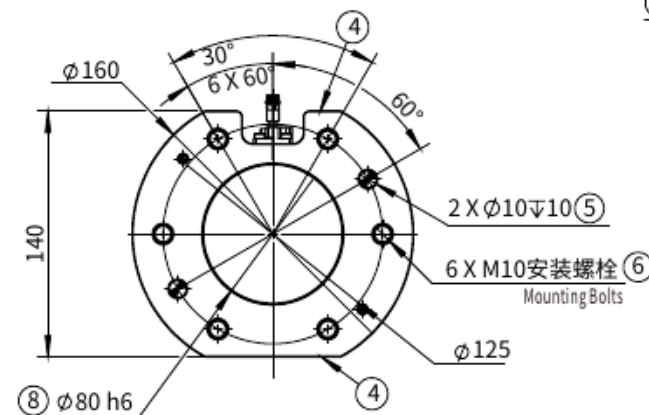
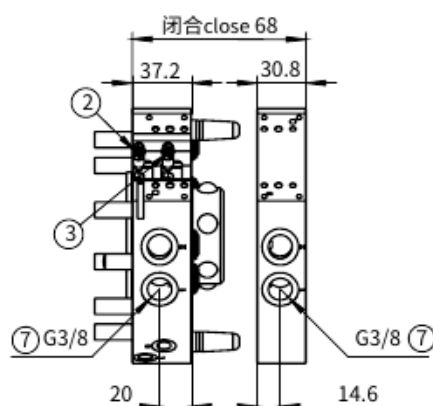
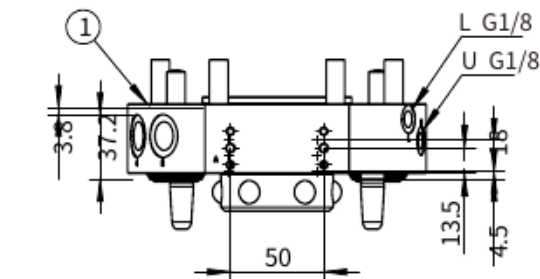

- L.空气接口锁紧 The air connection locked
  - U.空气接口松开 Air connection released
  - 1.机械人侧连接面 Robot side connection
  - 2.监控位置松开 Monitor position released
  - 3.监控位置锁紧 Monitoring position locked
  - 4.选配件安装面 Optional mounting surface
  - 5.连接用定位销孔 Locating pin hole for connection
  - 6.螺纹连接用通孔 Through hole for threaded connection
  - 7.直通型气孔 Straight through air hole
  - 8.中心定位用 Central positioning
- 机器人侧安装孔 Robot side mounting holes  
ISO-9409-1-125-6-M10

Profile- SUS Tube  
型材、钢管

Stents Module  
支架模组

Quick Changer  
快换

Grip Module  
夹具组件

Air Nipper  
气动剪刀

Vacuum Module  
真空组件

Accessory Components  
附件

# 自动快换

## Quick Changer

### QCA-S100



机器人侧  
Robot side



夹具侧  
Gripper side

货号(PN)	8.Y00437
型号(Model)	QCA-S100R-SP
信号检测类别 Signal Detection Category	PNP

货号(PN)	8.Y00426
型号(Model)	QCA-S100G

### 产品参数

#### Parameter

- 1.最大负载: 100 kg
- 2.锁紧力@80Psi (5.5Bar): 12000 N
- 3.静态承载力矩 (X&Y): 542 Nm
- 4.静态承载力矩 (Z): 701 Nm
- 5.位置重复精度 (X,Y&Z):  $\pm 0.015$  mm
- 6.机器人侧重量: 2.3 kg
- 7.夹具侧重量: 1.4 kg
- 8.最大允许角偏移:  $\pm 1^\circ$
- 9.直通型气孔尺寸(数量): (5) G3/8

- 1.Max payload: 100kg
- 2.Locking force@80Psi (5.5Bar): 12000 N
- 3.Static Load torque (X&Y): 542 Nm
- 4.Static Load torque (Z): 701 Nm
- 5.Repeatability accuracy (X,Y&Z):  $\pm 0.015$  mm
- 6.Robot side's weight: 2.3 kg
- 7.Gripper side's weight: 1.4 kg
- 8.Maximum allowable angle deviation:  $\pm 1^\circ$
- 9.Size of straight air hole (quantity): (5) G3/8

### 机器人侧

#### Robot side

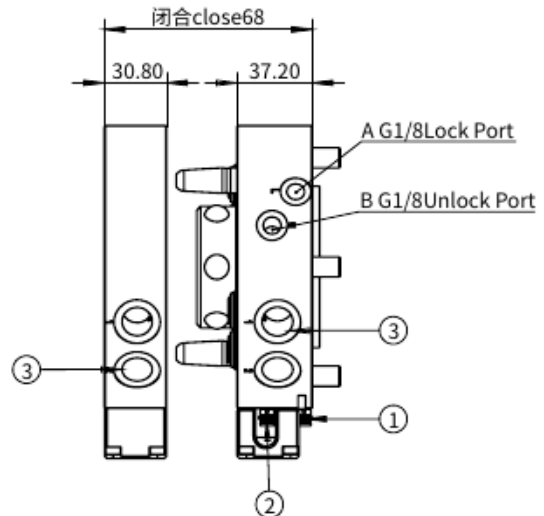
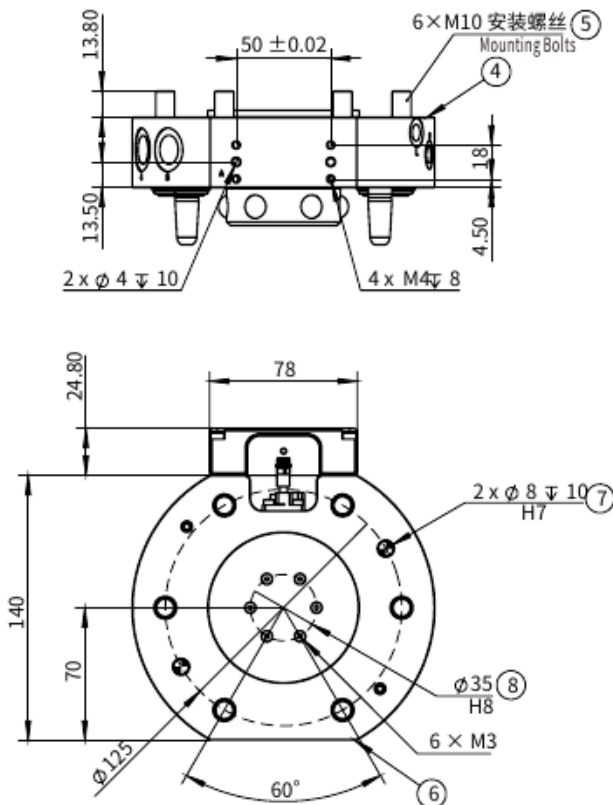

- A. 空气接口锁紧 The air connection locked  
 B. 空气接口松开 Air connection released  
 1. 监控位置锁紧 Monitoring position locked  
 2. 监控位置松开 Monitor position released  
 3. 直通型气孔G3/8 Straight through air hole G3/8  
 4. 机械人侧连接 Robot side connection  
 5. 机器人侧安装螺丝M10 Robot Side Mounting Screws M10  
 6. 选配件安装面 Optional mounting surface  
 7. 连接用定位销 Positioning pin  
 8. 中心定位用 Central positioning

# 自动快换 Quick Changer

## 夹具侧 Gripper side

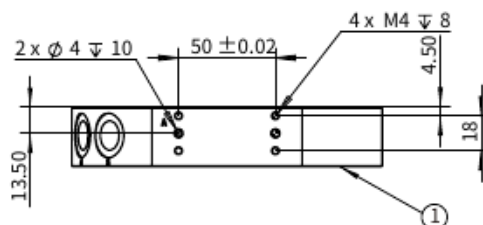
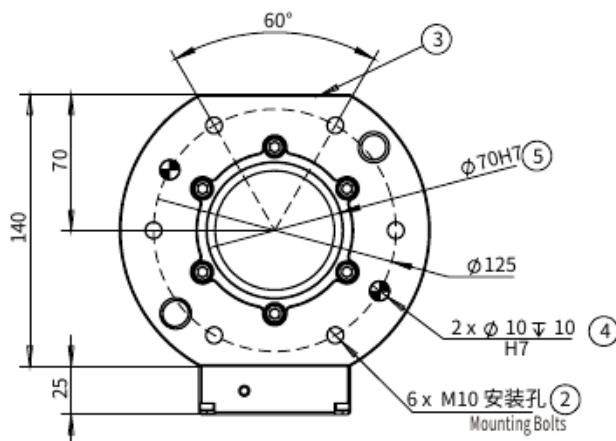

1. 夹具侧连接用 Gripper side connection
2. 螺纹连接用孔 Hole for threaded connection
3. 选配件安装面 Optional mounting surface
4. 连接用定位销 Positioning pin
5. 中心定位用 Central positioning

## 适用模块 Applicable module

### 信号模块 Signal Type

产品名称 Product Name	型号 Model	货号 PN	工作电压 Working Voltage	工作电流 Working Current	接插件 Connector	接插件货号 Connector PN
机器人侧信号模块 Robot side signal module	QCSM-15R2	7.Y00468	24V	2.5A	D-Sub15R2-1000 ①	1.Y10080
夹具侧信号模块 Gripper side signal module	QCSM-15G2	7.Y00469	24V	2.5A	D-Sub15G2-1000 ①	1.Y10081
机器人侧信号模块 Robot side signal module	QCSM-19R	7.Y00954	220V	3A	MS3116F14-19S/-Y ②	1.Y11420
					CMB08E-14-19S(072)SR-B ②	1.Y11863
机器人侧信号模块 Robot side signal module	QCSM-19R1	7.Y02123	220V	3A	MS3116F14-19S/-Y ②	1.Y11420
					CMB08E-14-19S(072)SR-B ②	1.Y11863
夹具侧信号模块 Gripper side signal module	QCSM-19G	7.Y00955	220V	3A	MS3116F14-19P/-Y ②	1.Y11419
					CMB08E-14-19P(072)SR-B ②	1.Y11864
机器人侧信号模块 Robot side signal module	QCSM-26R	7.Y00464	220V	3A	MS3116F16-26S/-Y ②	1.Y11867
					CMB08E-16-26S(072)SR-B ②	1.Y11865
夹具侧信号模块 Gripper side signal module	QCSM-26G	7.Y00465	220V	3A	MS3116F16-26P/-Y ②	1.Y11369
					CMB08E-16-26P(072)SR-B ②	1.Y11866
夹具侧信号模块 Gripper side signal module	QCSM-21/26G	7.Y02117	220V	3A	MS3116F16-26P/-Y ②	1.Y11369
					CMB08E-16-26P(072)SR-B ②	1.Y11866
机器人侧信号模块 Robot side signal module	QCSM-32R	7.Y02095	220V	3A	MS3116F22-36S ②	1.Y13392
					MS3118F22-36S ②	1.Y13393
夹具侧信号模块 Gripper side signal module	QCSM-32G	7.Y02096	220V	3A	MS3116F22-36P ②	1.Y13394
					MS3118F22-36P ②	1.Y13395

① 连接线材长为1米 The cable's length is 1 meter

② 仅接头, 不含线材 Joint only, no wire

## 适用模块

### Applicable module

## 强电模块

### Power Module

产品名称 Product Name	型号 Model	货号 PN	工作电压 Working Voltage	工作电流 Working Current	接插件 Connector	接插件货号 Connector PN
机器人侧强电模块 Robot side power module	QCHFME14-C1R	7.Y02003	1.4KV	5A	-	-
夹具侧强电模块 Gripper side power module	QCHFME14-C1G	7.Y02004	1.4KV	5A	-	-
机器人侧强电模块 Robot side power module	QCSM-08R	7.Y00477	380V	20A	3108A22-08S <sup>②</sup>	1.Y10710
夹具侧强电模块 Gripper side power module	QCSM-08G	7.Y00478	380V	20A	3108A22-08P <sup>②</sup>	1.Y10711

② 仅接头, 不含线材 Joint only, no wire

## 通讯模块

### Communication Module

产品名称 Product Name	型号 Model	货号 PN
机器人侧通讯模块 Robot side communication module	QCSM-05G7/8-04M12-10R	7.Y02118
夹具侧通讯模块 Gripper side communication module	QCSM-05G7/8-04M12-10G	7.Y02119
机器人侧通讯模块 Robot side communication module	QCSM-RJ45-06R	7.Y02007
夹具侧通讯模块 Gripper side communication module	QCSM-RJ45-06G	7.Y02008
机器人侧通讯模块 Robot side communication module	QCSM-05G7/8-04G7/8-10R	7.Y02115
夹具侧通讯模块 Gripper side communication module	QCSM-05G7/8-04G7/8-10G	7.Y02075

## 伺服模块

### Servo Module

产品名称 Product Name	型号 Model	货号 PN
机器人侧伺服模块 Robot side servo module	QCSM-12R	7.Y02082
夹具侧伺服模块 Gripper side servo module	QCSM-12G	7.Y02083
机器人侧伺服模块 Robot side servo module	QCSM-08R1	7.Y02080
夹具侧伺服模块 Gripper side servo module	QCSM-08G1	7.Y02081
机器人侧伺服模块 Robot side servo module	QCSM-06/11R	7.Y02673
夹具侧伺服模块 Gripper side servo module	QCSM-06/11G	7.Y02674
机器人侧伺服模块 Robot side servo module	QCSM-06/11R1	7.Y02675
夹具侧伺服模块 Gripper side servo module	QCSM-06/11G1	7.Y02676

## 气路模块

### Pneumatic Module

产品名称 Product Name	型号 Model	货号 PN	气路 Gas path	螺纹孔 Threaded Hole
机器人侧气路模块 Robot side pneumatic module	QCAM-06G18R	7.Y01015	6	G1/8
夹具侧气路模块 Gripper side pneumatic module	QCAM-06G18G	7.Y01016	6	G1/8
机器人侧气路模块 Robot side pneumatic module	QCAM-06G18R-E	7.Y01018	6	G1/8
夹具侧气路模块 Gripper side pneumatic module	QCAM-06G18G-E	7.Y01019	6	G1/8
机器人侧气路模块 Robot side pneumatic module	QCAM-10M5R	7.Y01053	10	M5
夹具侧气路模块 Gripper side pneumatic module	QCAM-10M5G	7.Y01054	10	M5

产品名称 Product Name	型号 Model	货号 PN	气路 Gas path	螺纹孔 Threaded Hole
机器人侧气路模块 Robot side pneumatic module	QCAM-14M5R	7.Y01055	14	M5
夹具侧气路模块 Gripper side pneumatic module	QCAM-14M5G	7.Y01056	14	M5
机器人侧气路模块-自密封 Robot side pneumatic module self-sealing	QCAM-06G18R-F	7.Y02005	6	G1/8
夹具侧气路模块-自密封 Gripper side pneumatic module self-sealing	QCAM-06G18G-F	7.Y02006	6	G1/8
机器人侧气路模块 Robot side pneumatic module	QCAM-04G38R	7.Y02043	4	G3/8
夹具侧气路模块 Gripper side pneumatic module	QCAM-04G38G	7.Y02044	4	G3/8

## 水气模块

### Water-Pneumatic Module

产品名称 Product Name	型号 Model	货号 PN
机器人侧水气模块 Robot side water pneumatic module	QCWM-02R	7.Y02049
夹具侧水气模块 Gripper side water pneumatic module	QCWM-02G	7.Y02050

# 自动快换

Quick Changer

## QCA-S150RS-SN(SP) NEW



机器人侧带开关  
Robot side strap switch

货号(PN)	8.Y01309	8.Y01314
型号(Model)	QCA-S150RS-SP	QCA-S150RS-SN
信号检测类别 Signal Detection Category	PNP	NPN

### 产品参数

#### Parameter

- 1.最大负载: 150kg
- 2.锁紧力@80Psi (5.5Bar): 12000 N
- 3.静态承载力矩 (X&Y): 784 Nm
- 4.静态承载力矩 (Z): 784 Nm
- 5.位置重复精度 (X,Y&Z): ±0.015 mm
- 6.机器人侧带开关重量: 4.6 kg
- 7.最大允许角偏移: ±1°
- 8.直通型气孔尺寸 (数量):(8) 3/8
- 9.增加弹簧结构 断气后双重安全防护掉落

- 1.Max payload: 150kg
- 2.Locking force@80Psi (5.5Bar): 12000 N
- 3.Static Load torque (X&Y): 784 Nm
- 4.Static Load torque (Z): 784Nm
- 5.Repeatability accuracy (X,Y&Z): ±0.015 mm
- 6.Robot side's strap switch weight: 4.6 kg
- 7.Maximum allowable angle deviation: ±1°
- 8.Size of straight airhole (quantity):(8) 3/8
- 9.Enhanced spring mechanism Dual safety protection against falling after air supply interruption

### 机器人侧

#### Robot side

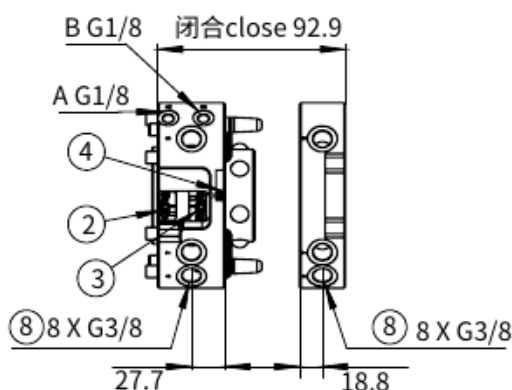
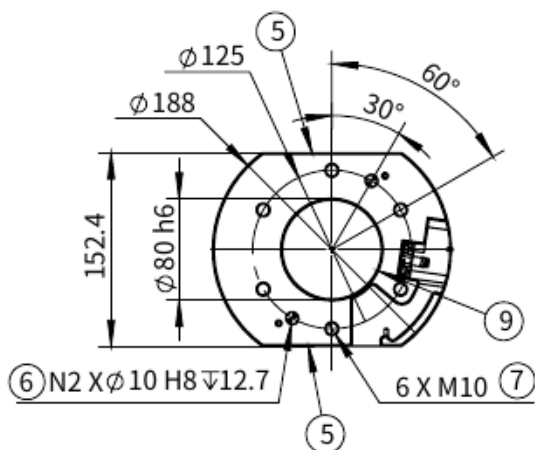
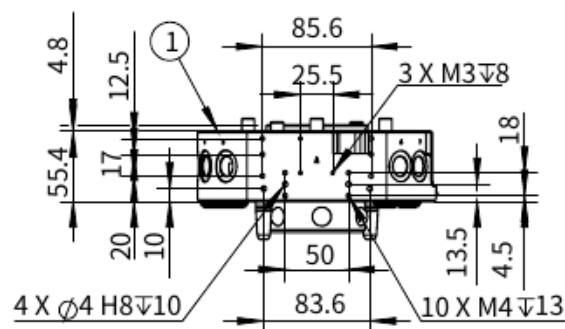

- L. 空气接口锁紧 The air connection locked
  - U. 空气接口松开 Air connection released
  - 1. 机器人侧连接面 Robot side connection
  - 2. 监控位置松开 Monitor position released
  - 3. 监控位置锁紧 Monitoring position locked
  - 4. 机器人侧确认接近开关 Robot side proximity switch confirmation
  - 5. 选配件安装面 Optional mounting surface
  - 6. 连接用定位销孔 Locating pin hole for connection
  - 7. 螺纹连接用通孔 Through hole for threaded connection
  - 8. 直通型气孔 Straight through air hole
  - 9. 安装用定位环 Installation positioning ring
- 机器人侧安装孔 Robot side mounting holes  
ISO-9409-1-125-6-M10

# 自动快换

## Quick Changer

### QCA-S150



机器人侧  
Robot side

货号(PN)	8.Y01013
型号(Model)	QCA-S150R-SP
信号检测类别 Signal Detection Category	PNP

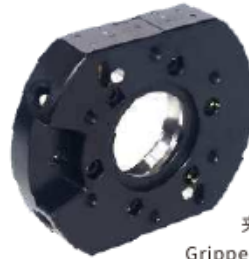

夹具侧  
Gripper side

货号(PN)	8.Y01014
型号(Model)	QCA-S150G

### 产品参数

#### Parameter

- 1.最大负载: 150kg
- 2.锁紧力@80Psi (5.5Bar): 12000 N
- 3.静态承载力矩 (X&Y): 784 Nm
- 4.静态承载力矩 (Z): 784 Nm
- 5.位置重复精度 (X,Y&Z):  $\pm 0.015$  mm
- 6.机器人侧重量: 4 kg
- 7.夹具侧重量: 2.2 kg
- 8.最大允许角偏移:  $\pm 1^\circ$
- 9.直通型气孔尺寸 (数量):(8) 3/8

- 1.Max payload: 150kg
- 2.Locking force@80Psi (5.5Bar): 12000 N
- 3.Static Load torque (X&Y): 784 Nm
- 4.Static Load torque (Z): 784 Nm
- 5.Repeatability accuracy (X,Y&Z):  $\pm 0.015$  mm
- 6.Robot side's weight: 4 kg
- 7.Gripper side's weight: 2.2 kg
- 8.Maximum allowable angle deviation:  $\pm 1^\circ$
- 9.Size of straight air hole (quantity):(8) 3/8

### 机器人侧

#### Robot side

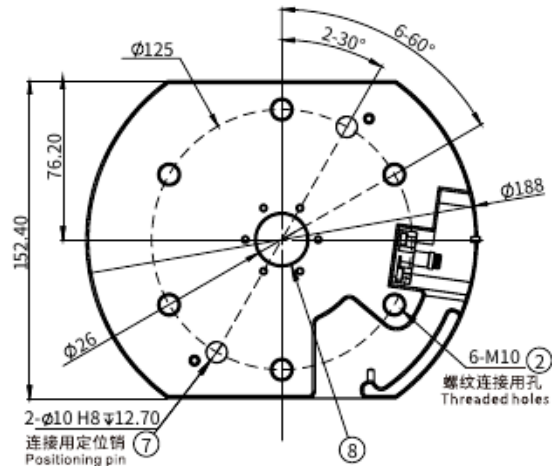
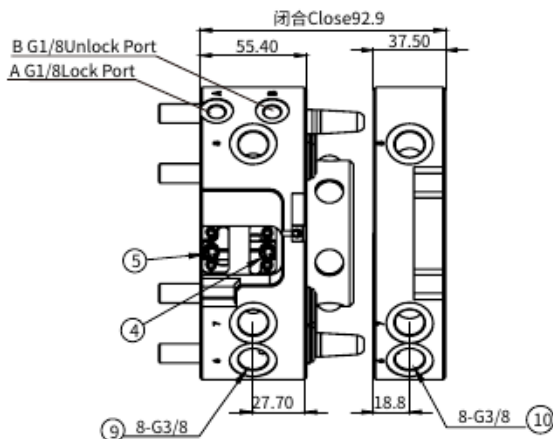
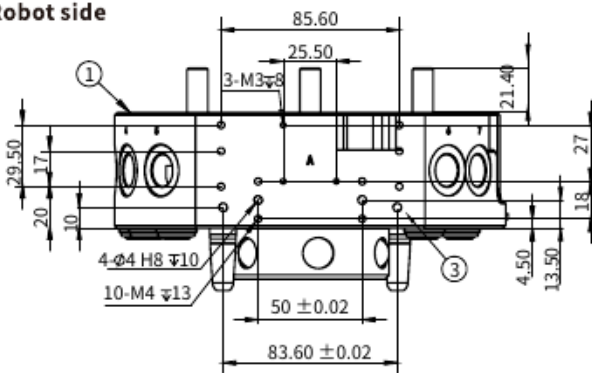

- A. 空气接口锁紧 The air connection locked  
B. 空气接口松开 Air connection released
1. 机器人侧连接 Robot side connection
  2. 螺纹连接用通孔 Threaded through-holes
  3. 选配件安装面 Optional mounting surface
  4. 监控位置锁紧 Monitoring position locked
  5. 监控位置松开 Monitor position released
  7. 连接用定位销 Positioning pin
  8. 中心定位用 Central positioning
  9. 直通型气孔 Straight through air hole

# 自动快换 Quick Changer

## 夹具侧 Gripper side

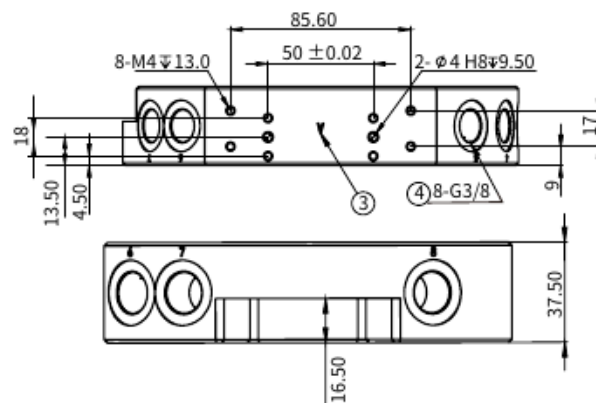
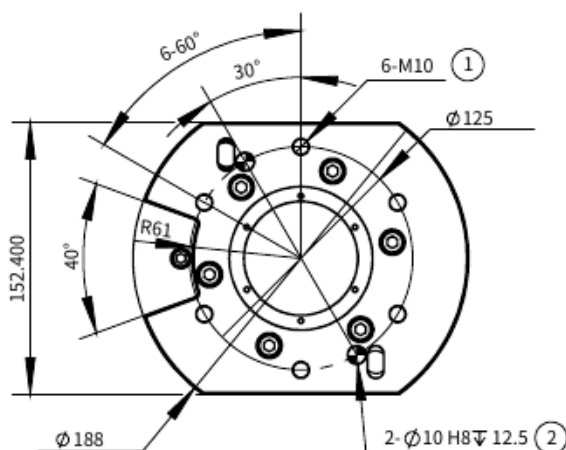

1. 安装固定螺丝孔 Install the fixing screw hole
2. 安装固定销孔 Install the fixed pin hole
3. 模块安装面A Module mounting surface A
4. 通气孔 Air Vents
5. 模块安装面B Module mounting surface B

## 适用模块 Applicable module

### 信号模块 Signal Type

产品名称 Product Name	型号 Model	货号 PN	工作电压 Working Voltage	工作电流 Working Current	接插件 Connector	接插件货号 Connector PN
机器人侧信号模块 Robot side signal module	QCSM-15R2	7.Y00468	24V	2.5A	D-Sub15R2-1000 ①	1.Y10080
夹具侧信号模块 Gripper side signal module	QCSM-15G2	7.Y00469	24V	2.5A	D-Sub15G2-1000 ①	1.Y10081
机器人侧信号模块 Robot side signal module	QCSM-19R	7.Y00954	220V	3A	MS3116F14-19S/-Y ②	1.Y11420
机器人侧信号模块 Robot side signal module	QCSM-19R1	7.Y02123	220V	3A	CMB08E-14-19S(072)SR-B ②	1.Y11863
夹具侧信号模块 Gripper side signal module	QCSM-19G	7.Y00955	220V	3A	MS3116F14-19S/-Y ②	1.Y11420
夹具侧信号模块 Gripper side signal module	QCSM-19G	7.Y00955	220V	3A	CMB08E-14-19P(072)SR-B ②	1.Y11864
机器人侧信号模块 Robot side signal module	QCSM-26R	7.Y00464	220V	3A	MS3116F16-26S/-Y ②	1.Y11867
夹具侧信号模块 Gripper side signal module	QCSM-26G	7.Y00465	220V	3A	CMB08E-16-26S(072)SR-B ②	1.Y11865
夹具侧信号模块 Gripper side signal module	QCSM-21/26G	7.Y02117	220V	3A	MS3116F16-26P/-Y ②	1.Y11369
夹具侧信号模块 Gripper side signal module	QCSM-21/26G	7.Y02117	220V	3A	CMB08E-16-26P(072)SR-B ②	1.Y11866
机器人侧信号模块 Robot side signal module	QCSM-32R	7.Y02095	220V	3A	MS3116F22-36S ②	1.Y13392
机器人侧信号模块 Robot side signal module	QCSM-32R	7.Y02095	220V	3A	MS3118F22-36S ②	1.Y13393
夹具侧信号模块 Gripper side signal module	QCSM-32G	7.Y02096	220V	3A	MS3116F22-36P ②	1.Y13394
夹具侧信号模块 Gripper side signal module	QCSM-32G	7.Y02096	220V	3A	MS3118F22-36P ②	1.Y13395

① 连接线缆材长为1米 The cable's length is 1 meter

② 仅接头, 不含线材 Joint only, no wire

Profile- SUS Tube

Stents Module

Quick Changer

Gripper Module

Air Nipper

Vacuum Module

Accessory Components

## 适用模块

### Applicable module

## 强电模块

### Power Module

产品名称 Product Name	型号 Model	货号 PN	工作电压 Working Voltage	工作电流 Working Current	接插件 Connector	接插件货号 Connector PN
机器人侧强电模块 Robot side power module	QCHFME14-C1R	7.Y02003	1.4KV	5A	-	-
夹具侧强电模块 Gripper side power module	QCHFME14-C1G	7.Y02004	1.4KV	5A	-	-
机器人侧强电模块 Robot side power module	QCSM-08R	7.Y00477	380V	20A	3108A22-08S <sup>②</sup>	1.Y10710
夹具侧强电模块 Gripper side power module	QCSM-08G	7.Y00478	380V	20A	3108A22-08P <sup>②</sup>	1.Y10711

② 仅接头, 不含线材 Joint only, no wire

## 通讯模块

### Communication Module

产品名称 Product Name	型号 Model	货号 PN
机器人侧通讯模块 Robot side communication module	QCSM-05G7/8-04M12-10R	7.Y02118
夹具侧通讯模块 Gripper side communication module	QCSM-05G7/8-04M12-10G	7.Y02119
机器人侧通讯模块 Robot side communication module	QCSM-RJ45-06R	7.Y02007
夹具侧通讯模块 Gripper side communication module	QCSM-RJ45-06G	7.Y02008
机器人侧通讯模块 Robot side communication module	QCSM-05G7/8-04G7/8-10R	7.Y02115
夹具侧通讯模块 Gripper side communication module	QCSM-05G7/8-04G7/8-10G	7.Y02075

## 伺服模块

### Servo Module

产品名称 Product Name	型号 Model	货号 PN
机器人侧伺服模块 Robot side servo module	QCSM-12R	7.Y02082
夹具侧伺服模块 Gripper side servo module	QCSM-12G	7.Y02083
机器人侧伺服模块 Robot side servo module	QCSM-08R1	7.Y02080
夹具侧伺服模块 Gripper side servo module	QCSM-08G1	7.Y02081
机器人侧伺服模块 Robot side servo module	QCSM-06/11R	7.Y02673
夹具侧伺服模块 Gripper side servo module	QCSM-06/11G	7.Y02674
机器人侧伺服模块 Robot side servo module	QCSM-06/11R1	7.Y02675
夹具侧伺服模块 Gripper side servo module	QCSM-06/11G1	7.Y02676

## 气路模块

### Pneumatic Module

产品名称 Product Name	型号 Model	货号 PN	气路 Gas path	螺纹孔 Threaded Hole
机器人侧气路模块 Robot side pneumatic module	QCAM-01G2R	7.Y03893	-	-
夹具侧气路模块 Gripper side pneumatic module	QCAM-01G2G	7.Y03894	-	-
机器人侧气路模块 Robot side pneumatic module	QCAM-06G18R	7.Y01015	6	G1/8
夹具侧气路模块 Gripper side pneumatic module	QCAM-06G18G	7.Y01016	6	G1/8
机器人侧气路模块 Robot side pneumatic module	QCAM-06G18R-E	7.Y01018	6	G1/8
夹具侧气路模块 Gripper side pneumatic module	QCAM-06G18G-E	7.Y01019	6	G1/8
机器人侧气路模块 Robot side pneumatic module	QCAM-10M5R	7.Y01053	10	M5
夹具侧气路模块 Gripper side pneumatic module	QCAM-10M5G	7.Y01054	10	M5

产品名称 Product Name	型号 Model	货号 PN	气路 Gas path	螺纹孔 Threaded Hole
机器人侧气路模块 Robot side pneumatic module	QCAM-14M5R	7.Y01055	14	M5
夹具侧气路模块 Gripper side pneumatic module	QCAM-14M5G	7.Y01056	14	M5
机器人侧气路模块-自密封 Robot side pneumatic module self-sealing	QCAM-06G18R-F	7.Y02005	6	G1/8
夹具侧气路模块-自密封 Gripper side pneumatic module self-sealing	QCAM-06G18G-F	7.Y02006	6	G1/8
机器人侧气路模块 Robot side pneumatic module	QCAM-04G38R	7.Y02043	4	G3/8
夹具侧气路模块 Gripper side pneumatic module	QCAM-04G38G	7.Y02044	4	G3/8

## 水气模块

### Water-Pneumatic Module

产品名称 Product Name	型号 Model	货号 PN
机器人侧水气模块 Robot side water pneumatic module	QCWM-02R	7.Y02049
夹具侧水气模块 Gripper side water pneumatic module	QCWM-02G	7.Y02050

# 自动快换

Quick Changer

## QCA-200



机器人侧  
Robot side



夹具侧  
Gripper side

货号(PN)	8.Y00272-SP	8.Y00272-SN
型号(Model)	QCA-200R-SP	QCA-200R-SN
信号检测类别 Signal Detection Category	PNP	NPN

货号(PN)	8.Y00357
型号(Model)	QCA-200G

### 产品参数

#### Parameter

- |                              |  |
|------------------------------|--|
| 1.最大负载: 300 kg               | 1.Max payload: 300kg                             |
| 2.锁紧力@80Psi(5.5Bar): 16000 N | 2.Locking force@80Psi(5.5Bar): 16000 N           |
| 3.静态承载力矩(X&Y): 1360 Nm       | 3.Static Load torque (X&Y): 1360 Nm              |
| 4.静态承载力矩(Z): 1130 Nm         | 4.Static Load torque (Z): 1130 Nm                |
| 5.位置重复精度(X,Y&Z): ±0.015 mm   | 5.Repeatability accuracy (X,Y&Z): ±0.015 mm      |
| 6.机器人侧重量: 6.2 kg             | 6.Robot side's weight: 6.2 kg                    |
| 7.夹具侧重量: 2.8 kg              | 7.Gripper side's weight: 2.8 kg                  |
| 8.最大允许角偏移: ±1°               | 8.Maximum allowable angle deviation: ±1°         |
| 9.直通型气孔尺寸(数量): (12) 3/8      | 9.Size of straight air hole (quantity): (12) 3/8 |

### 机器人侧

#### Robot side

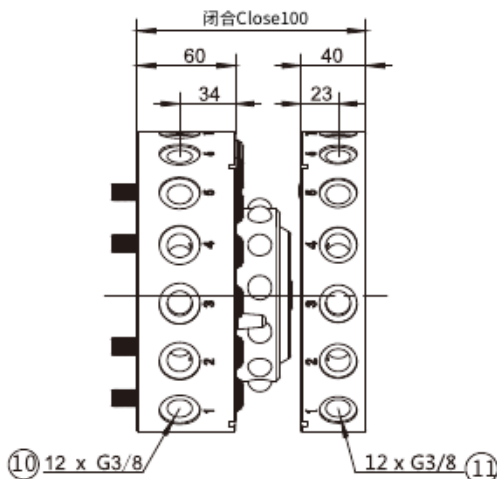
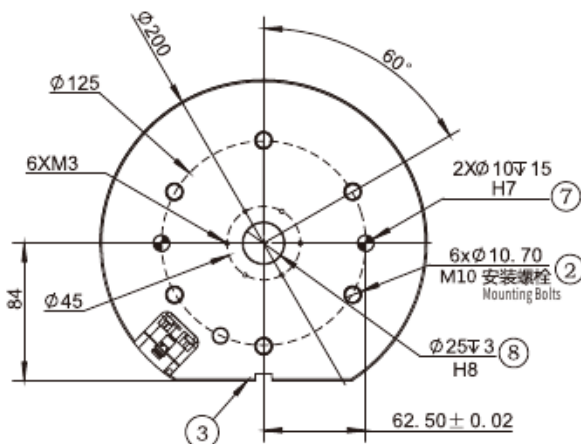
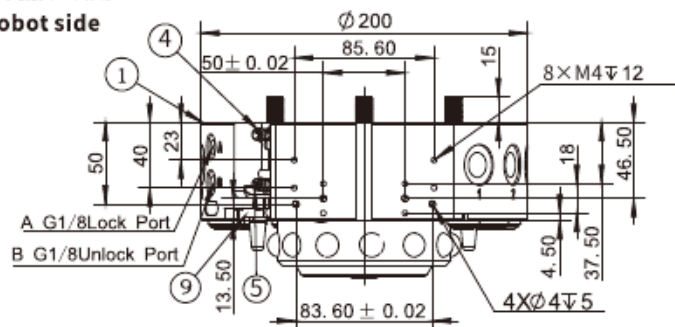

- A. 空气接口锁紧 The air connection locked
- B. 空气接口松开 Air connection released
- 1. 机器人侧连接 Robot side connection
- 2. 螺纹连接用通孔 Threaded through-holes
- 3. 选配件安装面 Optional mounting surface
- 4. 监控位置松开 Monitoring position released
- 5. 监控位置锁紧 Monitor position locked
- 7. 连接用定位销 Positioning pin
- 8. 中心定位用 Central positioning
- 9. 机器人侧确认接近开关 Proximity switch for robot side confirmation
- 10. 直通型气孔 Straight through air hole
- 11. 直通型气孔 Straight through air hole

# 自动快换 Quick Changer

## 夹具侧 Gripper side

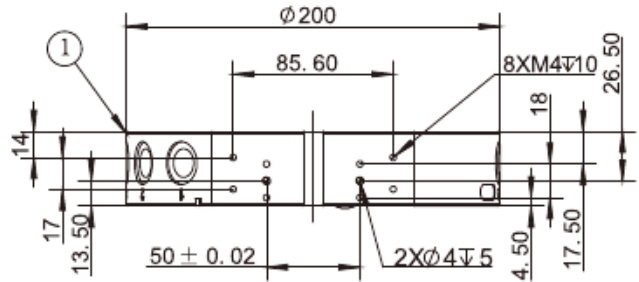
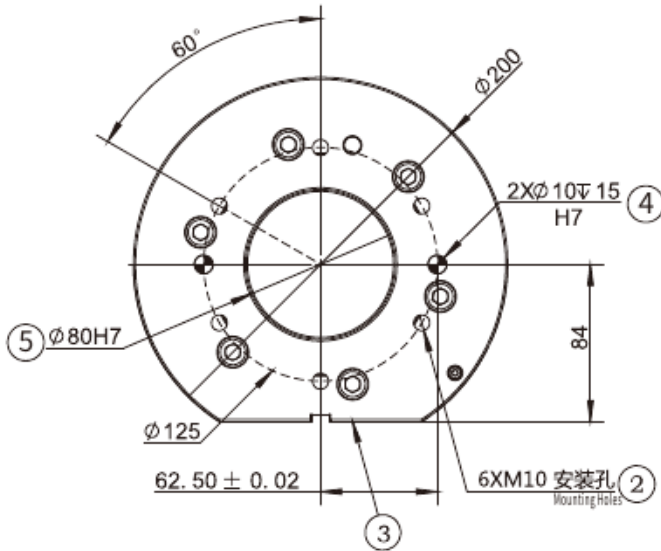

1. 夹具侧连接 Gripper side connection
2. 螺纹连接用通孔 Threaded through-holes
3. 选配件安装面 Optional mounting surface
4. 连接用定位销 Positioning pin
5. 中心定位用 Central positioning

# 适用模块 Applicable module

## 信号模块 Signal Type

产品名称 Product Name	型号 Model	货号 PN	工作电压 Working Voltage	工作电流 Working Current	接插件 Connector	接插件货号 Connector PN
机器人侧信号模块 Robot side signal module	QCSM-15R2	7.Y00468	24V	2.5A	D-Sub15R2-1000 ①	1.Y10080
夹具侧信号模块 Gripper side signal module	QCSM-15G2	7.Y00469	24V	2.5A	D-Sub15G2-1000 ①	1.Y10081
机器人侧信号模块 Robot side signal module	QCSM-19R	7.Y00954	220V	3A	MS3116F14-19S/-Y ②	1.Y11420
机器人侧信号模块 Robot side signal module	QCSM-19R1	7.Y02123	220V	3A	CMB08E-14-19S(072)SR-B ②	1.Y11863
机器人侧信号模块 Robot side signal module	QCSM-19R1	7.Y02123	220V	3A	MS3116F14-19S/-Y ②	1.Y11420
机器人侧信号模块 Robot side signal module	QCSM-19R1	7.Y02123	220V	3A	CMB08E-14-19S(072)SR-B ②	1.Y11863
夹具侧信号模块 Gripper side signal module	QCSM-19G	7.Y00955	220V	3A	MS3116F14-19P/-Y ②	1.Y11419
夹具侧信号模块 Gripper side signal module	QCSM-19G	7.Y00955	220V	3A	CMB08E-14-19P(072)SR-B ②	1.Y11864
机器人侧信号模块 Robot side signal module	QCSM-26R	7.Y00464	220V	3A	MS3116F16-26S/-Y ②	1.Y11867
机器人侧信号模块 Robot side signal module	QCSM-26R	7.Y00464	220V	3A	CMB08E-16-26S(072)SR-B ②	1.Y11865
夹具侧信号模块 Gripper side signal module	QCSM-26G	7.Y00465	220V	3A	MS3116F16-26P/-Y ②	1.Y11369
夹具侧信号模块 Gripper side signal module	QCSM-26G	7.Y00465	220V	3A	CMB08E-16-26P(072)SR-B ②	1.Y11866
夹具侧信号模块 Gripper side signal module	QCSM-21/26G	7.Y02117	220V	3A	MS3116F16-26P/-Y ②	1.Y11369
夹具侧信号模块 Gripper side signal module	QCSM-21/26G	7.Y02117	220V	3A	CMB08E-16-26P(072)SR-B ②	1.Y11866
机器人侧信号模块 Robot side signal module	QCSM-32R	7.Y02095	220V	3A	MS3116F22-36S ②	1.Y13392
机器人侧信号模块 Robot side signal module	QCSM-32R	7.Y02095	220V	3A	MS3118F22-36S ②	1.Y13393
夹具侧信号模块 Gripper side signal module	QCSM-32G	7.Y02096	220V	3A	MS3116F22-36P ②	1.Y13394
夹具侧信号模块 Gripper side signal module	QCSM-32G	7.Y02096	220V	3A	MS3118F22-36P ②	1.Y13395

① 连接线缆材长为1米 The cable's length is 1 meter

② 仅接头, 不含线材 Joint only, no wire

## 适用模块

### Applicable module

## 强电模块

### Power Module

产品名称 Product Name	型号 Model	货号 PN	工作电压 Working Voltage	工作电流 Working Current	接插件 Connector	接插件货号 Connector PN
机器人侧强电模块 Robot side power module	QCHFME14-C1R	7.Y02003	1.4KV	5A	-	-
夹具侧强电模块 Gripper side power module	QCHFME14-C1G	7.Y02004	1.4KV	5A	-	-
机器人侧强电模块 Robot side power module	QCSM-08R	7.Y00477	380V	20A	3108A22-08S <sup>②</sup>	1.Y10710
夹具侧强电模块 Gripper side power module	QCSM-08G	7.Y00478	380V	20A	3108A22-08P <sup>②</sup>	1.Y10711

② 仅接头, 不含线材 Joint only, no wire

## 通讯模块

### Communication Module

产品名称 Product Name	型号 Model	货号 PN
机器人侧通讯模块 Robot side communication module	QCSM-05G7/8-04M12-10R	7.Y02118
夹具侧通讯模块 Gripper side communication module	QCSM-05G7/8-04M12-10G	7.Y02119
机器人侧通讯模块 Robot side communication module	QCSM-RJ45-06R	7.Y02007
夹具侧通讯模块 Gripper side communication module	QCSM-RJ45-06G	7.Y02008
机器人侧通讯模块 Robot side communication module	QCSM-05G7/8-04G7/8-10R	7.Y02115
夹具侧通讯模块 Gripper side communication module	QCSM-05G7/8-04G7/8-10G	7.Y02075

## 气路模块

### Pneumatic Module

产品名称 Product Name	型号 Model	货号 PN	气路 Gas path	螺纹孔 Threaded Hole
机器人侧气路模块 Robot side pneumatic module	QCAM-01G2R	7.Y03893	-	-
夹具侧气路模块 Gripper side pneumatic module	QCAM-01G2G	7.Y03894	-	-
机器人侧气路模块 Robot side pneumatic module	QCAM-06G18R	7.Y01015	6	G1/8
夹具侧气路模块 Gripper side pneumatic module	QCAM-06G18G	7.Y01016	6	G1/8
机器人侧气路模块 Robot side pneumatic module	QCAM-06G18R-E	7.Y01018	6	G1/8
夹具侧气路模块 Gripper side pneumatic module	QCAM-06G18G-E	7.Y01019	6	G1/8
机器人侧气路模块 Robot side pneumatic module	QCAM-10M5R	7.Y01053	10	M5
夹具侧气路模块 Gripper side pneumatic module	QCAM-10M5G	7.Y01054	10	M5

## 水气模块

### Water-Pneumatic Module

产品名称 Product Name	型号 Model	货号 PN
机器人侧水气模块 Robot side water pneumatic module	QCWM-02R	7.Y02049
夹具侧水气模块 Gripper side water pneumatic module	QCWM-02G	7.Y02050

## 伺服模块

### Servo Module

产品名称 Product Name	型号 Model	货号 PN
机器人侧伺服模块 Robot side servo module	QCSM-12R	7.Y02082
夹具侧伺服模块 Gripper side servo module	QCSM-12G	7.Y02083
机器人侧伺服模块 Robot side servo module	QCSM-08R1	7.Y02080
夹具侧伺服模块 Gripper side servo module	QCSM-08G1	7.Y02081
机器人侧伺服模块 Robot side servo module	QCSM-06/11R	7.Y02673
夹具侧伺服模块 Gripper side servo module	QCSM-06/11G	7.Y02674
机器人侧伺服模块 Robot side servo module	QCSM-06/11R1	7.Y02675
夹具侧伺服模块 Gripper side servo module	QCSM-06/11G1	7.Y02676

Profile- SUS Tube  
型材、钢管

Stents Module  
支架模组

Quick Changer  
快换

Grip Module  
夹具组件

Air Nipper  
气动剪刀

Vacuum Module  
真空组件

Accessory Components  
附件

# 自动快换

Quick Changer

## QCA-200RS-SN(SP)-D1 NEW



机器人侧带开关  
Robot side strap switch

货号(PN)	8.Y01310	8.Y01315
型号(Model)	QCA-200RS-SP-D1	QCA-200RS-SN-D1
信号检测类别 Signal Detection Category	PNP	NPN

### 产品参数

#### Parameter

- 1.最大负载:300 kg
- 2.锁紧力@80Psi(5.5Bar):16000 N
- 3.静态承载力矩(X&Y):1360 Nm
- 4.静态承载力矩(Z):1130 Nm
- 5.位置重复精度(X,Y&Z):±0.015 mm
- 6.机器人侧带开关重量:6.75 kg
- 7.最大允许角偏移:±1°
- 8.直通型气孔尺寸(数量):(8)3/8
- 9.增加弹簧结构 断气后双重安全防掉落

- 1.Max payload: 300kg
- 2.Locking force@80Psi (5.5Bar): 16000 N
- 3.Static Load torque (X&Y): 1360 Nm
- 4.Static Load torque (Z): 1130 Nm
- 5.Repeatability accuracy (X,Y&Z): ±0.015mm
- 6.Robot side's strap switch weight: 6.2 kg
- 7.Maximum allowable angle deviation: ±1°
- 8.Size of straight air hole (quantity): (8)3/8
- 9.Enhanced spring mechanism Dual safety protection against falling after air supply interruption

### 机器人侧

#### Robot side

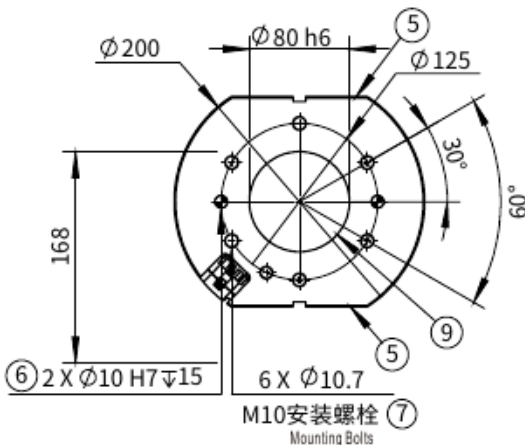
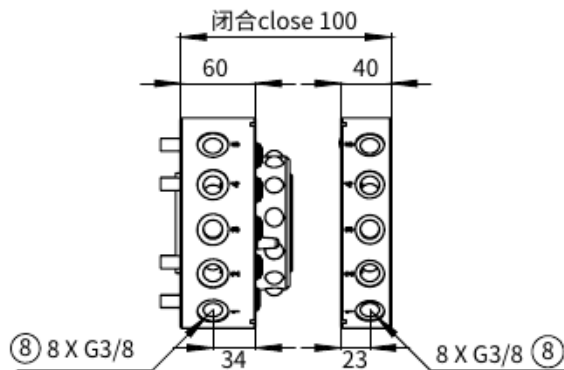
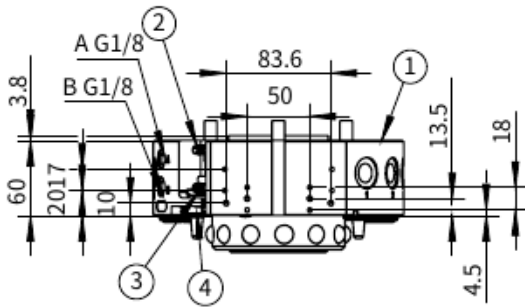

- A. 空气接口锁紧 The air connection locked
  - B. 空气接口松开 Air connection released
  1. 机械人侧连接面 Robot side connection
  2. 监控位置松开 Monitor position released
  3. 监控位置锁紧 Monitoring position locked
  4. 机器人侧确认接近开关 Robot side proximity switch confirmation
  5. 选配件安装面 Optional mounting surface
  6. 连接用定位销孔 Locating pin hole for connection
  7. 螺纹连接用通孔 Through hole for threaded connection
  8. 直通型气孔 Straight through air hole
  9. 安装用定位环 Installation positioning ring
- 机器人侧安装孔 Robot side mounting holes  
ISO-9409-1-125-6-M10

# 自动快换

Quick Changer

## QCA-200-D1



机器人侧  
Robot side



夹具侧  
Gripper side

货号(PN)	8.Y00272-SP-D1	8.Y00272-SN-D1
型号(Model)	QCA-200R-SP-D1	QCA-200R-SN-D1
信号检测类别 Signal Detection Category	PNP	NPN

货号(PN)	8.Y00357-D1
型号(Model)	QCA-200G-D1

### 产品参数

#### Parameter

- 1.最大负载:300 kg
- 2.锁紧力@80Psi(5.5Bar):16000 N
- 3.静态承载力矩(X&Y):1360 Nm
- 4.静态承载力矩(Z):1130 Nm
- 5.位置重复精度(X,Y&Z):±0.015 mm
- 6.机器人侧重量:6.2 kg
- 7.夹具侧重量:2.8 kg
- 8.最大允许角偏移:±1°
- 8.直通型气孔尺寸(数量):(8) 3/8

- 1.Max payload: 300kg
- 2.Locking force@80Psi (5.5Bar): 16000 N
- 3.Static Load torque (X&Y): 1360 Nm
- 4.Static Load torque (Z): 1130 Nm
- 5.Repeatability accuracy (X,Y&Z): ±0.015 mm
- 6.Robot side's weight: 6.2 kg
- 7.Gripper side's weight: 2.8 kg
- 8.Maximum allowable angle deviation: ±1°
- 9.Size of straight air hole (quantity): (8) 3/8

### 机器人侧

#### Robot side

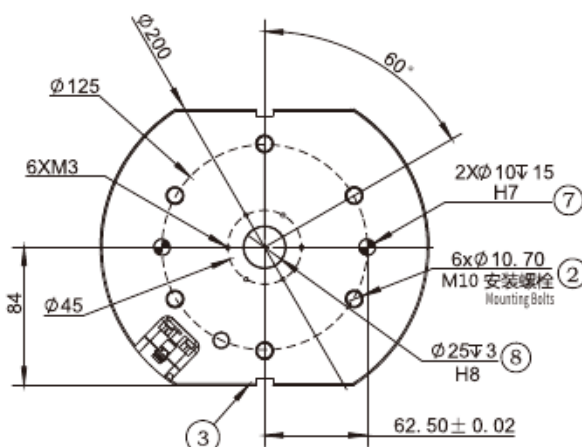
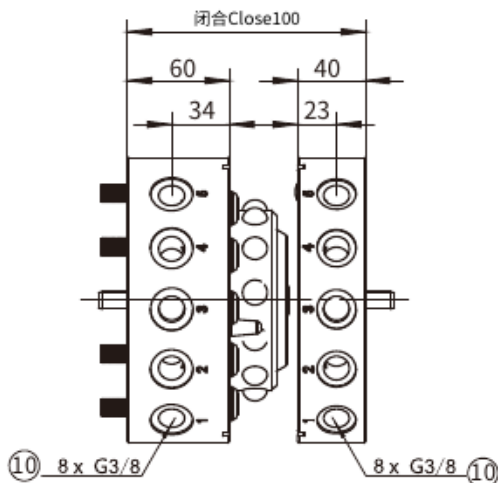
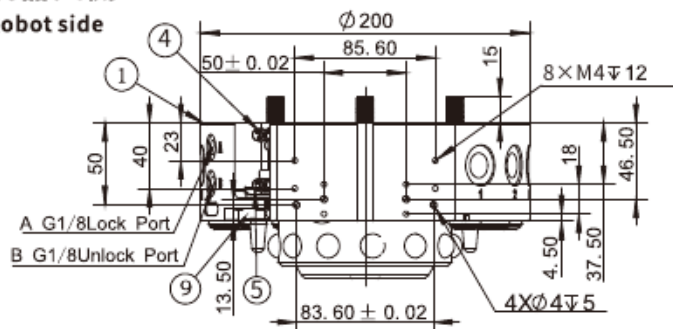

- A. 空气接口锁紧 The air connection locked
- B. 空气接口松开 Air connection released
- 1. 机器人侧连接 Robot side connection
- 2. 螺纹连接用通孔 Threaded through-holes
- 3. 选配件安装面 Optional mounting surface
- 4. 监控位置锁紧 Monitoring position locked
- 5. 监控位置松开 Monitor position released
- 7. 连接用定位销 Positioning pin
- 8. 中心定位用 Central positioning
- 9. 机器人侧确认接近开关 Proximity switch for robot side confirmation
- 10. 直通型气孔 Straight through air hole
- 11. 直通型气孔 Straight through air hole

# 自动快换 Quick Changer

## 夹具侧 Gripper side

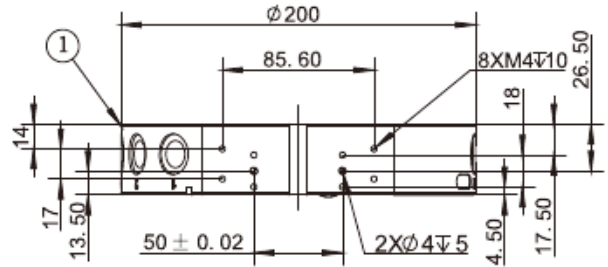
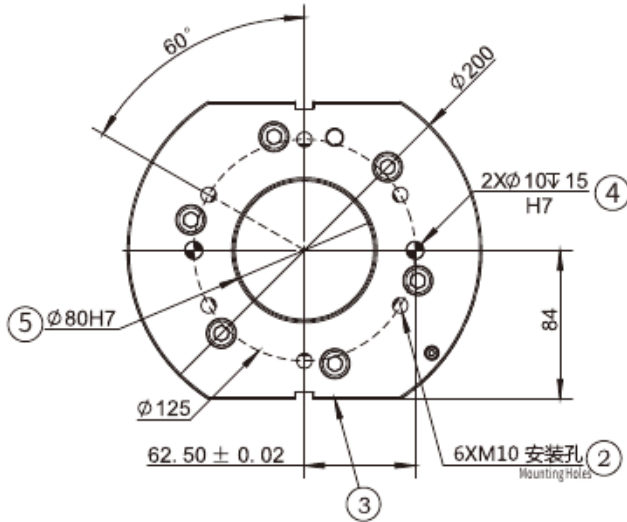

1. 夹具侧连接 Gripper side connection
2. 螺纹连接用通孔 Threaded through-holes
3. 选配件安装面 Optional mounting surface
4. 连接用定位销 Positioning pin
5. 中心定位用 Central positioning

# 适用模块 Applicable module

## 信号模块 Signal Type

产品名称 Product Name	型号 Model	货号 PN	工作电压 Working Voltage	工作电流 Working Current	接插件 Connector	接插件货号 Connector PN
机器人侧信号模块 Robot side signal module	QCSM-15R2	7.Y00468	24V	2.5A	D-Sub15R2-1000 ①	1.Y10080
夹具侧信号模块 Gripper side signal module	QCSM-15G2	7.Y00469	24V	2.5A	D-Sub15G2-1000 ①	1.Y10081
机器人侧信号模块 Robot side signal module	QCSM-19R	7.Y00954	220V	3A	MS3116F14-19S/-Y ②	1.Y11420
机器人侧信号模块 Robot side signal module	QCSM-19R1	7.Y02123	220V	3A	CMB08E-14-19S(072)SR-B ②	1.Y11863
机器人侧信号模块 Robot side signal module	QCSM-19R1	7.Y02123	220V	3A	MS3116F14-19S/-Y ②	1.Y11420
机器人侧信号模块 Robot side signal module	QCSM-19R1	7.Y02123	220V	3A	CMB08E-14-19S(072)SR-B ②	1.Y11863
夹具侧信号模块 Gripper side signal module	QCSM-19G	7.Y00955	220V	3A	MS3116F14-19P/-Y ②	1.Y11419
夹具侧信号模块 Gripper side signal module	QCSM-19G	7.Y00955	220V	3A	CMB08E-14-19P(072)SR-B ②	1.Y11864
机器人侧信号模块 Robot side signal module	QCSM-26R	7.Y00464	220V	3A	MS3116F16-26S/-Y ②	1.Y11867
机器人侧信号模块 Robot side signal module	QCSM-26R	7.Y00464	220V	3A	CMB08E-16-26S(072)SR-B ②	1.Y11865
夹具侧信号模块 Gripper side signal module	QCSM-26G	7.Y00465	220V	3A	MS3116F16-26P/-Y ②	1.Y11369
夹具侧信号模块 Gripper side signal module	QCSM-26G	7.Y00465	220V	3A	CMB08E-16-26P(072)SR-B ②	1.Y11866
夹具侧信号模块 Gripper side signal module	QCSM-21/26G	7.Y02117	220V	3A	MS3116F16-26P/-Y ②	1.Y11369
夹具侧信号模块 Gripper side signal module	QCSM-21/26G	7.Y02117	220V	3A	CMB08E-16-26P(072)SR-B ②	1.Y11866
机器人侧信号模块 Robot side signal module	QCSM-32R	7.Y02095	220V	3A	MS3116F22-36S ②	1.Y13392
机器人侧信号模块 Robot side signal module	QCSM-32R	7.Y02095	220V	3A	MS3118F22-36S ②	1.Y13393
夹具侧信号模块 Gripper side signal module	QCSM-32G	7.Y02096	220V	3A	MS3116F22-36P ②	1.Y13394
夹具侧信号模块 Gripper side signal module	QCSM-32G	7.Y02096	220V	3A	MS3118F22-36P ②	1.Y13395

① 连接线缆材长为1米 The cable's length is 1 meter

② 仅接头, 不含线材 Joint only, no wire

## 适用模块

### Applicable module

## 强电模块

### Power Module

产品名称 Product Name	型号 Model	货号 PN	工作电压 Working Voltage	工作电流 Working Current	接插件 Connector	接插件货号 Connector PN
机器人侧强电模块 Robot side power module	QCHFME14-C1R	7.Y02003	1.4KV	5A	-	-
夹具侧强电模块 Gripper side power module	QCHFME14-C1G	7.Y02004	1.4KV	5A	-	-
机器人侧强电模块 Robot side power module	QCSM-08R	7.Y00477	380V	20A	3108A22-08S <sup>②</sup>	1.Y10710
夹具侧强电模块 Gripper side power module	QCSM-08G	7.Y00478	380V	20A	3108A22-08P <sup>②</sup>	1.Y10711

② 仅接头, 不含线材 Joint only, no wire

## 通讯模块

### Communication Module

产品名称 Product Name	型号 Model	货号 PN
机器人侧通讯模块 Robot side communication module	QCSM-05G7/8-04M12-10R	7.Y02118
夹具侧通讯模块 Gripper side communication module	QCSM-05G7/8-04M12-10G	7.Y02119
机器人侧通讯模块 Robot side communication module	QCSM-RJ45-06R	7.Y02007
夹具侧通讯模块 Gripper side communication module	QCSM-RJ45-06G	7.Y02008
机器人侧通讯模块 Robot side communication module	QCSM-05G7/8-04G7/8-10R	7.Y02115
夹具侧通讯模块 Gripper side communication module	QCSM-05G7/8-04G7/8-10G	7.Y02075

## 气路模块

### Pneumatic Module

产品名称 Product Name	型号 Model	货号 PN	气路 Gas path	螺纹孔 Threaded Hole
机器人侧气路模块 Robot side pneumatic module	QCAM-01G2R	7.Y03893	-	-
夹具侧气路模块 Gripper side pneumatic module	QCAM-01G2G	7.Y03894	-	-
机器人侧气路模块 Robot side pneumatic module	QCAM-06G18R	7.Y01015	6	G1/8
夹具侧气路模块 Gripper side pneumatic module	QCAM-06G18G	7.Y01016	6	G1/8
机器人侧气路模块 Robot side pneumatic module	QCAM-06G18R-E	7.Y01018	6	G1/8
夹具侧气路模块 Gripper side pneumatic module	QCAM-06G18G-E	7.Y01019	6	G1/8
机器人侧气路模块 Robot side pneumatic module	QCAM-10M5R	7.Y01053	10	M5
夹具侧气路模块 Gripper side pneumatic module	QCAM-10M5G	7.Y01054	10	M5

## 水气模块

### Water-Pneumatic Module

产品名称 Product Name	型号 Model	货号 PN
机器人侧水气模块 Robot side water pneumatic module	QCWM-02R	7.Y02049
夹具侧水气模块 Gripper side water pneumatic module	QCWM-02G	7.Y02050

## 伺服模块

### Servo Module

产品名称 Product Name	型号 Model	货号 PN
机器人侧伺服模块 Robot side servo module	QCSM-12R	7.Y02082
夹具侧伺服模块 Gripper side servo module	QCSM-12G	7.Y02083
机器人侧伺服模块 Robot side servo module	QCSM-08R1	7.Y02080
夹具侧伺服模块 Gripper side servo module	QCSM-08G1	7.Y02081
机器人侧伺服模块 Robot side servo module	QCSM-06/11R	7.Y02673
夹具侧伺服模块 Gripper side servo module	QCSM-06/11G	7.Y02674
机器人侧伺服模块 Robot side servo module	QCSM-06/11R1	7.Y02675
夹具侧伺服模块 Gripper side servo module	QCSM-06/11G1	7.Y02676

Profile- SUS Tube  
型材、钢管

Stents Module  
支架模组

Quick Changer  
快换

Grip Module  
夹具组件

Air Nipper  
气动剪刀

Vacuum Module  
真空组件

Accessory Components  
附件

# 自动快换

## Quick Changer

### QCA-S300



机器人侧  
Robot side

货号(PN)	8.Y01102
型号(Model)	QCA-S300R-SP
信号检测类别 Signal Detection Category	PNP



夹具侧  
Gripper side

货号(PN)	8.Y01052
型号(Model)	QCA-S300G

### 产品参数

#### Parameter

- 1.最大负载:300 kg
- 2.锁紧力@80Psi(5.5Bar):31000 N
- 3.静态承载力矩(X&Y): 2710 Nm
- 4.静态承载力矩(Z):2260 Nm
- 5.位置重复精度(X,Y&Z):±0.015 mm
- 6.机器人侧重量:6.44 kg
- 7.夹具侧重量:2.86 kg
- 8.最大允许角偏移:±1°
- 9.直通型气孔尺寸(数量):(5)NPT3/8  
(4)NPT1/2

- 1.Max payload: 300kg
- 2.Locking force@80Psi(5.5Bar): 31000 N
- 3.Static Load torque (X&Y): 2710 Nm
- 4.Static Load torque (Z): 2260 Nm
- 5.Repeatability accuracy (X,Y&Z): ±0.015 mm
- 6.Robot side's weight: 6.44 kg
- 7.Gripper side's weight: 2.86 kg
- 8.Maximum allowable angle deviation: ±1°
- 9.Size of straight air hole(quantity): (5)NPT3/8  
(4)NPT1/2

### 机器人侧

#### Robot side

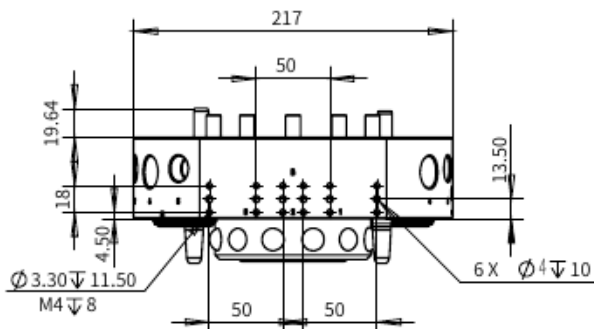
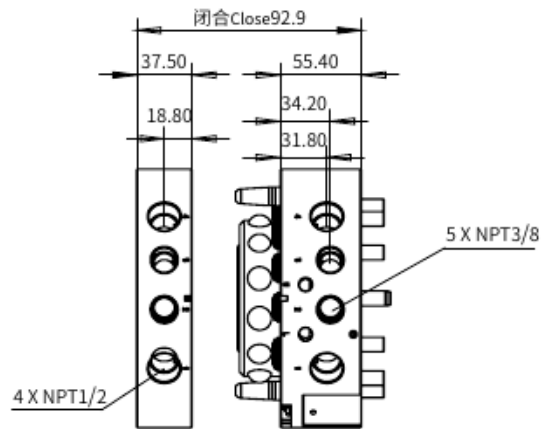
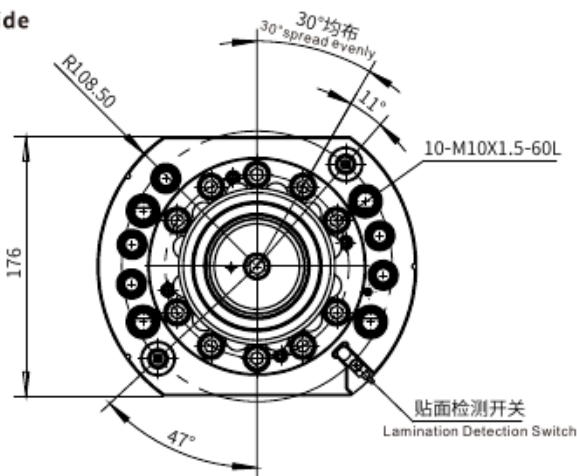

# 自动快换 Quick Changer

## 夹具侧 Gripper side

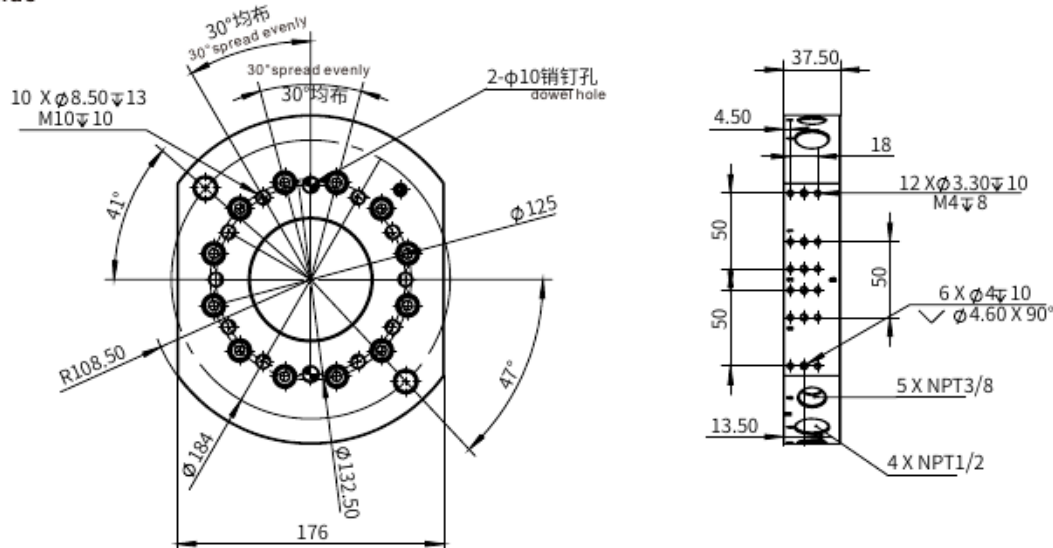

## 适用模块 Applicable module

### 信号模块 Signal Type

产品名称 Product Name	型号 Model	货号 PN	工作电压 Working Voltage	工作电流 Working Current	接插件 Connector	接插件货号 Connector PN
机器人侧信号模块 Robot side signal module	QCSM-15R2	7.Y00468	24V	2.5A	D-Sub15R2-1000 ①	1.Y10080
夹具侧信号模块 Gripper side signal module	QCSM-15G2	7.Y00469	24V	2.5A	D-Sub15G2-1000 ①	1.Y10081
机器人侧信号模块 Robot side signal module	QCSM-19R	7.Y00954	220V	3A	MS3116F14-19S/-Y ② CMB08E-14-19S(072)SR-B ②	1.Y11420 1.Y11863
机器人侧信号模块 Robot side signal module	QCSM-19R1	7.Y02123	220V	3A	MS3116F14-19S/-Y ② CMB08E-14-19S(072)SR-B ②	1.Y11420 1.Y11863
夹具侧信号模块 Gripper side signal module	QCSM-19G	7.Y00955	220V	3A	MS3116F14-19P/-Y ② CMB08E-14-19P(072)SR-B ②	1.Y11419 1.Y11864
机器人侧信号模块 Robot side signal module	QCSM-26R	7.Y00464	220V	3A	MS3116F16-26S/-Y ② CMB08E-16-26S(072)SR-B ②	1.Y11867 1.Y11865
夹具侧信号模块 Gripper side signal module	QCSM-26G	7.Y00465	220V	3A	MS3116F16-26P/-Y ② CMB08E-16-26P(072)SR-B ②	1.Y11369 1.Y11866
夹具侧信号模块 Gripper side signal module	QCSM-21/26G	7.Y02117	220V	3A	MS3116F16-26P/-Y ② CMB08E-16-26P(072)SR-B ②	1.Y11369 1.Y11866
机器人侧信号模块 Robot side signal module	QCSM-32R	7.Y02095	220V	3A	MS3116F22-36S ② MS3118F22-36S ②	1.Y13392 1.Y13393
夹具侧信号模块 Gripper side signal module	QCSM-32G	7.Y02096	220V	3A	MS3116F22-36P ② MS3118F22-36P ②	1.Y13394 1.Y13395

① 连接线材长为1米 The cable's length is 1 meter

② 仅接头, 不含线材 Joint only, no wire

Profile- SUS Tube

Stents Module

Quick Changer

Gripper Module

Air Nipper

Vacuum Module

Accessory Components

## 适用模块

### Applicable module

### 强电模块

#### Power Module

产品名称 Product Name	型号 Model	货号 PN	工作电压 Working Voltage	工作电流 Working Current	接插件 Connector	接插件货号 Connector PN
机器人侧强电模块 Robot side power module	QCHFME14-C1R	7.Y02003	1.4KV	5A	-	-
夹具侧强电模块 Gripper side power module	QCHFME14-C1G	7.Y02004	1.4KV	5A	-	-
机器人侧强电模块 Robot side power module	QCSM-08R	7.Y00477	380V	20A	3108A22-08S <sup>②</sup>	1.Y10710
夹具侧强电模块 Gripper side power module	QCSM-08G	7.Y00478	380V	20A	3108A22-08P <sup>②</sup>	1.Y10711

② 仅接头, 不含线材 Joint only, no wire

### 通讯模块

#### Communication Module

产品名称 Product Name	型号 Model	货号 PN
机器人侧通讯模块 Robot side communication module	QCSM-05G7/8-04M12-10R	7.Y02118
夹具侧通讯模块 Gripper side communication module	QCSM-05G7/8-04M12-10G	7.Y02119
机器人侧通讯模块 Robot side communication module	QCSM-RJ45-06R	7.Y02007
夹具侧通讯模块 Gripper side communication module	QCSM-RJ45-06G	7.Y02008
机器人侧通讯模块 Robot side communication module	QCSM-05G7/8-04G7/8-10R	7.Y02115
夹具侧通讯模块 Gripper side communication module	QCSM-05G7/8-04G7/8-10G	7.Y02075

### 伺服模块

#### Servo Module

产品名称 Product Name	型号 Model	货号 PN
机器人侧伺服模块 Robot side servo module	QCSM-12R	7.Y02082
夹具侧伺服模块 Gripper side servo module	QCSM-12G	7.Y02083
机器人侧伺服模块 Robot side servo module	QCSM-08R1	7.Y02080
夹具侧伺服模块 Gripper side servo module	QCSM-08G1	7.Y02081
机器人侧伺服模块 Robot side servo module	QCSM-06/11R	7.Y02673
夹具侧伺服模块 Gripper side servo module	QCSM-06/11G	7.Y02674
机器人侧伺服模块 Robot side servo module	QCSM-06/11R1	7.Y02675
夹具侧伺服模块 Gripper side servo module	QCSM-06/11G1	7.Y02676

### 气路模块

#### Pneumatic Module

产品名称 Product Name	型号 Model	货号 PN	气路 Gas path	螺纹孔 Threaded Hole
机器人侧气路模块 Robot side pneumatic module	QCAM-06G18R	7.Y01015	6	G1/8
夹具侧气路模块 Gripper side pneumatic module	QCAM-06G18G	7.Y01016	6	G1/8
机器人侧气路模块 Robot side pneumatic module	QCAM-06G18R-E	7.Y01018	6	G1/8
夹具侧气路模块 Gripper side pneumatic module	QCAM-06G18G-E	7.Y01019	6	G1/8
机器人侧气路模块 Robot side pneumatic module	QCAM-10M5R	7.Y01053	10	M5
夹具侧气路模块 Gripper side pneumatic module	QCAM-10M5G	7.Y01054	10	M5

产品名称 Product Name	型号 Model	货号 PN	气路 Gas path	螺纹孔 Threaded Hole
机器人侧气路模块 Robot side pneumatic module	QCAM-14M5R	7.Y01055	14	M5
夹具侧气路模块 Gripper side pneumatic module	QCAM-14M5G	7.Y01056	14	M5
机器人侧气路模块-自密封 Robot side pneumatic module self-sealing	QCAM-06G18R-F	7.Y02005	6	G1/8
夹具侧气路模块-自密封 Gripper side pneumatic module self-sealing	QCAM-06G18G-F	7.Y02006	6	G1/8
机器人侧气路模块 Robot side pneumatic module	QCAM-04G38R	7.Y02043	4	G3/8
夹具侧气路模块 Gripper side pneumatic module	QCAM-04G38G	7.Y02044	4	G3/8

### 水气模块

#### Water-Pneumatic Module

产品名称 Product Name	型号 Model	货号 PN
机器人侧水气模块 Robot side water-pneumatic module	QCWM-02R	7.Y02049
夹具侧水气模块 Gripper side water-pneumatic module	QCWM-02G	7.Y02050

Profile, SUS Tube  
型材、钢管

Stents Module  
支架模组

Quick Changer  
快换

Grip Module  
夹具组件

Air Blipper  
气动剪刀

Vacuum Module  
真空组件

Accessory Components  
附件

## 模块类型

### Module Type



镀金针脚  
Gold-plated stitching

### 电模块:用于总线信号及伺服电源的传输

- 突起的针状在连接保证接触的稳定性;抗干扰
- 额定电压电流:24V 2.5A~380V 200A(最高标准参数)
- 材质:镀金的针脚
- 弹压接触次数:大于30万次

### Electrical module: used for bus signal and servo power transmission

- The needle-like protrusions in the connection to ensure contact stability anti-interference.
- Rated voltage and current:24V 2.5A~380V 200A(the highest standard parameters)
- Material: gold-plated pin
- Elastic pressure contact number: more than 300,000 times

## 安装方法

### Installation method

#### 夹具侧模块安装方式

Module Mounting mode on gripper side



#### 机器人侧模块安装方式

Module Mounting mode on robot side



## 模块类型

### Module Type



镀金针脚  
Gold-plated stitching

#### 电模块:用于总线信号及伺服电源的传输

- 突起的针状在连接保证接触的稳定性;抗干扰
- 额定电压电流:24V 2.5A~380V 200A(最高标准参数)
- 材质:镀金的针脚
- 弹压接触次数:大于30万次

#### Electrical module: used for bus signal and servo power transmission

- The needle-like protrusions in the connection to ensure contact stability anti-interference.
- Rated voltage and current:24V 2.5A~380V 200A(the highest standard parameters)
- Material: gold-plated pin
- Elastic pressure contact number: more than 300,000 times

## 安装方法

### Installation method

#### 夹具侧模块安装方式

Module Mounting mode on gripper side

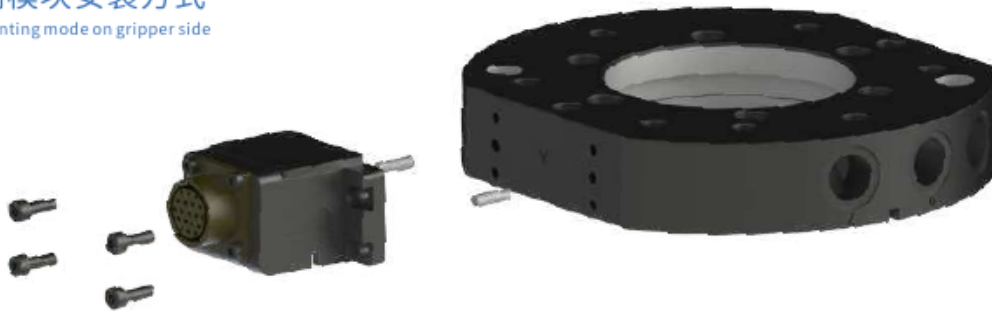

#### 机器人侧模块安装方式

Module Mounting mode on robot side



# 信号模块

Signal Module

## QCSM-15R1

机器人侧模块  
Robot side module



货号(PN)	7.Y00965
型号(Model)	QCSM-15R1

- ※ 电压Voltage:24V
- ※ 电流Current:2.5A
- ※ 重量Weight:30.5g
- ※ 适配于 Suitable for: QCA-05, QCA-15, QCA-25

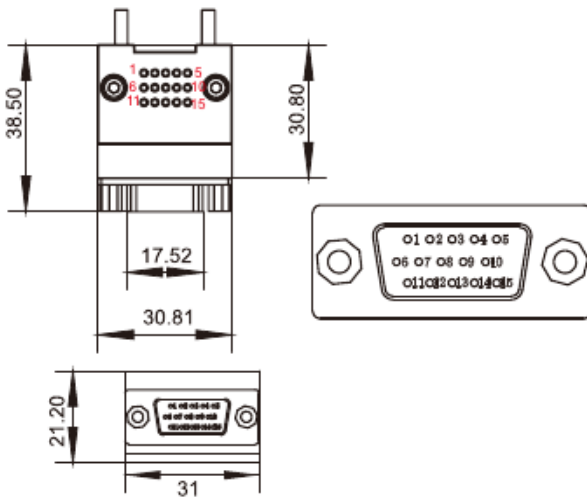

## QCSM-15G1

夹具侧模块  
Gripper side module



货号(PN)	7.Y00966
型号(Model)	QCSM-15G1

- ※ 电压Voltage:24V
- ※ 电流Current:2.5A
- ※ 重量Weight:29.8g

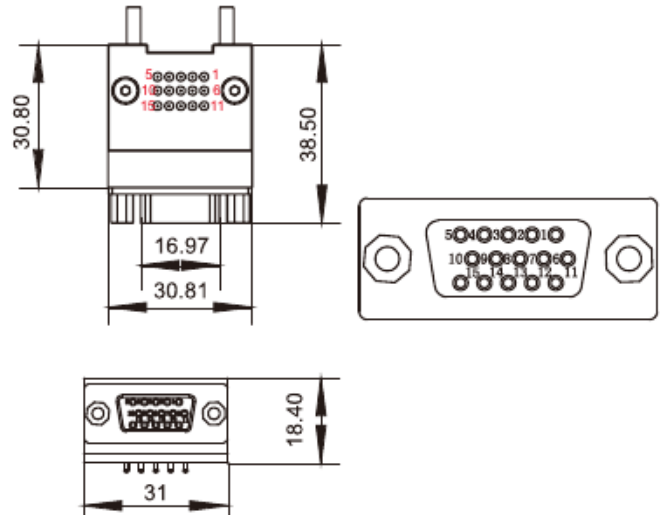

Profile- SUS Tube  
型材、钢管

Stents Module  
支架模组

Quick Changer  
快换

Grip Module  
夹具组件

Air Nipper  
气动剪刀

Vacuum Module  
真空组件

Accessory Components  
附件

# 信号模块-直出线

Signal Module-Straight Out Line

## QCSM-15R1-1000

机器人侧模块  
Robot side module



货号(PN)	7.Y02097
型号(Model)	QCSM-15R1-1000

- ※ 电压Voltage: 24V
- ※ 电流Current: 2.5A
- ※ 重量Weight: 152g
- ※ 连接线缆材长为1米(可定制) The wire's length is 1 meters(Customizable)
- ※ 适配于 Suitable for: QCA-05, QCA-15, QCA-25

## QCSM-15G1-1000

夹具侧模块  
Gripper side module



货号(PN)	7.Y02098
型号(Model)	QCSM-15G1-1000

- ※ 电压Voltage: 24V
- ※ 电流Current: 2.5A
- ※ 重量Weight: 158g

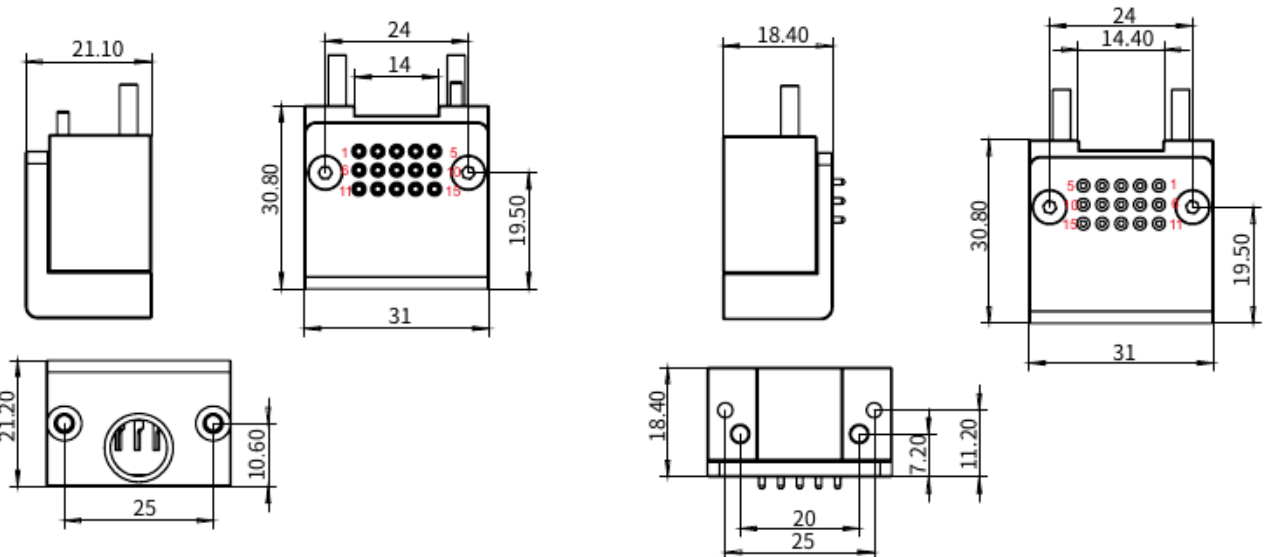

## 接线图/Wiring Diagram

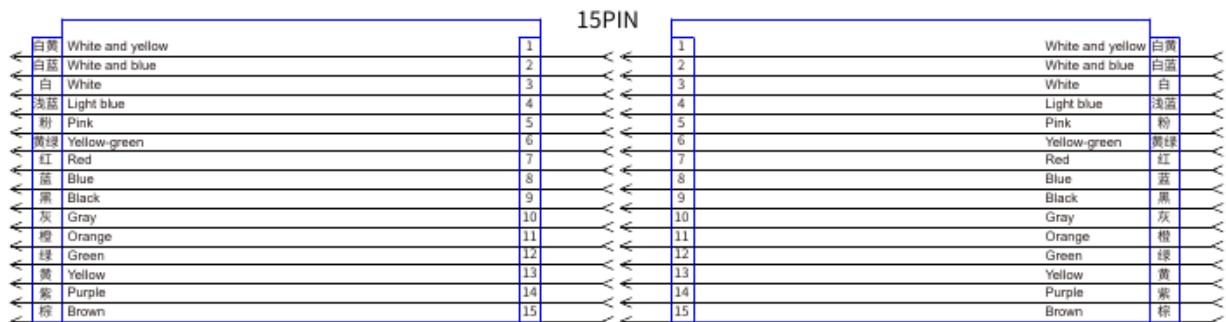

Profile, SUS Tube  
型材、钢管

Stents Module  
支架模组

Quick Changer  
快换

Grip Module  
夹具组件

Air Nipper  
气动剪刀

Vacuum Module  
真空组件

Accessory Components  
附件

# 贴面信号模块

## Surface-Mount Signal Module

NEW

### QCSM-TSR1

机器人侧模块  
Robot side module



货号(PN)	7.Y03880	7.Y03901
型号(Model)	QCSM-TSR1-SP	QCSM-TSR1-SN
信号检测类别 Signal Detection Category	PNP	NPN

※ 重量Weight: 33g

※ 为快换提供工具在位检测

Provide tools for in-place inspection during quick changeover

※ 适配于 Suitable for: QCA-05, QCA-15, QCA-25

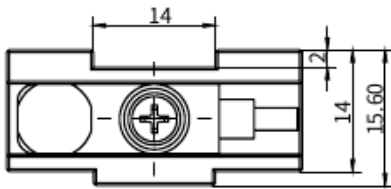
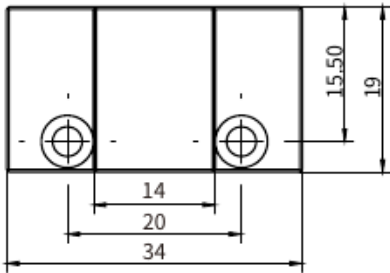

### QCSM-TSG1

夹具侧模块  
Gripper side module



货号(PN)	7.Y03881
型号(Model)	QCSM-TSG1

※ 重量Weight: 20g

※ 为快换提供工具在位检测

Provide tools for in-place inspection during quick changeover

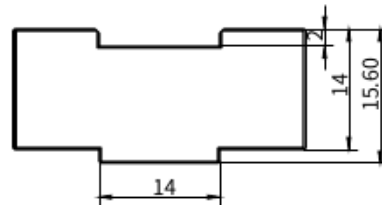
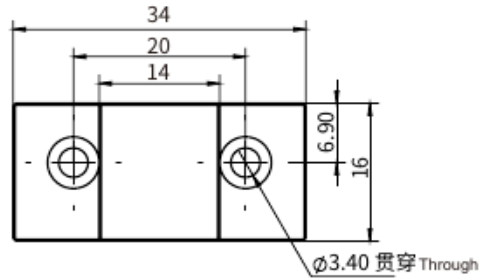

Profile- SUS Tube  
型材、钢管

Stents Module  
支架模组

Quick Changer  
快换

Grip Module  
夹具组件

Air Nipper  
气动剪刀

Vacuum Module  
真空组件

Accessory Components  
附件

# 贴面信号模块

## Surface-Mount Signal Module

NEW

Profile、SUS Tube  
型材、钢管

Stents Module  
支架模组

Quick Changer  
快换

Grip Module  
夹具组件

Air Nipper  
气动剪刀

Vacuum Module  
真空组件

Accessory Components  
附件

### QCSM-TSR2

机器人侧模块  
Robot side module



货号 (PN)	7.Y03882	7.Y03902
型号 (Model)	QCSM-TSR2-SP	QCSM-TSR2-SN
信号检测类别 Signal Detection Category	PNP	NPN

※ 重量 Weight: 57g  
 ※ 为快换提供工具在位检测  
 Provide tools for in-place inspection during quick changeover  
 ※ 适配于 Suitable for: QCA-35、QCA-50、QCA-550

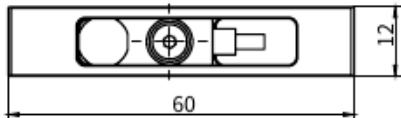
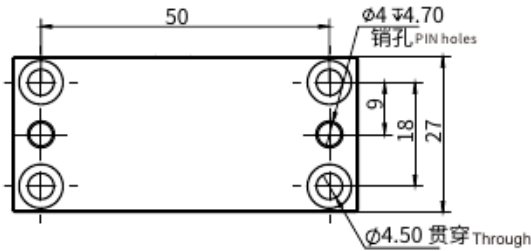

### QCSM-TSG2

夹具侧模块  
Gripper side module



货号 (PN)	7.Y03883
型号 (Model)	QCSM-TSG2

※ 重量 Weight: 48g  
 ※ 为快换提供工具在位检测  
 Provide tools for in-place inspection during quick changeover

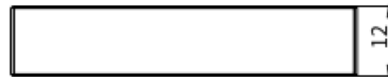
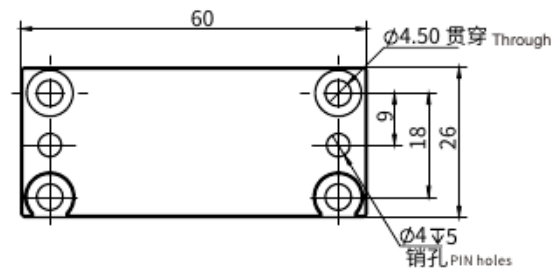

# 信号模块

## Signal Module

### QCSM-15R2

机器人侧模块  
Robot side module



货号(PN)	7.Y00468
型号(Model)	QCSM-15R2

- ※ 电压Voltage:24V
- ※ 电流Current:2.5A
- ※ 重量Weight:68g
- ※ 适配于 Suitable for: QCA-35, QCA-50, QCA-S50, QCA-100, QCA-S100, QCA-S150, QCA-200, QCA-200-D1, QCA-300

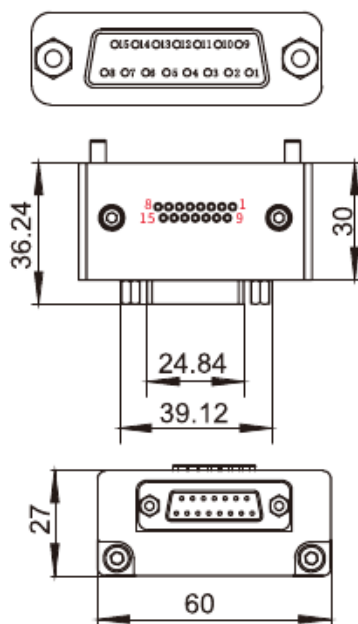

### QCSM-15G2

夹具侧模块  
Gripper side module



货号(PN)	7.Y00469
型号(Model)	QCSM-15G2

- ※ 电压Voltage:24V
- ※ 电流Current:2.5A
- ※ 重量Weight:48.5g

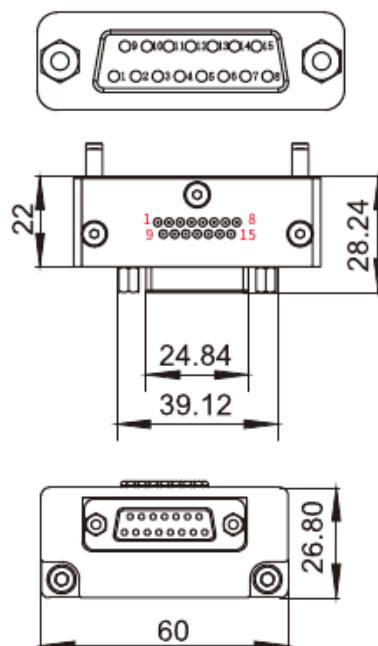

Profile- SUS Tube  
型材、钢管

Stents Module  
支架模组

Quick Changer  
快换

Grip Module  
夹具组件

Air Nipper  
气动剪刀

Vacuum Module  
真空组件

Accessory Components  
附件

# 信号模块

## Signal Module

### QCSM-19R

机器人侧模块  
Robot side module



货号(PN)	7.Y00954
型号(Model)	QCSM-19R

- \* 电压Voltage: 220V
- \* 电流Current: 3A
- \* 重量Weight: 178.3g
- \* 适配于 Suitable for: QCA-35, QCA-50, QCA-S50, QCA-100, QCA-S100, QCA-S150, QCA-200, QCA-200-D1, QCA-300

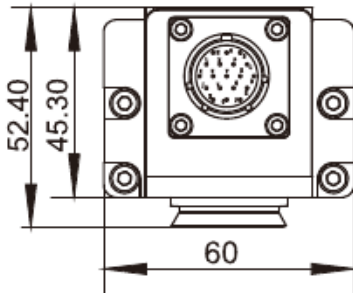
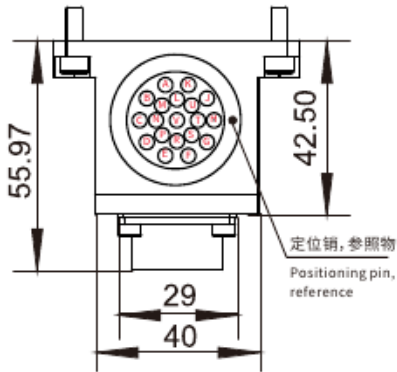

### QCSM-19G

夹具侧模块  
Gripper side module



货号(PN)	7.Y00955
型号(Model)	QCSM-19G

- \* 电压Voltage: 220V
- \* 电流Current: 3A
- \* 重量Weight: 130.7g

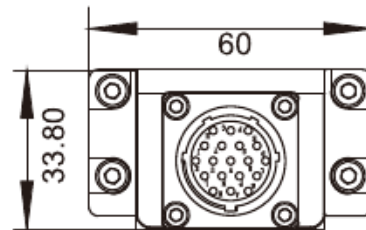
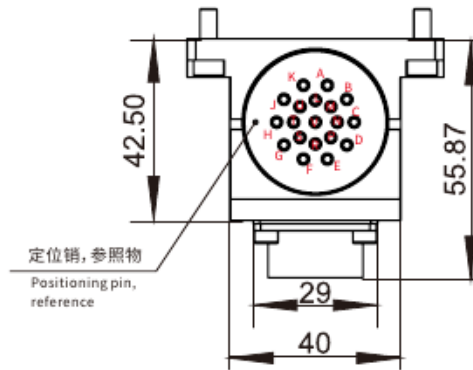

Profile、SUS Tube  
型材、钢管

Stents Module  
支架模组

Quick Changer  
快换

Grip Module  
夹具组件

Air Nipper  
气动镊

Vacuum Module  
真空组件

Accessory Components  
附件

### QCSM-19R1

机器人侧模块  
Robot side module



货号(PN)	7.Y02123
型号(Model)	QCSM-19R1

- ※ 电压Voltage: 220V
- ※ 电流Current: 3A
- ※ 重量Weight: 309g
- ※ 适配于 Suitable for: QCA-35, QCA-50, QCA-S50, QCA-100, QCA-S100, QCA-S150, QCA-200, QCA-200-D1, QCA-300

### 注意事项

#### Points to note

1. 模块的安装, 必须固定到位, 避免造成针体的损坏, 导致信号传输不良
  2. 模块的更换, 必须在确保断电之后再进行操作
  3. 信号的传输过程中, 不要断开信号连接器
  4. 模块的维护, 定期使用毛刷清洁接触面
1. Module installation, must be fixed in place, to avoid causing damage to the needle lead to poor signal transmission
2. Module replacement, must ensure that the power cut after the operation
3. Do not disconnect the signal connector during signal transmission
4. Module maintenance, regular use of brush clean contact surface

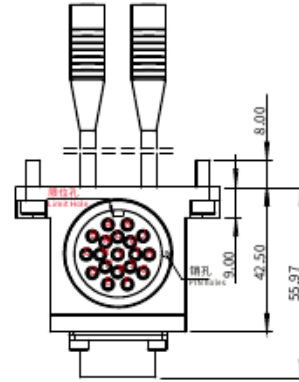
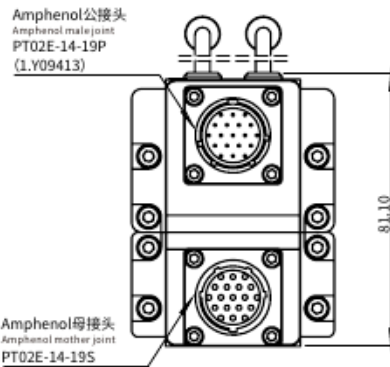
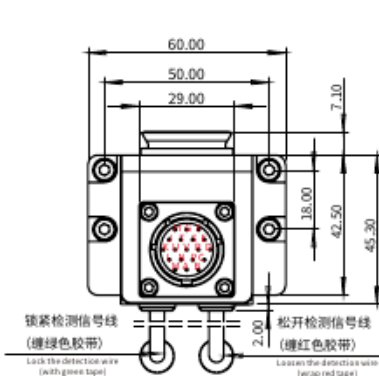

### 接线图/Wiring Diagram

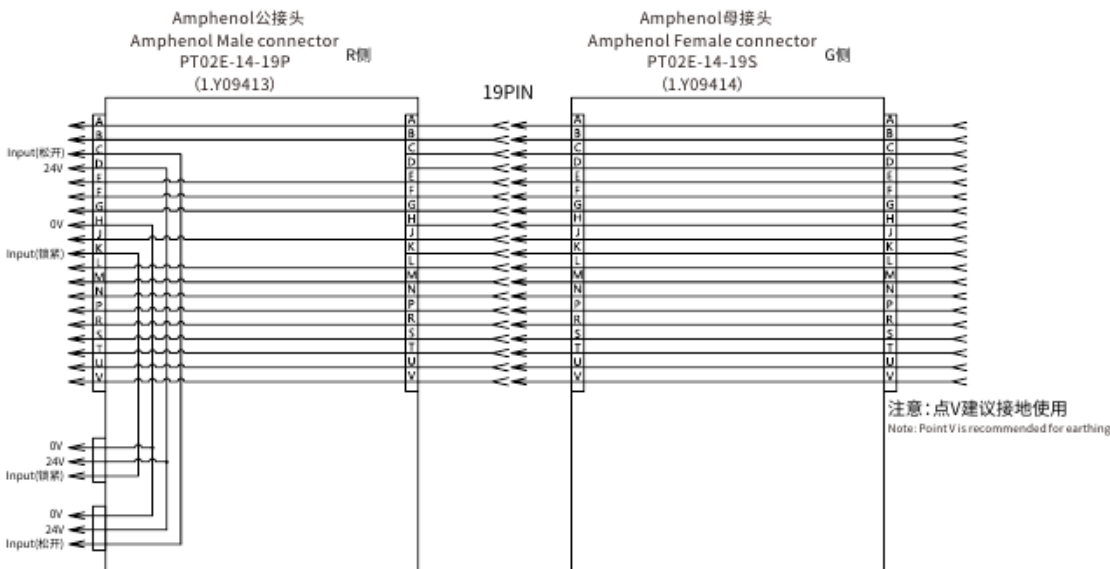

# 信号模块

## Signal Module

### QCSM-26R

机器人侧模块  
Robot side module



货号(PN)	7.Y00464
型号(Model)	QCSM-26R

- ※ 电压Voltage: 220V
- ※ 电流Current: 3A
- ※ 重量Weight: 198.5g
- ※ 适配于 Suitable for: QCA-35, QCA-50, QCA-S50, QCA-100, QCA-S100, QCA-S150, QCA-200, QCA-200-D1, QCA-300

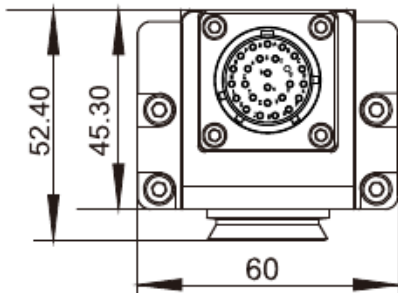
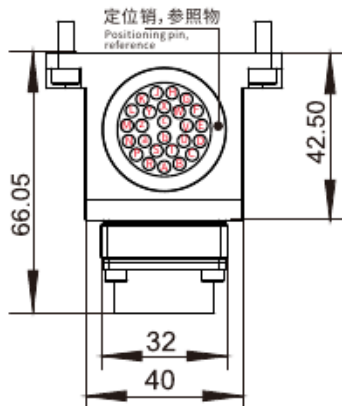

### QCSM-26G

夹具侧模块  
Gripper side module



货号(PN)	7.Y00465
型号(Model)	QCSM-26G

- ※ 电压Voltage: 220V
- ※ 电流Current: 3A
- ※ 重量Weight: 178.2g

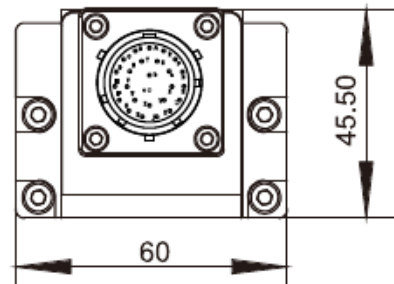
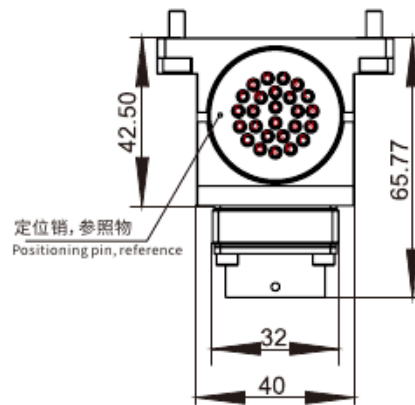

Profile、SUS Tube  
罩筒、钢管

Stents Module  
支架模组

Quick Changer  
快换

Grip Module  
夹具组件

Air Nipper  
气动镊

Vacuum Module  
真空组件

Accessory Components  
附件

# 信号模块

Signal Module

## QCSM-21/26G

夹具侧模块

Gripper side module



货号(PN)	7.Y02117
型号(Model)	QCSM-21/26G

※ 电压Voltage:220V

※ 电流Current:3A

※ 重量Weight:226g

※ 适配于 Suitable for: QCA-35, QCA-50, QCA-S50, QCA-100, QCA-S100, QCA-S150, QCA-200, QCA-200-D1, QCA-300

### 应用场景

#### Application scenarios

在一个设备使用多个工具(夹具)时,可以识别对应工具(夹具)的编码,可以有效防止工具的误用。

In a device using multiple tools (fixtures), you can identify the corresponding tools (fixtures) code, can effectively prevent tool misuse.

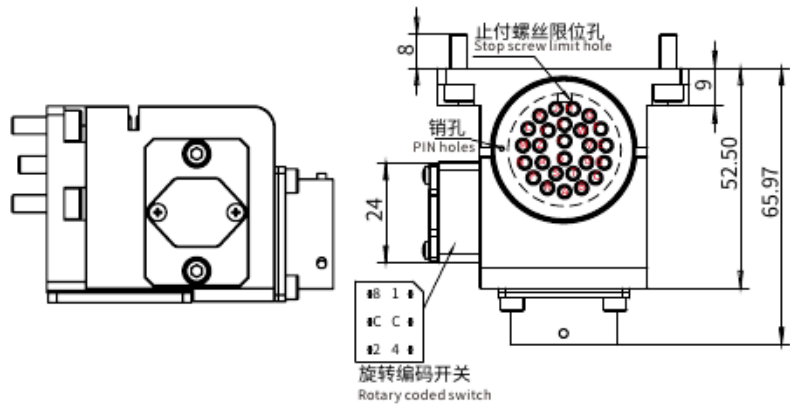
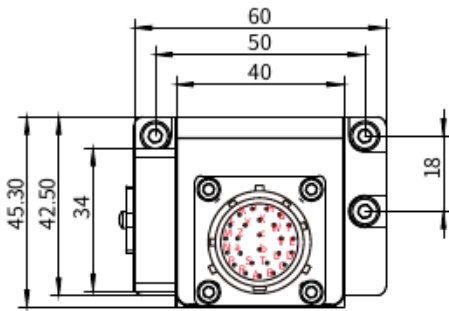

### 接线图/Wiring Diagram

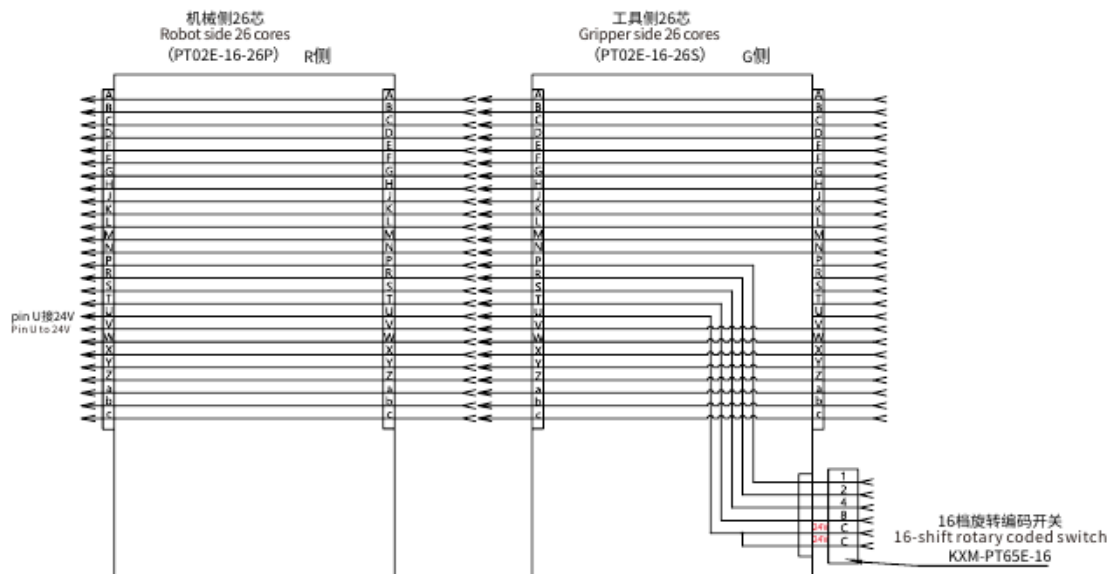

Profile- SUS Tube  
型材、钢管

Stents Module  
支架模组

Quick Changer  
快换

Gripper Module  
夹具组件

Air Nipper  
气动剪刀

Vacuum Module  
真空组件

Accessory Components  
附件

# 信号模块

## Signal Module

### QCSM-32R

机器人侧模块  
Robot side module



货号 (PN)	7.Y02095
型号 (Model)	QCSM-32R

- \* 铝合金防护外壳 Aluminum alloy protective housing
- \* 主盘松紧检测传感 Master disc tension detection sensor
- \* 电压Voltage: 220V
- \* 电流Current: 3A
- \* 重量Weight: 284g
- \* 适配于 Suitable for: QCA-35, QCA-50, QCA-S50, QCA-100, QCA-S100, QCA-S150, QCA-200, QCA-200-D1, QCA-300

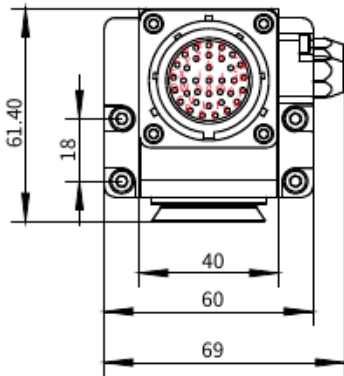
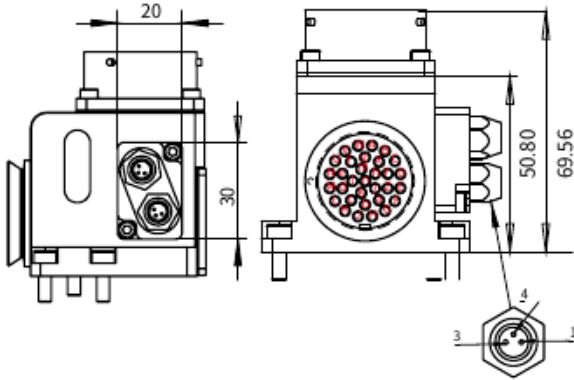

### QCSM-32G

夹具侧模块  
Gripper side module



货号 (PN)	7.Y02096
型号 (Model)	QCSM-32G

- \* 铝合金防护外壳 Aluminum alloy protective housing
- \* 主盘松紧检测传感 Master disc tension detection sensor
- \* 电压Voltage: 220V
- \* 电流Current: 3A
- \* 重量Weight: 227g

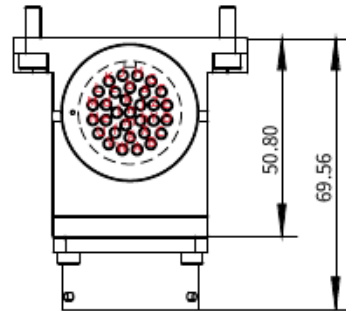
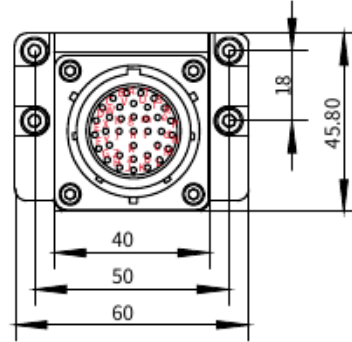

# 接线图/Wiring Diagram

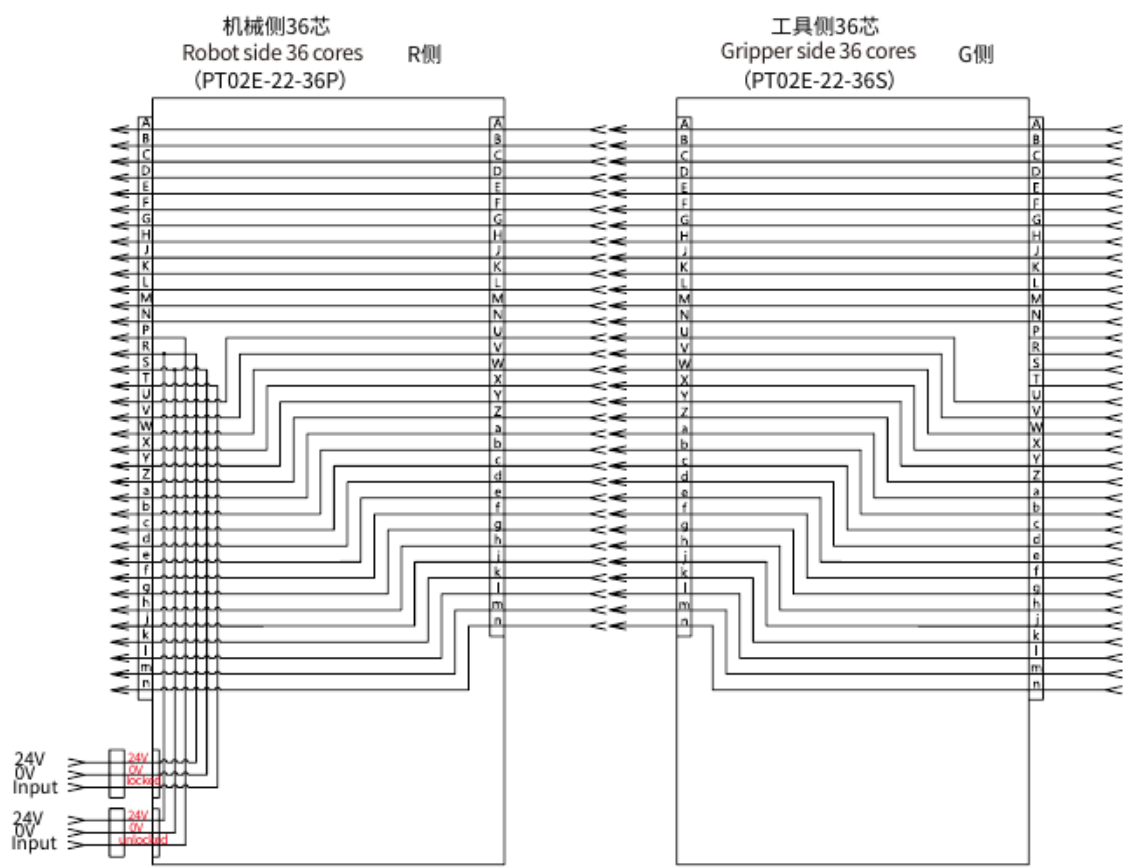

Profile, SUS Tube  
型材、钢管

Stents Module  
支架模组

Quick Changer  
快换

Gripper Module  
夹具组件

Air Nipper  
气动剪刀

Vacuum Module  
真空组件

Accessory Components  
附件

# 强电模块

## Power Module

### QCSM-08R

机器人侧模块  
Robot side module



货号(PN)	7.Y00477
型号(Model)	QCSM-08R

- ※ 电压Voltage: 380V
- ※ 电流Current: 20A
- ※ 重量Weight: 434.7g
- ※ 适配于 Suitable for: QCA-35, QCA-50, QCA-S50, QCA-100, QCA-S100, QCA-S150, QCA-200, QCA-200-D1, QCA-300

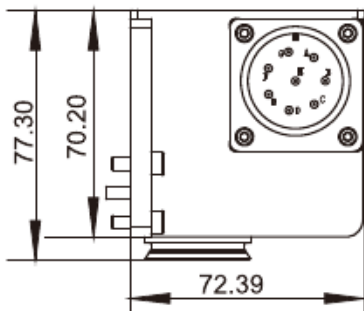
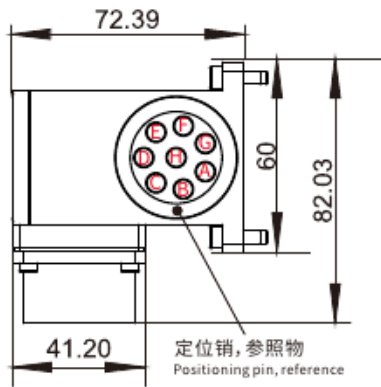

### QCSM-08G

夹具侧模块  
Gripper side module



货号(PN)	7.Y00478
型号(Model)	QCSM-08G

- ※ 电压Voltage: 380V
- ※ 电流Current: 20A
- ※ 重量Weight: 330g

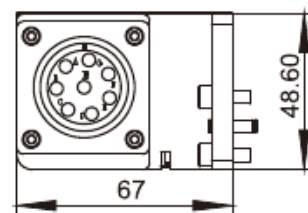
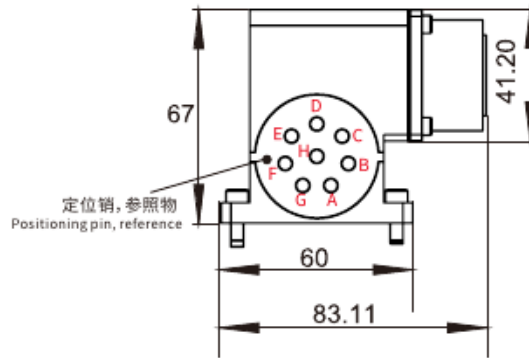

Profile、SUS Tube  
型材、钢管

Stents Module  
支架模组

Quick Changer  
快换

Grip Module  
夹具组件

Air Nipper  
气动剪刀

Vacuum Module  
真空组件

Accessory Components  
附件

# 强电模块

## Power Module

### QCSM-08R-1000

机器人侧模块  
Robot side module



货号(PN)	7.Y02084
型号(Model)	QCSM-08R-1000

- ※ 电压Voltage:380V
- ※ 电流Current:24A
- ※ 重量Weight:468g
- ※ 连接线线材长为1米(可定制) The wire's length is 1 meters(Customizable)
- ※ 适配于 Suitable for: QCA-05, QCA-15, QCA-25

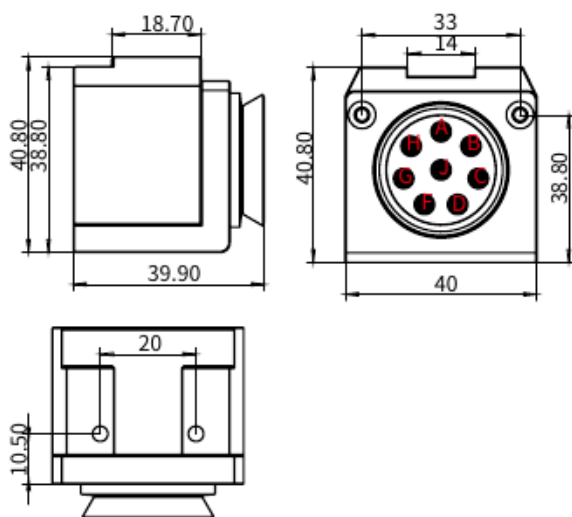

### QCSM-08G-1000

夹具侧模块  
Gripper side module



货号(PN)	7.Y02085
型号(Model)	QCSM-08G-1000

- ※ 电压Voltage:380V
- ※ 电流Current:24A
- ※ 重量Weight:487g

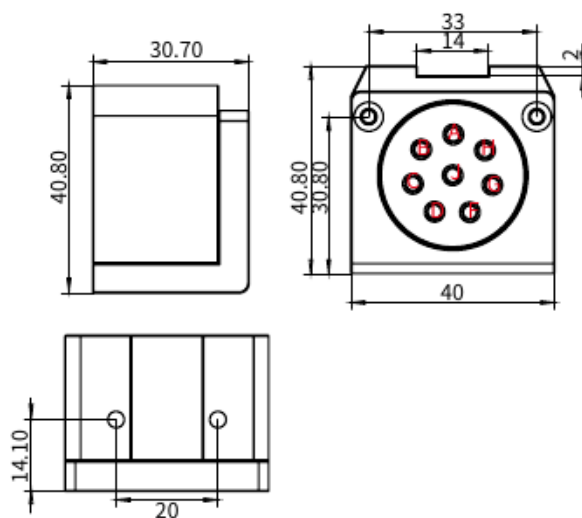

## 接线图/Wiring Diagram

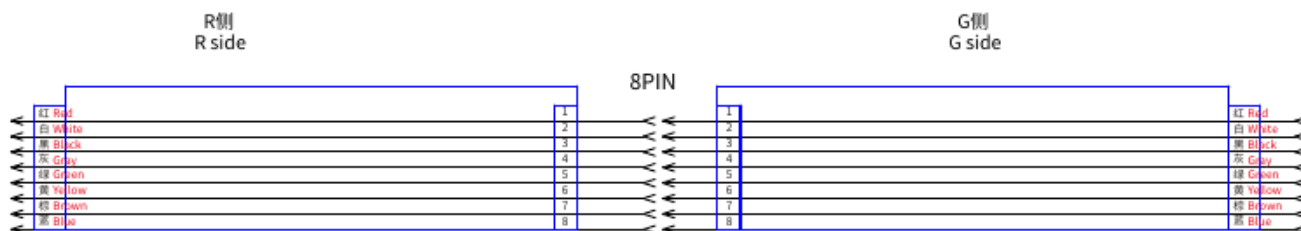

Profile、SUS Tube  
型材、钢管

Stents Module  
支架模组

Quick Changer  
快换

Gripper Module  
夹具组件

Air Nipper  
气动剪刀

Vacuum Module  
真空组件

Accessory Components  
附件

# 强电模块

## Power Module

### QCHFM-E14-C1R

机器人侧模块  
Robot side module



货号 (PN)	7.Y02003
型号 (Model)	QCHFM-E14-C1R

- \* 电压 Voltage: 1.4KV
- \* 电流 Current: 5A
- \* 重量 Weight: 194.5g
- \* 适配于 Suitable for: QCA-35, QCA-50, QCA-S50, QCA-100, QCA-S100, QCA-S150, QCA-200, QCA-200-D1, QCA-300

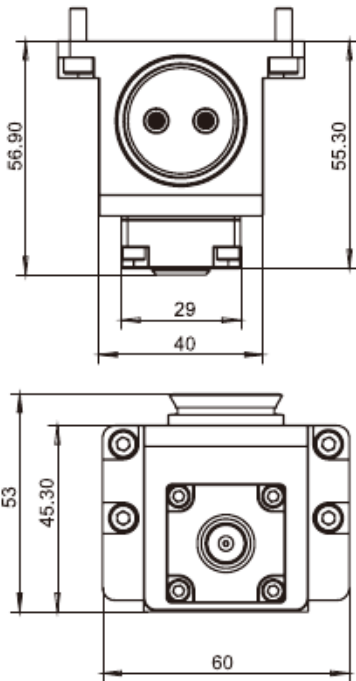

### QCHFM-E14-C1G

夹具侧模块  
Gripper side module



货号 (PN)	7.Y02004
型号 (Model)	QCHFM-E14-C1G

- \* 电压 Voltage: 1.4KV
- \* 电流 Current: 5A
- \* 重量 Weight: 151g

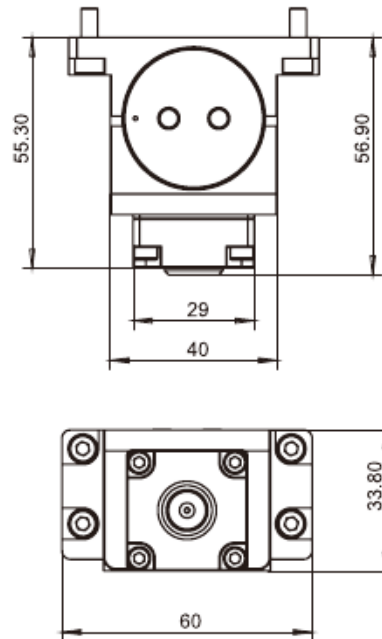

Profile, SUS Tube  
型材、钢管

Stents Module  
支架模组

Quick Changer  
快换

Grip Module  
夹具组件

Air Nipper  
气动剪刀

Vacuum Module  
真空组件

Accessory Components  
附件

# 强电模块

## Power Module

### QCHFМ-02R-1000

机器人侧模块  
Robot side module



货号(PN)	7.Y02086
型号(Model)	QCHFМ-02R-1000

- ※ 电压Voltage:1.4KV
- ※ 电流Current:5A
- ※ 重量Weight:138g
- ※ 连接线材长为1米(可定制) The wire's length is 1 meters(Customizable)
- ※ 适配于 Suitable for: QCA-05、QCA-15、QCA-25

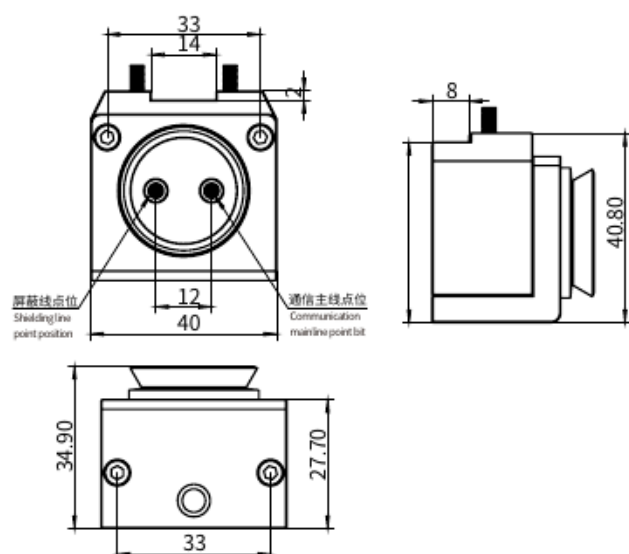

### QCHFМ-02G-1000

夹具侧模块  
Gripper side module



货号(PN)	7.Y02087
型号(Model)	QCHFМ-02G-1000

- ※ 电压Voltage:1.4KV
- ※ 电流Current:5A
- ※ 重量Weight:122g

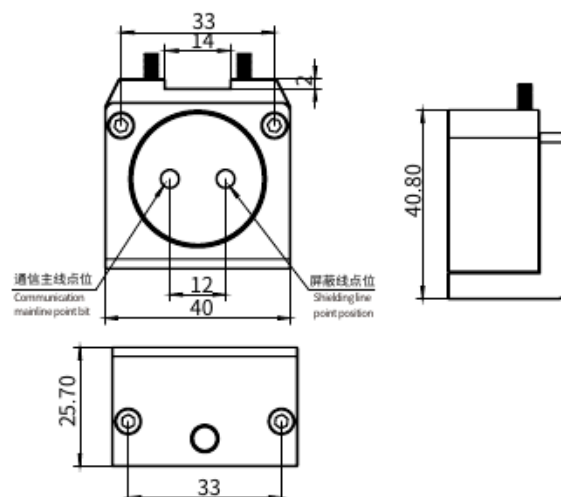

## 接线图/Wiring Diagram



型材、钢管  
Profile、SUS Tube

支架模组  
Stents Module

快换  
Quick Changer

夹具组件  
Grip Module

气动剪刀  
Air Nipper

真空组件  
Vacuum Module

附件  
Accessory Components

# 伺服模块

## Servo Module

### QCSM-08R1

机器人侧模块  
Robot side module



货号 (PN)	7.Y02080
型号 (Model)	QCSM-08R1

- ※ 20A\*4芯电流传输 20A\* 4-core current transmission
- ※ 2A\*2芯抱闸信号 2A\*2 core lock signal
- ※ 电压 Voltage: 24V
- ※ 重量 Weight: 310.5g
- ※ 适配于 Suitable for: QCA-35, QCA-50, QCA-S50, QCA-100, QCA-S100, QCA-S150, QCA-200, QCA-200-D1, QCA-300

### QCSM-08G1

夹具侧模块  
Gripper side module



货号 (PN)	7.Y02081
型号 (Model)	QCSM-08G1

- ※ 20A\*4芯电流传输 20A\* 4-core current transmission
- ※ 2A\*2芯抱闸信号 2A\*2 core lock signal
- ※ 电压 Voltage: 24V
- ※ 重量 Weight: 262.2g

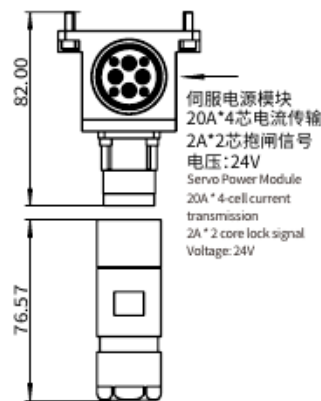
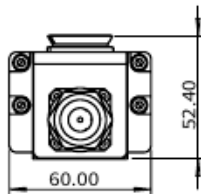

伺服电源模块  
20A\*4芯电流传输  
2A\*2芯抱闸信号  
电压: 24V  
Servo Power Module  
20A \* 4-cell current  
transmission  
2A \* 2 core lock signal  
Voltage: 24V

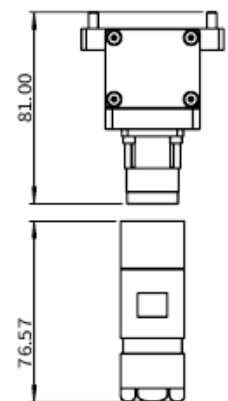
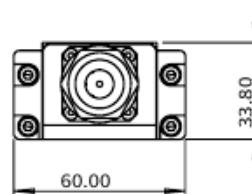

2 X Ø4-10L 销钉  
2x something 4-10l pin

4 X M4\*0.7-12L 螺丝  
4x M 4 \* 0.7-12L screws

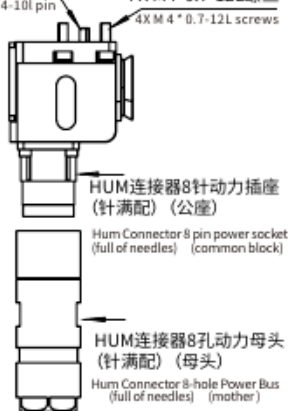

HUM连接器8针动力插座  
(针满配) (公座)  
Hum Connector 8 pin power socket  
(full of needles) (common block)

HUM连接器8孔动力母头  
(针满配) (母头)  
Hum Connector 8-hole Power Bus  
(full of needles) (mother)

2 X Ø4-10L 销钉  
2x something 4-10l pin

4 X M4\*0.7-12L 螺丝  
4x M 4 \* 0.7-12L screws

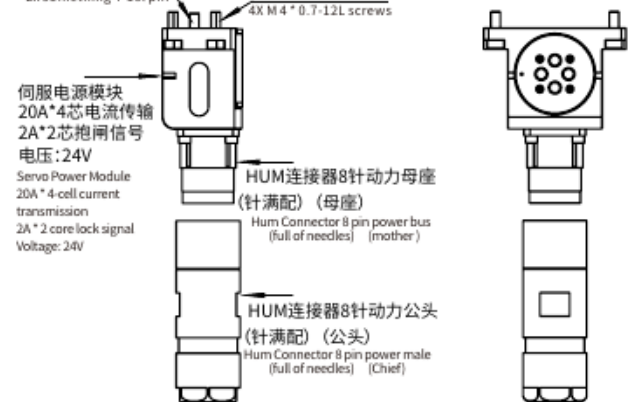

伺服电源模块  
20A\*4芯电流传输  
2A\*2芯抱闸信号  
电压: 24V  
Servo Power Module  
20A \* 4-cell current  
transmission  
2A \* 2 core lock signal  
Voltage: 24V

HUM连接器8针动力母座  
(针满配) (母座)  
Hum Connector 8 pin power bus  
(full of needles) (mother)

HUM连接器8针动力公头  
(针满配) (公头)  
Hum Connector 8 pin power male  
(full of needles) (Chief)

# 伺服模块

Servo Module

## QCSM-12R

机器人侧模块  
Robot side module



货号(PN)	7.Y02082
型号(Model)	QCSM-12R

- ※ 电压Voltage:24V
- ※ 2A\*9芯 2A \* 9 cores
- ※ 编码器信号传输 Encoder signal transmission
- ※ 重量Weight: 274.4g
- ※ 适配于 Suitable for: QCA-35, QCA-50, QCA-S50, QCA-100, QCA-S100, QCA-S150, QCA-200, QCA-200-D1, QCA-300

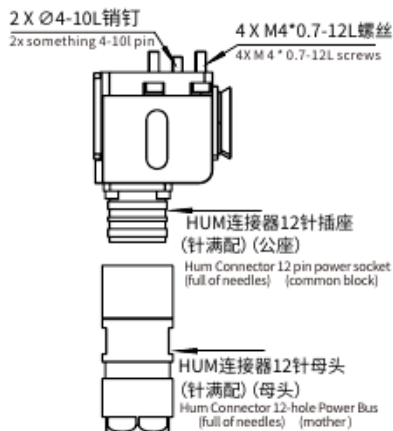
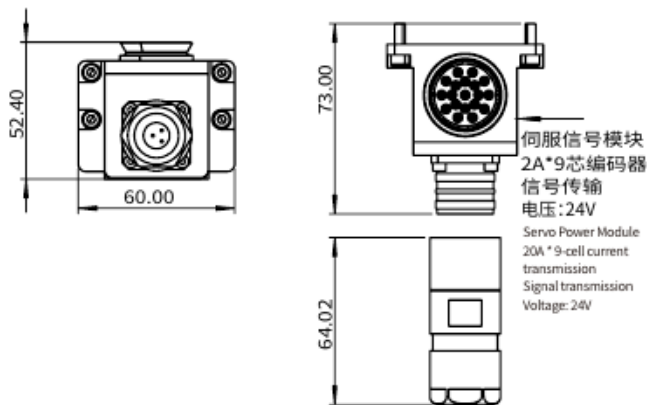

## QCSM-12G

夹具侧模块  
Gripper side module



货号(PN)	7.Y02083
型号(Model)	QCSM-12G

- ※ 电压Voltage:24V
- ※ 2A\*9芯 2A \* 9 cores
- ※ 编码器信号传输 Encoder signal transmission
- ※ 重量Weight: 219.4g

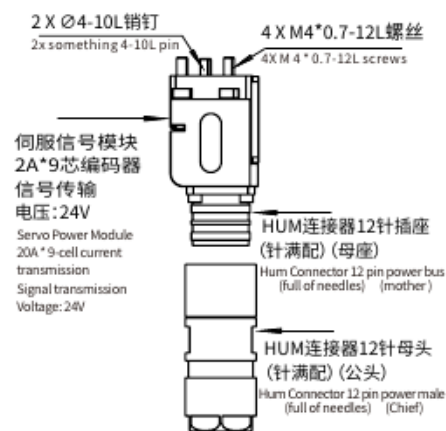
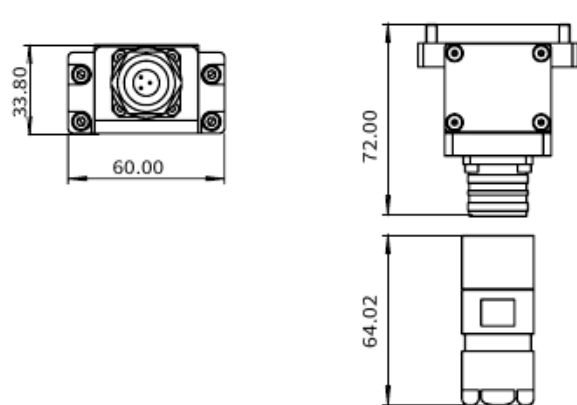

Profile- SUStube  
型材、钢管

Stents Module  
支架模组

Quick Changer  
快换

Grip Module  
夹具组件

Air Nipper  
气动剪刀

Vacuum Module  
真空组件

Accessory Components  
附件

# 伺服模块

## Servo Module

### QCSM-06/11R

机器人侧模块  
Robot side module



货号(PN)	7.Y02673
型号(Model)	QCSM-06/11R

- ※ 12A\*4芯电流传输 12A\* 4-core current transmission
- ※ 3A\*2芯抱闸信号 3A\*2 core lock signal
- ※ 2A\*10芯编码器信号传输 2A\*10 core encoder signal transmission
- ※ 重量Weight:287g
- ※ 适配于 Suitable for: QCA-35, QCA-50, QCA-S50, QCA-100, QCA-S100, QCA-S150, QCA-200, QCA-200-D1, QCA-300

### QCSM-06/11G

夹具侧模块  
Gripper side module



货号(PN)	7.Y02674
型号(Model)	QCSM-06/11G

- ※ 12A\*4芯电流传输 12A\* 4-core current transmission
- ※ 3A\*2芯抱闸信号 3A\*2 core lock signal
- ※ 2A\*10芯编码器信号传输 2A\*10 core encoder signal transmission
- ※ 电压Voltage:24V
- ※ 重量Weight:206g

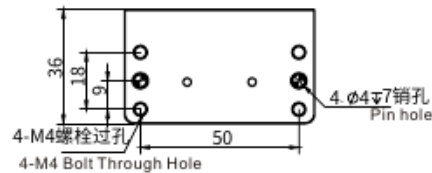
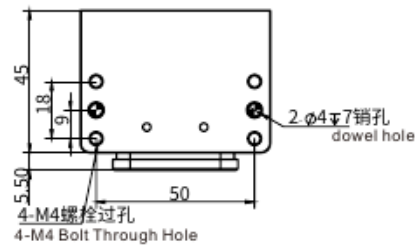
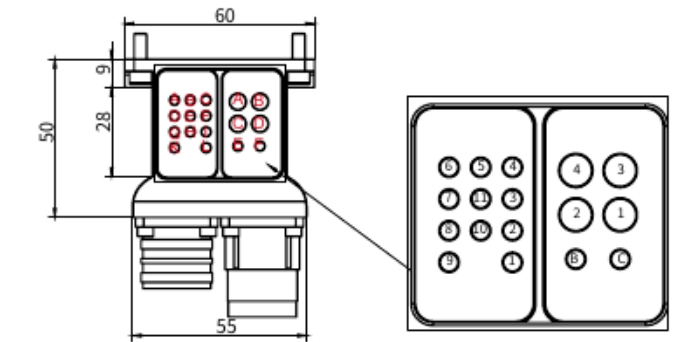
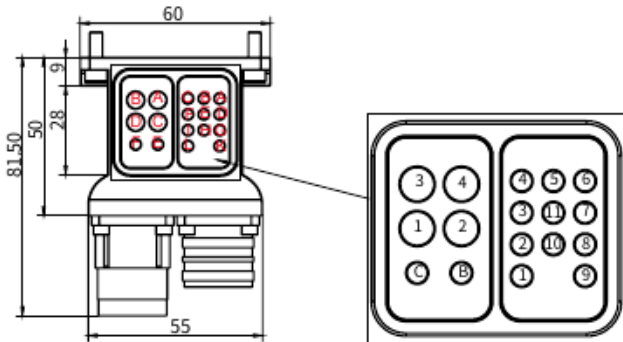

## 选配

### Optional

货号(PN)	型号(Model)	名称(Name)	
1.Y03689	H032008FY	HUM连接器 8孔动力母头(针满配)	R侧
1.Y03690	H032012EFY	HUM连接器 12孔母头(针满配)	
1.Y03691	H032008MY	HUM8芯动力内螺纹公头	G侧
1.Y03692	H032012PMY	HUM12芯内螺纹公头连接器	

# 伺服模块

Servo Module

## QCSM-06/11R1-5000

机器人侧模块  
Robot side module



货号(PN)	7.Y02675
型号(Model)	QCSM-06/11R1-5000

- ※ 12A\*4芯电流传输 12A\* 4-core current transmission
- ※ 3A\*2芯抱闸信号 3A\*2 core lock signal
- ※ 2A\*10芯编码器信号传输 2A\*10 core encoder signal transmission
- ※ 重量Weight:271g
- ※ 适配于 Suitable for: QCA-35, QCA-50, QCA-550, QCA-100, QCA-S100, QCA-S150, QCA-200, QCA-200-D1, QCA-300

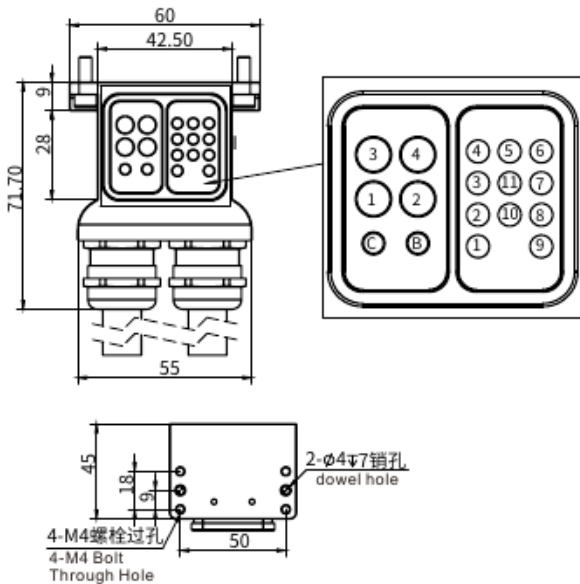

## QCSM-06/11G1-1000

夹具侧模块  
Gripper side module



货号(PN)	7.Y02676
型号(Model)	QCSM-06/11G1-1000

- ※ 12A\*4芯电流传输 12A\* 4-core current transmission
- ※ 3A\*2芯抱闸信号 3A\*2 core lock signal
- ※ 2A\*10芯编码器信号传输 2A\*10 core encoder signal transmission
- ※ 重量Weight:197g

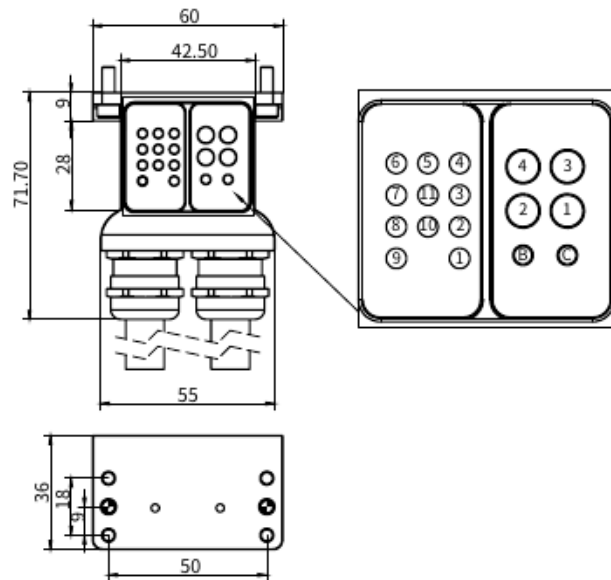

## 接线图/Wiring Diagram



Profile- SUS Tube  
型材、钢管

Stents Module  
支架模组

Quick Changer  
快换

Grip Module  
夹具组件

Air Nipper  
气动剪刀

Vacuum Module  
真空组件

Accessory Components  
附件

# 通讯模块

## Communication Module

### QCSM-RJ45-06R

机器人侧模块  
Robot side module



货号 (PN)	7.Y02007
型号 (Model)	QCSM-RJ45-06R

※ RJ45百兆网口 Rj45100 megabit network port  
 ※ 重量 Weight: 194.5g  
 ※ 适配于 Suitable for: QCA-35, QCA-50, QCA-S50, QCA-100, QCA-S100, QCA-S150, QCA-200, QCA-200-D1, QCA-300

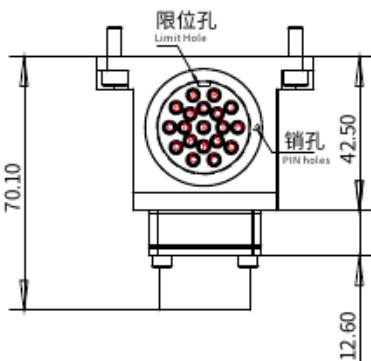
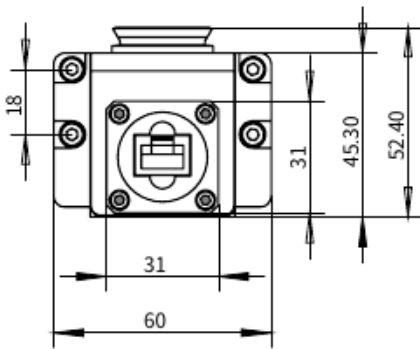

- 1, RJ45接口
- 2, RD稳定连接技术
- 3, 铝合金防护外壳

### QCSM-RJ45-06G

夹具侧模块  
Gripper side module



货号 (PN)	7.Y02008
型号 (Model)	QCSM-RJ45-06G

※ RJ45百兆网口 Rj45100 megabit network port  
 ※ 重量 Weight: 151g

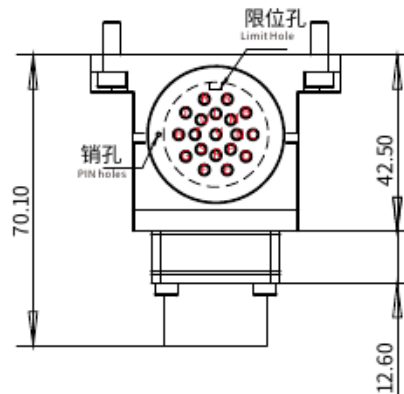
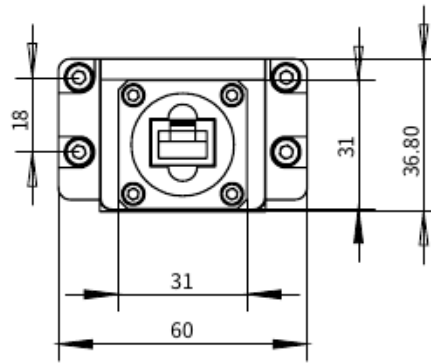

- 1, RJ45 interface
- 2, RD stable connection technology
- 3, Aluminum alloy protective shell

Profile、SUS Tube  
型材、钢管

Stents Module  
支架模组

Quick Changer  
快换

Grip Module  
夹具组件

Air Gripper  
气动夹刀

Vacuum Module  
真空组件

Accessory Components  
附件

# 接线图/Wiring Diagram

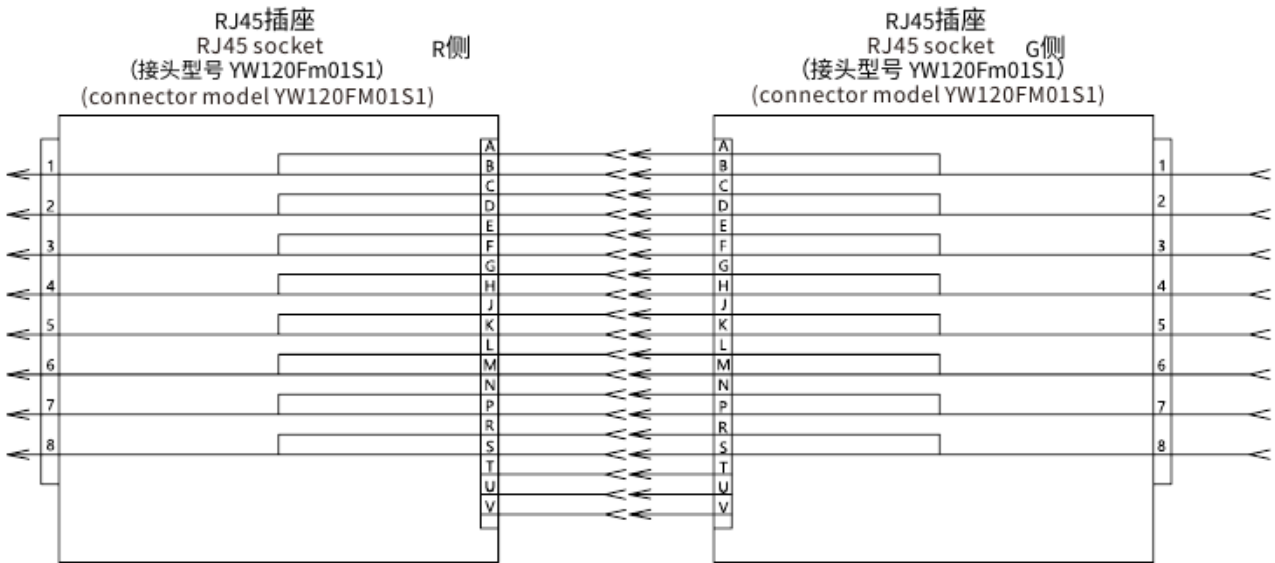

## 选配

Optional



### RJ45网络接口

RJ45 network interface

货号(PN)	1.Y13684
型号(Model)	YM110Fm01S1-01

Profile、SUS Tube  
型材、钢管

Stents Module  
支架模组

Quick Changer  
快换

Grip Module  
夹具组件

Air Nipper  
气动剪刀

Vacuum Module  
真空组件

Accessory Components  
附件

# 通讯模块

## Communication Module

### QCSM-RJ45-1M-06R

机器人侧模块  
Robot side module



货号(PN)	7.Y02129
型号(Model)	QCSM-RJ45-1M-06R

- ※ 电压Voltage: 220V
- ※ 电流Current: 3A
- ※ 重量Weight: 237g
- ※ 连接线材长为1米(可定制) The wire's length is 1 meters(Customizable)
- ※ 适配于 Suitable for: QCA-05, QCA-15, QCA-25

### QCSM-RJ45-1M-06G

夹具侧模块  
Gripper side module



货号(PN)	7.Y02130
型号(Model)	QCSM-RJ45-1M-06G

- ※ 电压Voltage: 220V
- ※ 电流Current: 3A
- ※ 重量Weight: 221g.

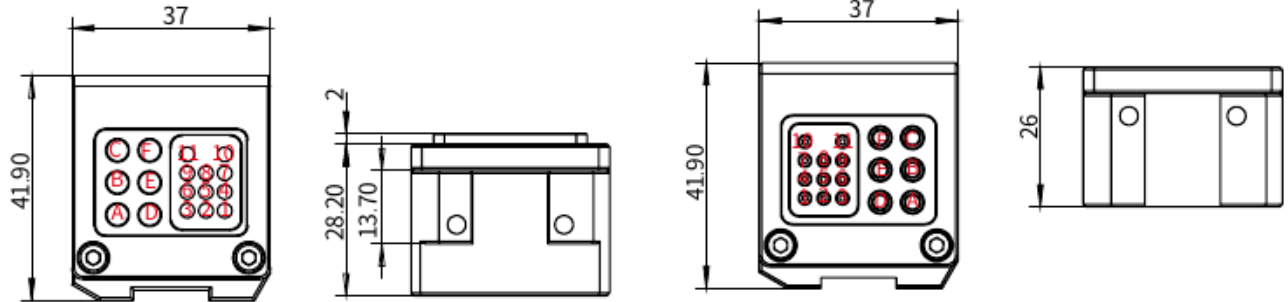

## 接线图/Wiring Diagram

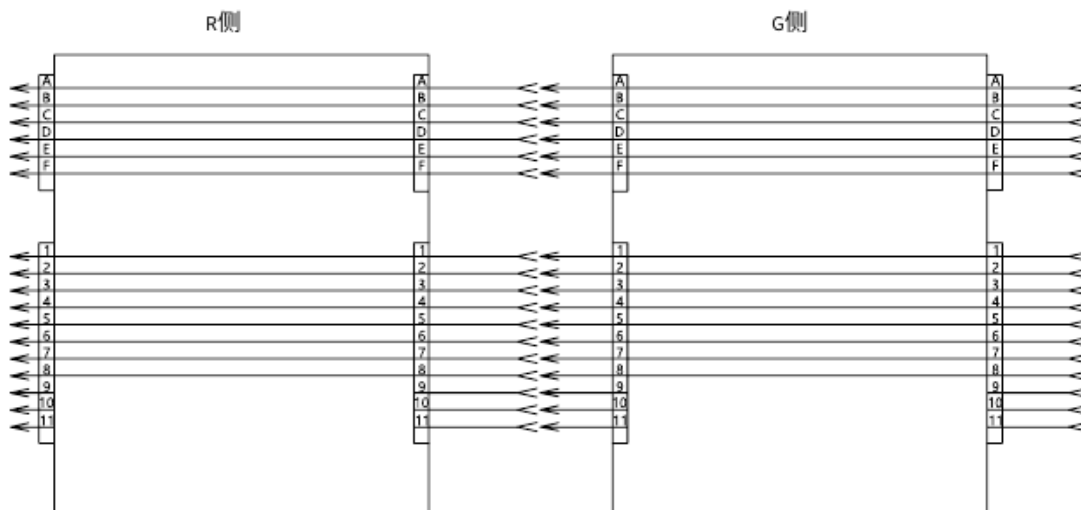

Profile、SUS Tube  
型材、钢管

Stents Module  
支架模组

Quick Changer  
快换

Grip Module  
夹具组件

Air Gripper  
气动夹刀

Vacuum Module  
真空组件

Accessory Components  
附件

# 通讯模块

## Communication Module

### QCSM-05G7/8-04G7/8-10R

机器人侧模块  
Robot side module



货号(PN)	7.Y02115
型号(Model)	QCSM-05G7/8-04G7/8-10R

- ※ 电压Voltage:220V
- ※ 电流 Current:3A
- ※ Ethernet网线(7/8-4)
- ※ 重量 Weight:576g
- ※ 适配于 Suitable for : QCA-35, QCA-50, QCA-S50, QCA-100, QCA-S100, QCA-S150, QCA-200, QCA-200-D1, QCA-300

### QCSM-05G7/8-04G7/8-10G

夹具侧模块  
Gripper side module



货号(PN)	7.Y02075
型号(Model)	QCSM-05G7/8-04G7/8-10G

- ※ 电压Voltage:220V
- ※ 电流 Current:3A
- ※ Ethernet网线(7/8-4)
- ※ 重量 Weight:428g

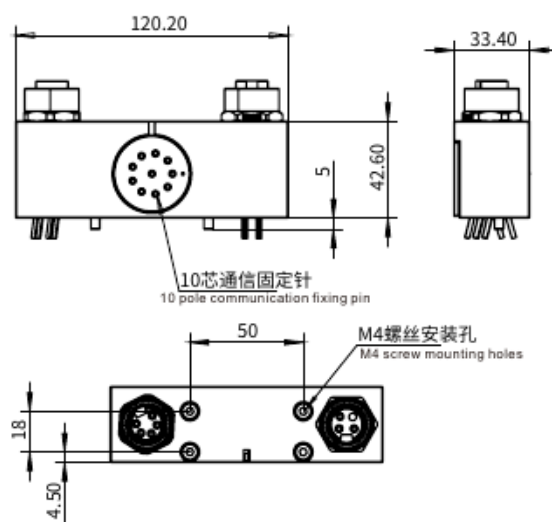
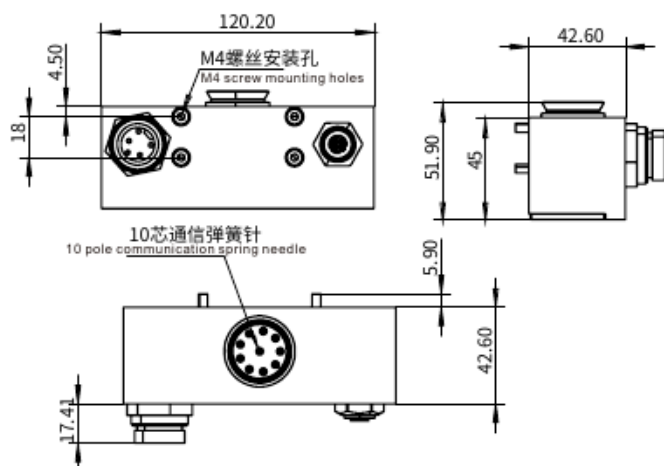

Profile- SUS Tube  
型材、钢管

Stents Module  
支架模组

Quick Changer  
快换

Grip Module  
夹具组件

Air Nipper  
气动剪刀

Vacuum Module  
真空组件

Accessory Components  
附件

# 通讯模块

## Communication Module

### QCSM-05G7/8-04M12-10R

机器人侧模块  
Robot side module



货号(PN)	7.Y02118
型号(Model)	QCSM-05G7/8-04M12-10R

- ※ 电压Voltage: 220V
- ※ 电流 Current: 3A
- ※ Profinet网线(M12-4)
- ※ 重量 Weight: 500g
- ※ 适配于 Suitable for: QCA-35, QCA-50, QCA-S50, QCA-100, QCA-S100, QCA-S150, QCA-200, QCA-200-D1, QCA-300

### QCSM-05G7/8-04M12-10G

夹具侧模块  
Gripper side module



货号(PN)	7.Y02119
型号(Model)	QCSM-05G7/8-04M12-10G

- ※ 电压Voltage: 220V
- ※ 电流 Current: 3A
- ※ Profinet网线(M12-4)
- ※ 重量 Weight: 500g

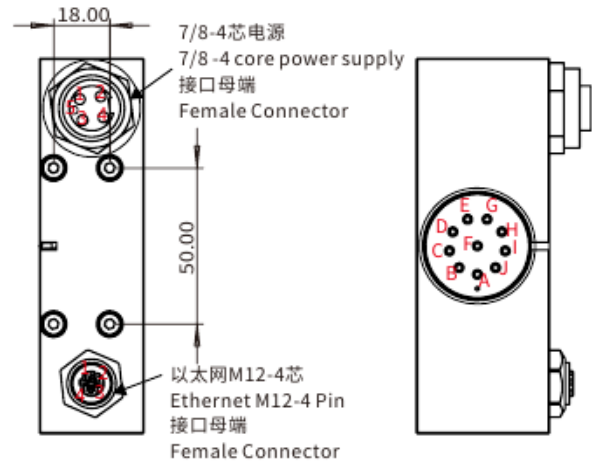
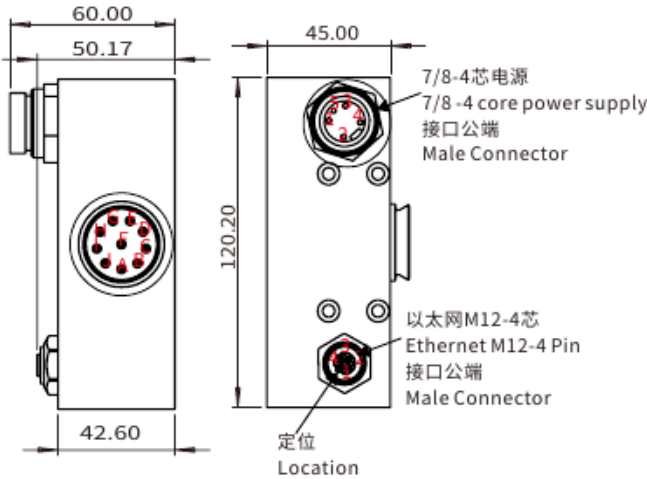

Profile, SUS Tube  
型材、钢管

Stents Module  
支架模组

Quick Changer  
快换

Grip Module  
夹具组件

Air Gripper  
气动夹刀

Vacuum Module  
真空组件

Accessory Components  
附件

# 气路模块

Pneumatic Module

NEW

## QCAM-01G2R

机器人侧模块  
Robot side module



货号(PN)	7.Y03893
型号(Model)	QCAM-01G2R

- ※ 2寸大流量真空模块 2-inch High-Flow Vacuum Module
- ※ 铝合金防护外壳 Aluminum alloy protective enclosure
- ※ 重量Weight: 460g
- ※ 适配于 Suitable for: QCA-S150, QCA-200, QCA-200-D1

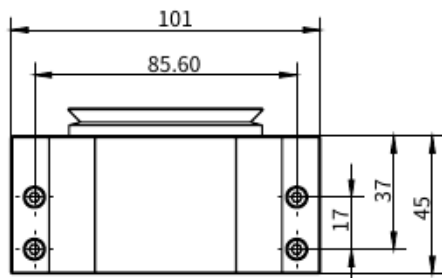
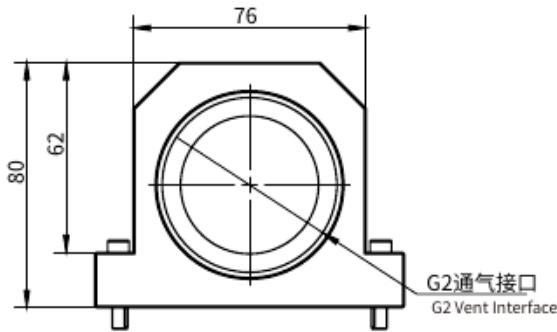

## QCAM-01G2G

夹具侧模块  
Gripper side module

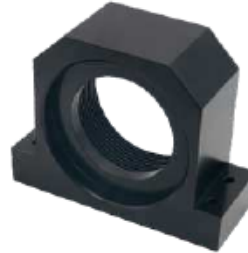

货号(PN)	7.Y03894
型号(Model)	QCAM-01G2G

- ※ 2寸大流量真空模块 2-inch High-Flow Vacuum Module
- ※ 铝合金防护外壳 Aluminum alloy protective enclosure
- ※ 重量Weight: 369g

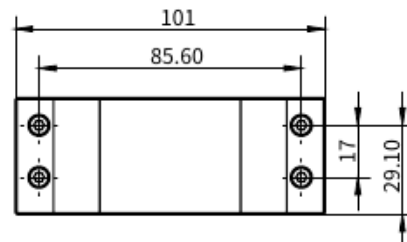
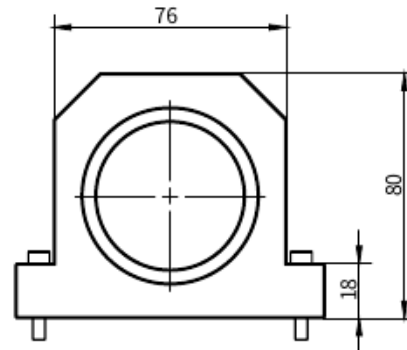

Profile、SUS Tube  
型材、钢管

Stents Module  
支架模组

Quick Changer  
快换

Grip Module  
夹具组件

Air Nipper  
气动剪刀

Vacuum Module  
真空组件

Accessory Components  
附件

# 气路模块

## Pneumatic Module

### QCAM-06G18R

机器人侧模块  
Robot side module



货号(PN)	7.Y01015
型号(Model)	QCAM-06G18R

※重量Weight:141.4g  
 ※适配于 Suitable for: QCA-35, QCA-50, QCA-550, QCA-100, QCA-S100, QCA-S150, QCA-200, QCA-200-D1, QCA-300

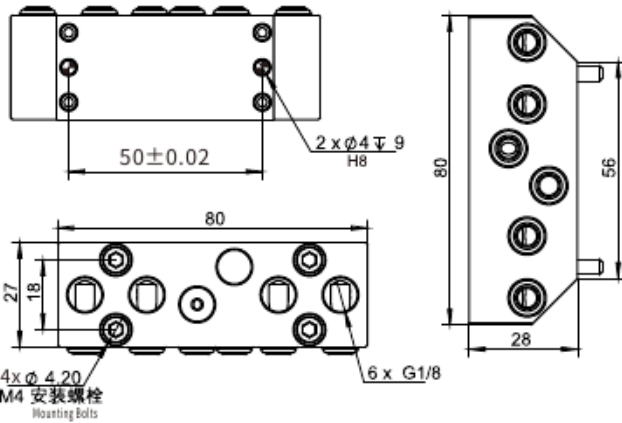

### QCAM-06G18G

夹具侧模块  
Gripper side module



货号(PN)	7.Y01016
型号(Model)	QCAM-06G18G

※重量Weight:140.9g

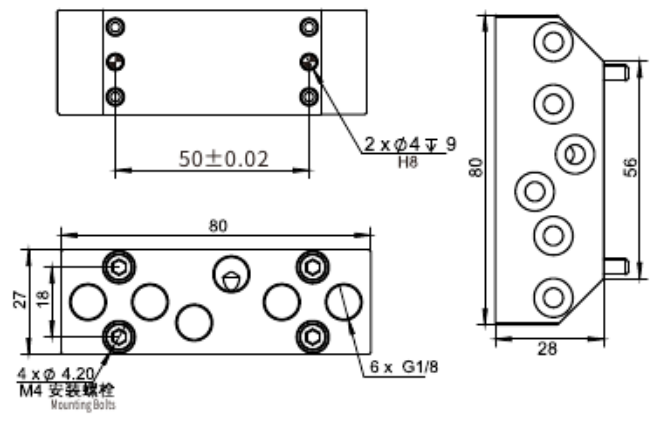

Profile, SUS Tube  
型材、钢管

Stents Module  
支架模组

Quick Changer  
快换

Grip Module  
夹具组件

Air Gripper  
气动夹刀

Vacuum Module  
真空组件

Accessory Components  
附件

# 气路模块

## Pneumatic Module

### QCAM-06G18R-E

机器人侧模块  
Robot side module



货号(PN)	7.Y01018
型号(Model)	QCAM-06G18R-E

※ 重量Weight: 145g

※ 适配于 Suitable for: QCA-35, QCA-50, QCA-S50, QCA-100, QCA-S100, QCA-S150, QCA-200, QCA-200-D1, QCA-300

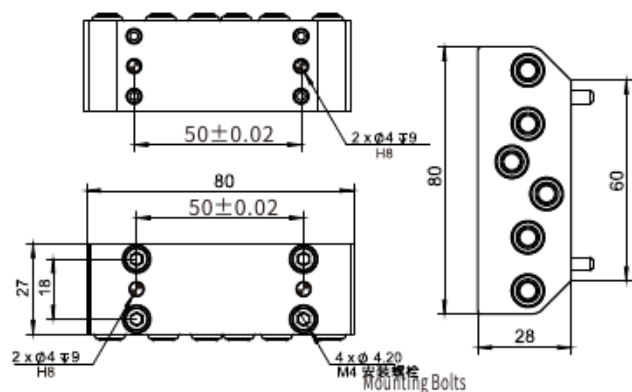

### QCAM-06G18G-E

夹具侧模块  
Gripper side module



货号(PN)	7.Y01019
型号(Model)	QCAM-06G18G-E

※ 重量Weight: 148g

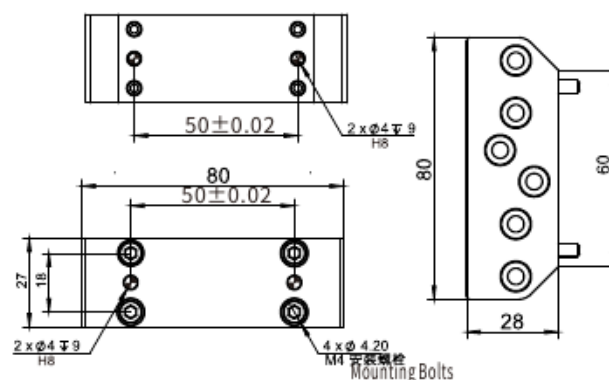

Profile- SUS Tube  
型材、钢管

Stents Module  
支架模组

Quick Changer  
快换

Grip Module  
夹具组件

Air Nipper  
气动剪刀

Vacuum Module  
真空组件

Accessory Components  
附件

# 气路模块-自密封

Pneumatic Module-Self-sealing

## QCAM-06G18R-F

机器人侧模块  
Robot side module



货号(PN)	7.Y02005
型号(Model)	QCAM-06G18R-F

※重量 Weight: 150g  
 ※适配于 Suitable for: QCA-35, QCA-50, QCA-S50, QCA-100, QCA-S100, QCA-S150, QCA-200, QCA-200-D1, QCA-300

## QCAM-06G18G-F

夹具侧模块  
Gripper side module



货号(PN)	7.Y02006
型号(Model)	QCAM-06G18G-F

※重量 Weight: 152g

Profile, SUS Tube  
型材、钢管

Stents Module  
支架模组

Quick Changer  
快换

Grip Module  
夹具组件

Air Nipper  
气动剪刀

Vacuum Module  
真空组件

Accessory Components  
附件

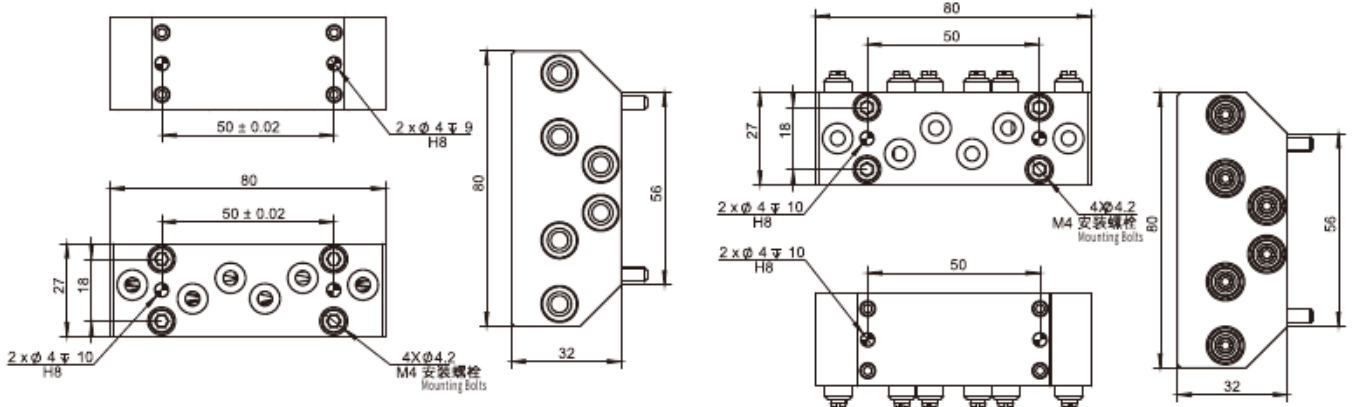

# 气路模块

Pneumatic Module

## QCAM-10M5R

机器人侧模块  
Robot side module



货号 (PN)	7.Y01053
型号 (Model)	QCAM-10M5R

※重量 Weight: 263.9g

※适配于 Suitable for: QCA-100, QCA-S100, QCA-S150, QCA-200, QCA-200-D1, QCA-300

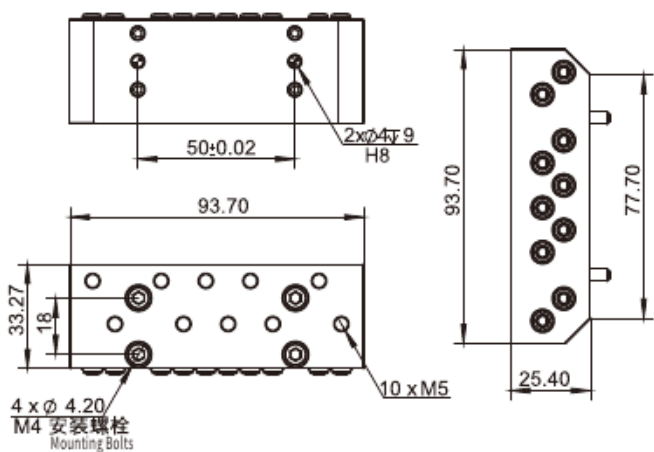

## QCAM-10M5G

夹具侧模块  
Gripper side module



货号 (PN)	7.Y01054
型号 (Model)	QCAM-10M5G

※重量 Weight: 267.9g

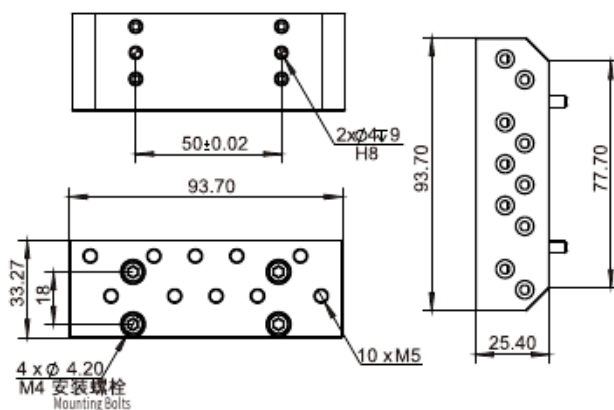

Profile- SUS Tube  
型材、钢管

Stents Module  
支架模组

Quick Changer  
快换

Grip Module  
夹具组件

Air Nipper  
气动剪刀

Vacuum Module  
真空组件

Accessory Components  
附件

# 气路模块

## Pneumatic Module

### QCAM-14M5R

机器人侧模块  
Robot side module



货号 (PN)	7.Y01055
型号 (Model)	QCAM-14M5R

※ 重量 Weight: 207.4g  
 ※ 适配于 Suitable for: QCA-S100, QCA-S150, QCA-200, QCA-200-D1, QCA-300

### QCAM-14M5G

夹具侧模块  
Gripper side module



货号 (PN)	7.Y01056
型号 (Model)	QCAM-14M5G

※ 重量 Weight: 210.3g

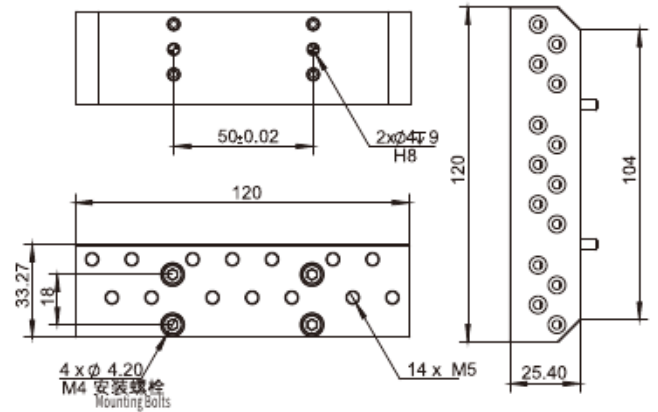
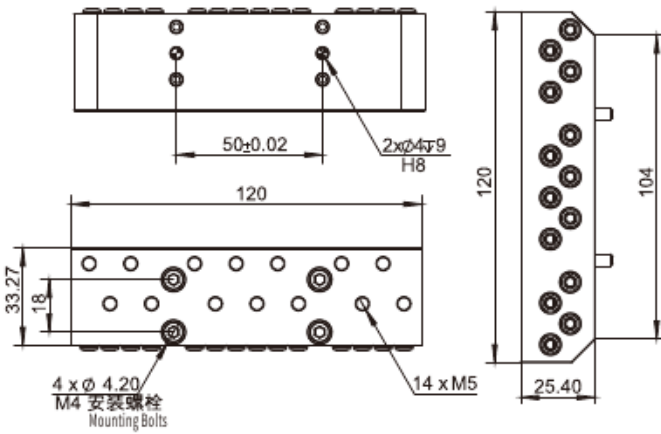

Profile、SUS Tube  
型材、钢管

Stents Module  
支架模组

Quick Changer  
快换

Grip Module  
夹具组件

Air Gripper  
气动夹刀

Vacuum Module  
真空组件

Accessory Components  
附件

# 气路模块

Pneumatic Module

## QCAM-04G38R

机器人侧模块  
Robot side module



货号(PN)	7.Y02043
型号(Model)	QCAM-04G38R

※重量 Weight:242g

※适配于 Suitable for: QCA-100, QCA-S100, QCA-S150, QCA-200, QCA-200-D1, QCA-300

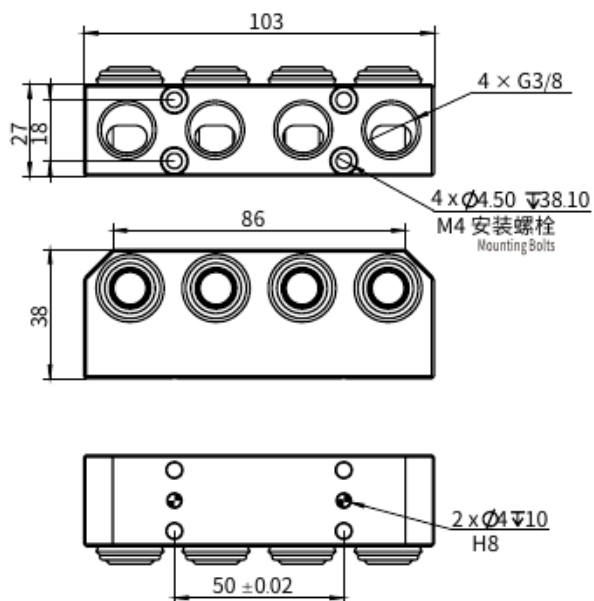

## QCAM-04G38G

夹具侧模块  
Gripper side module



货号(PN)	7.Y02044
型号(Model)	QCAM-04G38G

※重量 Weight:213.4g

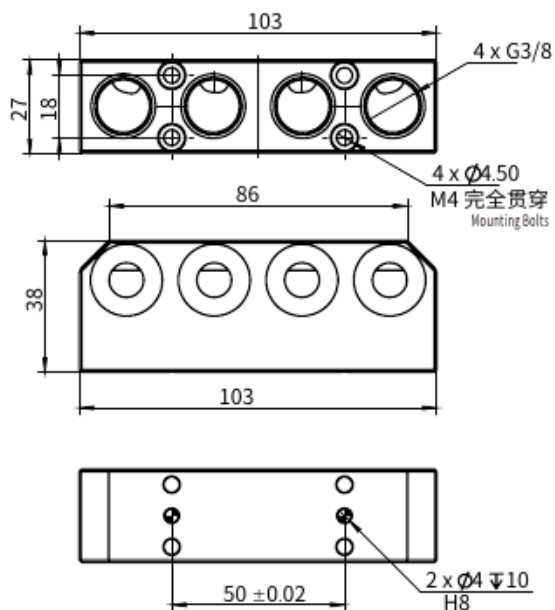

Profile、SUS Tube  
型材、钢管

Stents Module  
支架模组

Quick Changer  
快换

Grip Module  
夹具组件

Air Nipper  
气动剪刀

Vacuum Module  
真空组件

Accessory Components  
附件

# 水气模块

## Water-Pneumatic Module

### QCWM-02R

机器人侧模块  
Robot side module



货号 (PN)	7.Y02049
型号 (Model)	QCWM-02R

※ 材质 Material: 不锈钢外壳 Stainless steel housing  
 ※ 重量 Weight: 393.6g  
 ※ 适配于 Suitable for: QCA-35, QCA-50, QCA-S50, QCA-100, QCA-S100, QCA-S150, QCA-200, QCA-200-D1, QCA-300

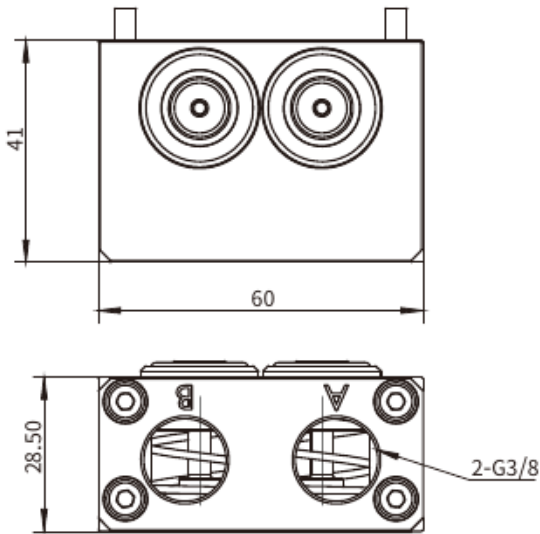

### QCWM-02G

夹具侧模块  
Gripper side module



货号 (PN)	7.Y02050
型号 (Model)	QCWM-02G

※ 材质 Material: 不锈钢外壳 Stainless steel housing  
 ※ 重量 Weight: 379g

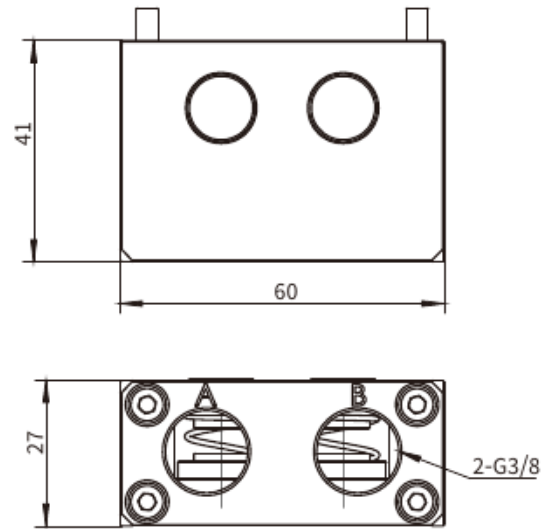

Profile, SUS Tube  
型材、钢管

Stents Module  
支架模组

Quick Changer  
快换

Grip Module  
夹具组件

Air Gripper  
气动夹刀

Vacuum Module  
真空组件

Accessory Components  
附件

# 快换信号线

Quick changer signal cable

## DB15R1-1000

15芯快换信号线(母头)

15 core quick changer signal cable (female head)



货号(PN)	1.Y10163
型号(Model)	DB15R1-1000

※ 重量Weight:125.7g

※ 连接线线材长为1米 The wire's length is 1 meters

※ 适配于 Suitable for: QCSM-15R1

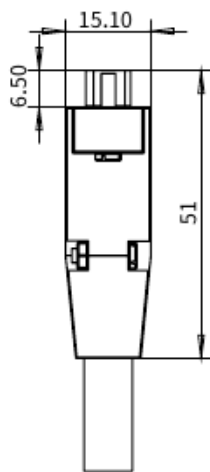
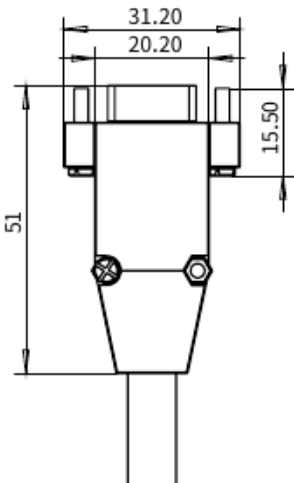
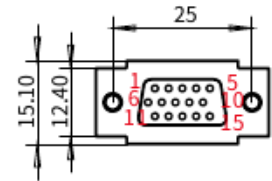

## DB15G1-1000

15芯快换信号线(公头)

15 core quick changer signal cable (male head)



货号(PN)	1.Y10437
型号(Model)	DB15G1-1000

※ 重量Weight:123.7g

※ 连接线线材长为1米 The wire's length is 1 meters

※ 适配于 Suitable for: QCSM-15G1

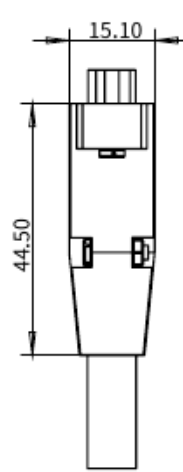
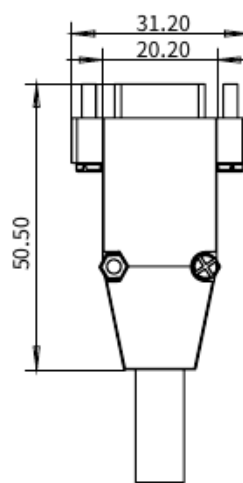
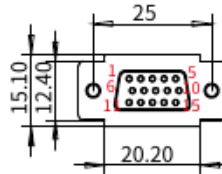

Profile- SUStube  
型材、钢管

Stents Module  
支架模组

Quick Changer  
快换

Grip Module  
夹具组件

Air Nipper  
气动剪刀

Vacuum Module  
真空组件

Accessory Components  
附件

# 快换信号线

Quick changer signal cable

## D-Sub15R2-1000

15芯快换信号线(母头)

15 core quick changer signal cable (female head)



货号(PN)	1.Y10080
型号(Model)	D-Sub15R2-1000

- ※ 重量Weight: 142g
- ※ 连接线线材长为1米 The wire's length is 1 meters
- ※ 适配于 Suitable for: QCSM-15R2

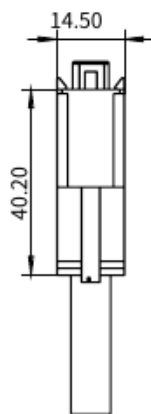
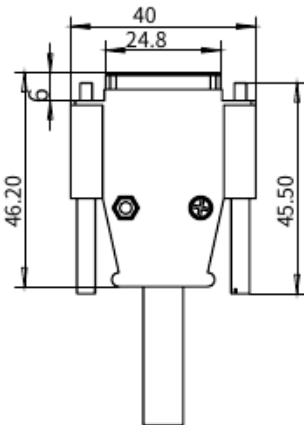
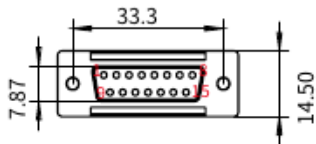

## D-Sub15G2-1000

15芯快换信号线(公头)

15 core quick changer signal cable (male head)



货号(PN)	1.Y10081
型号(Model)	D-Sub15G2-1000

- ※ 重量Weight: 141.4g
- ※ 连接线线材长为1米 The wire's length is 1 meters
- ※ 适配于 Suitable for: QCSM-15G2

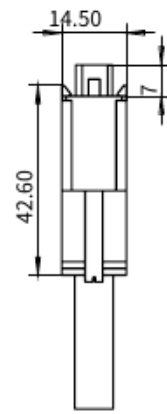
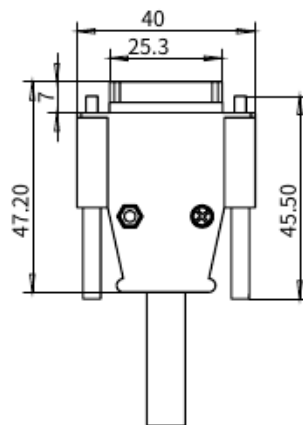
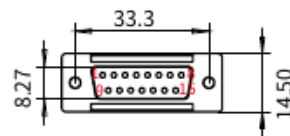

Profile、SUS Tube  
型材、钢管

Stents Module  
支架模组

Quick Changer  
快换

Grip Module  
夹具组件

Air Nipper  
气动剪

Vacuum Module  
真空组件

Accessory Components  
附件

# 90°接头

## 90°Connector

### CMB08E-14-19S(072)SR-B

19芯90°接头(母头)

19 core 90° connector (female head)



货号(PN)	1.Y11863
型号(Model)	CMB08E-14-19S(072)SR-B

※重量 Weight:81.1g

※适配于 Suitable for:QCSM-19R, QCSM-19R1

### CMB08E-14-19P(072)SR-B

19芯90°接头(公头)

19 core 90° connector (male head)



货号(PN)	1.Y11864
型号(Model)	CMB08E-14-19P(072)SR-B

※重量 Weight:79.2g

※适配于 Suitable for:QCSM-19G

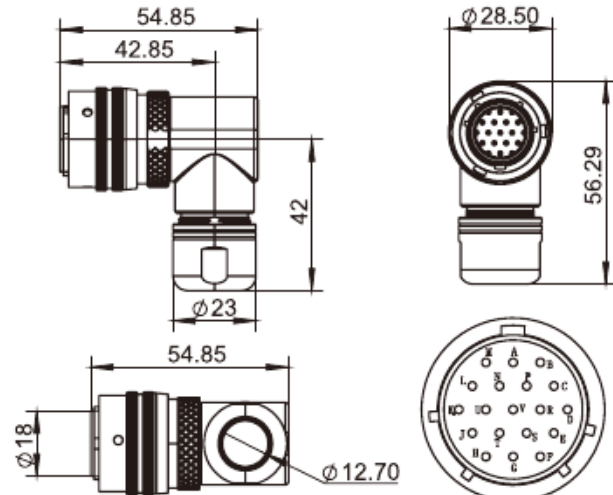
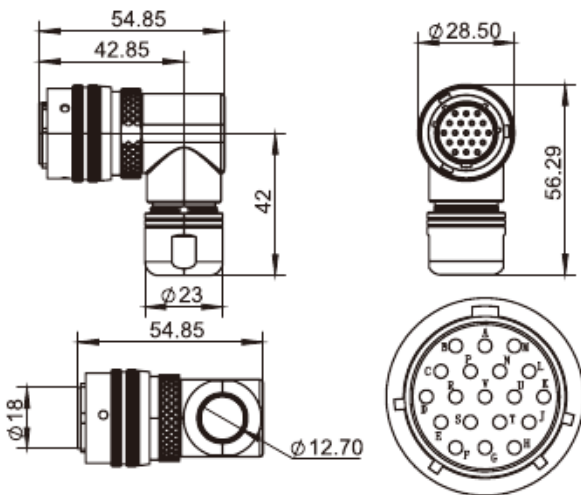

Profile、SUSTube  
型材、钢管

Stents Module  
支架模组

Quick Changer  
快换

Grip Module  
夹具组件

Air Nipper  
气动剪刀

Vacuum Module  
真空组件

Accessory Components  
附件

# 90°接头

## 90° Connector

### CMB08E-16-26S(072)SR-B

26芯90°接头(母头)  
26 core 90° connector (female head)



货号(PN)	1.Y11865
型号(Model)	CMB08E-16-26S(072)SR-B

※ 重量 Weight: 99.5g  
※ 适配于 Suitable for: QCSM-26R

### CMB08E-16-26P(072)SR-B

26芯90°接头(公头)  
26 core 90° connector (male head)



货号(PN)	1.Y11866
型号(Model)	CMB08E-16-26P(072)SR-B

※ 重量 Weight: 96.4g  
※ 适配于 Suitable for: QCSM-21/26G, QCSM-26G

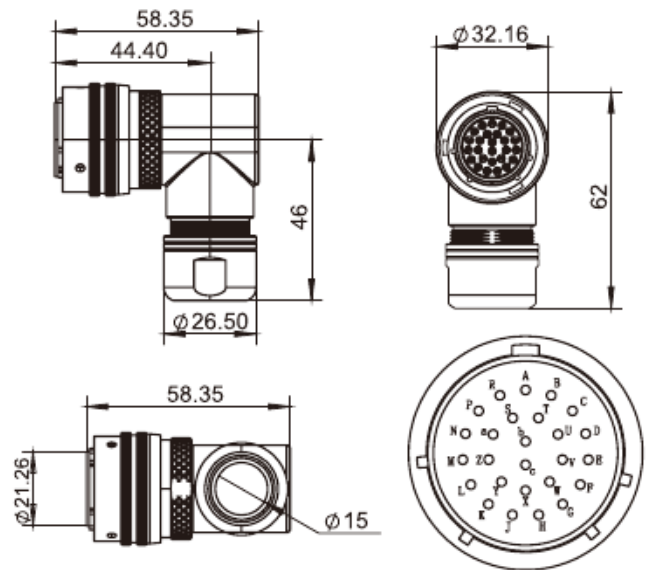
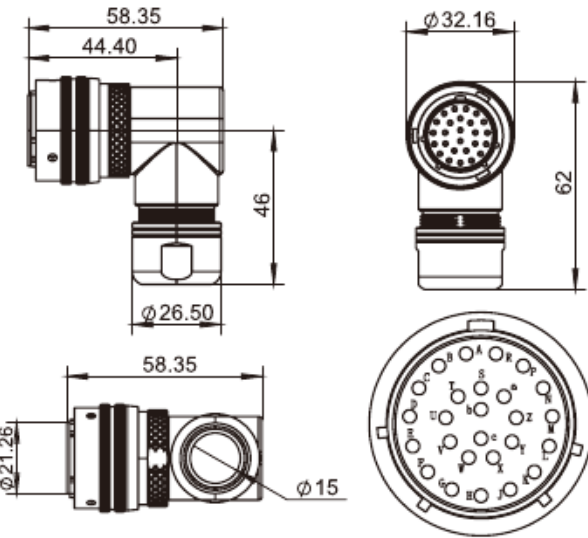

Profile、SUS Tube  
型材、钢管

Stents Module  
支架模组

Quick Changer  
快换

Grip Module  
夹具组件

Air Nipper  
气动剪刀

Vacuum Module  
真空组件

Accessory Components  
附件

# 90°接头

## 90°Connector

### 3108A22-08S

8芯90°接头(母头)

8 core 90° connector (female head)



货号(PN)	1.Y10710
型号(Model)	3108A22-08S

※ 重量 Weight:149.3g

※ 适配于 Suitable for:QCSM-08R

※ 原型号 Original model:3108A22-23S

### 3108A22-08P

8芯90°接头(公头)

8 core 90° connector (male head)



货号(PN)	1.Y10711
型号(Model)	3108A22-08P

※ 重量 Weight:119.2g

※ 适配于 Suitable for:QCSM-08G

※ 原型号 Original model:3108A22-23P

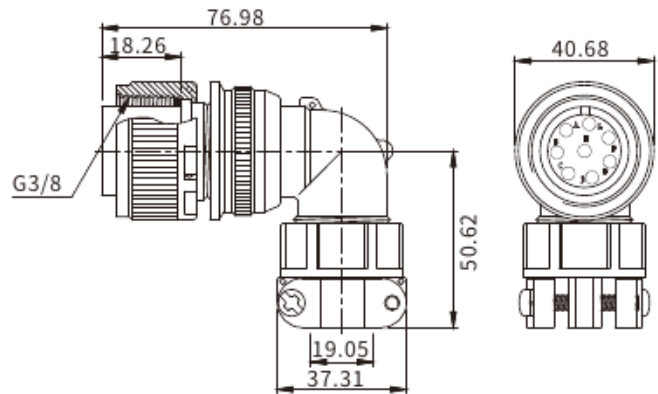
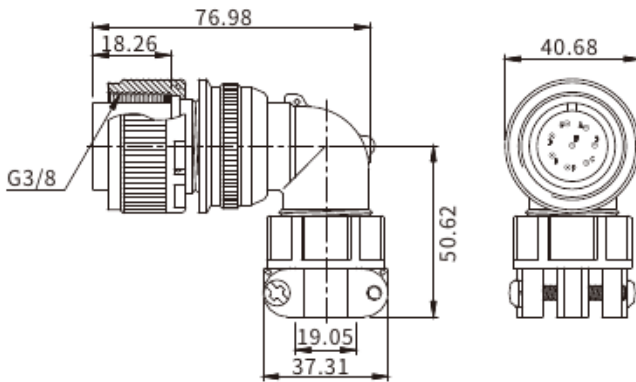

Profile- SUStube  
型材、钢管

Stents Module  
支架模组

Quick Changer  
快换

Grip Module  
夹具组件

Air Nipper  
气动剪刀

Vacuum Module  
真空组件

Accessory Components  
附件

# 接头

## Connector

Profile, SUS Tube  
型材、钢管

Stentis Module  
支架模组

Quick Changer  
快换

Grip Module  
夹具组件

Air Nipper  
气动剪刀

Vacuum Module  
真空组件

Accessory Components  
附件

### MS3116F14-19S

19芯直头接头(母头)

19 core straight connector (female head)



货号(PN)	1.Y11420	1.Y11420-Y
型号(Model)	MS3116F14-19S	MS3116F14-19S-Y

※ 重量 Weight: 36.8g

※ 适配于 Suitable for: QCSM-19R, QCSM-19R1

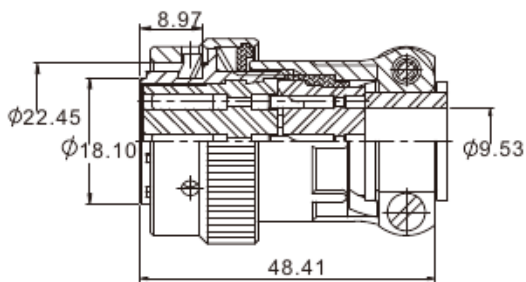

### MS3116F14-19P

19芯直头接头(公头)

19 core straight connector (male head)



货号(PN)	1.Y11419	1.Y11419-Y
型号(Model)	MS3116F14-19P	MS3116F14-19P-Y

※ 重量 Weight: 36.8g

※ 适配于 Suitable for: QCSM-19G

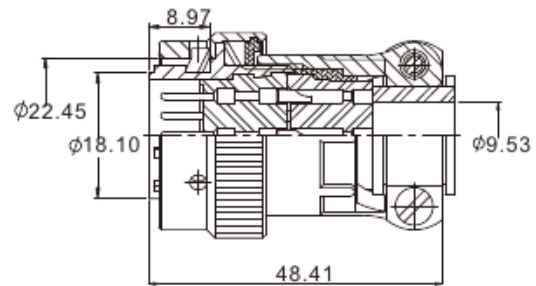
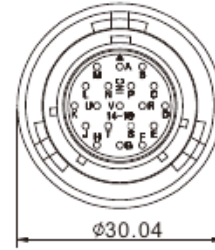

# 接头

## Connector

### MS3116F16-26S

26芯直头接头(母头)

26 core straight connector (female head)



货号(PN)	1.Y11867	1.Y11867-Y
型号(Model)	MS3116F16-26S	MS3116F16-26S-Y

※重量 Weight:44.8g

※适配于 Suitable for:QCSM-26R

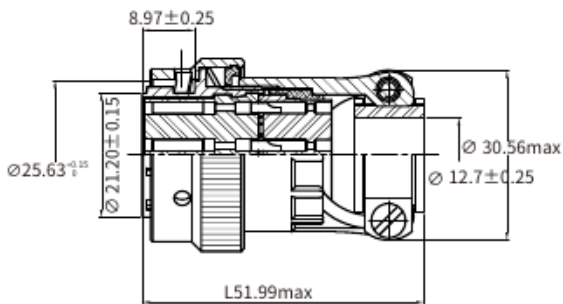
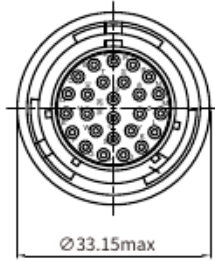

### MS3116F16-26P

26芯直头接头(公头)

26 core straight connector (male head)



货号(PN)	1.Y11369	1.Y11369-Y
型号(Model)	MS3116F16-26P	MS3116F16-26P-Y

※重量 Weight:44.8g

※适配于 Suitable for:QCSM-26G, QCSM-21/26G

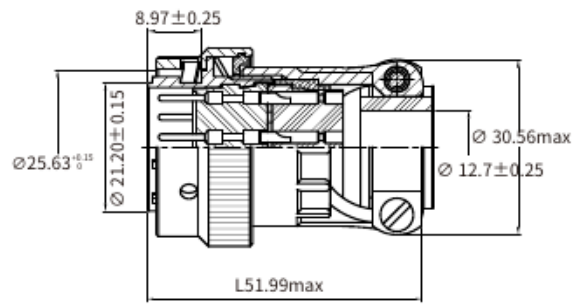
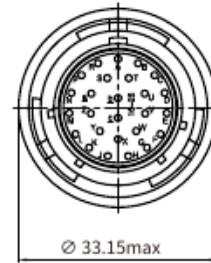

Profile- SUS Tube  
型材、钢管

Stents Module  
支架模组

Quick Changer  
快换

Grip Module  
夹具组件

Air Nipper  
气动剪刀

Vacuum Module  
真空组件

Accessory Components  
附件

# 接头

## Connector

### MS3116F22-36S

36芯直头接头(母头)  
36core straight connector (female head)



货号(PN)	1.Y13392
型号(Model)	MS3116F22-36S

\*重量 Weight: 91g  
\*适配于 Suitable for: QCSM-32R

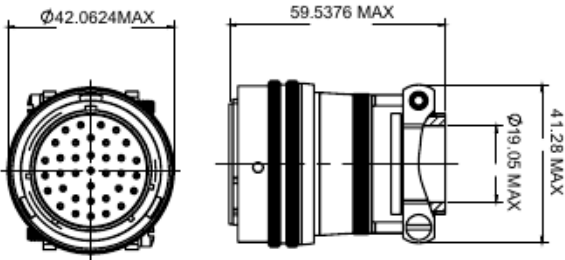

### MS3116F22-36P

36芯直头接头(公头)  
36 core straight connector (male head)



货号(PN)	1.Y13394
型号(Model)	MS3116F22-36P

\*重量 Weight: 85g  
\*适配于 Suitable for: QCSM-32G

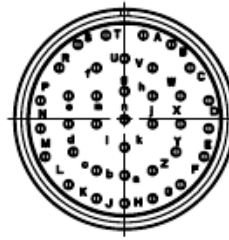
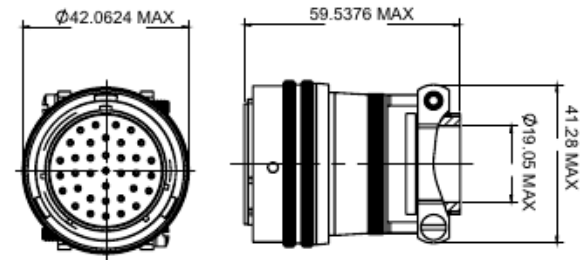

Profile, SUS Tube  
型材、钢管

Stentis Module  
支架模组

Quick Changer  
快换

Grip Module  
夹具组件

Air Nipper  
气动剪刀

Vacuum Module  
真空组件

Accessory Components  
附件

# 接头

## Connector

### MS3118F22-36S

36芯弯头接头(母头)

36 core bends connector (female head)



货号(PN)	1.Y13393
型号(Model)	MS3118F22-36S

※重量 Weight:112g

※适配于 Suitable for:QCSM-32R

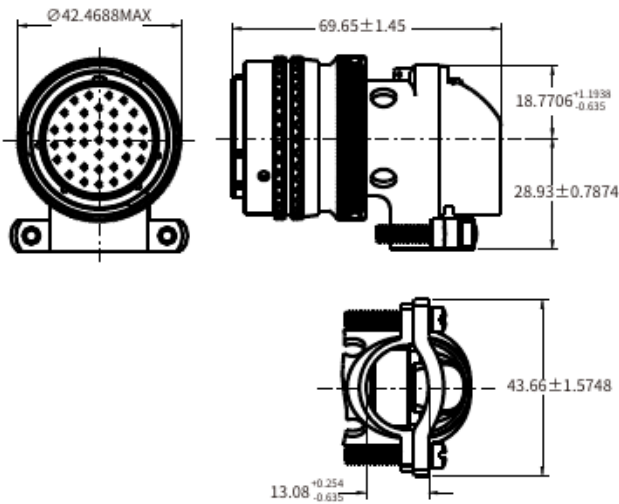

### MS3118F22-36P

36芯弯头接头(公头)

36 core bends connector (male head)



货号(PN)	1.Y13395
型号(Model)	MS3118F22-36P

※重量 Weight:108g

※适配于 Suitable for:QCSM-32G

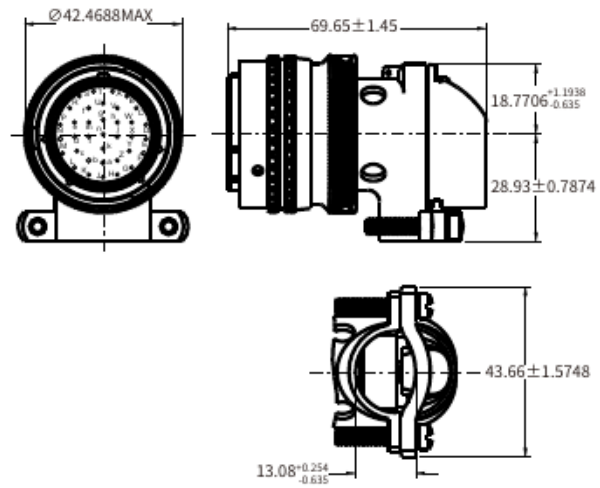

Profile- SUStube  
型材、钢管

Stents Module  
支架模组

Quick Changer  
快换

Grip Module  
夹具组件

Air Nipper  
气动剪刀

Vacuum Module  
真空组件

Accessory Components  
附件

## 机器人末端快换装置

A quick changer device at the end of a robot

- 适用于汽车行业点焊、大电流对接切换、大负载的搬运、负载可达500kg。
- Quick changer applied in the automotive industry for spot welding, high current docking switching, handling of large payload loads, payloads up to 500kgs.

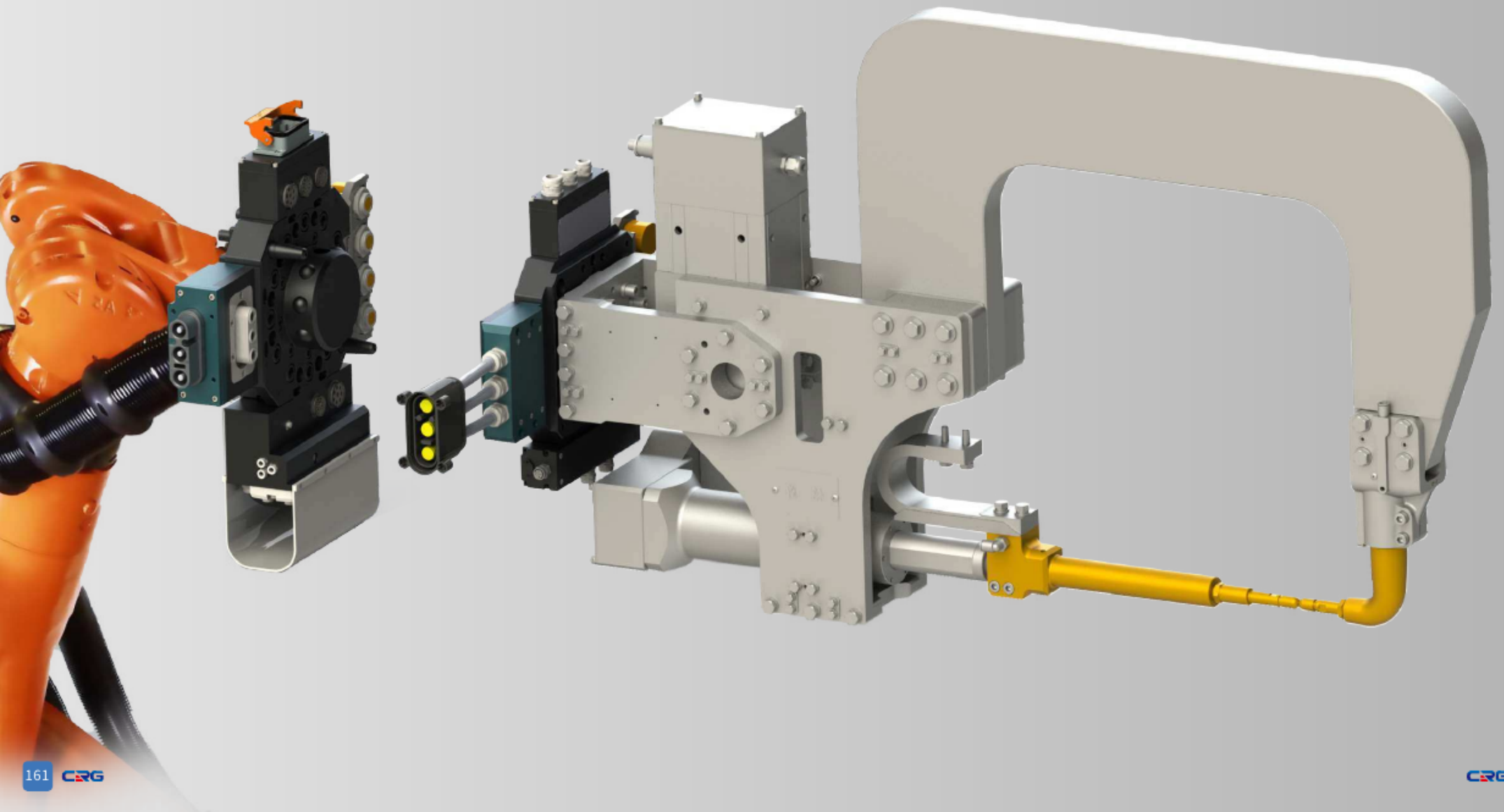

# 自动快换 Quick Changer

## QCA-S350



机器人侧  
Robot side



夹具侧  
Gripper side

货号(PN)	8.Y01009
型号(Model)	QCA-S350R-SP

货号(PN)	8.Y01010
型号(Model)	QCA-S350G

### 产品参数 Parameter

- 1.最大负载: 350 kg
- 2.锁紧力@80Psi(5.5Bar): 31000N
- 3.静态承载力矩 (X&Y): 2710Nm
- 4.静态承载力矩 (Z): 2260 Nm
- 5.位置重复精度 (X,Y&Z):  $\pm 0.015$  mm
- 6.机器人侧重量: 6.5 kg
- 7.夹具侧重量: 2.9kg
- 8.最大允许角偏移:  $\pm 1^\circ$

- 1.Max payload: 350kg
- 2.Locking force@80Psi (5.5Bar): 31000 N
- 3.Static Load torque (X&Y): 2710 Nm
- 4.Static Load torque (Z): 2260 Nm
- 5.Repeatability accuracy (X,Y&Z):  $\pm 0.015$  mm
- 6.Robot side's weight: 6.5 kg
- 7.Gripper side's weight: 2.9 kg
- 9.Maximum allowable angle deviation:  $\pm 1^\circ$

### 机器人侧 Robot side

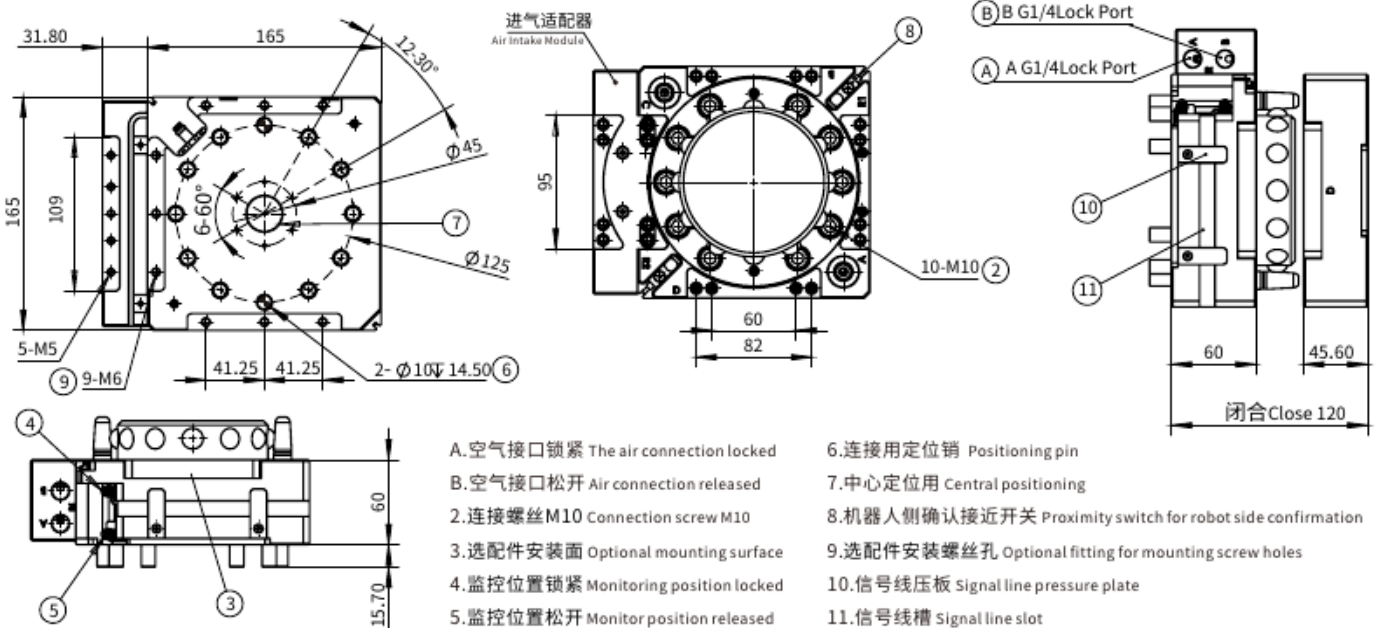

# 自动快换 Quick Changer

## 夹具侧 Gripper side

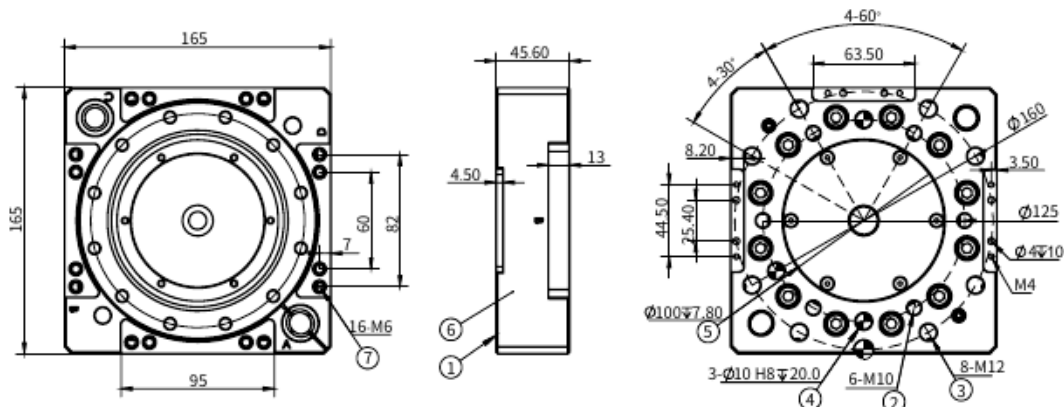

1. 夹具侧连接 Gripper side connection
2. 安装固定螺丝孔M10 Install fixed screw hole M10
3. 安装固定螺丝孔M12 Install fixed screw hole M12
4. 连接用定位销 Positioning pin
5. 中心定位用 Central positioning
6. 选配件安装面 Optional fitting mounting surface
7. 选配件安装固定螺丝 Optional fitting for mounting mounting screws

## 适用模块 Applicable Module

### 强电模块 Welding Power Module

产品名称 Product name	型号 Model	货号 PN
机器人强电模块 Robot side welding power module	QCSM-03R	7.Y02069
夹具侧强电模块 Gripper side welding power module	QCSM-03G	7.Y02070

### 气路模块 Pneumatic Module

产品名称 Product name	型号 Model	货号 PN
机器人侧气路模块 Robot side pneumatic module	QCAM-08G38R	7.Y02051
夹具侧气路模块 Gripper side pneumatic module	QCAM-08G38G	7.Y02052

### 水气模块 Water-Pneumatic Module

产品名称 Product name	型号 Model	货号 PN
机器人侧水气模块 Robot side water-pneumatic module	QCWM-02R1	7.Y02270
夹具侧水气模块 Gripper side water-pneumatic module	QCWM-02G1	7.Y02271
机器人侧水气模块 Robot side water-pneumatic module	QCWM-04R1	7.Y02071
夹具侧水气模块 Gripper side water-pneumatic module	QCWM-04G1	7.Y02072

### Profinet通讯总线模块 Profinet Communication Bus Module

产品名称 Product name	型号 Model	货号 PN
机器人侧Profinet通讯总线模块 Robot side Profinet Communication Bus Modules	QCBM-508R	7.Y02073
夹具侧Profinet通讯总线模块 Gripper side Profinet Communication Bus Modules	QCBM-508G	7.Y02074

### 伺服集合模块 Servo Assembly Module

产品名称 Product name	型号 Model	货号 PN
机器人侧伺服集合模块 Robot side Servo Assembly Module	QCSM-081926R-A	7.Y02090
夹具侧伺服集合模块 Gripper side Servo Assembly Module	QCSM-081926G-A	7.Y02091
机器人侧伺服集合模块 Robot side Servo Assembly Module	QCSM-081926R-Y	7.Y03864
夹具侧伺服集合模块 Gripper side Servo Assembly Module	QCSM-081926G-Y	7.Y03865
机器人侧伺服集合模块 Robot side Servo Assembly Module	QCSM-081926R-K	7.Y03866
夹具侧伺服集合模块 Gripper side Servo Assembly Module	QCSM-081926G-K	7.Y03867
机器人侧伺服集合模块 Robot side Servo Assembly Module	QCSM-081926R-F	7.Y03868
夹具侧伺服集合模块 Gripper side Servo Assembly Module	QCSM-081926G-F	7.Y03869

Profile- SUS Tube  
型材、钢管

Stents Module  
支架模组

Quick Changer  
快换

Gripper Module  
夹具组件

Air Nipper  
气动剪刀

Vacuum Module  
真空组件

Accessory Components  
附件

# 自动快换 Quick Changer

## QCA-S500

Profile、SUS Tube  
型材、钢管

Stentis Module  
支架模组

Quick Changer  
快换

Grip Module  
夹具组件

Air Gripper  
气动夹刀

Vacuum Module  
真空组件

Accessory Components  
附件



机器人侧  
Robot side

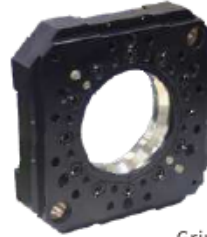

夹具侧  
Gripper side

货号(PN)	8.Y01015
型号(Model)	QCA-S500R-SP

货号(PN)	8.Y01016
型号(Model)	QCA-S500G

### 产品参数

#### Parameter

- 1.最大负载: 500 kg
- 2.锁紧力@80Psi (5.5Bar): 38000N
- 3.静态承载力矩 (X&Y): 3290Nm
- 4.静态承载力矩 (Z): 3160 Nm
- 5.位置重复精度 (X,Y&Z):  $\pm 0.015$  mm
- 6.机器人侧重量: 15.9 kg
- 7.夹具侧重量: 7.5kg
- 8.最大允许角偏移:  $\pm 1^\circ$

- 1.Max payload: 500kg
- 2.Locking force@80Psi (5.5Bar): 38000 N
- 3.Static Load torque (X&Y): 3290 Nm
- 4.Static Load torque (Z): 3160 Nm
- 5.Repeatability accuracy (X,Y&Z):  $\pm 0.015$  mm
- 6.Robot side's weight: 15.9 kg
- 7.Gripper side's weight: 7.5 kg
- 8.Maximum allowable angle deviation:  $\pm 1^\circ$

### 机器人侧

#### Robot side

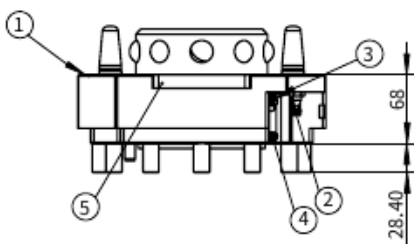
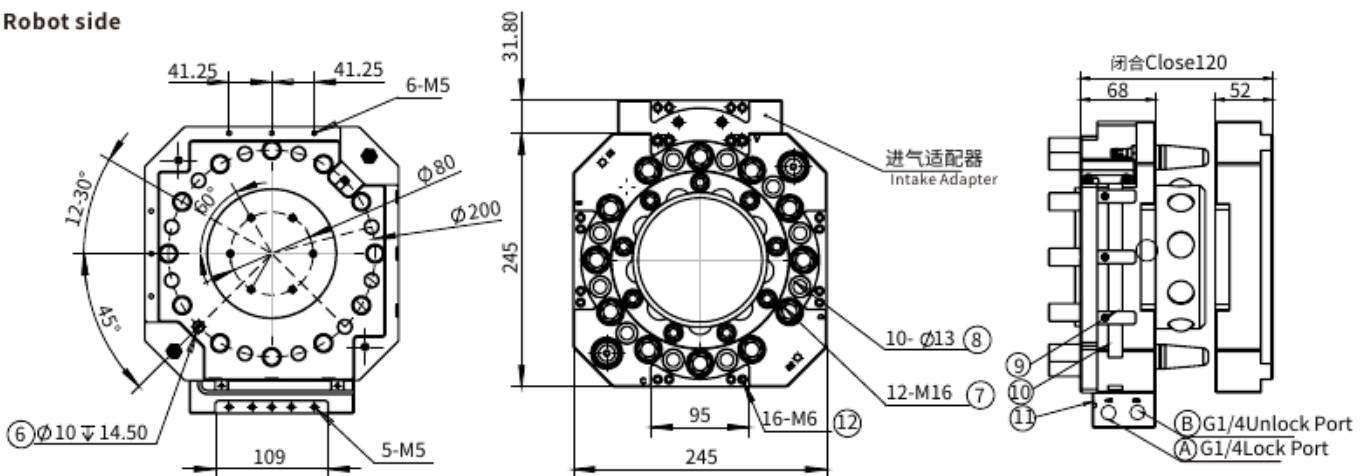

A. 空气接口锁紧 The air connection locked

B. 空气接口松开 Air connection released

1. 机器人侧连接 Robot side connection

2. 机器人侧确认接近开关 Robot side confirm proximity switch

3. 监控位置松开 Monitor position released

4. 监控位置锁紧 Monitoring position locked

5. 选配件安装螺丝孔 Optional fitting for mounting screw holes

6. 连接用固定销 Positioning pin

7. 安装螺丝M16-12 Connection screw M16-12

8. 螺丝安装用通孔 Through hole for screw installation

9. 信号线压板 Signal line pressure plate

10. 信号线槽 Signal line slot

11. 进气适配器 Intake Adapter

12. 选配件安装面 Optional mounting surface

# 自动快换 Quick Changer

## 夹具侧 Gripper side

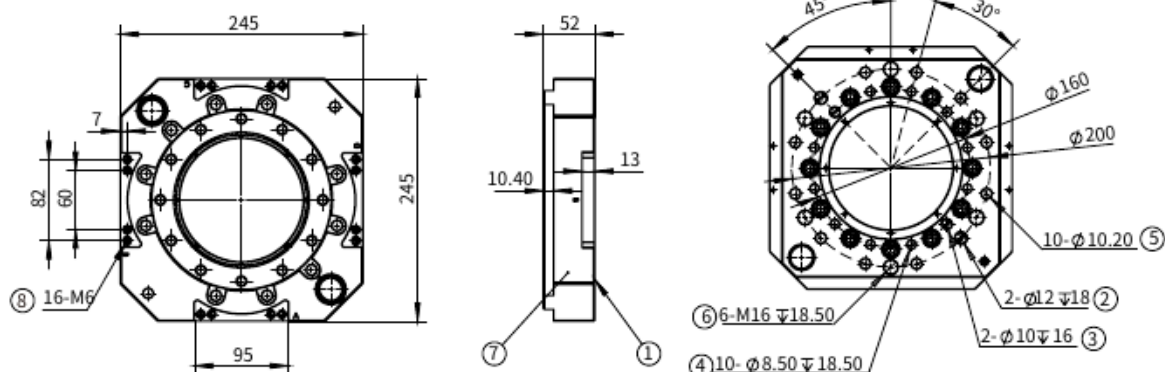

1. 夹具侧连接 Gripper connection
2. 安装用固定销直径12 Mounting pin diameter 12
3. 安装用固定销直径10 Mounting pin diameter 10
4. 安装螺丝牙孔 Install screw hole

5. M10螺丝安装用通孔 M10 Through hole for screw installation
6. 工具侧连接 Gripper side connection
7. 选配件安装面 Tool side mount
8. 选配件安装固定螺栓 Option mounting fixing bolts

## 适用模块 Applicable Module

### 强电模块 Welding Power Module

产品名称 Product name	型号 Model	货号 PN
机器人强电模块 Robot side welding power module	QCSM-03R	7.Y02069
夹具侧强电模块 Gripper side welding power module	QCSM-03G	7.Y02070

### 气路模块 Pneumatic Module

产品名称 Product name	型号 Model	货号 PN
机器人侧气路模块 Robot side pneumatic module	QCAM-08G38R	7.Y02051
夹具侧气路模块 Gripper side pneumatic module	QCAM-08G38G	7.Y02052

### 水气模块 Water-Pneumatic Module

产品名称 Product name	型号 Model	货号 PN
机器人侧水气模块 Robot side water-pneumatic module	QCWM-02R1	7.Y02270
夹具侧水气模块 Gripper side water-pneumatic module	QCWM-02G1	7.Y02271
机器人侧水气模块 Robot side water-pneumatic module	QCWM-04R1	7.Y02071
夹具侧水气模块 Gripper side water-pneumatic module	QCWM-04G1	7.Y02072

### Profinet通讯总线模块 Profinet Communication Bus Module

产品名称 Product name	型号 Model	货号 PN
机器人侧Profinet通讯总线模块 Robot side Profinet Communication Bus Modules	QCBM-508R	7.Y02073
夹具侧Profinet通讯总线模块 Gripper side Profinet Communication Bus Modules	QCBM-508G	7.Y02074

### 伺服集合模块 Servo Assembly Module

产品名称 Product name	型号 Model	货号 PN
机器人侧伺服集合模块 Robot side Servo Assembly Module	QCSM-081926R-A	7.Y02090
夹具侧伺服集合模块 Gripper side Servo Assembly Module	QCSM-081926G-A	7.Y02091
机器人侧伺服集合模块 Robot side Servo Assembly Module	QCSM-081926R-Y	7.Y03864
夹具侧伺服集合模块 Gripper side Servo Assembly Module	QCSM-081926G-Y	7.Y03865
机器人侧伺服集合模块 Robot side Servo Assembly Module	QCSM-081926R-K	7.Y03866
夹具侧伺服集合模块 Gripper side Servo Assembly Module	QCSM-081926G-K	7.Y03867
机器人侧伺服集合模块 Robot side Servo Assembly Module	QCSM-081926R-F	7.Y03868
夹具侧伺服集合模块 Gripper side Servo Assembly Module	QCSM-081926G-F	7.Y03869

Profile- SUS Tube  
型材、钢管

Stents Module  
支架模组

Quick Changer  
快换

Gripper Module  
夹具组件

Air Nipper  
气动剪刀

Vacuum Module  
真空组件

Accessory Components  
附件

## 选配模块 Optional Modules

Profile、SUS Tube  
型材、钢管

Stentis Module  
支架模组

Quick Changer  
快换

Grip Module  
夹具组件

Air Nipper  
气动剪刀

Vacuum Module  
真空组件

Accessory Components  
附件

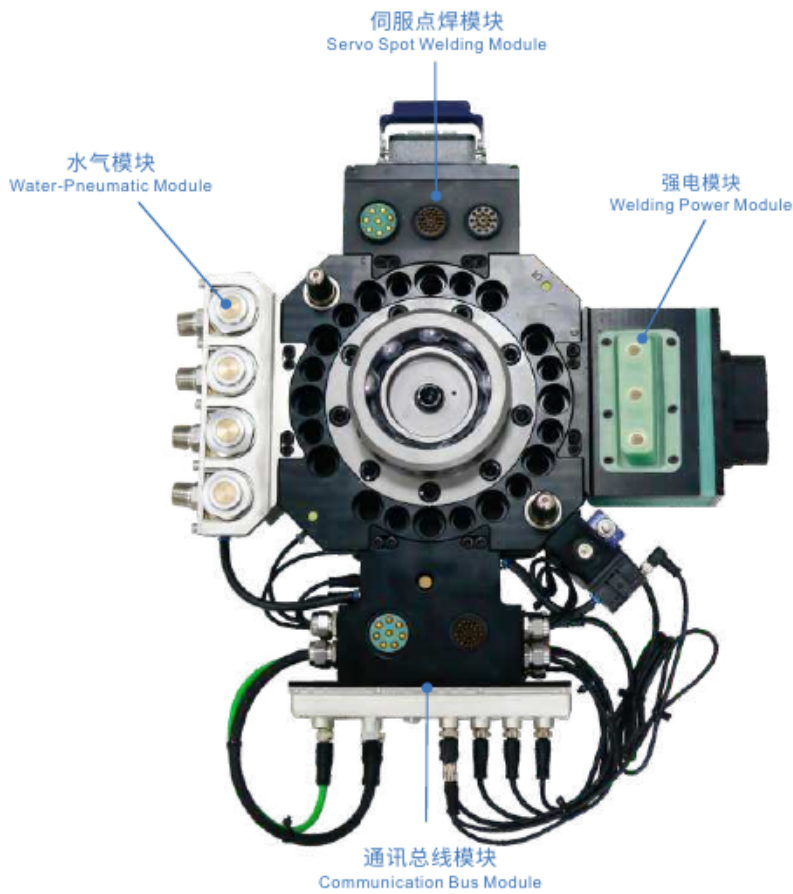
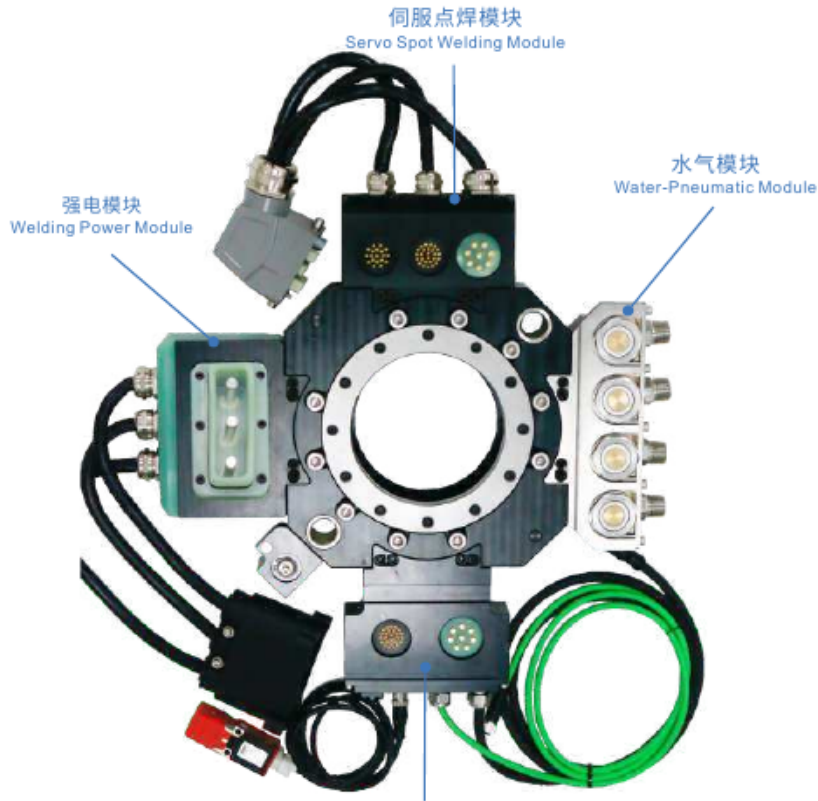

# 水气模块

## Water-Pneumatic Module

### QCWM-02R1

机器人侧模块  
Robot side module

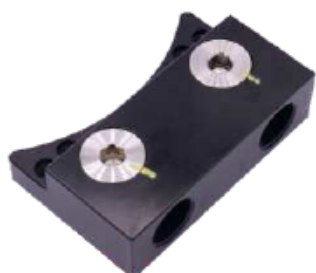

货号(PN)	7.Y02270
型号(Model)	QCWM-02R1

※ 重量 Weight: 343g  
※ 适配于 Suitable for: QCA-S350, QCA-S500

### QCWM-02G1

夹具侧模块  
Gripper side module



货号(PN)	7.Y02271
型号(Model)	QCWM-02G1

※ 重量 Weight: 337g

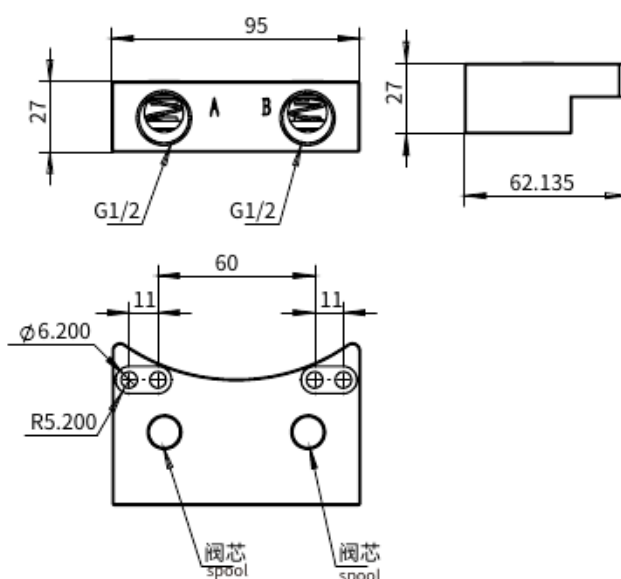
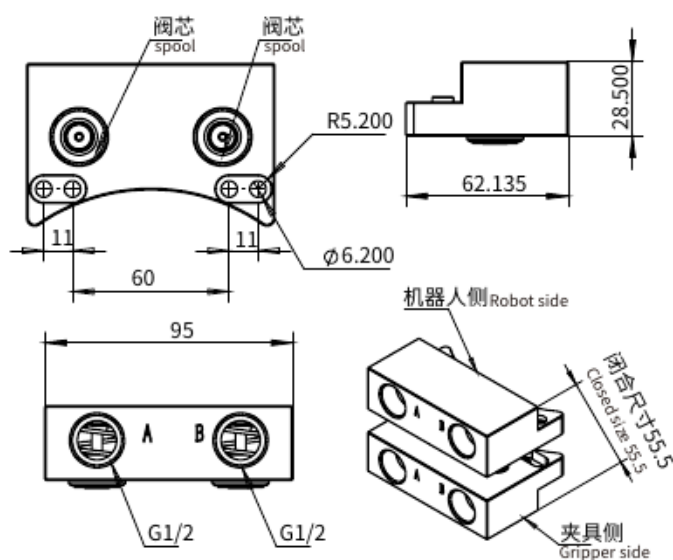

主体材料 Body material	阀芯材料 Spool material	类型 Type	接口数量 Interface number	接口尺寸 Interface size
铝硬质氧化 Aluminum hard oxide	不锈钢 Stainless steel	自封气 Self-sealing gas	2路 2-way	G1/2

型材、钢管  
Profile, SUStube

支架模组  
Stents Module

快换  
Quick Changer

夹具组件  
Grip Module

气动剪刀  
Air Nipper

真空组件  
Vacuum Module

附件  
Accessory Components

# 水气模块

## Water-Pneumatic Module

### QCWM-04R1

机器人侧模块  
Robot side module



货号(PN)	7.Y02071
型号(Model)	QCWM-04R1

※ 重量Weight: 3.25Kg  
※ 适配于 Suitable for: QCA-S350, QCA-S500

### QCWM-04G1

夹具侧模块  
Gripper side module



货号(PN)	7.Y02072
型号(Model)	QCWM-04G1

※ 重量Weight: 2.96Kg

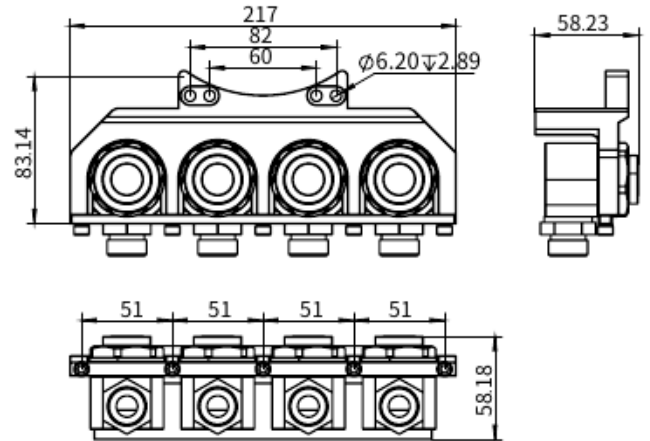
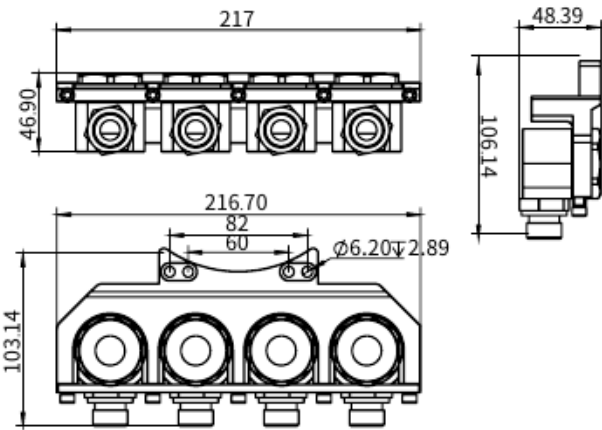

Profile、SUS Tube  
型材、钢管

Stents Module  
支架模组

Quick Changer  
快换

Grip Module  
夹具组件

Air Nipper  
气动剪刀

Vacuum Module  
真空组件

Accessory Components  
附件

# 强电模块

## Welding Power Module

### QCSM-03R

机器人侧模块  
Robot side module



货号(PN)	7.Y02069
型号(Model)	QCSM-03R

- ※ 电流 Current: 150A
- ※ 重量 Weight: 2.6Kg
- ※ 适配于 Suitable for: QCA-S350, QCA-S500

### QCSM-03G

夹具侧模块  
Gripper side module

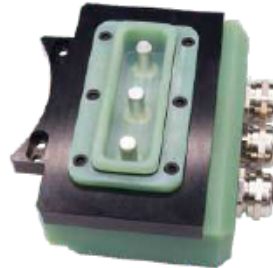

货号(PN)	7.Y02070
型号(Model)	QCSM-03G

- ※ 电流 Current: 150A
- ※ 重量 Weight: 1.85Kg

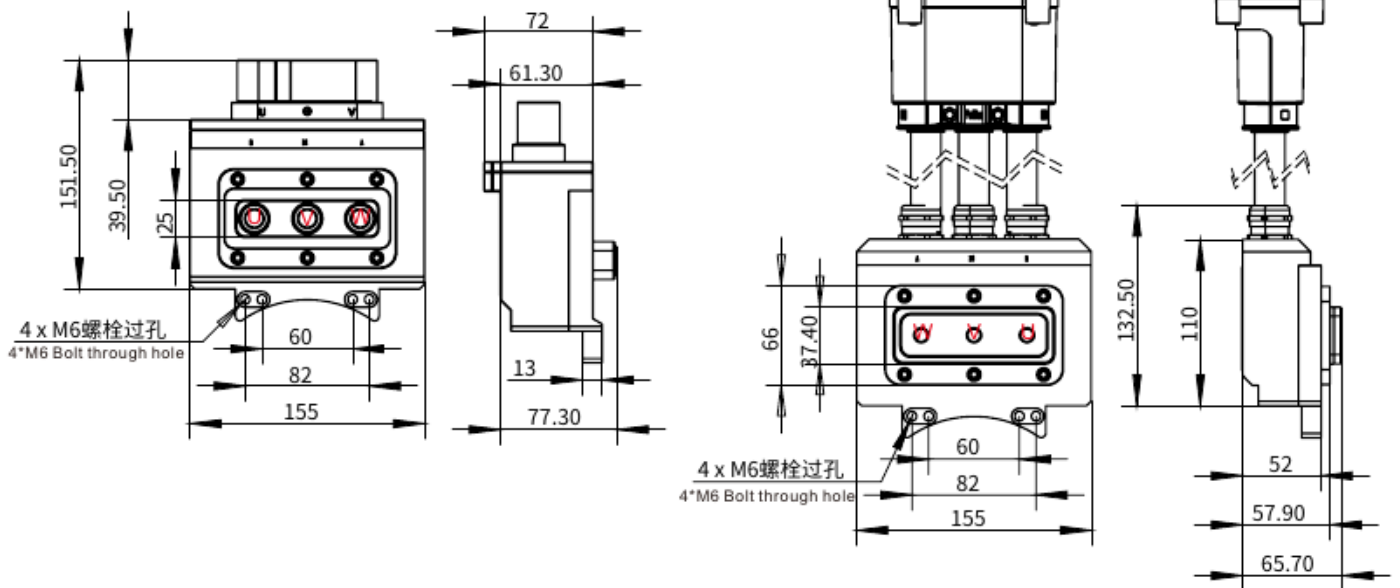

## 接线图/Wiring Diagram

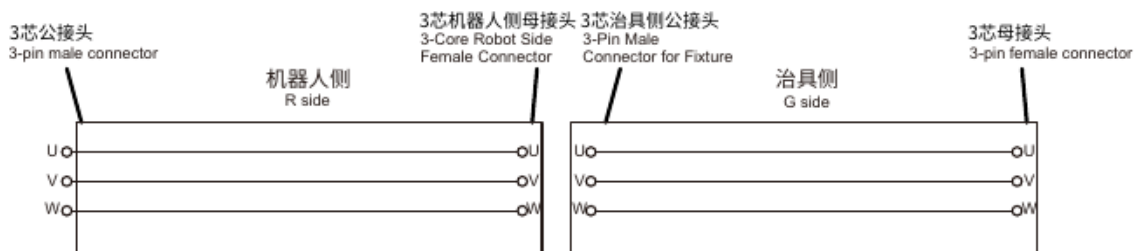

Profile- SUS Tube  
型材、钢管

Stents Module  
支架模组

Quick Changer  
快换

Grip Module  
夹具组件

Air Nipper  
气动剪刀

Vacuum Module  
真空组件

Accessory Components  
附件

# 气路模块

## Pneumatic Module

### QCAM-08G38R

机器人侧模块  
Robot side module



货号(PN)	7.Y02051
型号(Model)	QCAM-08G38R

\* 重量Weight: 1.25Kg  
\* 适配于 Suitable for: QCA-S350, QCA-S500

### QCAM-08G38G

夹具侧模块  
Gripper side module



货号(PN)	7.Y02052
型号(Model)	QCAM-08G38G

\* 重量Weight: 1.1Kg

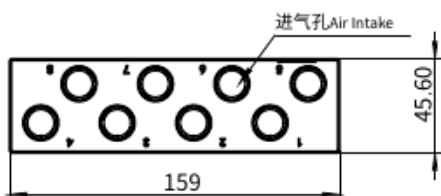
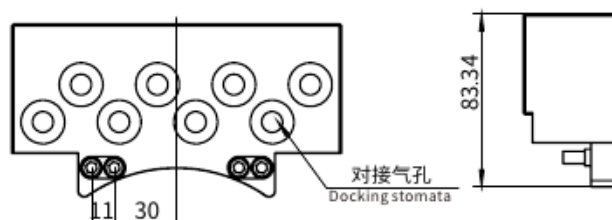
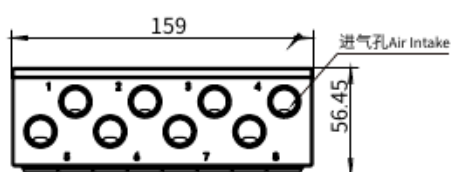
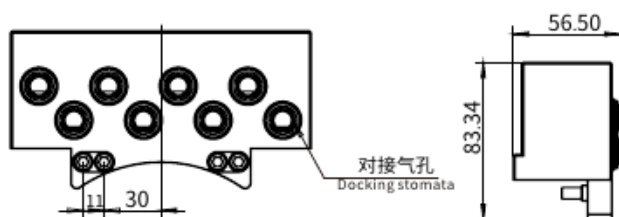

# Profinet通讯总线模块

## Profinet Communication Bus Module

### QCBM-508R

机器人侧模块  
Robot side module



货号(PN)	7.Y02073
型号(Model)	QCBM-508R

※ 总线通讯, 内置集成电磁阀控制, 压力检测, 安全开关, 工具识别, 安全停靠, 安全接地, 传感器接口。可根据不同通讯协议类型配置接口。

※ Bus communication, built-in integrated solenoid valve control, pressure detection, safety switches, tool identification, safety stops, safety grounding, sensor interfaces. Safety stop, safety grounding, sensor interface. Interfaces can be configured according to different communication protocol types.

※ 适配于 Suitable for: QCA-S350, QCA-S500

### QCBM-508G

夹具侧模块  
Gripper side module



货号(PN)	7.Y02074
型号(Model)	QCBM-508G

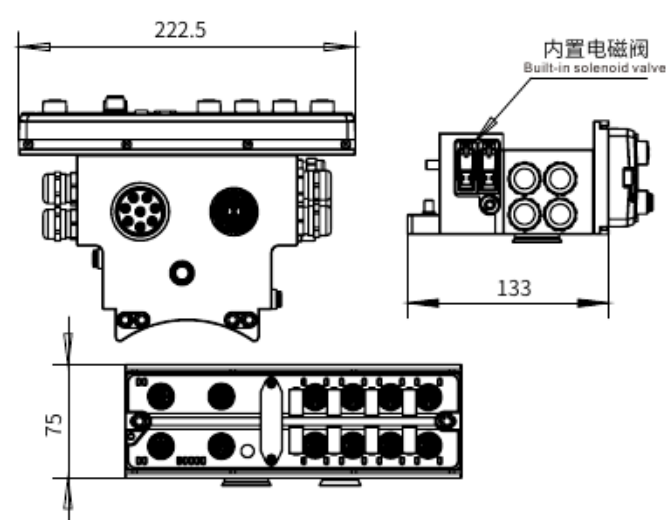

接地组件R侧  
Grounding assembly R side

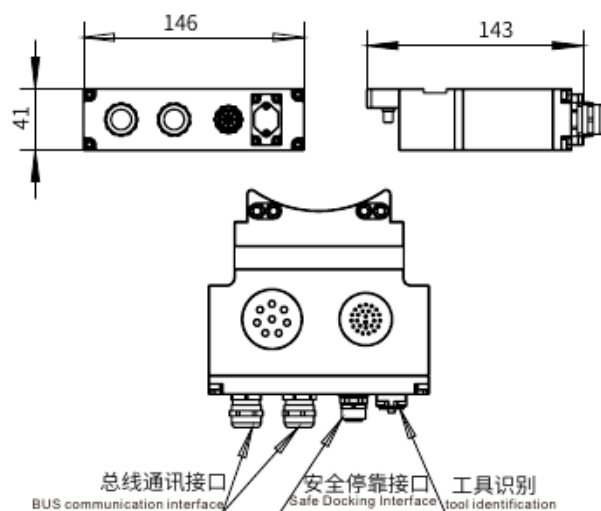
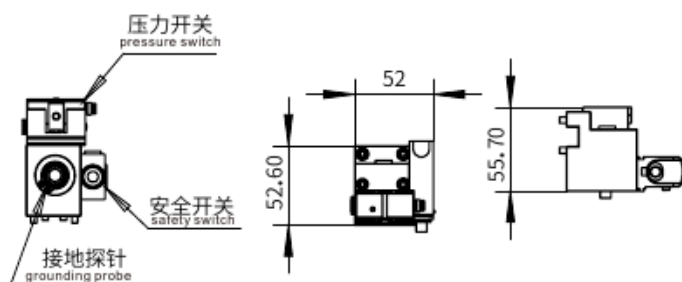

接地组件G侧  
Grounding assembly G side

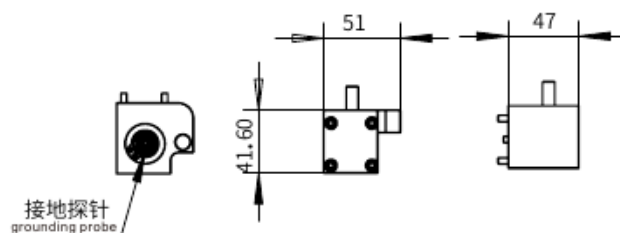

Profile- SUS Tube  
型材、钢管

Stents Module  
支架模组

Quick Changer  
快换

Grip Module  
夹具组件

Air Nipper  
气动剪刀

Vacuum Module  
真空组件

Accessory Components  
附件

# 伺服集合模块

## Servo Assembly Module

### QCSM-081926R

机器人侧模块  
Robot side module



货号(PN)	7.Y02090
型号(Model)	QCSM-081926R-A

- ※应用: 焊钳驱动部伺服电机的电源供电、编码器、信号反馈  
20A\*4芯电流传输, 2芯抱闸 3A\*8芯编码器信号传输 3A\*26芯信号传输
- ※可作为普通模块使用: 供电+信号 20A\*8芯电流传输 3A\*25芯信号传输
- ※适配于: QCA-S350、QCA-S500
- ※适配于: ABB机器人

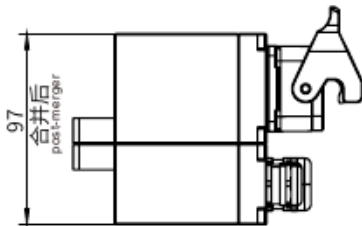
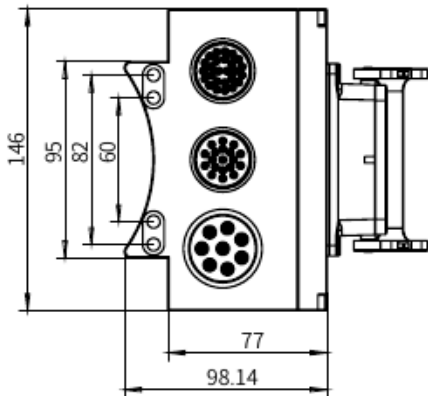
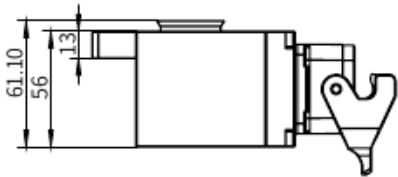

### QCSM-081926G

夹具侧模块  
Gripper side module



货号(PN)	7.Y02091
型号(Model)	QCSM-081926G-A

- ※ Application: Power supply, encoder, signal feedback for servo motor of welding clamp drive unit.  
20A\*4 core current transmission, 2 core holding brake  
3A\*8 core encoder signal transmission 3A\*26 core signal transmission
- ※ Can be used as a general module: power supply + signal 20A \* 8-cell current transmission  
3A \* 25-cell signal transmission
- ※ Adaptable to: QCAS350, QCAS500.
- ※ Adaptation to: ABB robots

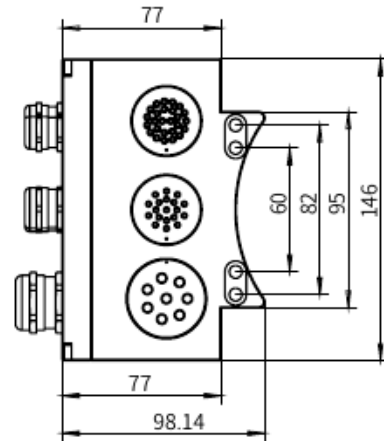
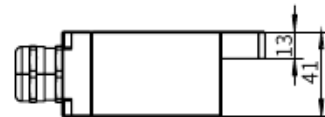

Profile、SUS Tube  
型材、钢管

Stents Module  
支架模组

Quick Changer  
快换

Grip Module  
夹具组件

Air Nipper  
气动剪刀

Vacuum Module  
真空组件

Accessory Components  
附件

# 伺服集合模块

## Servo Assembly Module

机器人侧模块

Robot side module



货号 (PN)	7.Y03864
型号 (Model)	QCSM-081926R-Y

- ※应用: 焊钳驱动部伺服电机的电源供电、编码器、信号反馈
- 20A\*4芯电流传输, 2芯抱闸 3A\*8芯编码器信号传输 3A\*26芯信号传输
- ※可作为普通模块使用: 供电+信号 20A\*7芯电流传输 3A\*31芯信号传输
- ※ 适配于: QCAS-350, QCA-S500
- ※ 适配于: 安川机器人



货号 (PN)	7.Y03866
型号 (Model)	QCSM-081926R-K

- ※应用: 焊钳驱动部伺服电机的电源供电、编码器、信号反馈
- 20A\*4芯电流传输, 2芯抱闸 3A\*8芯编码器信号传输 3A\*26芯信号传输
- ※可作为普通模块使用: 供电+信号 20A\*3芯电流传输 3A\*29芯信号传输
- ※ 适配于: QCAS-350, QCA-S500
- ※ 适配于: 库卡机器人



货号 (PN)	7.Y03868
型号 (Model)	QCSM-081926R-F

- ※应用: 焊钳驱动部伺服电机的电源供电、编码器、信号反馈
- 20A\*4芯电流传输, 2芯抱闸 3A\*8芯编码器信号传输 3A\*26芯信号传输
- ※可作为普通模块使用: 供电+信号 20A\*5芯电流传输 3A\*41芯信号传输
- ※ 适配于: QCA-S350, QCA-S500
- ※ 适配于: 发那科机器人

夹具侧模块

Gripper side module



货号 (PN)	7.Y03865
型号 (Model)	QCSM-081926G-Y

- ※ Application: Power supply, encoder, signal feedback for servo motor of welding clamp drive unit.
- 20A\*4 core current transmission, 2 core holding brake
- 3A\*8 core encoder signal transmission 3A\*26 core signal transmission
- ※ Can be used as a general module: power supply + signal 20A\*7-cell current transmission
- 3A\*31-core signal transmission
- ※ Adaptable to: QCAS350, QCAS500.
- ※ Adaptation to: YASKAWA robots



货号 (PN)	7.Y03867
型号 (Model)	QCSM-081926G-K

- ※ Application: Power supply, encoder, signal feedback for servo motor of welding clamp drive unit.
- 20A\*4 core current transmission, 2 core holding brake
- 3A\*8 core encoder signal transmission 3A\*26 core signal transmission
- ※ Can be used as a general module: power supply + signal 20A\*3-cell current transmission
- 3A\*29-core signal transmission
- ※ Adaptable to: QCAS350, QCAS500.
- ※ Adaptation to: KUKA robots



货号 (PN)	7.Y03869
型号 (Model)	QCSM-081926G-F

- ※ Application: Power supply, encoder, signal feedback for servo motor of welding clamp drive unit.
- 20A\*4 core current transmission, 2 core holding brake
- 3A\*8 core encoder signal transmission 3A\*26 core signal transmission
- ※ Can be used as a general module: power supply + signal 20A\*5-cell current transmission
- 3A\*41-core signal transmission
- ※ Adaptable to: QCAS350, QCAS500.
- ※ Adaptation to: FANUC robots

Profile- SUS Tube  
型材、钢管

Stents Module  
支架模组

Quick Changer  
快换

Grip Module  
夹具组件

Air Nipper  
气动剪刀

Vacuum Module  
真空组件

Accessory Components  
附件

# 圆形手动快换

## Round Manual Quick Changer

Profile, SUS Tube  
型材、钢管

Stents Module  
支架模组

Quick Changer  
快换

Grip Module  
夹具组件

Air Nipper  
气动剪刀

Vacuum Module  
真空组件

Accessory Components  
附件

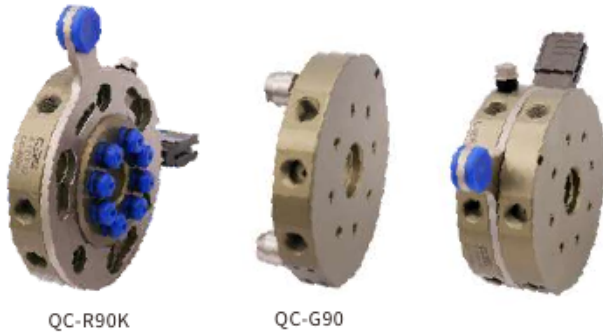

QC-R90K

QC-G90

- 机械手上的EOAT易于更换
  - 同样适用于真空端。
  - 避免了在气动和电气连接时的错误。
  - 4, 8, 10或12个气动连接。
  - 两部分(机械手侧和治具侧) 分开提供。
- Easy replacement of the EOAT on the robot.
  - Suitable also with vacuum ports.
  - Avoids mistakes in pneumatic and electrical connections.
  - 4, 8, 10 or 12 pneumatic connections.
  - The two parts (robot side and gripper side) are supplied separately.

型号 (Model)	QC50	QC90	QC150	QC160	QC200
介质 Medium	已过滤压缩空气 Filtered compressed air				
压力范围 Pressure range	5~6 bar				
温度范围 Temperature range	5 ~ 60 °C				
机械手侧的快速转换模块 Robot side quick changer	QC-R50K	QC-R90K	QC-R150K	QC-R160K	QC-R200K
机械手侧的快速转换模块重量 Robot side quick changer weight	103 g	318 g	1159 g	1200 g	2640 g
治具侧的快速转换模块 Gripper side quick changer	QC-G50	QC-G90	QC-G150	QC-G160	QC-G200
治具侧的快速转换模块重量 Gripper side quick changer weight	65 g	227 g	837g	900 g	1890 g
垂直拉力 F	150N	400N	1000N	1000N	2000N
旋转扭矩 Mt	20Nm	100Nm	250Nm	250Nm	600Nm
翻转扭矩 Mb	10Nm	60Nm	150Nm	150Nm	300Nm
建议负载 Recommended payload	5kg	15kg	35kg	35kg	75kg
颜色 Colour	古铜色 Brass	古铜色 Brass	黑色 Black	古铜色 Brass	黑色 Black

### 安装使用示例

#### Installation and use example



附锁安装示例  
Example of Install with lock



# 圆形手动快换

## Round Manual Quick Changer

### 配件/Accessories

#### 电气连接组件

- D-SUB 9 针连接器 I/O 快速转换模块.
- 两部分分开提供:  
QCSM-9R2 机械手侧信号模块  
QCSM-9G2 治具侧信号模块  
R9-1000 45度金属母接头  
G9-1000 45度金属公接头

#### Electrical connection module

- I/O quick change by D-SUB 9 pins connector.
- The two parts are supplied separately.  
QCSM-9R2 robot side signal module.  
QCSM-9G2 gripper side signal module.  
R9-1000 45 degree metal female fitting.  
G9-1000 45 degree metal male fitting.

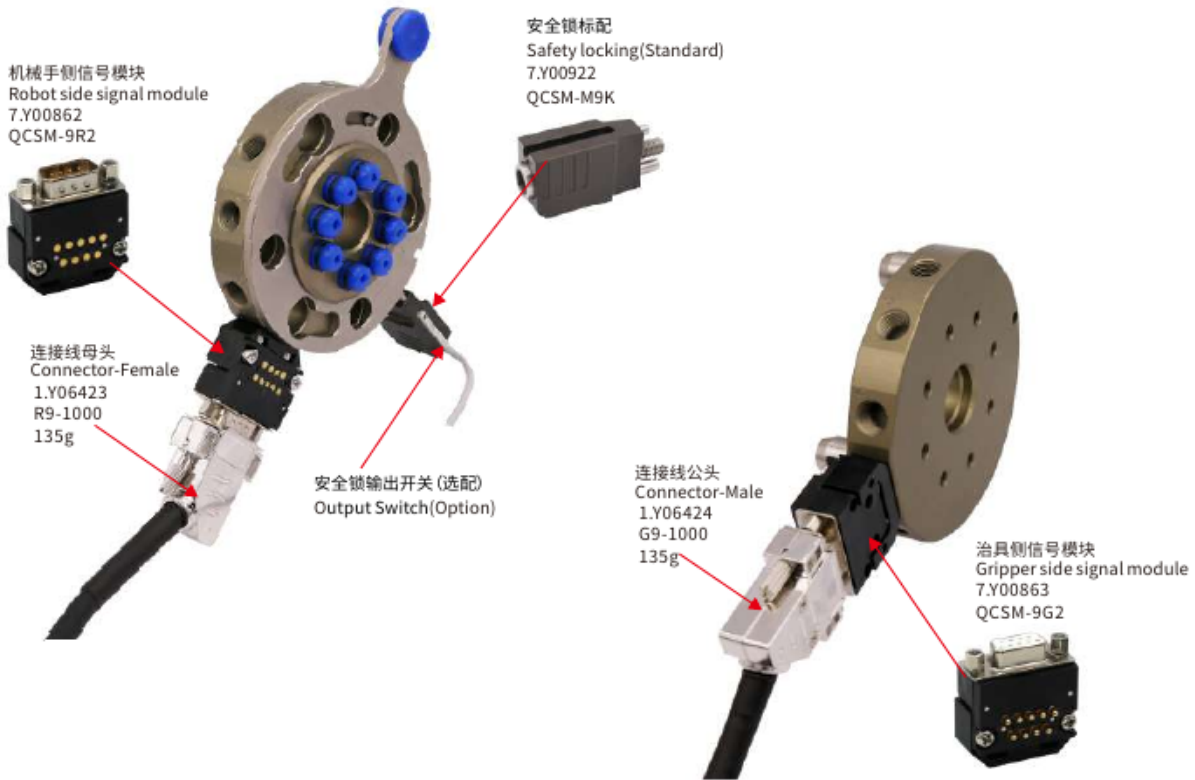

### 信号线截面示意图/Signal Wire Cross-sectional Sketch Map

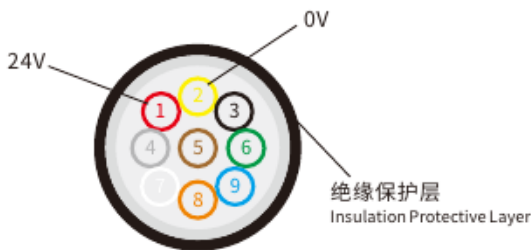

安全锁输出开关  
Output Switch

Profile- SUS Tube  
型材、钢管

Stents Module  
支架模组

Quick Changer  
快换

Grip Module  
夹具组件

Air Nipper  
气动剪刀

Vacuum Module  
真空组件

Accessory Components  
附件

# 圆形手动快换

## Round Manual Quick Changer

### QC-50



机器人侧  
Robot side



夹具侧  
Gripper side

货号 (PN)	8.Y00402
型号 (Model)	QC-R50K

货号 (PN)	8.Y00055
型号 (Model)	QC-G50

### 产品参数

#### Parameter

- |                             |  |
|-----------------------------|--|
| 1. 建议额定载荷: 5 kg             | 1. Recommended rated load: 5kg                   |
| 2. 介质: 已过滤压缩空气              | 2. Medium: Filtered compressed air               |
| 3. 压力范围: 5-6bar             | 3. Pressure Range: 5-6bar                        |
| 4. 温度范围: 5-60°C             | 4. Temperature Range: 5-60°C                     |
| 5. 垂直拉力: 150N               | 5. Vertical Pulling Force F: 150N                |
| 6. 旋转扭矩: 20Nm               | 6. Rotating Torque Mt: 20Nm                      |
| 7. 翻转扭矩: 10Nm               | 7. Reversal Torque Mb: 10Nm                      |
| 8. 机器人侧重量: 103g             | 8. Robot side weight: 103g                       |
| 9. 治具侧重量: 65g               | 9. Gripper side weight: 65g                      |
| 10. 位置重复精度 (X,Y&Z): ±0.05mm | 10. Repeatability accuracy (X, Y&Z): ±0.05mm     |
| 11. 颜色: 古铜色                 | 11. Colour: Brass                                |
| 12. 直通型气孔尺寸 (数量): (4) M5    | 12. Size of straight air hole (quantity): (4) M5 |

### 模块类型

#### Module Type

产品图 Product	产品名称 Product name	型号 Model	货号 PN	I/O连接类型 I/O connection type	工作电流 Working current	连接线 Cable	重量 Weight
	机械手侧信号模块 Robot side signal module	QC5M-9R1	7.Y00823	9针D-SUB	MAX 3A	R9-1000 (1.Y06423)	31g
	治具侧信号模块 Gripper side signal module	QC5M-9G1	7.Y00824	9针D-SUB	MAX 3A	G9-1000 (1.Y06424)	31g

\*R9-1000, G9-1000选配, 连接线长为1米  
\*R9-1000, G9-1000 option, the cable's length is 1 meter

Profile, SUS Tube  
型材、钢管

Stents Module  
支架模组

Quick Changer  
快换

Grip Module  
夹具组件

Air Nipper  
气动剪刀

Vacuum Module  
真空组件

Accessory Components  
附件

# 圆形手动快换

## Round Manual Quick Changer

### 机器人侧

Robot side

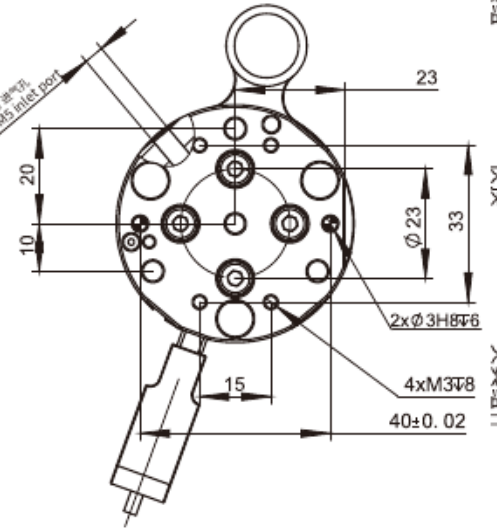
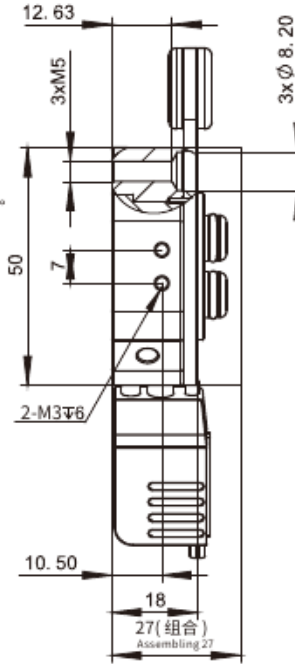
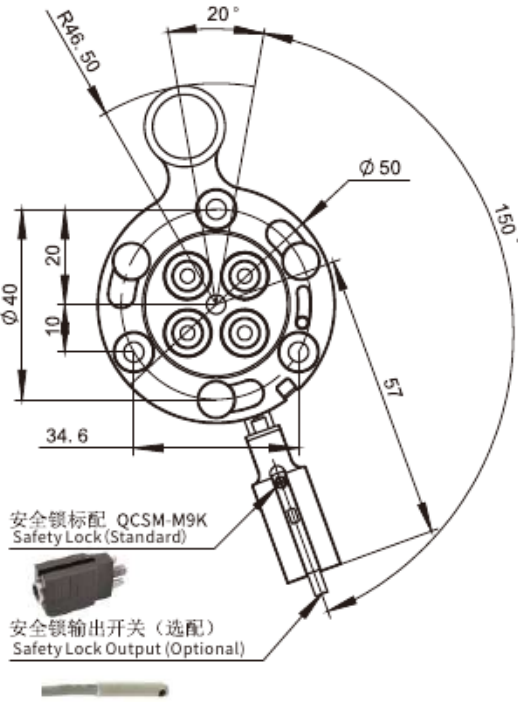

### 夹具侧

Gripper side

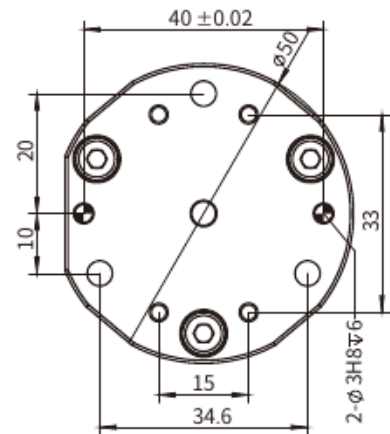
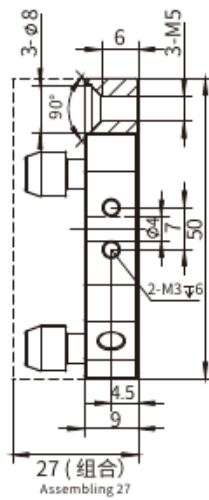
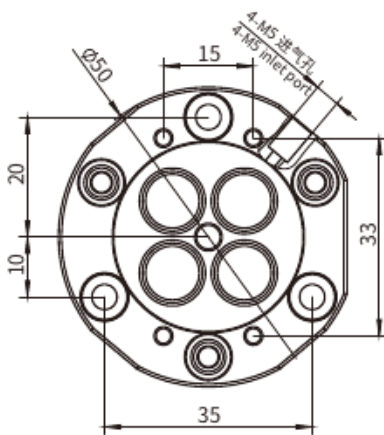

Profile、SUSTube  
型材、钢管

Stents Module  
支架模组

Quick Changer  
快换

Grip Module  
夹具组件

Air Nipper  
气动剪刀

Vacuum Module  
真空组件

Accessory Components  
附件

# 快换连接板

Interface

## SIP-50B

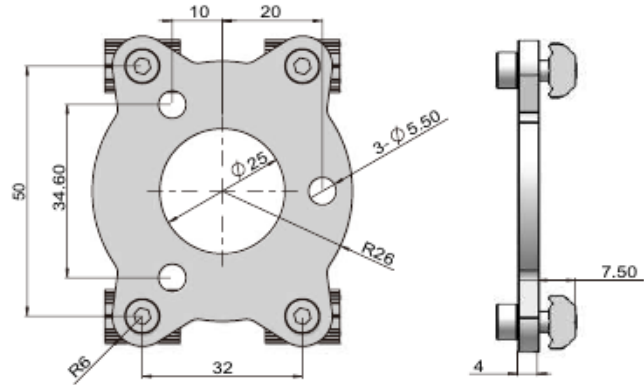

(螺钉套件选配) (Kit With Screws Option)

货号(PN)	7.Y00650
型号(Model)	SIP-50B
适用快换 (For quick changer)	QC-G50
厚度(T)	4mm
螺钉选配件 Accessorier selection	
螺丝(Screws)	PTC-M5L12*4
双齿平垫(Single hole shim)	PTS-M5*4
T型螺母(T-Nuts)	PTN-M5*4
总重量(Weight)	90g

注: 如需螺钉套件货号 and 型号加T 如: 型号SIP-50BT 货号7.Y00650-T  
 Note: If screw kits needed, add T to the part number and model number. eg: Model SIP-50BT Part number 7.Y00650-T.



Profile、SUS Tube  
型材、钢管

Stentis Module  
支架模组

Quick Changer  
快换

Grip Module  
夹具组件

Air Nipper  
气动剪刀

Vacuum Module  
真空组件

Accessory Components  
附件

# 圆形手动快换

## Round Manual Quick Changer

### QC-90



机器人侧  
Robot side

货号(PN)	8.Y00359
型号(Model)	QC-R90K



夹具侧  
Gripper side

货号(PN)	8.Y00033
型号(Model)	QC-G90

### 产品参数

#### Parameter

- |                          |   |
|--------------------------|---|
| 1.建议额定载荷:15 kg           | 1.Recommended rated load: 15kg                    |
| 2.介质:已过滤压缩空气             | 2. Medium: Filtered compressed air                |
| 3.压力范围:5-6bar            | 3. Pressure Range: 5-6bar                         |
| 4.温度范围:5-60°C            | 4. Temperature Range: 5-60°C                      |
| 5.垂直拉力:400N              | 5. Vertical Pulling Force F: 400N                 |
| 6.旋转扭矩:100Nm             | 6. Rotating Torque Mt: 100Nm                      |
| 7.翻转扭矩:60Nm              | 7. Reversal Torque Mb: 60Nm                       |
| 8.机器人侧重量:318g            | 8. Robot side weight: 318g                        |
| 9.治具侧重量:227g             | 9. Gripper side weight: 227g                      |
| 10.位置重复精度(X,Y&Z):±0.05mm | 10. Repeatability accuracy(X,Y&Z): ±0.05mm        |
| 11.颜色:古铜色                | 11. Colour: Brass                                 |
| 12.直通型气孔尺寸(数量):(8) G1/8  | 12. Size of straight air hole(quantity): (8) G1/8 |

### 模块类型

#### Module Type

产品图 Product	产品名称 Product name	型号 Model	货号 PN	I/O连接类型 I/O connection type	工作电流 Working current	连接线 Cable	重量 Weight
	机械手侧信号模块 Robot side signal module	QCSM-9R2	7.Y00862	9针D-SUB	MAX 3A	R9-1000 (1.Y06423)	31.5g
	治具侧信号模块 Gripper side signal module	QCSM-9G2	7.Y00863	9针D-SUB	MAX 3A	G9-1000 (1.Y06424)	31g

\*R9-1000、G9-1000选配, 连接线缆长为1米

\*R9-1000、G9-1000 option, the cable's length is 1 meter

# 圆形手动快换

## Round Manual Quick Changer

### 机器人侧 Robot side

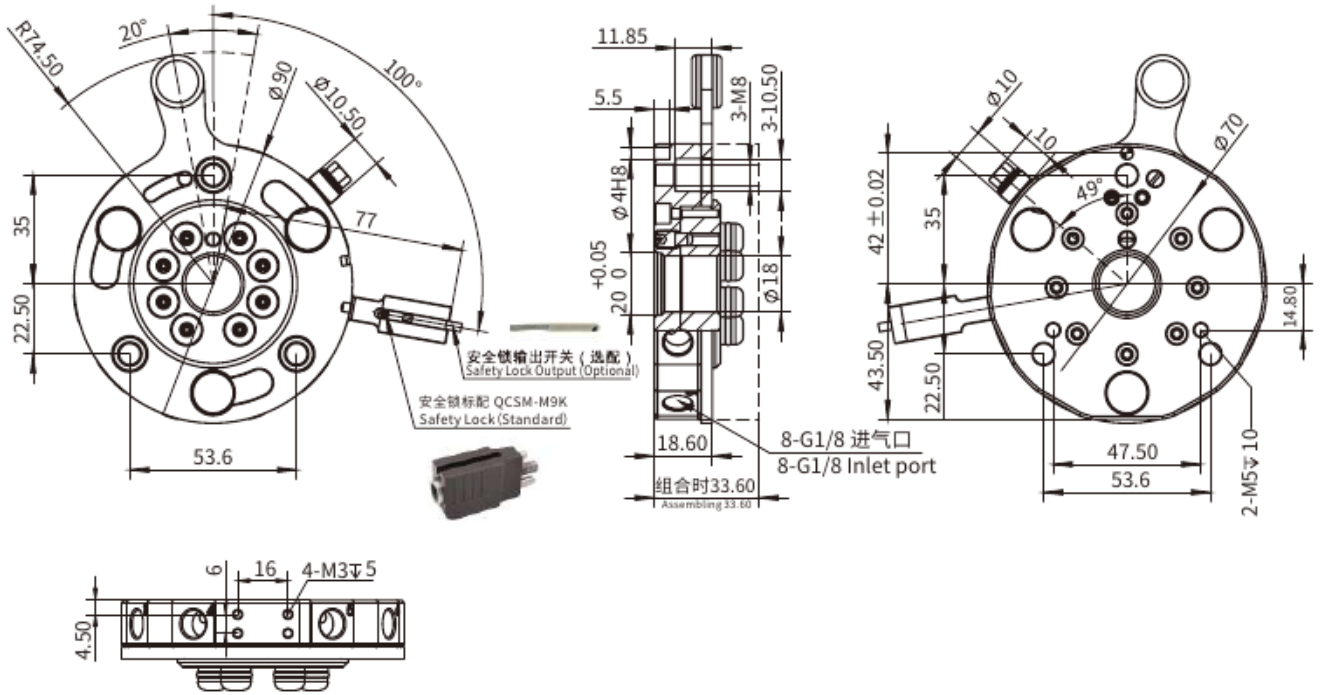

### 夹具侧 Gripper side

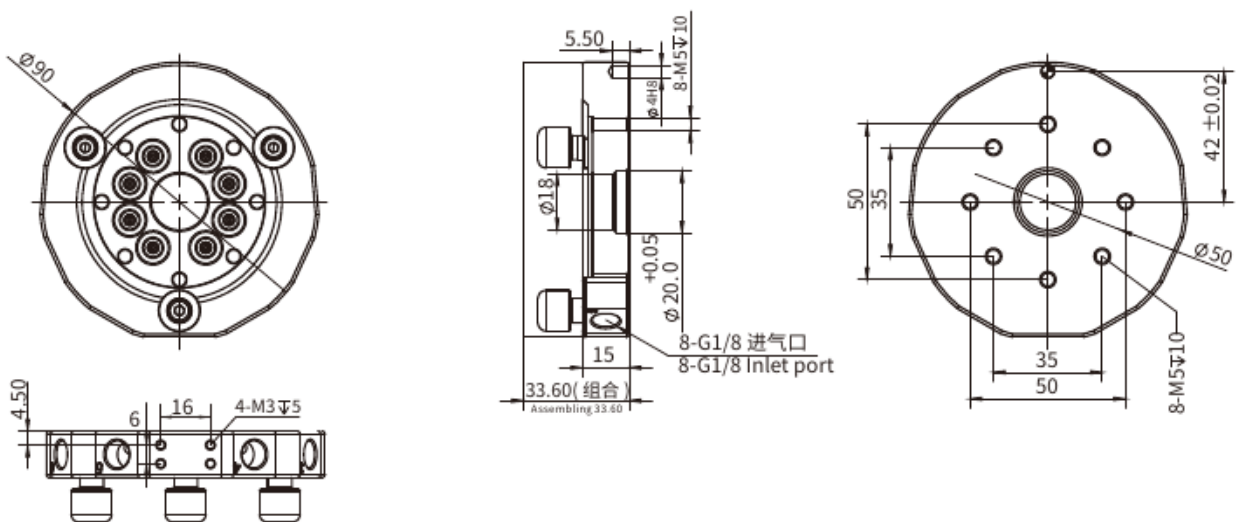

Profile、SUS Tube  
型材、钢管

Stentis Module  
支架模组

Quick Changer  
快换

Grip Module  
夹具组件

Air Nipper  
气动剪刀

Vacuum Module  
真空组件

Accessory Components  
附件

# 圆形手动快换带安全阀 NEW

## Round Manual Quick Changer Coupling with Safety Valve

### QCX-R90K



机器人侧  
Robot side

货号(PN)	8.Y01391
型号(Model)	QCX-R90K



夹具侧  
Gripper side

货号(PN)	8.Y00033(G)
型号(Model)	QC-G90(G)

### 产品参数

#### Parameter

- |                             |  |
|-----------------------------|--|
| 1. 建议额定载荷: 15 kg            | 1. Recommended rated load: 15kg                          |
| 2. 介质: 已过滤压缩空气              | 2. Medium: Filtered compressed air                       |
| 3. 压力范围: 5-6bar             | 3. Pressure Range: 5-6bar                                |
| 4. 温度范围: 5-60°C             | 4. Temperature Range: 5-60°C                             |
| 5. 垂直拉力: 400N               | 5. Vertical Pulling Force F: 400N                        |
| 6. 旋转扭矩: 100Nm              | 6. Rotating Torque Mt: 100Nm                             |
| 7. 翻转扭矩: 60Nm               | 7. Reversal Torque Mb: 60Nm                              |
| 8. 机器人侧重量: 610g             | 8. Robot side weight: 610g                               |
| 9. 治具侧重量: 227g              | 9. Gripper side weight: 227g                             |
| 10. 位置重复精度 (X,Y&Z): ±0.05mm | 10. Repeatability accuracy(X,Y&Z): ±0.05mm               |
| 11. 直通型气孔尺寸 (数量): (8) G1/8  | 11. Size of straight air hole(quantity): (8) G1/8        |
| 12. 增加安全阀关闭压缩空气             | 12. Increase the safety valve to shut off compressed air |

### 机器人侧

#### Robot side

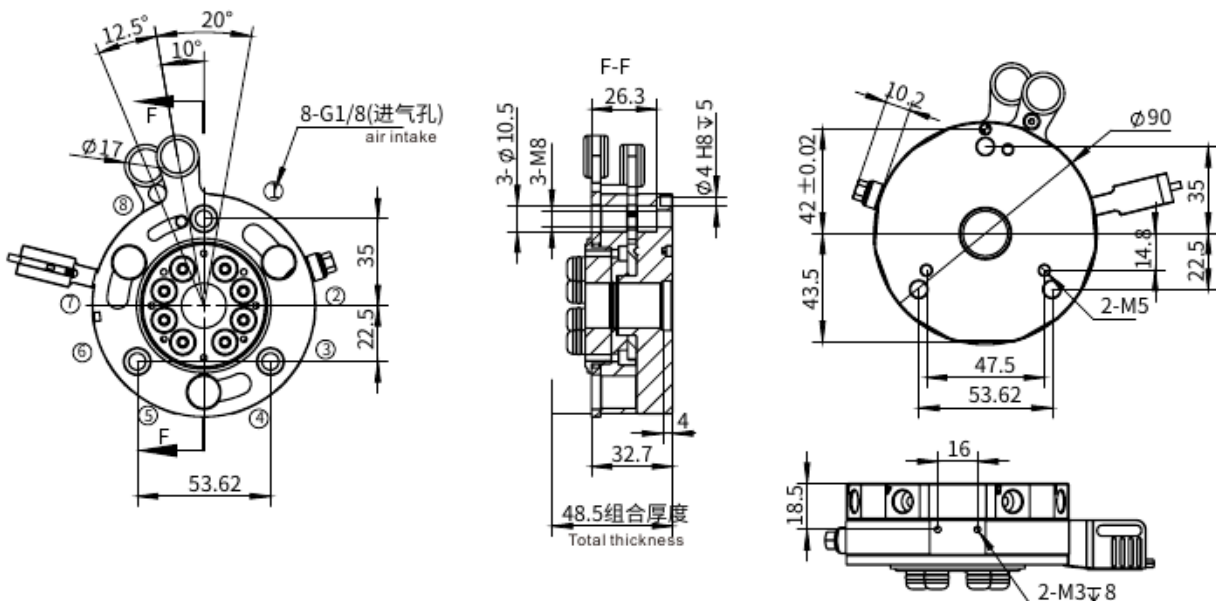

# 圆形手动快换带安全阀 NEW

Round Manual Quick Changer Coupling with Safety Valve

## 夹具侧

Gripper side

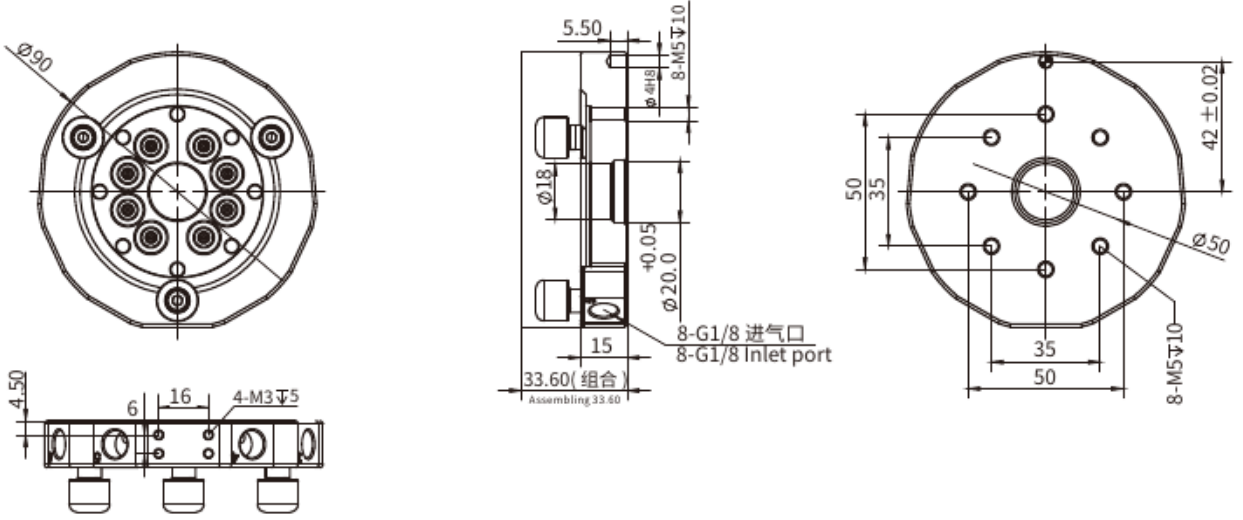

Profile、SUS Tube  
型材、钢管

Stents Module  
支架模组

Quick Changer  
快换

Grip Module  
夹具组件

Air Nipper  
气动剪刀

Vacuum Module  
真空组件

Accessory Components  
附件

# 快换连接板

Interface

## SIP-90B



(螺钉套件选配) (Kit With Screws Option)

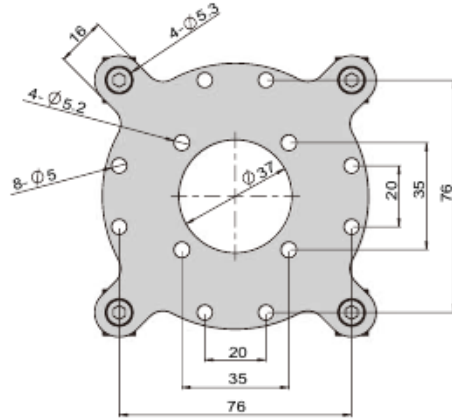

货号(PN)	7.Y00634
型号(Model)	SIP-90B
适用快换 (For quick changer)	QC-G90
厚度(T)	3mm
螺钉选配件 Accessorier selection	
螺丝(Screws)	PTC-M5L12*4
双齿平垫(Single hole shim)	PTS-M5*4
T型螺母(T-Nuts)	PTN-M5*4
总重量(Weight)	190g

注: 如需螺钉套件货号 and 型号加T 如: 型号SIP-90BT 货号7.Y00634-T

Note: If screw kits needed, add T to the part number and model number. eg: Model SIP-90BT Part number 7.Y00634-T



Profile- SUS Tube  
型材、钢管

Stents Module  
支架模组

Quick Changer  
快换

Grip Module  
夹具组件

Air Nipper  
气动剪刀

Vacuum Module  
真空组件

Accessory Components  
附件

# 圆形手动快换

## Round Manual Quick Changer

### QC-150



机器人侧  
Robot side



夹具侧  
Gripper side

货号(PN)	8.Y00376
型号(Model)	QC-R150K

货号(PN)	8.Y00377
型号(Model)	QC-G150

### 产品参数

#### Parameter

- |                             |   |
|-----------------------------|---|
| 1. 建议额定载荷: 35 kg            | 1. Recommended rated load: 35kg                     |
| 2. 介质: 已过滤压缩空气              | 2. Medium: Filtered compressed air                  |
| 3. 压力范围: 5-6bar             | 3. Pressure Range: 5-6bar                           |
| 4. 温度范围: 5-60°C             | 4. Temperature Range: 5-60°C                        |
| 5. 垂直拉力: 1000N              | 5. Vertical Pulling Force F: 1000N                  |
| 6. 旋转扭矩: 250Nm              | 6. Rotating Torque Mt: 250Nm                        |
| 7. 翻转扭矩: 150Nm              | 7. Reversal Torque Mb: 150Nm                        |
| 8. 机器人侧重量: 1159g            | 8. Robot side weight: 1159g                         |
| 9. 治具侧重量: 837g              | 9. Gripper side weight: 837g                        |
| 10. 位置重复精度 (X,Y&Z): ±0.05mm | 10. Repeatability accuracy(X,Y&Z): ±0.05mm          |
| 11. 颜色: 黑色                  | 11. Colour: Black                                   |
| 12. 直通型气孔尺寸(数量): (10) G1/4  | 12. Size of straight air hole (quantity): (10) G1/4 |

### 模块类型

#### Module Type

产品图 Product	产品名称 Product name	型号 Model	货号 PN	I/O连接类型 I/O connection type	工作电流 Working current	连接线 Cable	重量 Weight
	机械手侧信号模块 Robot side signal module	QCSM-9R3	7.Y00819	9针D-SUB	MAX 3A	R9-1000 (1.Y06423)	31g
	治具侧信号模块 Gripper side signal module	QCSM-9G3	7.Y00820	9针D-SUB	MAX 3A	G9-1000 (1.Y06424)	32g

\*R9-1000、G9-1000选配, 连接线线长为1米  
\*R9-1000、G9-1000 option, the cable's length is 1 meter

Profile, SUS Tube  
型材、钢管

Stents Module  
支架模组

Quick Changer  
快换

Grip Module  
夹具组件

Air Nipper  
气动剪刀

Vacuum Module  
真空组件

Accessory Components  
附件

# 圆形手动快换

## Round Manual Quick Changer

### 机器人侧 Robot side

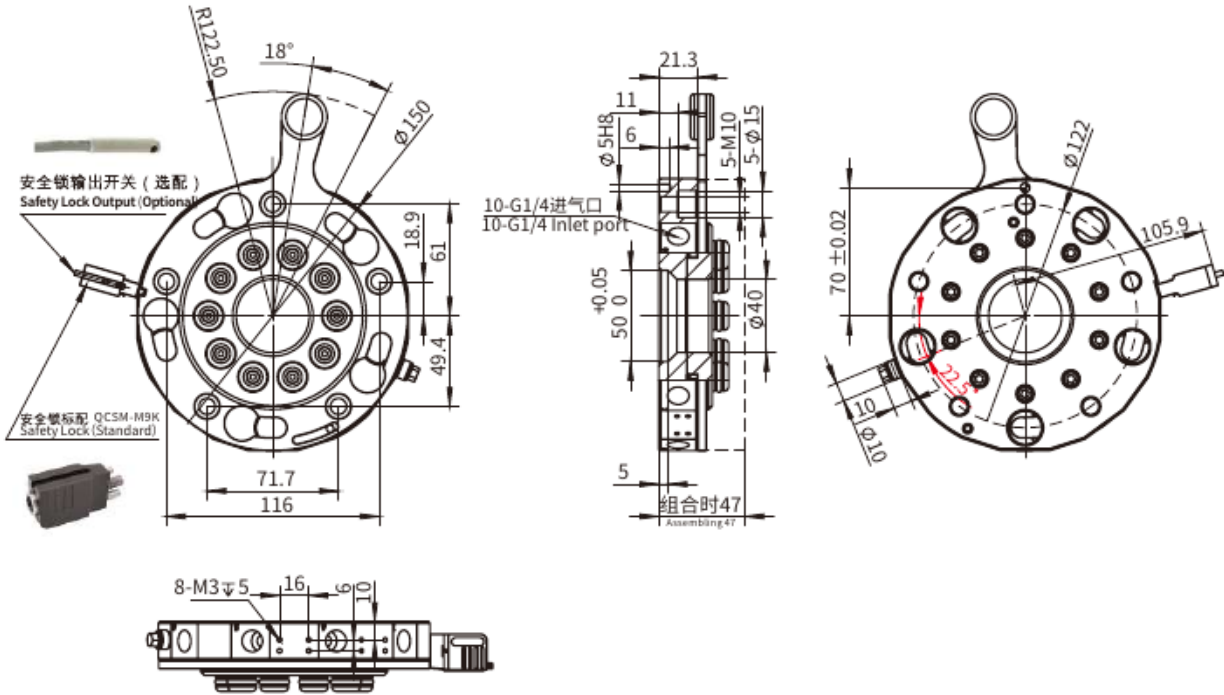

### 夹具侧 Gripper side

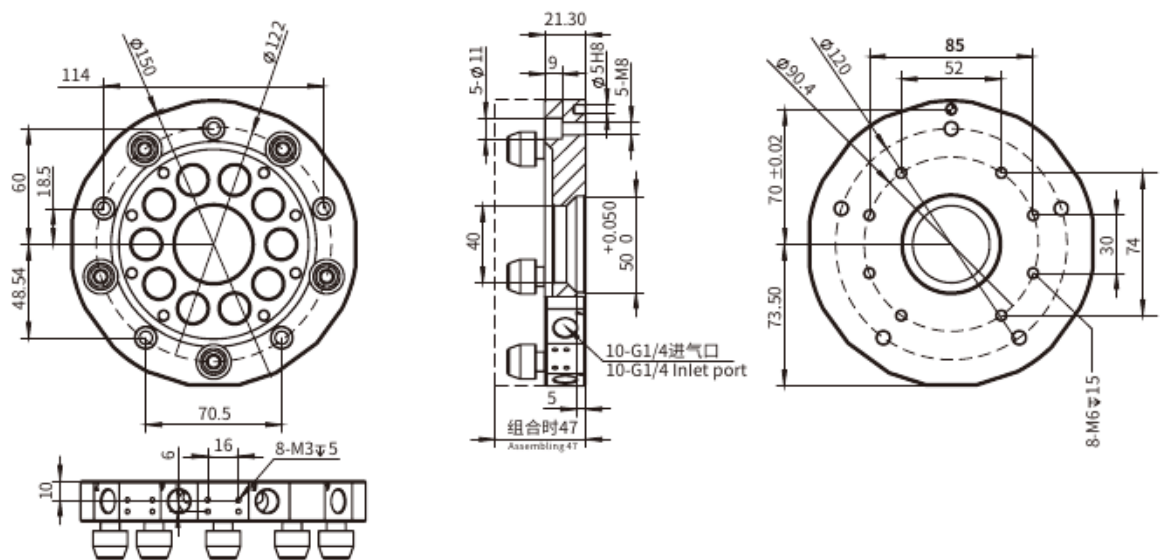

型材、钢管  
Profile、SUS Tube

支架模组  
Stents Module

快换  
Quick Changer

夹具组件  
Grip Module

气动剪刀  
Air Nipper

真空组件  
Vacuum Module

附件  
Accessory Components

# 圆形手动快换带安全阀 NEW

## Round Manual Quick Changer Coupling with Safety Valve

### QCX-R150K



机器人侧  
Robot side

货号(PN)	8.Y01392
型号(Model)	QCX-R150K

### 产品参数

#### Parameter

- |                             |  |
|-----------------------------|--|
| 1. 建议额定载荷: 35 kg            | 1. Recommended rated load: 35kg                          |
| 2. 介质: 已过滤压缩空气              | 2. Medium: Filtered compressed air                       |
| 3. 压力范围: 5-6bar             | 3. Pressure Range: 5-6bar                                |
| 4. 温度范围: 5-60°C             | 4. Temperature Range: 5-60°C                             |
| 5. 垂直拉力: 1000N              | 5. Vertical Pulling Force F: 1000N                       |
| 6. 旋转扭矩: 250Nm              | 6. Rotating Torque Mt: 250Nm                             |
| 7. 翻转扭矩: 150Nm              | 7. Reversal Torque Mb: 150Nm                             |
| 8. 机器人侧重量: 2214g            | 8. Robot side weight: 2214g                              |
| 9. 位置重复精度 (X,Y&Z): ±0.05mm  | 9. Repeatability accuracy(X,Y&Z): ±0.05mm                |
| 10. 直通型气孔尺寸 (数量): (10) G1/4 | 10. Size of straight air hole (quantity): (10) G1/4      |
| 11. 增加安全阀关闭压缩空气             | 11. Increase the safety valve to shut off compressed air |

### 机器人侧

#### Robot side

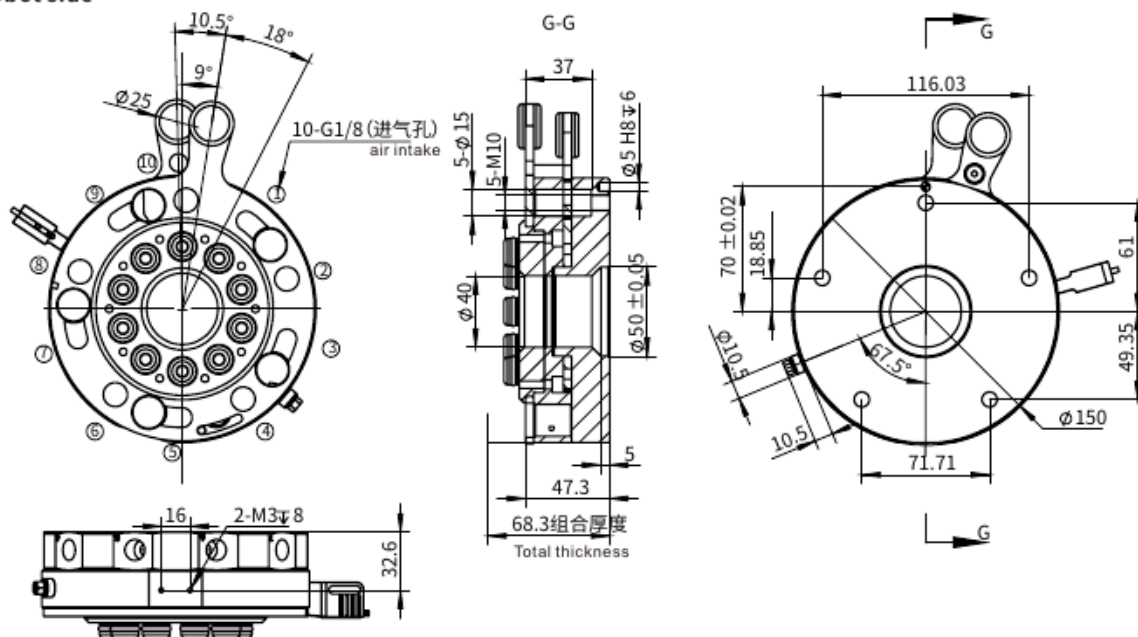

# 圆形手动快换

## Round Manual Quick Changer

### QC-160

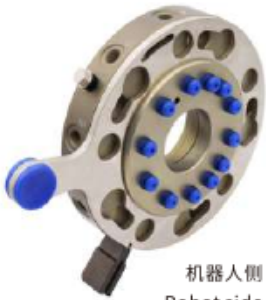

机器人侧  
Robot side

货号(PN)	8.Y00360
型号(Model)	QC-R160K



夹具侧  
Gripper side

货号(PN)	8.Y00053
型号(Model)	QC-G160

### 产品参数

#### Parameter

- |                             |   |
|-----------------------------|---|
| 1. 建议额定载荷: 35 kg            | 1. Recommended rated load: 35kg                     |
| 2. 介质: 已过滤压缩空气              | 2. Medium: Filtered compressed air                  |
| 3. 压力范围: 5-6bar             | 3. Pressure Range: 5-6bar                           |
| 4. 温度范围: 5-60°C             | 4. Temperature Range: 5-60°C                        |
| 5. 垂直拉力: 1000N              | 5. Vertical Pulling Force F: 1000N                  |
| 6. 旋转扭矩: 250Nm              | 6. Rotating Torque Mt: 250Nm                        |
| 7. 翻转扭矩: 150Nm              | 7. Reversal Torque Mb: 150Nm                        |
| 8. 机器人侧重量: 1200g            | 8. Robot side weight: 1200g                         |
| 9. 治具侧重量: 900g              | 9. Gripper side weight: 900g                        |
| 10. 位置重复精度 (X,Y&Z): ±0.05mm | 10. Repeatability accuracy(X,Y&Z): ±0.05mm          |
| 11. 颜色: 古铜色                 | 11. Colour: Brass                                   |
| 12. 直通型气孔尺寸 (数量): (12) G1/8 | 12. Size of straight air hole (quantity): (12) G1/8 |

### 模块类型

#### Module Type

产品图 Product	产品名称 Product name	型号 Model	货号 PN	I/O连接类型 I/O connection type	工作电流 Working current	连接线 Cable	重量 Weight
	机械手侧信号模块 Robot side signal module	QCSM-9R2	7.Y00862	9针D-SUB	MAX 3A	R9-1000 (1.Y06423)	32.6g
	治具侧信号模块 Gripper side signal module	QCSM-9G2	7.Y00863	9针D-SUB	MAX 3A	G9-1000 (1.Y06424)	32.6g

\*R9-1000, G9-1000选配, 连接线线长为1米

\*R9-1000, G9-1000 option, the cable's length is 1 meter

# 圆形手动快换

## Round Manual Quick Changer

### 机器人侧 Robot side

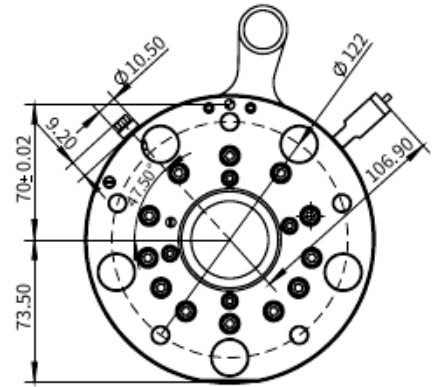
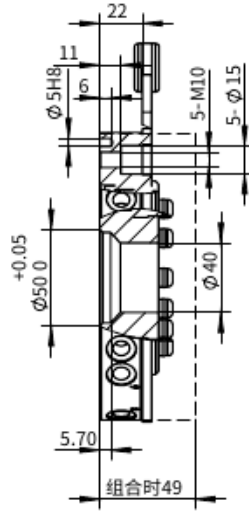
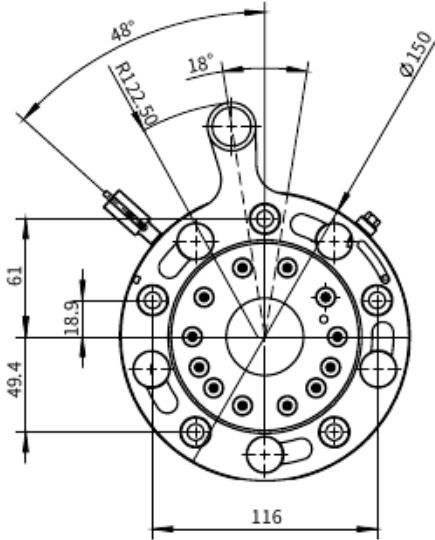
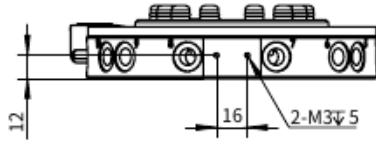

### 夹具侧 Gripper side

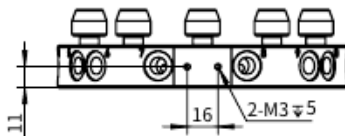
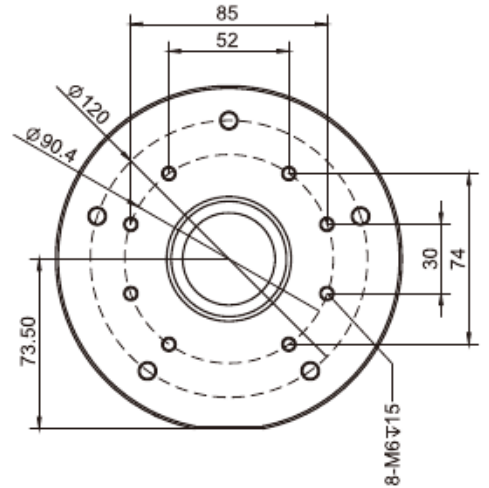
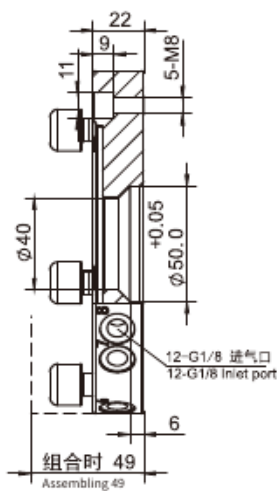
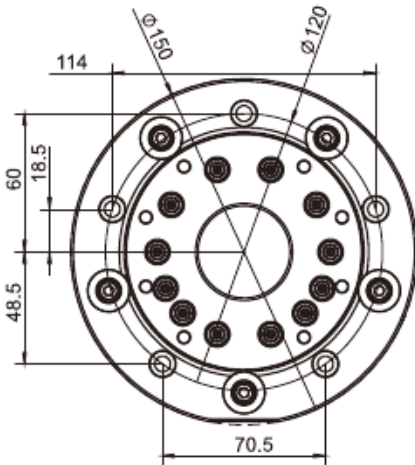

Profile、SUS Tube  
型材、钢管

Stents Module  
支架模组

Quick Changer  
快换

Grip Module  
夹具组件

Air Nipper  
气筒刀

Vacuum Module  
真空组件

Accessory Components  
附件

# 快换连接板

Interface

## SIP-160B



(螺钉套件选配) (Kit With Screws Option)

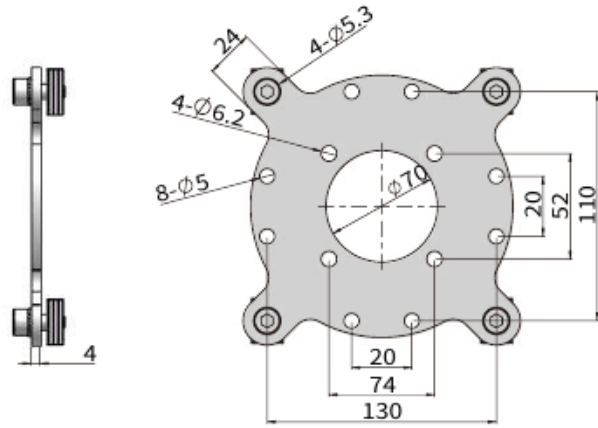

货号(PN)	7.Y00635
型号(Model)	SIP-160B
适用快换 (For quick changer)	QC-G150/QC-G160
厚度(T)	4mm
螺钉选配件 Accessorier selection	
螺丝(Screws)	PTC-M5L12*4
双齿平垫(Single hole shim)	PTS-M5*4
T型螺母(T-Nuts)	PTN-M5*4
总重量(Weight)	540g

注: 如需螺钉套件货号 and 型号加 T 如: 型号 SIP-160BT 货号 7.Y00635-T

Note: If screw kits needed, add T to the part number and model number. eg: Model SIP-160BT Part number 7.Y00635-T



Profile- SUS Tube  
型材、钢管

Stents Module  
支架模组

Quick Changer  
快换

Grip Module  
夹具组件

Air Nipper  
气动剪刀

Vacuum Module  
真空组件

Accessory Components  
附件

# 圆形手动快换

## Round Manual Quick Changer

### QC-200



机器人侧  
Robot side



夹具侧  
Gripper side

货号(PN)	8.Y00209
型号(Model)	QC-R200K

货号(PN)	8.Y00208
型号(Model)	QC-G200

### 产品参数

#### Parameter

- |   |   |
|---|---|
| <ol style="list-style-type: none"> <li>1. 建议额定载荷: 75 kg</li> <li>2. 介质: 已过滤压缩空气</li> <li>3. 压力范围: 5-6bar</li> <li>4. 温度范围: 5-60°C</li> <li>5. 垂直拉力: 2000N</li> <li>6. 旋转扭矩: 600Nm</li> <li>7. 翻转扭矩: 300Nm</li> <li>8. 机器人侧重量: 2640g</li> <li>9. 治具侧重量: 1890g</li> <li>10. 位置重复精度 (X,Y&amp;Z): ±0.05mm</li> <li>11. 颜色: 黑色</li> <li>12. 直通型气孔尺寸 (数量): (12) G1/4</li> </ol> | <ol style="list-style-type: none"> <li>1. Recommended rated load: 75kg</li> <li>2. Medium: Filtered compressed air</li> <li>3. Pressure Range: 5-6bar</li> <li>4. Temperature Range: 5-60°C</li> <li>5. Vertical Pulling Force F: 2000N</li> <li>6. Rotating Torque Mt: 600Nm</li> <li>7. Reversal Torque Mb: 300Nm</li> <li>8. Robot side weight: 2640g</li> <li>9. Gripper side weight: 1890g</li> <li>10. Repeatability accuracy(X, Y&amp;Z): ±0.05mm</li> <li>11. Colour: Black</li> <li>12. Size of straight air hole (quantity): (12) G1/4</li> </ol> |
|---|---|

### 模块类型

#### Module Type

产品图 Product	产品名称 Product name	型号 Model	货号 PN	I/O连接类型 I/O connection type	工作电流 Working current	连接线 Cable	重量 Weight
	机械手侧信号模块 Robot side signal module	QCSM-9R4	7.Y00821	9针D-SUB	MAX 3A	R9-1000 (1.Y06423)	32.6g
	治具侧信号模块 Gripper side signal module	QCSM-9G4	7.Y00822	9针D-SUB	MAX 3A	G9-1000 (1.Y06424)	32.6g

\*R9-1000, G9-1000选配, 连接线线长为1米  
\*R9-1000, G9-1000 option, the cable's length is 1 meter

# 圆形手动快换

## Round Manual Quick Changer

### 机器人侧 Robot side

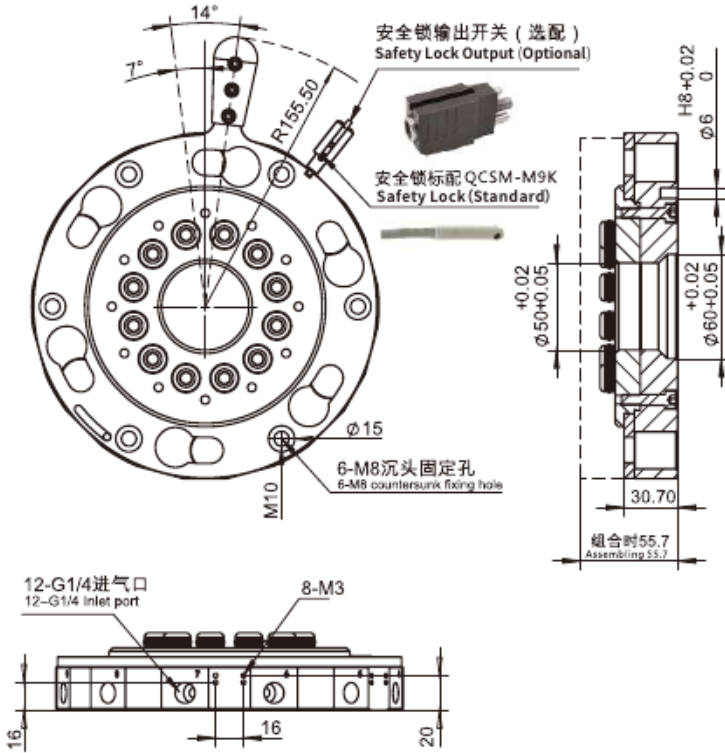

### 夹具侧 Gripper side

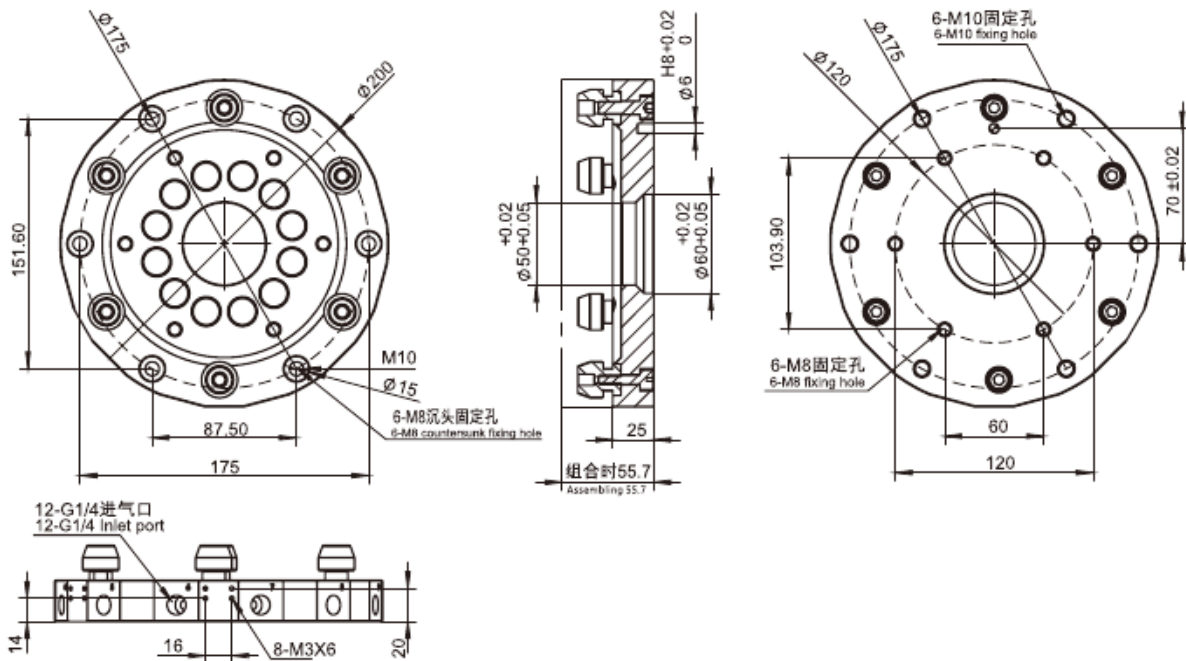

Profile- SUS Tube  
型材、钢管

Stents Module  
支架模组

Quick Changer  
快换

Grip Module  
夹具组件

Air Nipper  
气动剪刀

Vacuum Module  
真空组件

Accessory Components  
附件

# 圆形手动快换带安全阀 NEW

Round Manual Quick Changer Coupling with Safety Valve

## QCX-R200K



机器人侧  
Robot side

货号(PN)	8.Y01393
型号(Model)	QCX-R200K

### 产品参数

#### Parameter

1. 建议额定载荷: 75 kg
2. 介质: 已过滤压缩空气
3. 压力范围: 5-6bar
4. 温度范围: 5-60°C
5. 垂直拉力: 2000N
6. 旋转扭矩: 600Nm
7. 翻转扭矩: 300Nm
8. 机器人侧重量: 4968g
9. 位置重复精度 (X,Y&Z): ±0.05mm
10. 直通型气孔尺寸 (数量): (12) G1/4
11. 增加安全阀关闭压缩空气

1. Recommended rated load: 75kg
2. Medium: Filtered compressed air
3. Pressure Range: 5-6bar
4. Temperature Range: 5-60°C
5. Vertical Pulling Force F: 2000N
6. Rotating Torque Mt: 600Nm
7. Reversal Torque Mb: 300Nm
8. Robot side weight: 4968g
9. Repeatability accuracy(X,Y&Z): ±0.05mm
10. Size of straight air hole (quantity): (12) G1/4
11. Increase the safety valve to shut off compressed air

### 机器人侧

#### Robot side

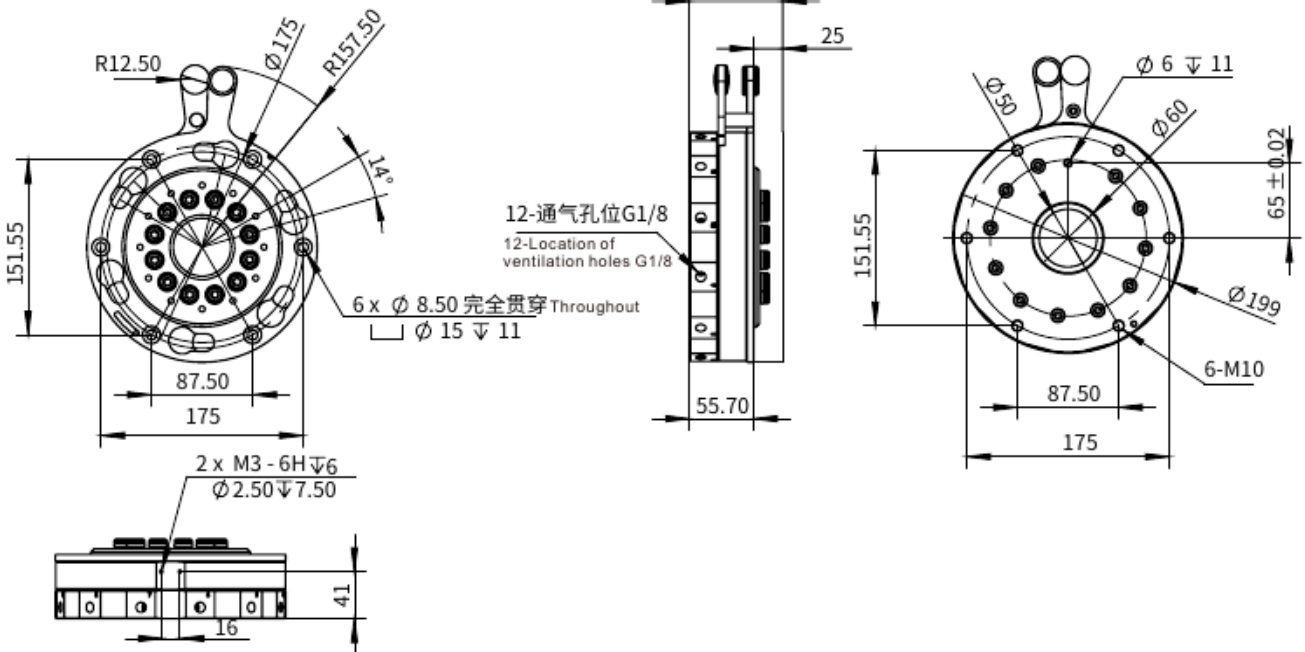

Profile, SUS Tube  
型材、钢管

Stents Module  
支架模组

Quick Changer  
快换

Grip Module  
夹具组件

Air Nipper  
气动剪刀

Vacuum Module  
真空组件

Accessory Components  
附件

# 快换连接板

Interface

## SIP-200B

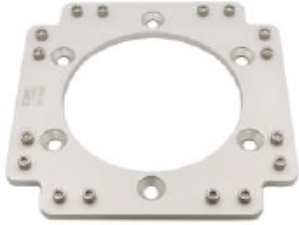

(螺钉套件选配) (Kit With Screws Option)

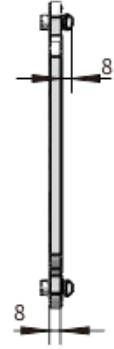
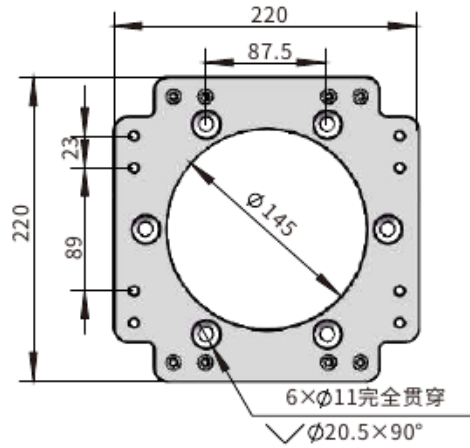

货号(PN)	7.Y00865
型号(Model)	SIP-200B
适用快换 (For quick changer)	QC-G200
厚度(T)	8mm
总重量(Weight)	578g
螺钉选配件 Accessorier selection	
螺丝(Screws)	PTC-M5L16*16
双齿平垫(Single hole shim)	PTS-M5*16
T型螺母(T-Nuts)	PTN-M5*16



Profile- SUS Tube  
型材、钢管

Stents Module  
支架模组

Quick Changer  
快换

Grip Module  
夹具组件

Air Nipper  
气动剪刀

Vacuum Module  
真空组件

Accessory Components  
附件

# 手动快换

## Manual Quick Changer

### QC-09

Profile, SUS Tube  
型材、钢管

Stents Module  
支架模组

Quick Changer  
快换

Grip Module  
夹具组件

Air Nipper  
气动剪刀

Vacuum Module  
真空组件

Accessory Components  
附件



机器人侧  
Robot side

货号(PN)	8.Y01237
型号(Model)	QC-R09
重量(Weight)	168g



夹具侧  
Gripper side

货号(PN)	8.Y01238
型号(Model)	QC-G09
重量(Weight)	82g

### 机器人侧

#### Robot side

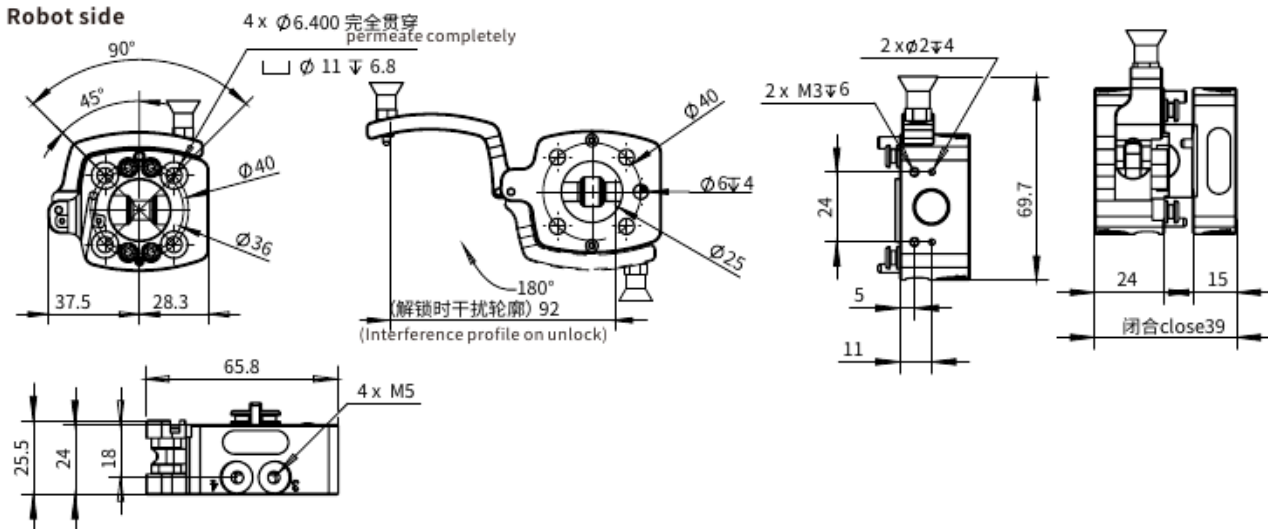

### 夹具侧

#### Gripper side

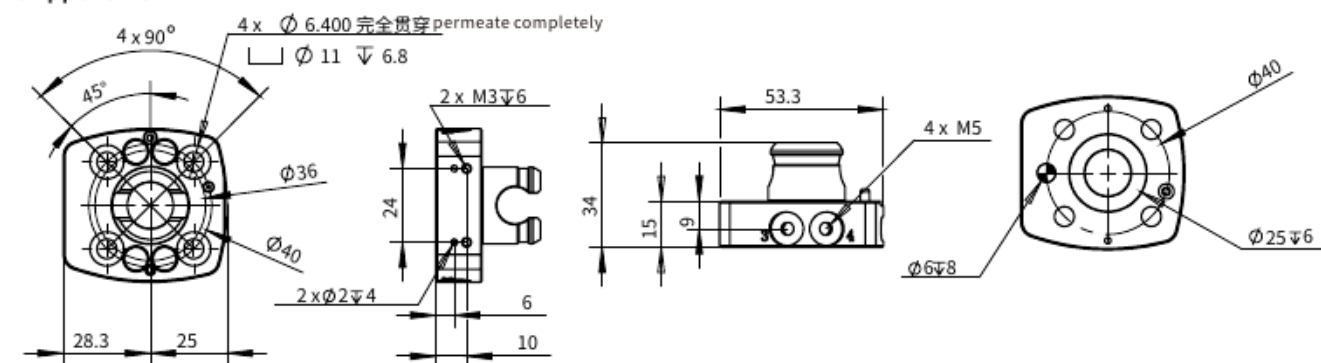

负载 (Load)	气路数量 (Number of air lines)	气路接口 (Air connection)	机器人侧连接法兰 (Robot side connection flange)	重复定位精度mm (Repeat Positioning Accuracy)	贴合后尺寸mm (Dimensions after lamination)
9kg	4	M5	ISO 9409-1-40-4-M6	0.02	39

#### 手动快换系统:

闭合手柄即可通过一个锁定轴锁定,快换机器人侧和工具侧之间无间隙,无需使用任何其他工具。打开手柄即可解锁系统,从而拆下快换工具侧。可以通过集成气路向末端执行器供给压缩空气或抽真空。

#### Manual quick-change system:

By closing the handle, the system is locked by a locking axis and there is no gap between the quick-change robot side and the tool side, without the need to use any other tool. The system is unlocked by opening the handle. The quick-change tool side can be removed. Compressed air or vacuum can be supplied to the end-effector by means of an integrated pneumatic circuit.

# 手动快换

## Manual Quick Changer

### QC-11



机器人侧  
Robot side

货号(PN)	8.Y01239
型号(Model)	QC-R11
重量(Weight)	268g



夹具侧  
Gripper side

货号(PN)	8.Y01240
型号(Model)	QC-G11
重量(Weight)	136g

### 机器人侧

#### Robot side

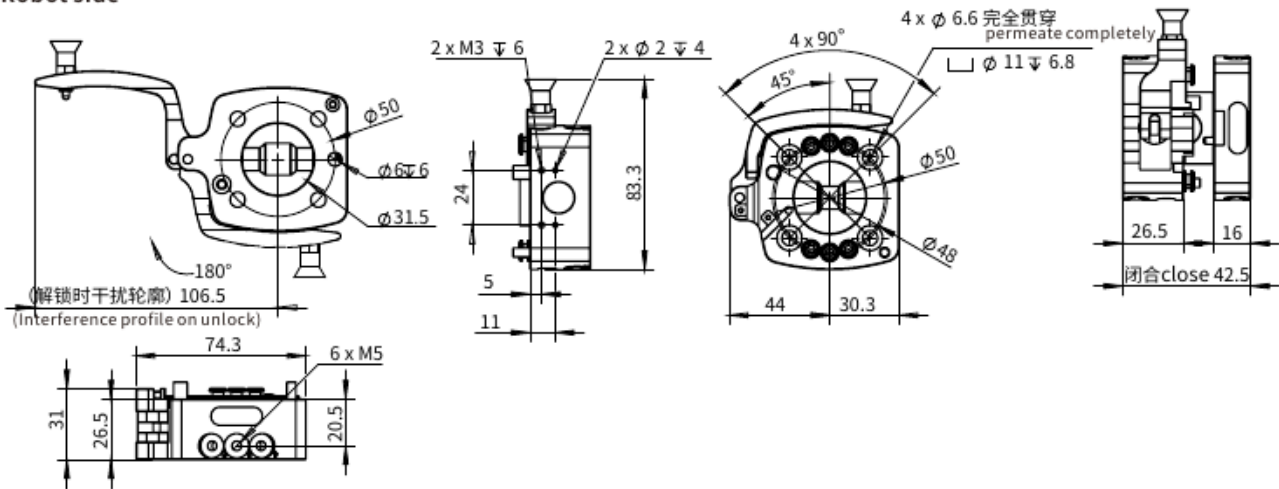

### 夹具侧

#### Gripper side

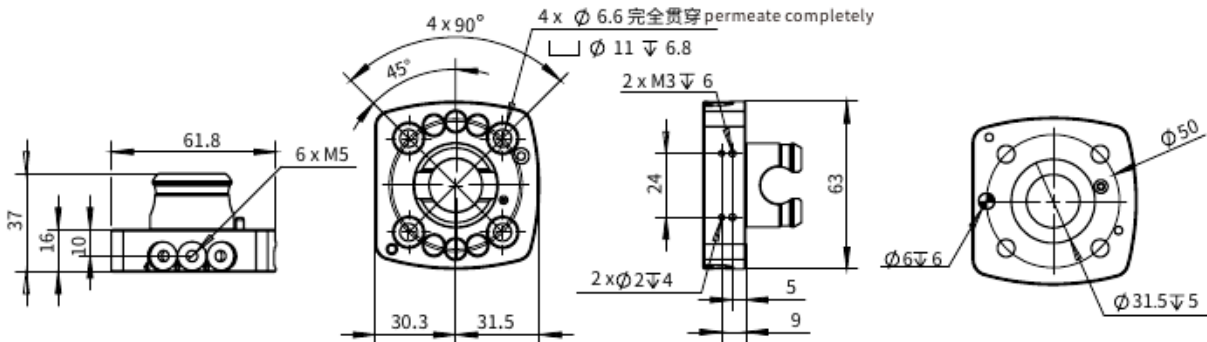

负载 (Load)	气路数量 (Number of air lines)	气路接口 (Air connection)	机器人侧连接法兰 (Robot side connection flange)	重复定位精度mm (Repeat Positioning Accuracy)	贴合后尺寸mm (Dimensions after lamination)
11kg	6	M5	ISO 9409-1-50-4-M6	0.02	42.5

#### 手动快换系统:

闭合手柄即可通过一个锁定轴锁定,快换机器人侧和工具侧之间无间隙,无需使用任何其他工具。打开手柄即可解锁系统,从而拆下快换工具侧。可以通过集成气路向末端执行器供给压缩空气或抽真空。

#### Manual quick-change system:

By closing the handle, the system is locked by a locking axis and there is no gap between the quick-change robot side and the tool side, without the need to use any other tool. The system is unlocked by opening the handle. The quick-change tool side can be removed. Compressed air or vacuum can be supplied to the end-effector by means of an integrated pneumatic circuit.

# 手动快换

## Manual Quick Changer

### QC-18



机器人侧  
Robot side

货号(PN)	8.Y01241
型号(Model)	QC-R18
重量(Weight)	503g



夹具侧  
Gripper side

货号(PN)	8.Y01242
型号(Model)	QC-G18
重量(Weight)	281g

### 机器人侧

#### Robot side

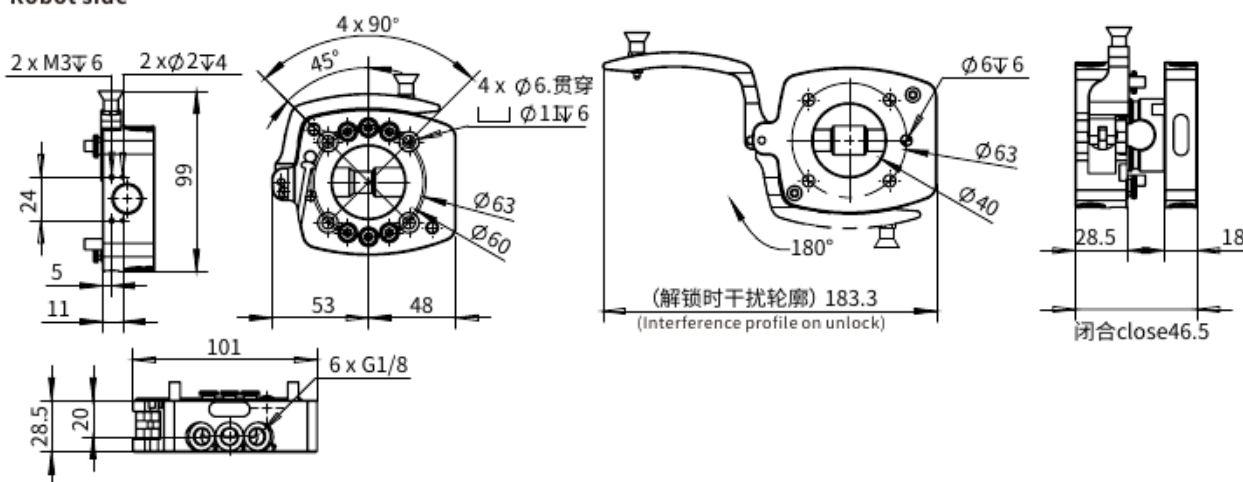

### 夹具侧

#### Gripper side

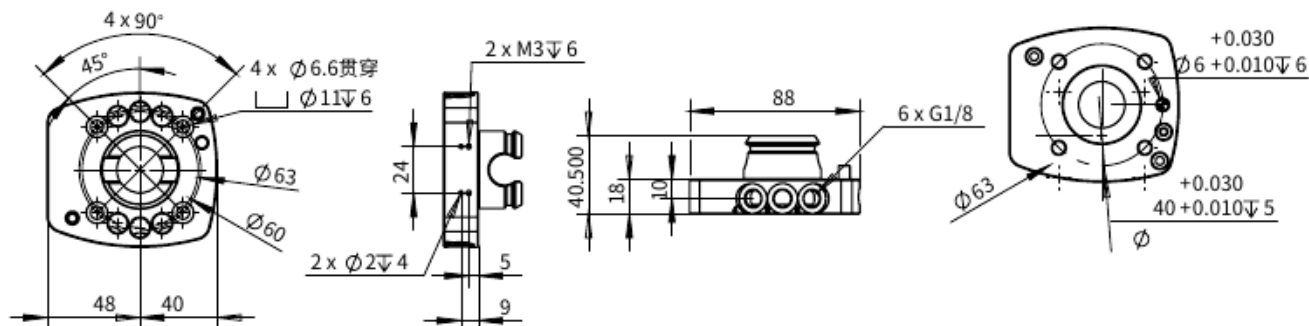

负载 (Load)	气路数量 (Number of air lines)	气路接口 (Air connection)	机器人侧连接法兰 (Robot side connection flange)	重复定位精度mm (Repeat Positioning Accuracy)	贴合后尺寸mm (Dimensions after lamination)
18kg	6	G1/8	ISO 9409-1-63-4-M6	0.02	46.5

#### 手动快换系统:

闭合手柄即可通过一个锁定轴锁定,快换机器人侧和工具侧之间无间隙,无需使用任何其他工具。打开手柄即可解锁系统,从而拆下快换工具侧。可以通过集成气路向末端执行器供给压缩空气或抽真空。

#### Manual quick-change system:

By closing the handle, the system is locked by a locking axis and there is no gap between the quick-change robot side and the tool side, without the need to use any other tool. The system is unlocked by opening the handle. The quick-change tool side can be removed. Compressed air or vacuum can be supplied to the end-effector by means of an integrated pneumatic circuit.

# 手动快换

## Manual Quick Changer

### QC-36



机器人侧  
Robot side

货号(PN)	8.Y01243
型号(Model)	QC-R36
重量(Weight)	754g



夹具侧  
Gripper side

货号(PN)	8.Y01244
型号(Model)	QC-G36
重量(Weight)	423g

### 机器人侧

#### Robot side

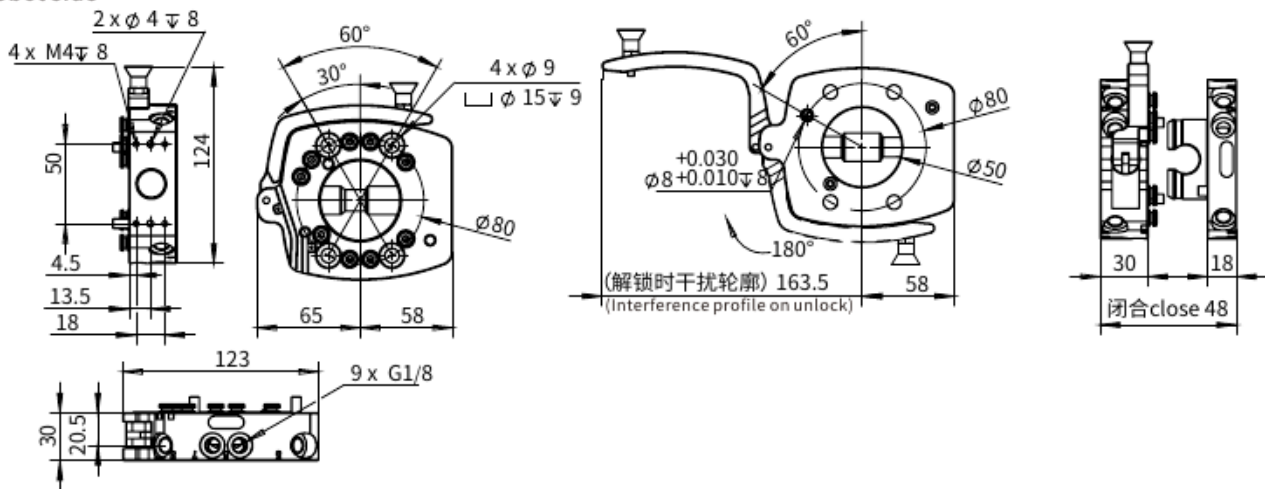

### 夹具侧

#### Gripper side

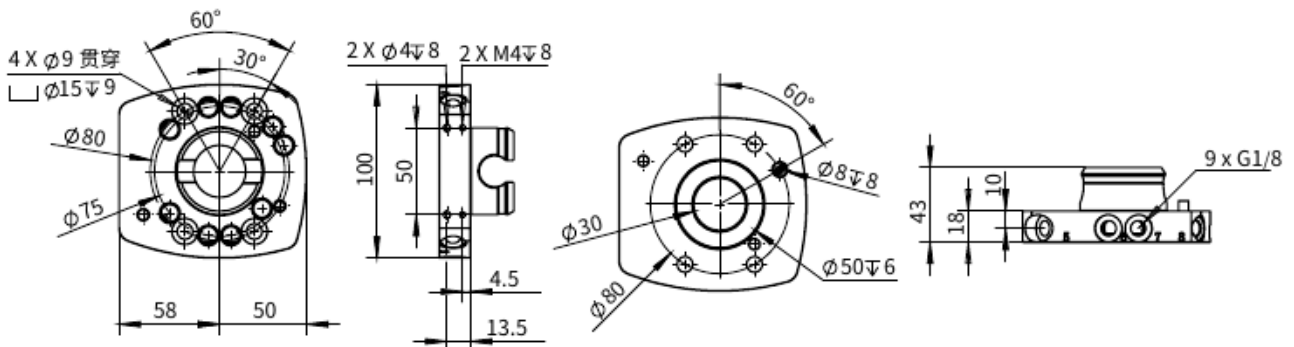

负载 (Load)	气路数量 (Number of air lines)	气路接口 (Air connection)	机器人侧连接法兰 (Robot side connection flange)	重复定位精度mm (Repeat Positioning Accuracy)	贴合后尺寸mm (Dimensions after lamination)
36kg	9	G1/8	ISO 9409-1-80-6-M8	0.02	48

#### 手动快换系统:

闭合手柄即可通过一个锁定轴锁定,快换机器人侧和工具侧之间无间隙,无需使用任何其他工具。打开手柄即可解锁系统,从而拆下快换工具侧。可以通过集成气路向末端执行器供给压缩空气或抽真空。

#### Manual quick-change system:

By closing the handle, the system is locked by a locking axis and there is no gap between the quick-change robot side and the tool side, without the need to use any other tool. The system is unlocked by opening the handle. The quick-change tool side can be removed. Compressed air or vacuum can be supplied to the end-effector by means of an integrated pneumatic circuit.

# 手动快换

## Manual Quick Changer

### QC-43



机器人侧  
Robot side



夹具侧  
Gripper side

货号(PN)	8.Y01245
型号(Model)	QC-R43
重量(Weight)	1439g

货号(PN)	8.Y01246
型号(Model)	QC-G43
重量(Weight)	1023g

### 机器人侧

#### Robot side

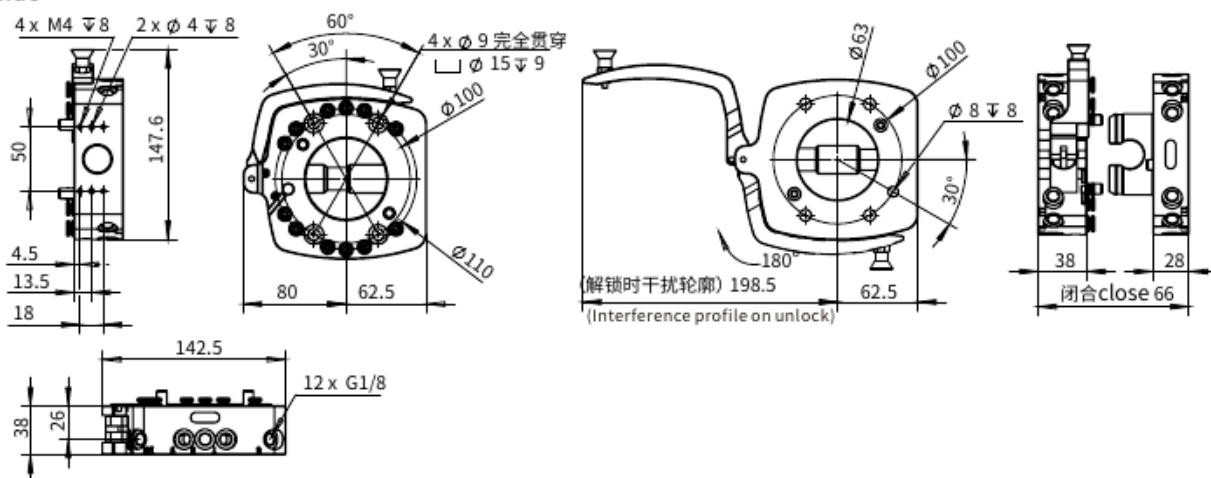

### 夹具侧

#### Gripper side

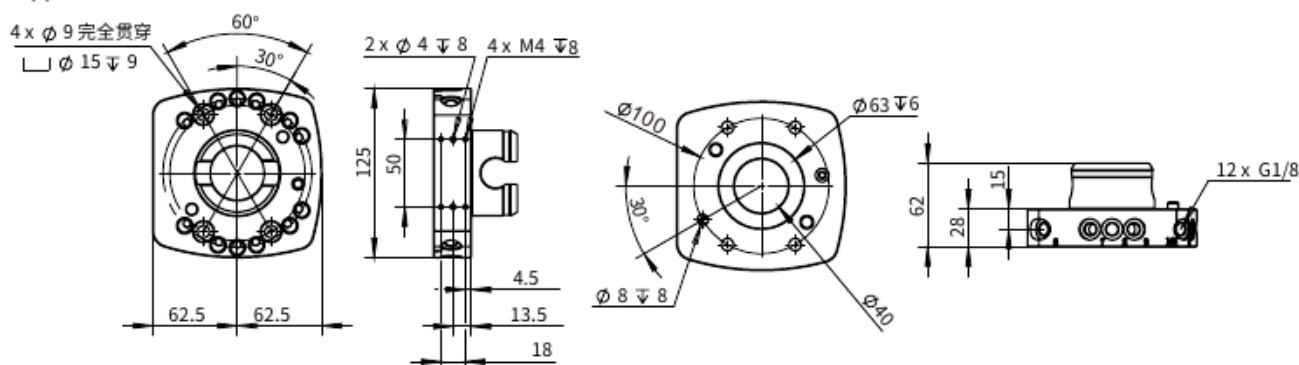

负载 (Load)	气路数量 (Number of air lines)	气路接口 (Air connection)	机器人侧连接法兰 (Robot side connection flange)	重复定位精度mm (Repeat Positioning Accuracy)	贴合后尺寸mm (Dimensions after lamination)
43kg	12	G1/8	ISO 9409-1-100-6-M8	0.02	66

#### 手动快换系统:

闭合手柄即可通过一个锁定轴锁定, 快换机器人侧和工具侧之间无间隙, 无需使用任何其他工具。打开手柄即可解锁系统, 从而拆下快换工具侧。可以通过集成气路向末端执行器供给压缩空气或抽真空。

#### Manual quick-change system:

By closing the handle, the system is locked by a locking axis and there is no gap between the quick-change robot side and the tool side, without the need to use any other tool. The system is unlocked by opening the handle. The quick-change tool side can be removed. Compressed air or vacuum can be supplied to the end-effector by means of an integrated pneumatic circuit.

# 手动快换

## Manual Quick Changer

### QC-58



机器人侧  
Robot side

货号(PN)	8.Y01247
型号(Model)	QC-R58
重量(Weight)	3018g



夹具侧  
Gripper side

货号(PN)	8.Y01248
型号(Model)	QC-G58
重量(Weight)	1658g

### 机器人侧

#### Robot side

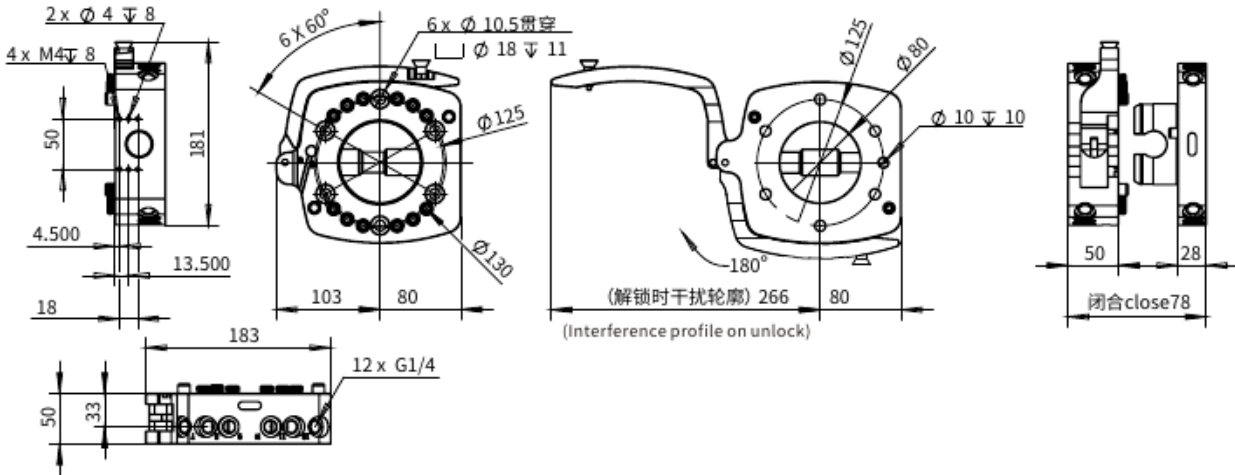

### 夹具侧

#### Gripper side

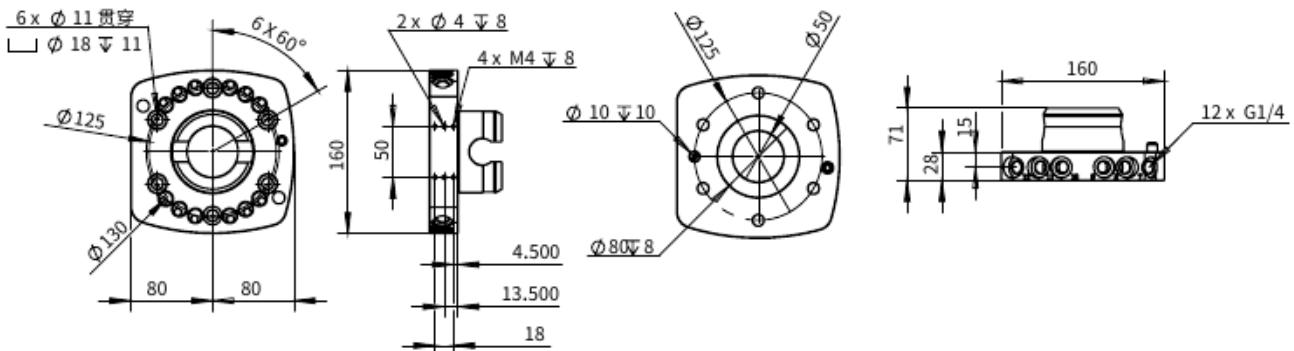

负载 (Load)	气路数量 (Number of air lines)	气路接口 (Air connection)	机器人侧连接法兰 (Robot side connection flange)	重复定位精度mm (Repeat Positioning Accuracy)	贴合后尺寸mm (Dimensions after lamination)
58kg	12	G1/4	ISO 9409-1-125-6-M10	0.02	78

#### 手动快换系统:

闭合手柄即可通过一个锁定轴锁定,快换机器人侧和工具侧之间无间隙,无需使用任何其他工具。打开手柄即可解锁系统,从而拆下快换工具侧。可以通过集成气路向末端执行器供给压缩空气或抽真空。

#### Manual quick-change system:

By closing the handle, the system is locked by a locking axis and there is no gap between the quick-change robot side and the tool side, without the need to use any other tool. The system is unlocked by opening the handle. The quick-change tool side can be removed. Compressed air or vacuum can be supplied to the end-effector by means of an integrated pneumatic circuit.

# 方形手动快换

## Square Manual Quick Changer

Profile、SUS Tube  
型材、钢管

Stents Module  
支架模组

Quick Changer  
快换

Grip Module  
夹具组件

Air Nipper  
气动剪刀

Vacuum Module  
真空组件

Accessory Components  
附件



QCS-R60

QCS-G60

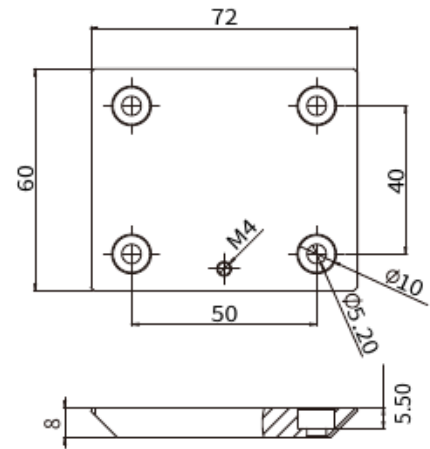
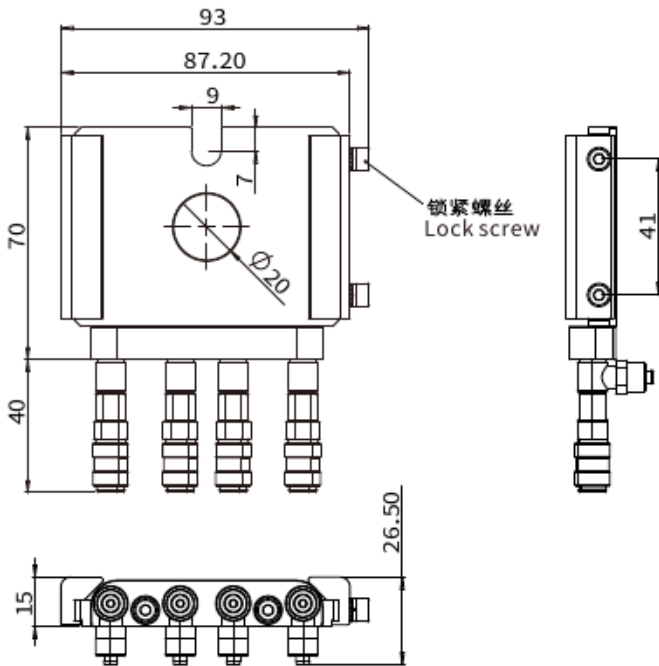

气管接头模组(选配)  
Threaded Hose Module(Optional)

货号(PN)	8.Y00081	8.Y00082	1.Y03525	1.Y03524
型号(Model)	QCS-R60	QCS-G60	KCH04-M5	KCH06-M5
负载(Load)	70N		-	-
重量/Weight	148g	79g	7g	9g

# 方形手动快换

## Square Manual Quick Changer



### QCS-R100

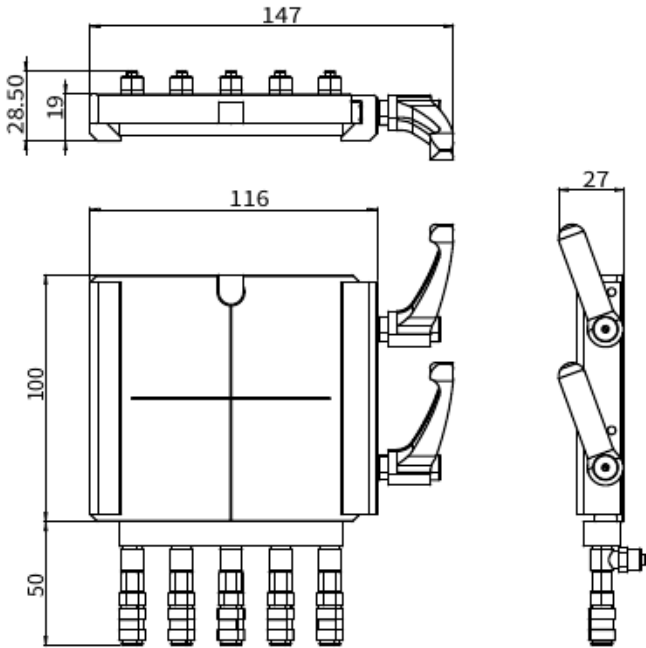

### QCS-G100

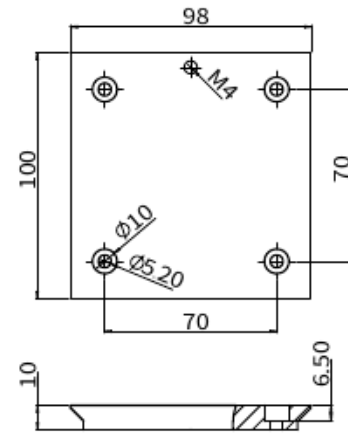

气管接头模组(选配)  
Threaded Hose Module(Optional)

货号(PN)	7.Y00332	7.Y00175	7.Y00860	7.Y00861	7.Y00334	1.Y04667
型号(Model)	QCS-R100	QCS-G100	KCH04-M5*5	KCH06-M5*5	MS-10SF*5	MS-10PF
负载(Load)	300N		-	-	-	-
重量/Weight	463g	240g	86g	96g	196g	11g

型材、钢管  
Profile、SUS Tube

支架模组  
Stents Module

快换  
Quick Changer

夹具组件  
Grip Module

气动剪刀  
Air Nipper

真空组件  
Vacuum Module

附件  
Accessory Components

# 方形手动快换

## Square Manual Quick Changer



QCS-R160

QCS-G160

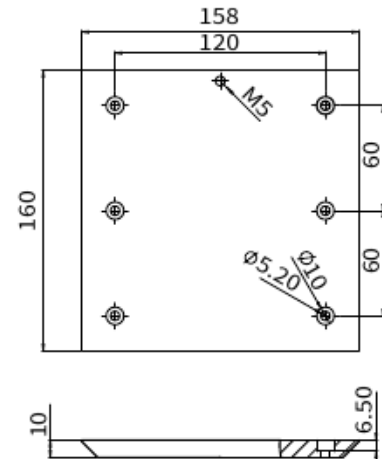
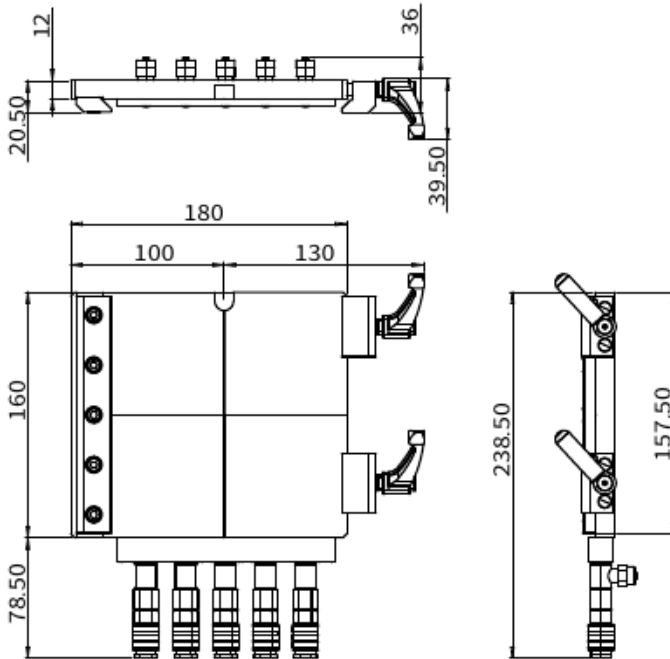

气管接头模组(选配)

Threaded Hose Module(Optional)

货号(PN)	7.Y00160	7.Y00161	7.Y02016	7.Y02017	7.Y02018	1.Y20004
型号(Model)	QCS-R160	QCS-G160	KCH104-M5*5	KCH106-M5*5	MS1-10SF*5	MS1-10PF
负载(Load)	800N		-	-	-	-
重量/Weight	1198g	634g	86g	96g	196g	11g

Profile、SUS Tube  
型材、钢管

Stents Module  
支架模组

Quick Changer  
快换

Grip Module  
夹具组件

Air Nipper  
气动剪刀

Vacuum Module  
真空组件

Accessory Components  
附件

# L形手动快换

## L-Type Manual Quick Changer



- ※超硬铝制
- ※重量: 185g
- ※安装位置: 机械手侧
- ※可搬重量: ~15kg
- ※Superhard aluminum
- ※Weight: 185g
- ※Installation location: Robot side
- ※Load weight: ~15kg

货号(PN)	1.Y01275
型号(Model)	QCL15R-Y

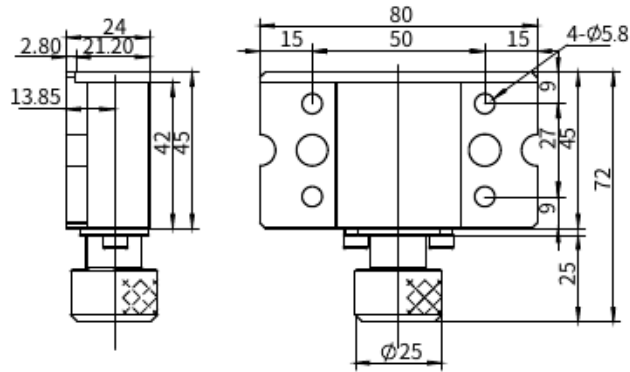

- ※钢制
- ※重量: 294g
- ※安装位置: 夹具侧
- ※可搬重量: ~15kg
- ※Steel
- ※Weight: 294g
- ※Installation location: Grip side
- ※Load weight: ~15kg

货号(PN)	1.Y01276
型号(Model)	QCL15G-Y

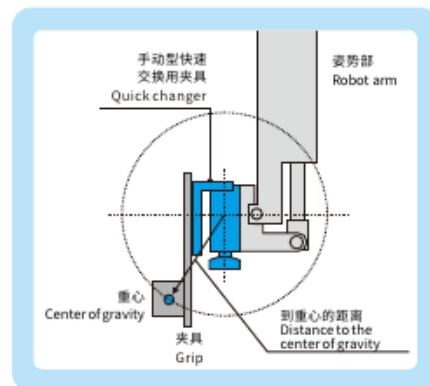
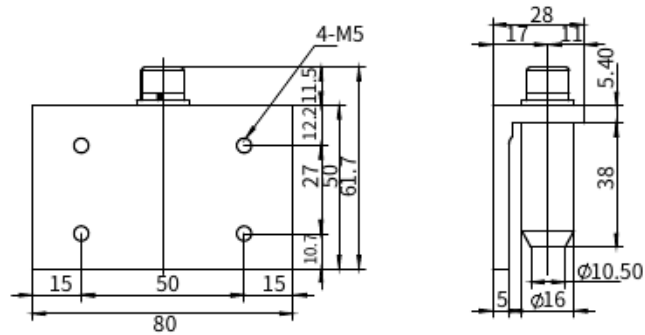

Profile- SUS Tube  
型材、钢管

Stents Module  
支架模组

Quick Changer  
快换

Grip Module  
夹具组件

Air Nipper  
气动剪刀

Vacuum Module  
真空组件

Accessory Components  
附件

# L形手动快换

## L-Type Manual Quick Changer

Profile, SUS Tube  
型材、钢管

Stents Module  
支架模组

Quick Changer  
快换

Grip Module  
夹具组件

Air Nipper  
气动剪刀

Vacuum Module  
真空组件

Accessory Components  
附件



- ※超硬铝制
- ※重量: 190g
- ※安装位置: 机械手侧
- ※可搬重量: ~15kg
- ※Superhard aluminum
- ※Weight: 190g
- ※Installation location: Robot side
- ※Load weight: ~15kg

货号 (PN)	8.Y00236
型号 (Model)	QCL15R-S

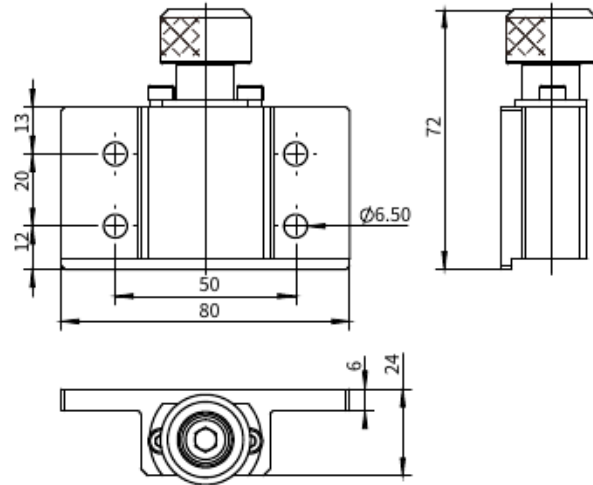

- ※超硬铝制
- ※重量: 197g
- ※安装位置: 夹具侧
- ※可搬重量: ~15kg
- ※Superhard aluminum
- ※Weight: 197g
- ※Installation location: Grip side
- ※Load weight: ~15kg

货号 (PN)	8.Y00235
型号 (Model)	QCL15G-S

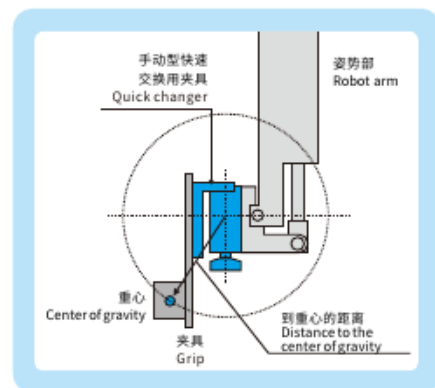
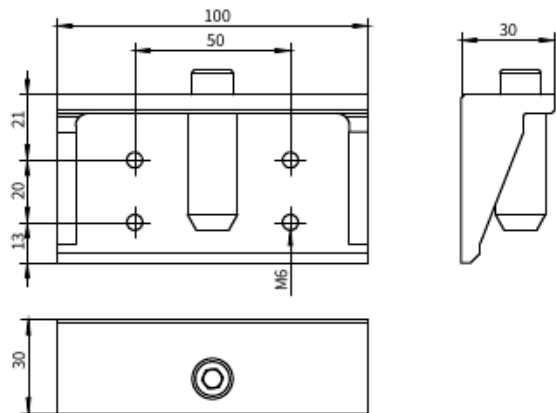

# L形手动快换

## L-Type Manual Quick Changer



- ※超硬铝制
- ※重量: 505g
- ※安装位置: 机械手侧
- ※可搬重量: ~35kg
- ※Superhard aluminum
- ※Weight: 505g
- ※Installation location: Robot side
- ※Load weight: ~35kg

货号(PN)	8.Y00101
型号(Model)	QCL35R-S

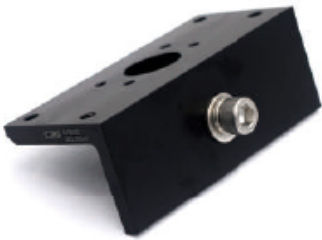
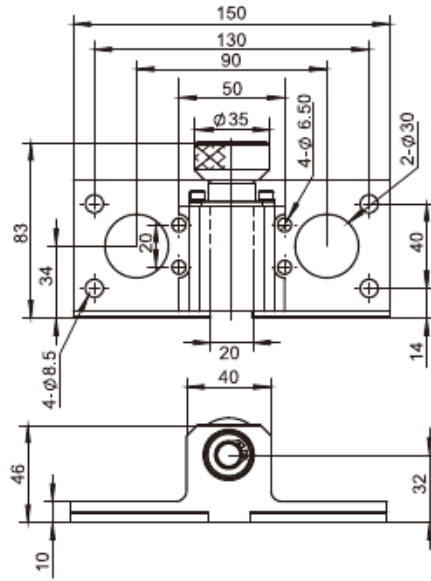

- ※超硬铝制
- ※重量: 565g
- ※安装位置: 夹具侧
- ※可搬重量: ~35kg
- ※Superhard aluminum
- ※Weight: 565g
- ※Installation location: Grip side
- ※Load weight: ~35kg

货号(PN)	8.Y00102
型号(Model)	QCL35G-S

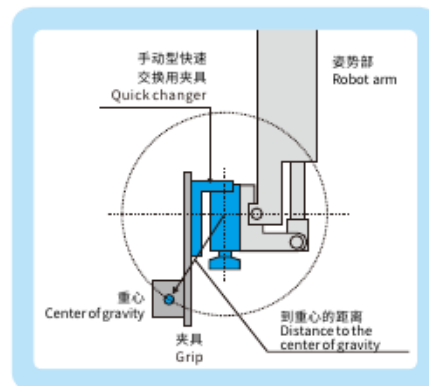
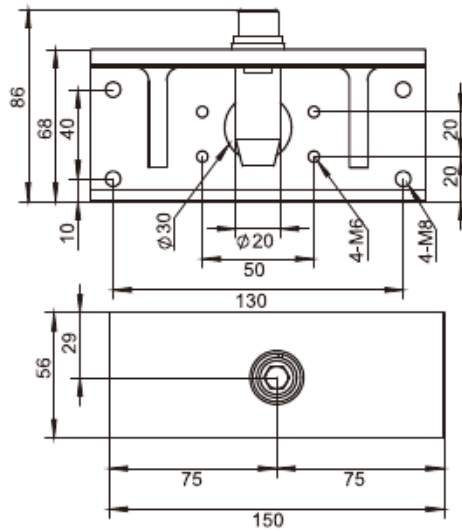

# 手动快速转换模块

## Manual Quick Changer Module

Profile、SUS Tube  
型材、钢管

Stents Module  
支架模组

Quick Changer  
快换

Grip Module  
夹具组件

Air Nipper  
气动剪刀

Vacuum Module  
真空组件

Accessory Components  
附件



- \* 铁制品
- \* 重量: 234g
- \* 安装位置: 夹具侧
- \* Iron products
- \* Weight: 234g
- \* Installation location: Grip side

货号(PN)	4.Y00480
型号(Model)	BP90

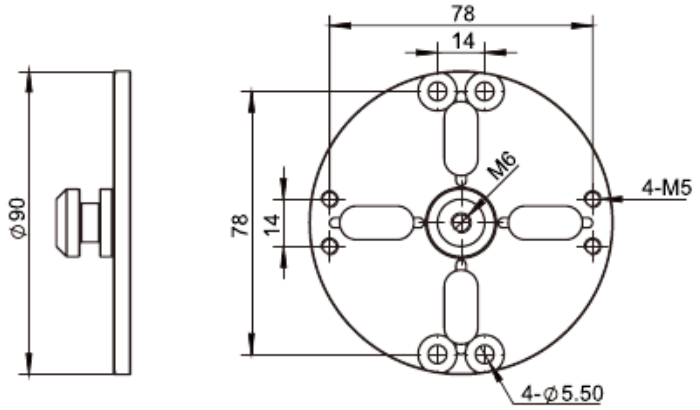

- \* 铁制品
- \* 重量: 660g
- \* 安装位置: 夹具侧
- \* Iron products
- \* Weight: 660g
- \* Installation location: Grip side

货号(PN)	4.Y00497
型号(Model)	BP135

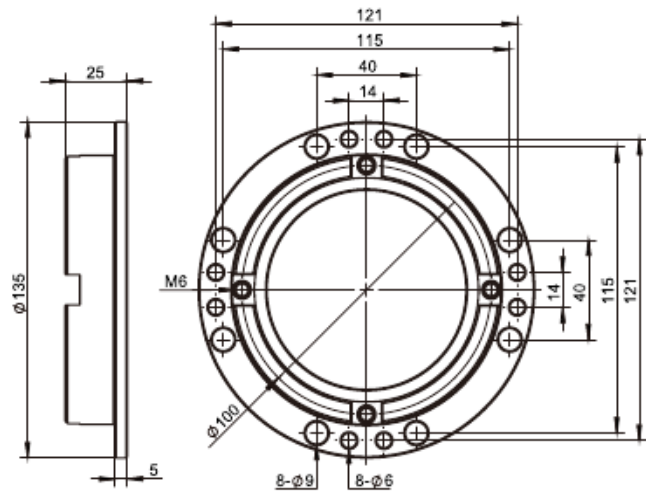

# 方形自动快换

## Square Automatic Quick Changer



- ※安装位置: 机械手侧
- ※重量: 466g
- ※可搬重量: ~10kg
- ※Installation location: Robot side
- ※Weight: 466g
- ※Load weight: ~10kg

货号(PN)	8.Y00037
型号(Model)	QCA-S10R

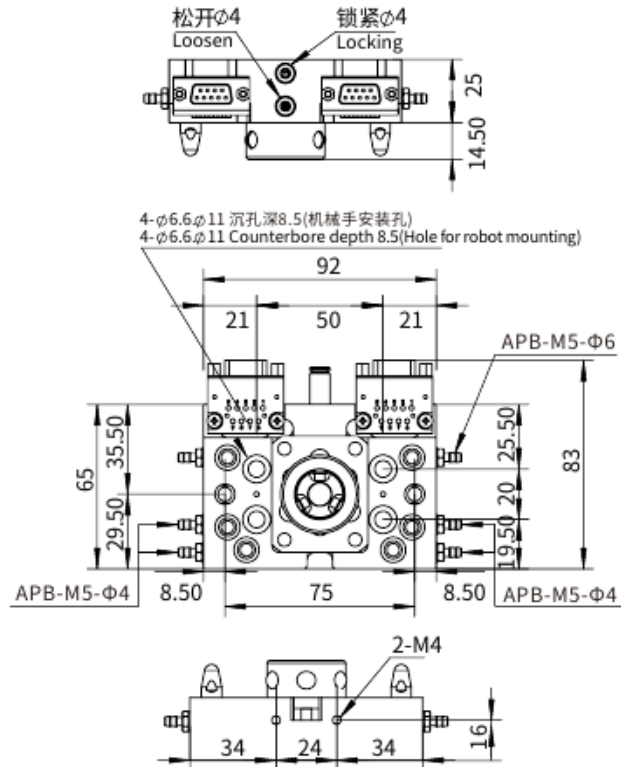

- ※安装位置: 夹具侧
- ※重量: 230g
- ※可搬重量: ~10kg
- ※Installation location: Gripper side
- ※Weight: 230g
- ※Load weight: ~10kg

货号(PN)	8.Y00038
型号(Model)	QCA-S10G

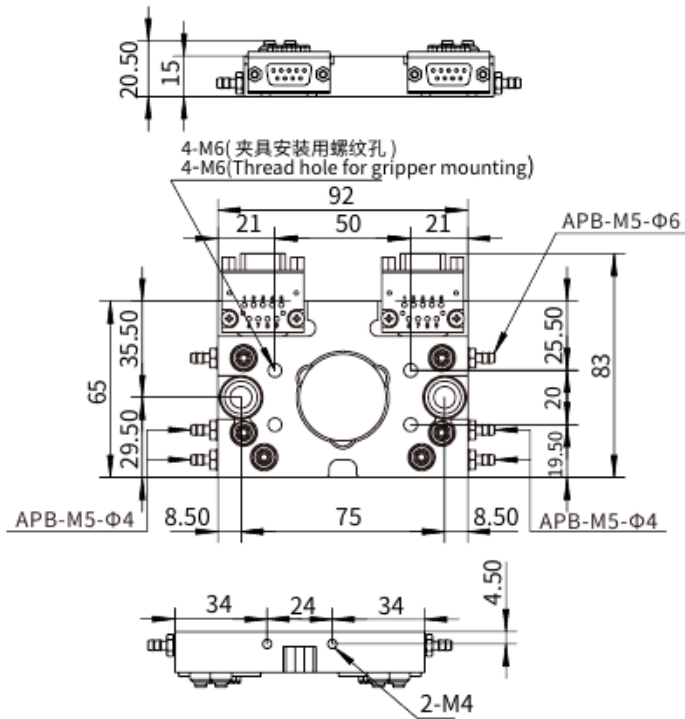

Profile、SUS Tube

Stents Module

Quick Changer

Gripper Module

Air Nipper

Vacuum Module

Accessory Components

# 自动快换 Quick Changer

## QCA-20



机器人侧  
Robot side



夹具侧  
Gripper side

货号(PN)	8.Y01093
型号(Model)	QCA-20R

货号(PN)	8.Y01094
型号(Model)	QCA-20G

### 机器人侧 Robot side

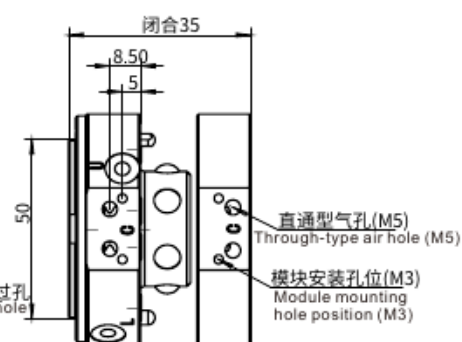
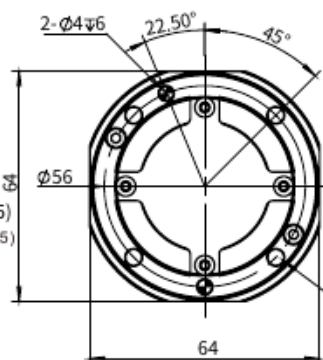
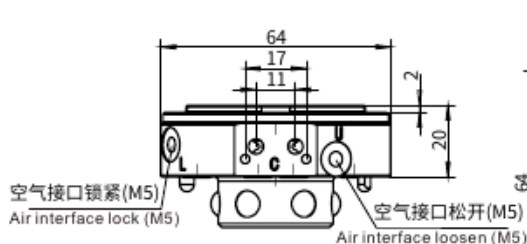

### 夹具侧 Gripper side

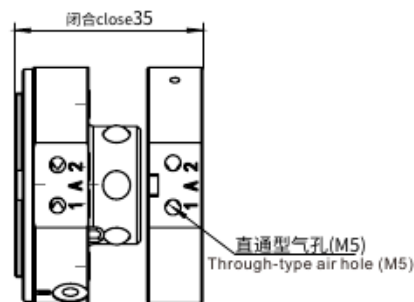
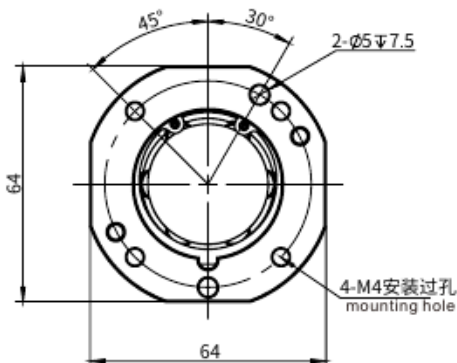
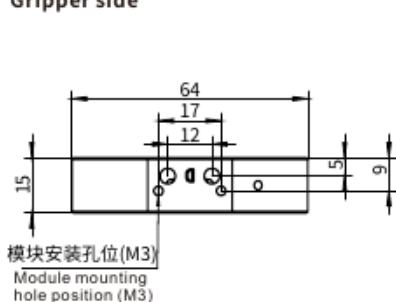

### 产品参数 Parameter

1. 负载: 20kg
2. 锁紧力: 2059N
3. 静态承载扭矩(X&Y): 56.8Nm
4. 静态承载扭矩(Z): 78.4Nm
5. 重复精度 ±0.015
6. 机器人侧重量: 224g
7. 治具侧重量: 114g
8. 直通型气孔尺寸: 8-(M5)

1. Load: 20kg
2. Locking force: 2059N
3. Static Load torque (X&Y): 56.8Nm
4. Static Load torque (Z): 78.4Nm
5. Repeatability ±0.015
6. Robot side's weight: 224g
7. Gripper side's weight: 114g
8. Size of straight air hole (quantity): 8-(M5)

# 信号模块

Signal Module

## QCHFM-02R1-1000

机器人侧模块  
Robot side module



货号(PN)	7.Y02261
型号(Model)	QCHFM-02R1-1000

- ※ 电压Voltage: 1.4KV
- ※ 电流Current: 5A
- ※ 重量Weight: 85g
- ※ 适配于 Suitable for: QCA-20

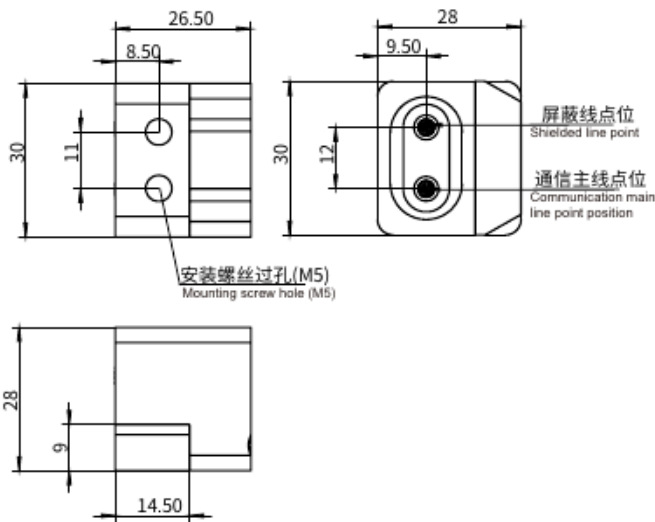

## QCHFM-02G1-1000

夹具侧模块  
Gripper side module



货号(PN)	7.Y02262
型号(Model)	QCHFM-02G1-1000

- ※ 电压Voltage: 1.4KV
- ※ 电流Current: 5A
- ※ 重量Weight: 75g

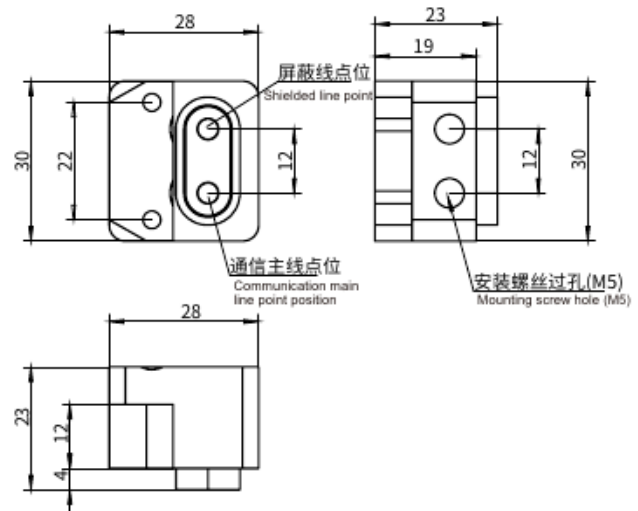

Profile、SUS Tube

Stents Module

Quick Changer

Grip Module

Air Nipper

Vacuum Module

Accessory Components

# 信号模块

## Signal Module

### QCSM-08R2-1000

机器人侧模块  
Robot side module



货号(PN)	7.Y02127
型号(Model)	QCSM-08R2-1000

- ※ 电压Voltage: 24V
- ※ 电流Current: 2.5A
- ※ 重量Weight: 71g
- ※ 适配于 Suitable for: QCA-20

### QCSM-08G2-1000

夹具侧模块  
Gripper side module



货号(PN)	7.Y02128
型号(Model)	QCSM-08G2-1000

- ※ 电压Voltage: 24V
- ※ 电流Current: 2.5A
- ※ 重量Weight: 69g

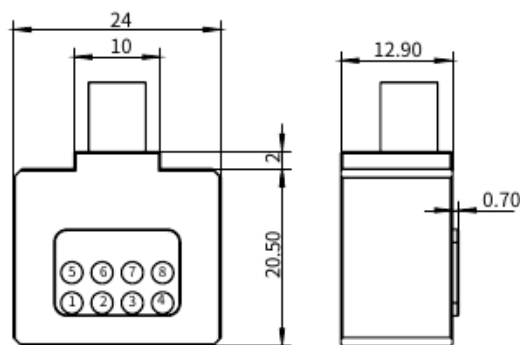
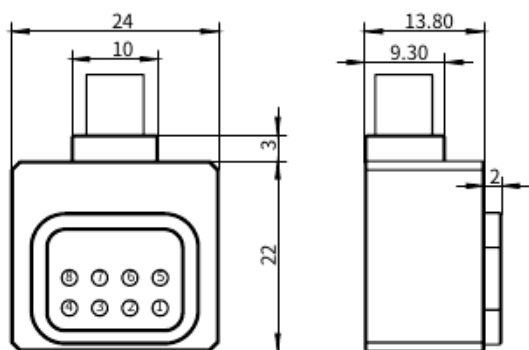

## 接线图/Wiring Diagram

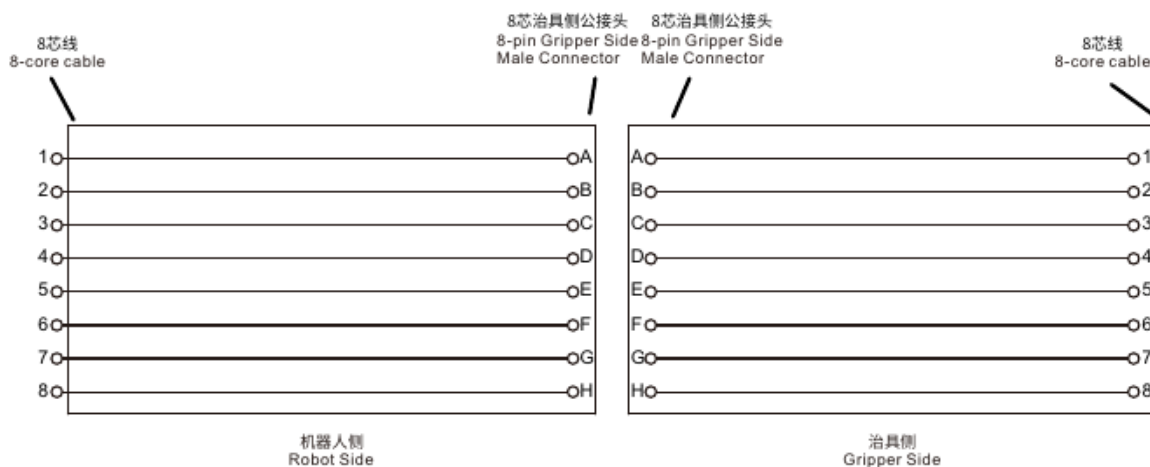

Profile, SUS Tube  
型材、钢管

Stents Module  
支架模组

Quick Changer  
快换

Grip Module  
夹具组件

Air Nipper  
气动剪刀

Vacuum Module  
真空组件

Accessory Components  
附件

# 自动快换

Quick Changer

## QCA-130



机器人侧  
Robot side

货号(PN)	8.Y01230
型号(Model)	QCA-130R-K4N032682

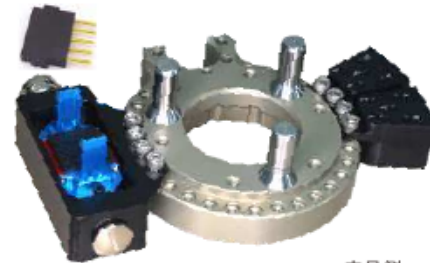

夹具侧  
Gripper side

货号(PN)	8.Y01229
型号(Model)	QCA-130G-K4N032684

- ※ QCSM-CP-25R/G信号模块, 共有5个模块, 一个模块有5极(即可接入5根针), 可根据需求改变针的数量(1-25根)。  
QCSM-CP-25R/G signaling module, there are 5 modules, one module has 5 poles (i.e. can access 5 pins), the number of pins can be changed according to the demand (1-25 pins).
- ※ 电压Voltage: 220V
- ※ 电流Current: 10A
- ※ 工作温度Working temperature: -40°C~90°C

### 机器人侧 Robot side

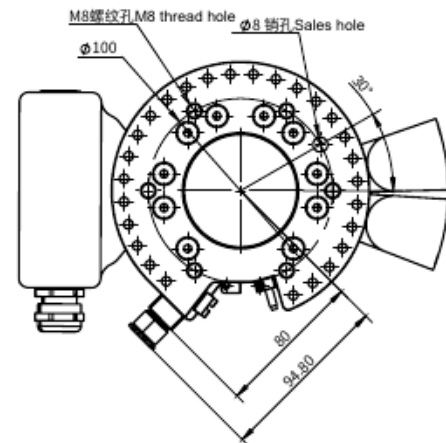
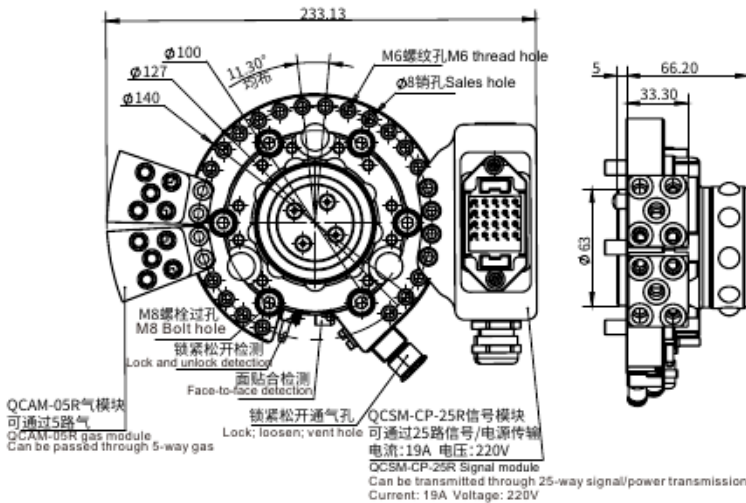

### 夹具侧 Gripper side

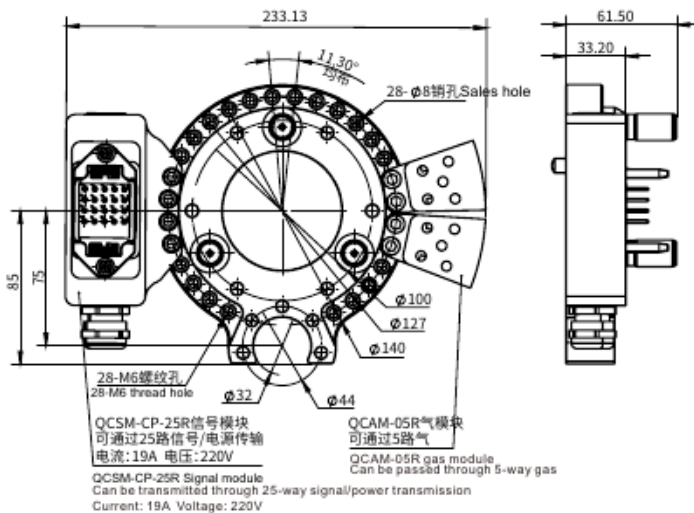

Profile- SUS Tube  
型材、钢管

Stents Module  
支架模组

Quick Changer  
快换

Grip Module  
夹具组件

Air Nipper  
气动剪刀

Vacuum Module  
真空组件

Accessory Components  
附件

# 补偿单元

## Compensation Unit

功能: 在自动化任务中提供完美的补偿, 在 XY 和 Z 向搬运时, 采用压缩空气锁定可使装置牢固, 采用 XY 方向位置存储器可偏心固定。  
 Function: Perfect compensation in automation tasks, compressed air locking for a secure unit during XY and Z handling, eccentric fixation with position memory in XY direction.

应用领域: 堆垛、接合和装配  
 Areas of application: stacking, joining and assembly

产品优点: ISO 安装方式, 无需其他转接板便于装配到大部分机器人型号上一个单元实现三个补偿方向, 紧凑设计  
 Advantages: ISO mounting, no additional adapter plates required for easy assembly to most robot models Three compensation directions in one unit, compact design

Profile, SUS Tube  
 型材

Stents Module  
 支架模组

Quick Changer  
 快换

Grip Module  
 夹具组件

Air Nipper  
 气动剪刀

Vacuum Module  
 真空组件

Accessory Components  
 附件



货号(PN)	8.Y01235
型号(Model)	OFU-XYZ100
重量(Weight)	3.6kg

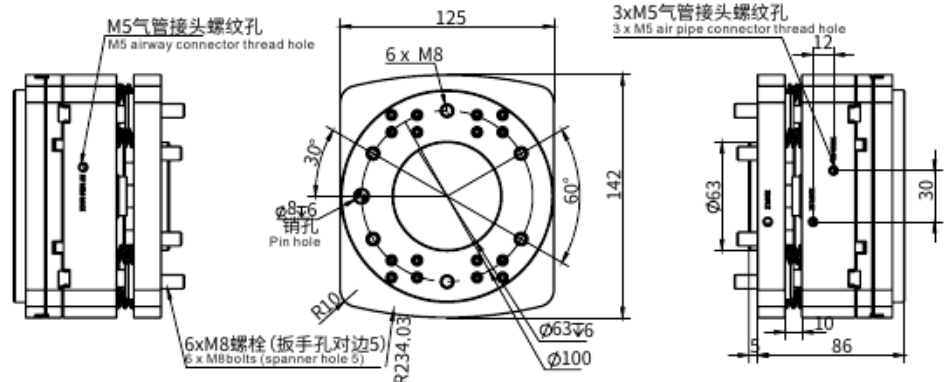

货号(PN)	8.Y01236
型号(Model)	OFU-XYZ125
重量(Weight)	7.3kg

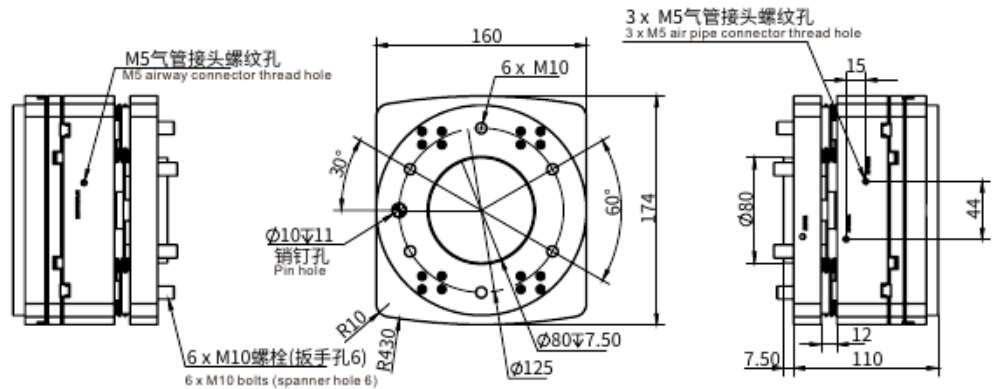

货号(PN)	8.Y01260
型号(Model)	OFU-XYZ160
重量(Weight)	14.5kg

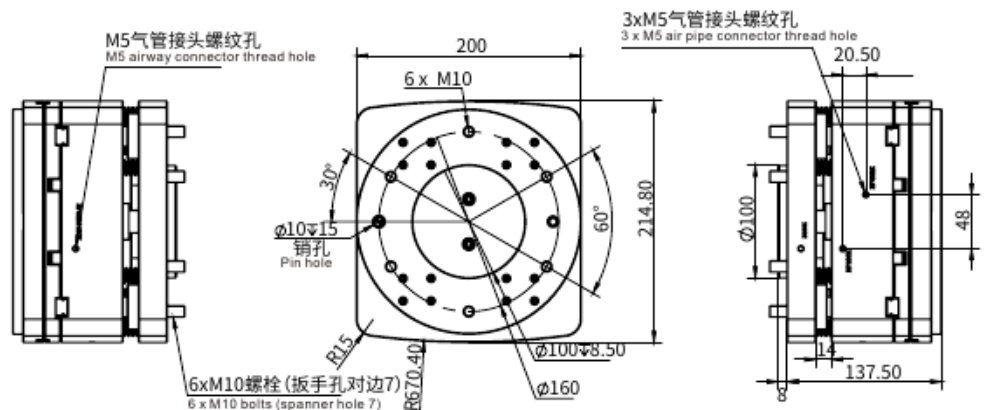

NEW

# 补偿单元

## Compensation Unit

货号 NP	8.Y01235	8.Y01236	8.Y01260
型号 Model	OFU-XYZ100	OFU-XYZ125	OFU-XYZ160
XY 补偿 XY Compensation	±4mm	±7mm	±10mm
Z 向补偿 Z Compensation	10mm	12mm	14mm
建议搬运重量,垂直 Recommended lifting weight, vertical	9KG	18KG	60KG
建议搬运重量,水平 Recommended lifting weight, horizontal	5.5KG	11KG	40KG
锁紧力 Locking force	800N	1100N	1800N
位置存储活塞力 Position storage piston force	1100N	1700N	2900N
最大径向力位置存储 Maximum radial force position storage	126N	198N	309N
行程 Z Stroke Z	800N	1200N	1900N
最小弹簧力 Minimum spring force	240N	360N	640N
最小/额定/最大工作压力 Minimum/rated/maximum working pressure	2.5/6/8bar	2.5/6/8bar	2.5/6/8bar
重复精度 Repeatability	0.1mm	0.1mm	0.1mm
机器人侧连接 Robot side connection	ISO 9409-1-100-6-M8	ISO 9409-1-125-6-M10	ISO 9409-1-160-6-M10
工具侧连接 Tool Side Connection	ISO 9409-1-100-6-M8	ISO 9409-1-125-6-M10	ISO 9409-1-160-6-M10
重量 Weight	3.6KG	7.4KG	14.5KG
最低/最高环境温度 Min/Max Ambient Temperature	5/60°C	5/60°C	5/60°C
尺寸X*Y*Z Dimension X*Y*Z	142*125*86mm	175*160*110mm	215*200*137mm

### 适用产品

#### Drawings

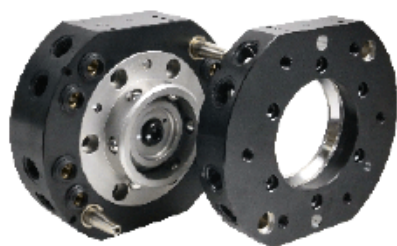

快换系列  
Quick changer series

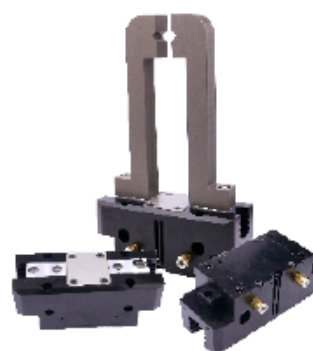

平动式抓手系列  
Flat-action gripper series

型材、钢管  
Profile, SUStube

支架模组  
Stents Module

快换  
Quick Changer

夹具组件  
Grip Module

气动剪刀  
Air Nipper

真空组件  
Vacuum Module

附件  
Accessory Components

## 两指平动式抓手

### Two-finger Translational Gripper

- 采用多齿导轨，具有较大的抓取力和较高的最大力矩
- 磁性开关接口
- 接近开关接口
- 无管连接接口
- 一千万次免维护操作
- Features a multi-tooth guide rail, providing high gripping force and high maximum torque
- Magnetic switch interface
- Proximity switch interface
- Pipeless connection interface
- Ten million maintenance-free operations



基础款  
Basic Style



抓取力保持款  
Grip-Retaining Style

#### 定义:

两指平动式抓手采用双指结构，在抓取过程中两指始终保持平行运动，通过相向或反向的直线移动来实现对工件的夹持与释放。

#### Definition:

The two-finger parallel motion gripper employs a dual-finger structure, maintaining constant parallel movement throughout the grasping process. It achieves workpiece clamping and release through linear motion in either parallel or opposite directions.

#### 核心特点:

- **运动方式:** 纯平移运动，无转动成分，轨迹简单可控。
- **夹持稳定性:** 由于夹持面始终保持平行，特别适用于夹持具有平行平面的工件（如方块、板状零件），可提供均匀的夹持力分布。
- **精度与控制:** 运动路径一致性强，易于实现高重复定位精度，适用于需精确对位或插装的应用。

#### Core Features:

- **Motion Type:** Pure translational motion with no rotational components, ensuring simple and controllable trajectories.
- **Clamping Stability:** The clamping surfaces remain parallel at all times, making it ideal for holding workpieces with parallel lanes (e.g., cubes, plate-like components). It provides uniform clamping force distribution.
- **Precision and Control:** The highly consistent motion path facilitates high repeatability and positioning accuracy, making it suitable for applications requiring precise alignment or insertion.

# FPT两指平动式抓手

## FPT Two-finger Translational Gripper

型号 NP	货号 Model	单指行程 (mm) Single-finger stroke	最长手指 长度 (mm) Longest finger length	闭合力 (N) Closing force	张开力 (N) Opening force	建议工件 重量 (kg) Recommended workpiece weight	最小 保持力 (N) Minimum holding force	耗气量 [双程] (cm <sup>3</sup> ) Air consumption [two-stroke]	最小工作 压力 (bar) Minimum working pressure	最大工作 压力 (bar) Maximum working pressure	自重(g) Weight
FPT-40B-1	8.Y01324	2.5	65	180	200	0.9	/	4	4	8	78g
FPT-40B-1-S	8.Y01325	2.5	60	235	260	0.9	55	8	3	6.5	101g
FPT-50B-1	8.Y01326	4	80	220	235	1.1	/	6	4	8	151g
FPT-50B-1-S	8.Y01327	4	75	295	330	1.1	75	10	3	6.5	209g
FPT-64B-1	8.Y01328	6	100	350	375	1.75	/	15	4	8	271g
FPT-64B-1-S	8.Y01329	6	90	470	500	1.75	120	24	3	6.5	366g
FPT-80B-1	8.Y01330	8	125	550	610	3	/	30	4	8	470g
FPT-80B-1-S	8.Y01331	8	115	760	830	3	190	45	3	6.5	231g
FPT-100B-1	8.Y01332	10	160	900	930	4.5	/	55	4	8	821g
FPT-100B-1-S	8.Y01333	10	145	1200	1300	4.5	370	84	3	6.5	1073g
FPT-125B-1	8.Y01334	13	200	1400	1520	<7	/	120	4	8	1400g
FPT-125B-1-S	8.Y01335	13	185	2000	2150	<7	600	160	3	6.5	1857g
FPT-160B-1	8.Y01336	16	225	2700	2800	<12.5	/	200	4	8	2553g
FPT-160B-1-S	8.Y01337	16	225	3300	3550	<12.5	700	360	3	6.5	3556g
FPT-200B-1	8.Y01338	25	310	3800	4050	<19	/	510	4	8	5150g
FPT-240B-1	8.Y01339	30	355	5300	5600	<26.5	/	900	4	8	7800g

\*重复精度 Repeatability:0.01(mm)\*额定工作压力 Rated Working Pressure:6(bar)

\*型号-S为抓取力保持款Model-S: Gripping Force Retention Version

### 可选附件

#### Optional accessories

产品图 Product image	货号 (PN)	产品型号 Product Model	描述 Description
 磁性开关 M8 Magnetic switch M8	1.Y00307	D-M9BL	线长3m, 末端裸露线 Wire length is 3m, the end is bare
 90°弯角 可旋转气管接头 90° bend angle Rotatable Hose Fitting	1.Y13156	KQ2V06-01AS	90度弯头, G1/8螺纹接头, 6mm气管接头输出 90 degree elbow, G1/8 threaded connector, 6mm Hose Fitting output
	1.Y13159	KQ2V08-01AS	90度弯头, G1/8螺纹接头, 8mm气管接头输出 90 degree elbow, G1/8 threaded connector, 8mm Hose Fitting output
	1.Y13157	KQ2V06-02AS	90度弯头, G1/4螺纹接头, 6mm气管接头输出 90 degree elbow, G1/4 threaded connector, 6mm Hose Fitting output

Profile- SUS Tube  
型材、钢管

Stents Module  
支架模组

Quick Changer  
快换

Grip Module  
夹具组件

Air Nipper  
气动剪刀

Vacuum Module  
真空组件

Accessory Components  
附件

## 三指平动式抓手

### Three-finger Translational Gripper

- 采用多齿导轨, 具有较大的抓取力和较高的最大力矩
- 磁性开关接口
- 接近开关接口
- 无管连接接口
- 一千万次免维护操作
- Features a multi-tooth guide rail, providing high gripping force and high maximum torque
- Magnetic switch interface
- Proximity switch interface
- Pipeless connection interface
- Ten million maintenance-free operations



#### 定义:

三指定心式抓手通常配置三根(或更多)手指, 在抓取过程中各指同步沿抓手径向运动, 始终指向或背离执行器的中心轴线, 从而实现工件的中心定位与包络抓取。

#### Definition:

Tri-designated centering claws typically feature three (or more) fingers that move synchronously along the claw's radial axis during gripping. Each finger consistently points toward or away from the actuator's central axis, enabling both workpiece centering and enveloping gripping.

#### 核心特点:

- **自动对中功能:** 无论工件尺寸在夹持范围内如何变化, 手指运动始终保持工件位于抓手中心, 适用于需要同心定位的场合。
- **夹持包容性:** 多指结构可适配圆柱形、球状及不规则回转体工件, 提供均匀的径向夹持力, 避免局部应力过大。
- **无损抓取:** 适合夹持易损或精密表面工件, 如光学镜片、精密轴类零件等。

#### Core Features:

- **Automatic centering function:** Regardless of how the workpiece dimensions vary within the clamping range, the finger movement consistently maintains the workpiece at the center of the gripper jaws, suitable for applications requiring concentric positioning.
- **Versatile Gripping:** The multi-finger structure accommodates cylindrical, spherical, and irregularly shaped rotating workpieces, delivering uniform radial clamping force to prevent localized stress concentration.
- **Non-Destructive Handling:** Ideal for gripping fragile or precision-surfaced components such as optical lenses and precision shaft parts.

# FCT三指平动式抓手

## FCT Three-finger Translational Gripper

型号 NP	货号 Model	单指行程 (mm) Single-finger stroke	最长手指 长度 (mm) Longest finger length	闭合力 (N) Closing force	张开力 (N) Opening force	建议工件 重量 (kg) Recommended workpiece weight	最小 保持力 (N) Minimum holding force	耗气量 [双程] (cm <sup>3</sup> ) Air consumption [two-stroke]	最小工作 压力 (bar) Minimum working pressure	最大工作 压力 (bar) Maximum working pressure	自重(g) Weight
FCT-40B-1	8.Y01340	2.5	50	255	270	<1.3	/	5	4	8	116g
FCT-50B-1	8.Y01341	4	70	325	350	<1.65	/	9	4	8	228g
FCT-64B-1	8.Y01342	6	90	580	600	<2.9	/	25	4	8	380g
FCT-80B-1	8.Y01343	8	110	1000	1100	<5	/	60	4	8	710g
FCT-100B-1	8.Y01344	10	145	1800	1900	<9	/	120	4	8	1261g
FCT-125B-1	8.Y01345	13	180	3000	3200	<15	/	230	4	8	2308g
FCT-160B-1	8.Y01346	16	220	6000	6300	<30	/	520	4	8	4684g
FCT-200B-1	8.Y01347	25	280	7000	7400	<35	/	1040	4	8	10200g
FCT-240B-1	8.Y01348	30	300	9000	9500	<50	/	1780	4	8	16100g

\*重复精度 Repeatability:0.01(mm)\*额定工作压力 Rated Working Pressure:6(bar)

### 可选附件

#### Optional accessories

产品图 Product image	货号 (PN)	产品型号 Product Model	描述 Description
 磁性开关 M8 Magnetic switch M8	1.Y00307	D-M9BL	线长3m, 末端裸露线 Wire length is 3m, the end is bare
 90°弯角 可旋转气管接头 90° bend angle Rotatable Hose Fitting	1.Y13156	KQ2V06-01AS	90度弯头, G1/8螺纹接头, 6mm气管接头输出 90 degree elbow, G1/8 threaded connector, 6mm Hose Fitting output
	1.Y13159	KQ2V08-01AS	90度弯头, G1/8螺纹接头, 8mm气管接头输出 90 degree elbow, G1/8 threaded connector, 8mm Hose Fitting output
	1.Y13157	KQ2V06-02AS	90度弯头, G1/4螺纹接头, 6mm气管接头输出 90 degree elbow, G1/4 threaded connector, 6mm Hose Fitting output

Profile- SUS Tube  
型材、钢管

Stents Module  
支架模组

Quick Changer  
快换

Grip Module  
夹具组件

Air Nipper  
气动剪刀

Vacuum Module  
真空组件

Accessory Components  
附件

# Y型夹

## Y Type Gripper

Profile, SUS Tube  
型材、钢管

Stents Module  
支架模组

Quick Changer  
快换

Grip Module  
夹具组件

Air Nipper  
气动剪刀

Vacuum Module  
真空组件

Accessory Components  
附件

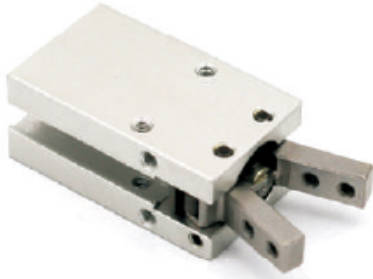

### 型号表示方法

#### Model representation methods

[标准型]  
Standard type

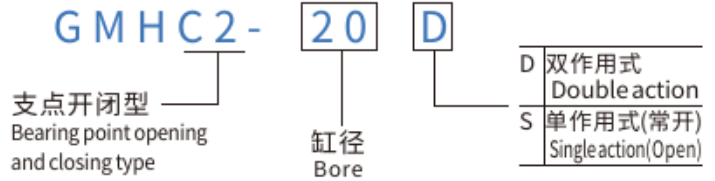

货号 PN	型号 Model	缸径 Bore	压力范围(c.p.m) Pressure Range		温度范围 Temperature range	重复精度 Repetition accuracy	最高使用频率 (c.p.m) Maximum frequency of use	接管口径 Nozzle diameter	重量 Weight
			单作用 Single Action	双作用 Double action					
1.Y02014	GMHC2-16S	16	0.1~0.6	/	-10~60°C	±0.01	180	M5*0.8	99g
1.Y05738	GMHC2-16D	16	/	0.25~0.6	-10~60°C	±0.01	180	M5*0.8	108g
1.Y02730	GMHC2-20S	20	0.1~0.6	/	-10~60°C	±0.01	180	M5*0.8	167g
1.Y04328	GMHC2-20D	20	/	0.25~0.6	-10~60°C	±0.01	180	M5*0.8	177g

备注:  
1.采用空气流体  
2.动作方式单作用双作用(可选)

Notes:  
1, Air Fluid  
2, action mode single-acting double-acting (optional)

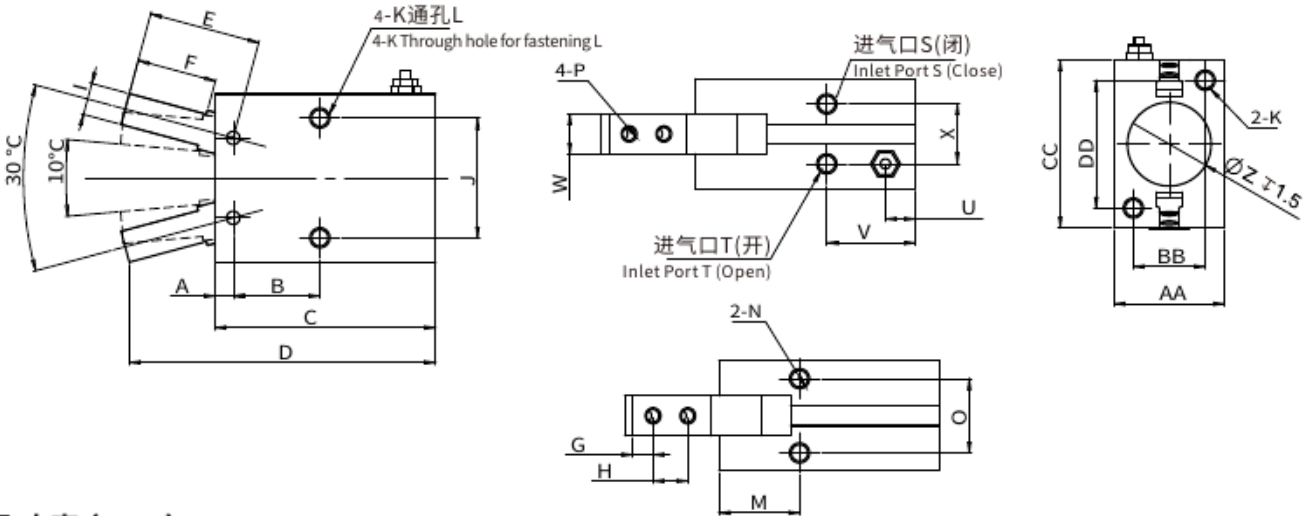

### 尺寸表 (mm)

#### Dimensions table

缸径 (Bore) (mm)	A	B	C	D	E	F	G	H	I	J	K	L	M	N	O	P	接管口径 Pipe Size		U	V	W	X	Z	AA	BB	CC	DD
																	S	T									
16	3.9	16.2	44.6	62.5	22.6	16	4	7	7	24	M4X0.7T8	3.4	10.7	M4X0.7T8	16	M3X0.5	M5X0.8	7	18.3	8	13	17	23.6	15	30.6	22	
20	4.5	21.7	55.2	78.7	28	20	5.2	9	8	30	M5X0.8T10	4.3	15.7	M5X0.8T8	8.6	M4X0.7	M5X0.8	7.5	22.2	10	15	21	27.6	18	42	32	



### 型号表示方法

Model representation methods

[标准型]

Standard type

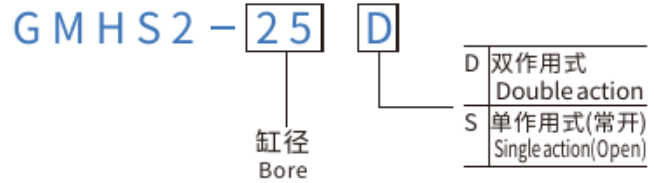

货号 PN	1.Y04529	1.Y04764	1.Y05750	
型号 Model	GMHS3-16D	GMHS3-20D	GMHS3-25D	
缸径 Bore	16	20	25	
使用流体 Fluid	空气 Air			
使用压力范围 Operating pressure range	0.2~0.6MPa			
环境及流体温度 Environment and fluid temperature	-10~60°C			
重复精度(mm) Repeatability accuracy	±0.01			
最高使用频率(c.p.m) Maximum frequency of use	120c.p.m			
动作方式 action mode	双作用 Double action			
注)夹持力N 压力0.5MPa Note) gripping force N Pressure 0.5MPa	外径夹持 External diameter clamping	14	25	42
	内径夹持 Internal diameter clamping	16	28	47
	带防尘罩外径夹持 External diameter clamping with dust cover	9	21	36
带罩·标准型手指行程 Standard finger stroke with hood	4	4	6	
长行程手指行程 Long stroke finger stroke	10	10	12	
接管口径 Rc Pipe Size	M3×0.5	M5×0.8	M5×0.8	
磁性开关 Magnetic switch	内置磁环型 Built in magnetic ring type			
重量 Weight	59g	96.7g	138g	

注)夹持外径时的夹持力, Ø16-Ø25的夹持点距离L=20mm时的数值  
Note)Clamping force when holding the outside diameter,  
The value of the holding point of Ø16-Ø25 is L=20mm

# 三爪夹

## Three Jaws Gripper

Profile, SUS Tube  
型材、钢管

Stents Module  
支架模组

Quick Changer  
快换

Grip Module  
夹具组件

Air Nipper  
气动剪刀

Vacuum Module  
真空组件

Accessory Components  
附件

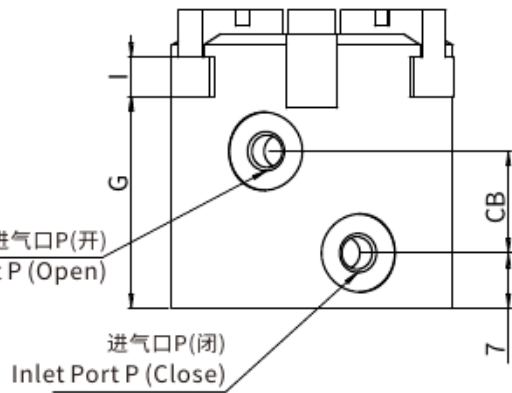
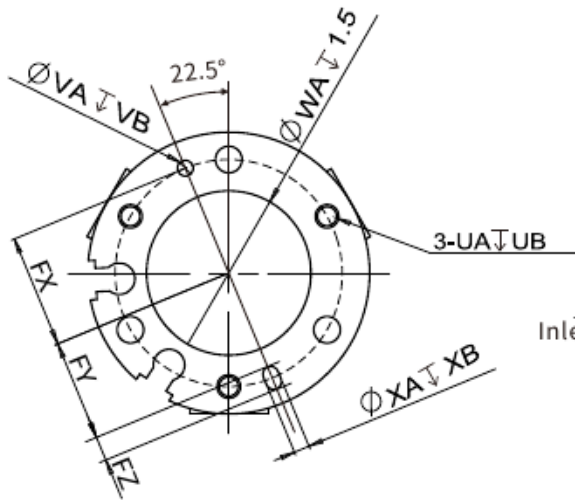
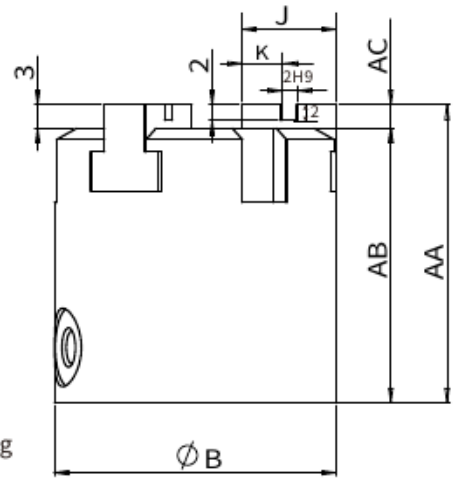
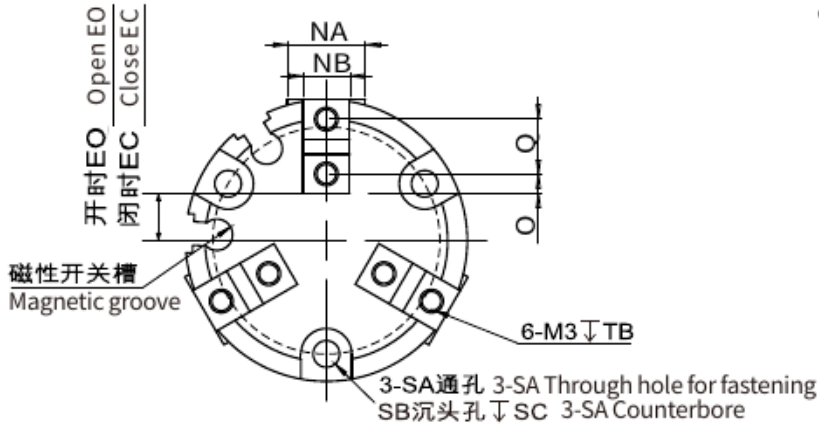

缸径(Bore)	AA	AB	B	CB	EC	EO	FX	FY	FZ	G	I	J	K	NA	NB
16	35	32	30	11	5	7	12.5	11	3	25	4	10	4	8	5h9
20	38	35	36	13	6	8	14.5	13	3	27	5	12	5	10	6h9
25	40	37	42	15	7	10	17	14.5	5	28	5	14	6	12	6h9

缸径(Bore)	O	P	Q	SA	SB	SC	TB	UA	UB	VA	VB	WA	XA	XB
16	2	M3x0.5	6	3.4	6.5	8	5	M3x0.5	4.5	2H9	2	17H9	2H9	2
20	2.5	M5x0.8	7	3.4	6.5	9.5	6	M3x0.5	6	2H9	2	21H9	2H9	2
25	3	M5x0.8	8	4.5	8	10	6	M4x0.7	6	3H9	3	26H9	3H9	3

# 平行夹

## Parallel Gripper

Profile, SUS Tube  
型材、钢管

Stents Module  
支架模组

Quick Changer  
快换

Grip Module  
夹具组件

Air Nipper  
气动剪刀

Vacuum Module  
真空组件

Accessory Components  
附件

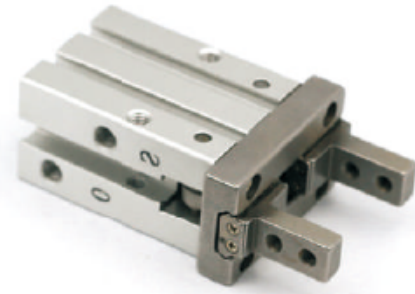

### 型号表示方法

#### Model representation methods

[标准型]  
Standard type

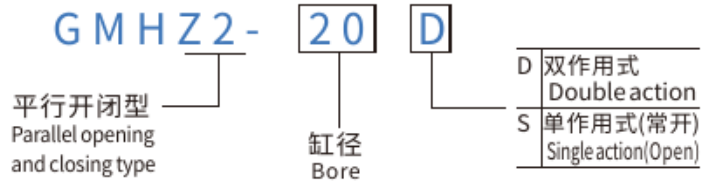

货号 PN	型号 Model	缸径 Bore	压力范围(MPa) Pressure Range		温度范围 Temperature range	重复精度 Repetition accuracy	最高使用频率 (c.p.m) Maximum frequency of use	接管口径 Nozzle diameter	重量 Weight	夹持力(N) Gripping force (N)			两侧开闭 行程 (mm) Opening and closing stroke on both sides
			单作用 Single Action	双作用 Double action						双动 Double action			
										外径 External	内径 Internal		
1.Y00258	GMHZ2-10S	10	0.35-0.7	/	-10-60°C	±0.01	180	M3*0.5	53g	7.1	11	17	4
1.Y00252	GMHZ2-10D	10	/	0.2-0.7	-10-60°C	±0.01	180	M3*0.5	52.5g	7.1	11	17	4
1.Y00257	GMHZ2-16S	16	0.25-0.7	/	-10-60°C	±0.01	180	M5*0.8	123g	27	34	45	6
1.Y00256	GMHZ2-16D	16	/	0.1-0.7	-10-60°C	±0.01	180	M5*0.8	120g	27	34	45	6
1.Y03080	GMHZ2-20S	20	0.25-0.7	/	-10-60°C	±0.01	180	M5*0.8	227g	33	42	66	10
1.Y02703	GMHZ2-20D	20	/	0.1-0.7	-10-60°C	±0.01	180	M5*0.8	225g	33	42	66	10
1.Y09884	GMHZ2-25S	25	0.25-0.7	/	-10-60°C	±0.01	180	M5*0.8	309g	45	65	104	14
1.Y09338	GMHZ2-25D	25	/	0.1-0.7	-10-60°C	±0.01	180	M5*0.8	314g	45	65	104	14
1.Y09885	GMHZ2-32S	32	0.25-0.7	/	-10-60°C	±0.02	60	M5*0.8	415g	131	158	193	22
1.Y09886	GMHZ2-32D	32	/	0.1-0.7	-10-60°C	±0.02	60	M5*0.8	410g	131	158	193	22
1.Y09887	GMHZ2-40S	40	0.25-0.7	/	-10-60°C	±0.02	60	M5*0.8	543g	217	254	318	30
1.Y09888	GMHZ2-40D	40	/	0.1-0.7	-10-60°C	±0.02	60	M5*0.8	537g	217	254	318	30

备注:

1. 采用空气流体
2. 动作方式单作用双作用(可选)
3. 可选无触点磁性开关

Notes:

1. Air Fluid
2. action mode single-acting double-acting (optional)
3. optional non-contact magnetic switch

### 尺寸表 (mm)

#### Dimensions table

GMHZ2-10□的磁性开关安装槽尺寸  
GMHZ2-10□Magnetic Switch Mounting Groove Dimensions

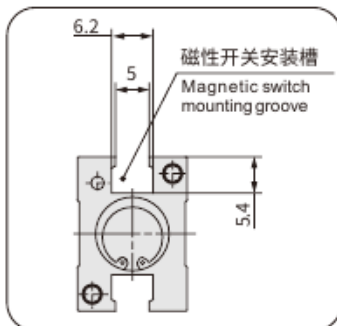

注) 使用磁性开关时, 气爪不可以通孔安装  
Note) When using Magnetic switches, through-hole mounting is not possible.

GMHZ2-□□的磁性开关安装槽尺寸  
GMHZ2-□□Magnetic Switch Mounting Groove Dimensions

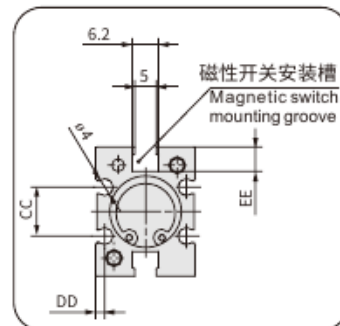

注) 使用磁性开关 D-Y5D、D-Y69 及 D-Y7 时, 气爪不可以通孔安装  
Note) When using Magnetic switches D-Y59, D-Y69, D-Y7, through-hole mounting is not possible.

# 平行夹 Parallel Gripper

Profile, SUS Tube  
型材、钢管

Stents Module  
支架模组

Quick Changer  
快换

Grip Module  
夹具组件

Air Nipper  
气动剪刀

Vacuum Module  
真空组件

Accessory Components  
附件

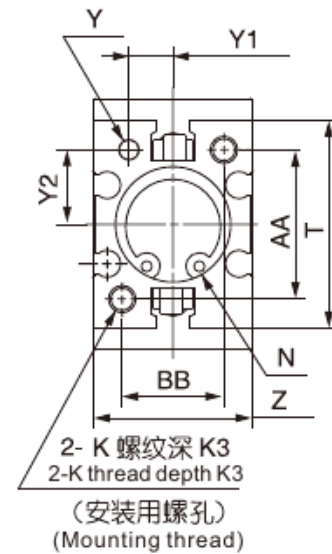
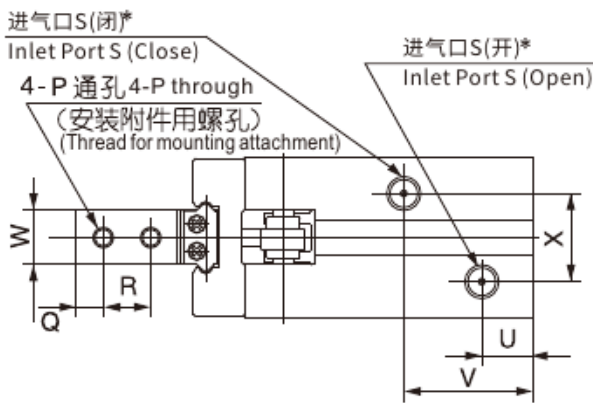
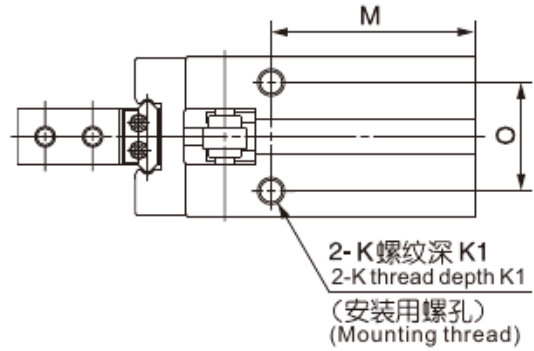
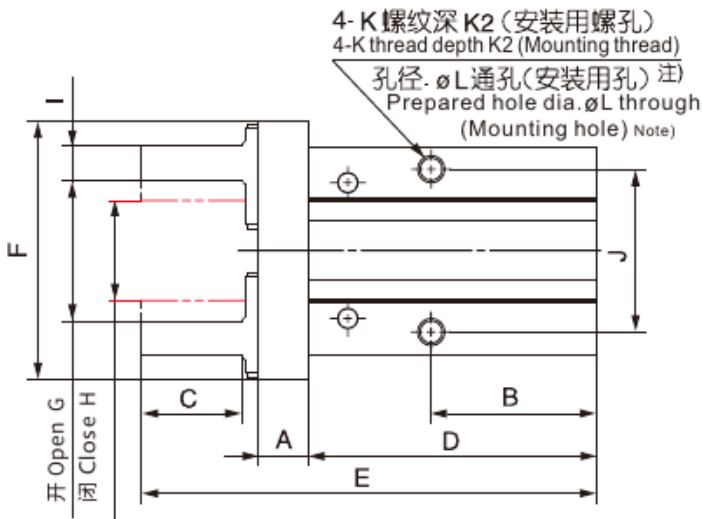

\* 单作用场合, 一侧通口变成呼吸孔。  
\* For single action, the port on one side is a breathing hole.

## 尺寸表 (mm)

Dimensions table

缸径(Bore)	A	B	C	D	E	F	G	H	I	J	K	K1	K2	K3	øL	M	N
10	6	23	12	37.8	57	29	15.2 <sup>±0.1</sup>	11.2 <sup>±0.1</sup>	4 <sup>±0.1</sup>	16	M3x0.5	6	5.5	6	2.6	27	ø11H9/T2
16	7.5	24.5	15	42.5	67.3	38	20.9 <sup>±0.1</sup>	14.9 <sup>±0.1</sup>	5 <sup>±0.1</sup>	24	M4x0.7	4.5	8	8	3.4	30	ø17H9/T2
20	9.5	29	20	52.8	84.8	50	26.3 <sup>±0.1</sup>	16.3 <sup>±0.1</sup>	8 <sup>±0.1</sup>	30	M5x0.8	8	10	10	4.3	35	ø21H9/T3
25	11	30	25	63.6	102.7	63	33.3 <sup>±0.1</sup>	19.3 <sup>±0.1</sup>	10 <sup>±0.1</sup>	36	M6x1	10	12	12	5.1	36.5	ø26H9/T3.5
32	12	40(49)	29	67(76)	113(122)	97	48 <sup>±0.1</sup>	26 <sup>±0.1</sup>	12 <sup>±0.1</sup>	46	M6x1	10	13	13	5.1	48(57)	ø34H9/T4
40	15	49(62)	36	83(96)	139(152)	119	60 <sup>±0.1</sup>	30 <sup>±0.1</sup>	14 <sup>±0.1</sup>	56	M8x1.25	13	16	17	6.6	58(71)	ø42H9/T4

缸径(Bore)	O	P	Q	R	S	T	U	V	W	X	Y	Z	Y1	Y2	AA	BB	CC	DD	EE
10	11.4	M2.5x0.45	3	5.7	M3x0.5	23	9	19	5 <sup>±0.1</sup>	11	ø2H9/T3	16.4 <sup>±0.1</sup>	5.2 <sup>±0.1</sup>	7.6 <sup>±0.1</sup>	18	12	-	-	-
16	16	M3x0.5	4	7	M5x0.8	30.6	7.5	19	8 <sup>±0.1</sup>	13	ø3H9/T3	23.6 <sup>±0.1</sup>	6.5 <sup>±0.1</sup>	11 <sup>±0.1</sup>	22	15	11.6	2.1	5.8
20	18.6	M4x0.7	5	9	M5x0.8	42	10	23	10 <sup>±0.1</sup>	15	ø4H9/T4	27.6 <sup>±0.1</sup>	7.5 <sup>±0.1</sup>	16.8 <sup>±0.1</sup>	32	18	14	2.1	9
25	22	M5x0.8	6	12	M5x0.8	52	10.7	23.5	12 <sup>±0.1</sup>	20	ø4H9/T4	33.6 <sup>±0.1</sup>	10 <sup>±0.1</sup>	21.8 <sup>±0.1</sup>	40	22	19	3.5	11.5
32	26	M6x1	7	14	M5x0.8	60	11	31(37)	15 <sup>±0.1</sup>	24	ø5H9/T5	40 <sup>±0.1</sup>	12 <sup>±0.1</sup>	23 <sup>±0.1</sup>	46	26	24	3.3	11.5
40	32	M8x1.25	9	17	M5x0.8	72	12	38(45)	18 <sup>±0.1</sup>	28	ø5H9/T5	48 <sup>±0.1</sup>	14 <sup>±0.1</sup>	29 <sup>±0.1</sup>	56	32	29.4	3.7	13

注( )内的尺寸为单动的尺寸  
The size of the single action is within ( ).

# 平行夹

## Parallel Gripper



### 型号表示方法

#### Model representation methods

[标准型]  
Standard type

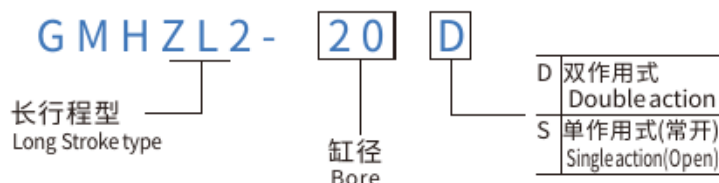

货号 PN	型号 Model	缸径 Bore	压力范围(MPa) Pressure Range		温度范围 Temperature range	重复精度 Repetition accuracy	最高使用频率 (c.p.m) Maximum frequency of use	接管口径 Nozzle diameter	重量 Weight	夹持力(N) Gripping force (N)			两侧开闭 行程(mm) Opening and closing stroke on both sides
			单作用 Single Action	双作用 Double action						双动 Double action			
										外径 External	内径 Internal		
1.Y09405	GMHXL2-10S	10	0.35-0.7	/	-10-60°C	±0.01	120	M3*0.5	63g	7.1	11	17	8
1.Y07974	GMHXL2-10D	10	/	0.2-0.7	-10-60°C	±0.01	120	M3*0.5	59g	7.1	11	17	8
1.Y08175	GMHXL2-16S	16	0.25-0.7	/	-10-60°C	±0.01	120	M5*0.8	139g	27	34	45	12
1.Y08146	GMHXL2-16D	16	/	0.1-0.7	-10-60°C	±0.01	120	M5*0.8	130g	27	34	45	12
1.Y09882	GMHXL2-20S	20	0.25-0.7	/	-10-60°C	±0.01	120	M5*0.8	218g	33	42	66	18
1.Y07975	GMHXL2-20D	20	/	0.1-0.7	-10-60°C	±0.01	120	M5*0.8	211g	33	42	66	18
1.Y09883	GMHXL2-25S	25	0.25-0.7	/	-10-60°C	±0.01	120	M5*0.8	302g	50	65	104	22
1.Y08802	GMHXL2-25D	25	/	0.1-0.7	-10-60°C	±0.01	120	M5*0.8	293g	50	65	104	22

备注:  
1. 采用空气流体  
2. 动作方式单作用双作用(可选)  
3. 可选无触点磁性开关

Notes:  
1, Air Fluid  
2, action mode single-acting double-acting (optional)  
3, optional non-contact magnetic switch

## 尺寸表(mm)

### Dimensions table

GMHXL2-10□磁性开关安装槽尺寸  
GMHXL2-10□Magnetic Switch Mounting Groove Dimensions

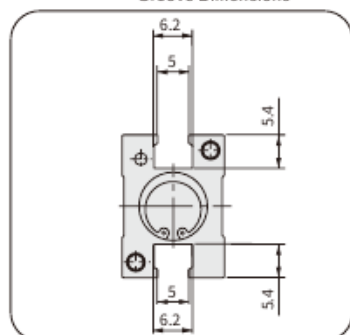

注)使用磁性开关时,气爪不可以通孔安装  
Note) When using Magnetic switches, throughhole mounting is not possible.

GMHXL2-□□磁性开关安装槽尺寸  
GMHXL2-□□Magnetic Switch Mounting Groove Dimensions

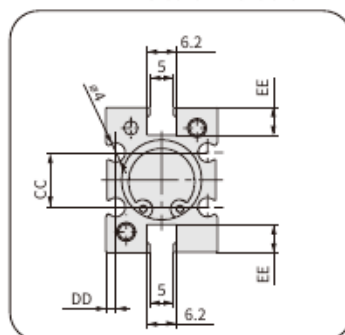

注)使用磁性开关D-Y59、D-Y69及D-Y7时,气爪不可以通孔安装  
Note) When using Magnetic switches D-Y59, D-Y69, D-Y7, throughhole mounting is not possible.

Profile- SUS Tube  
型材、钢管

Stents Module  
支架模组

Quick Changer  
快换

Grip Module  
夹具组件

Air Nipper  
气动剪刀

Vacuum Module  
真空组件

Accessory Components  
附件

# 平行夹 Parallel Gripper

Profile, SUS Tube  
型材、钢管

Stents Module  
支架模组

Quick Changer  
快换

Grip Module  
夹具组件

Air Nipper  
气动剪刀

Vacuum Module  
真空组件

Accessory Components  
附件

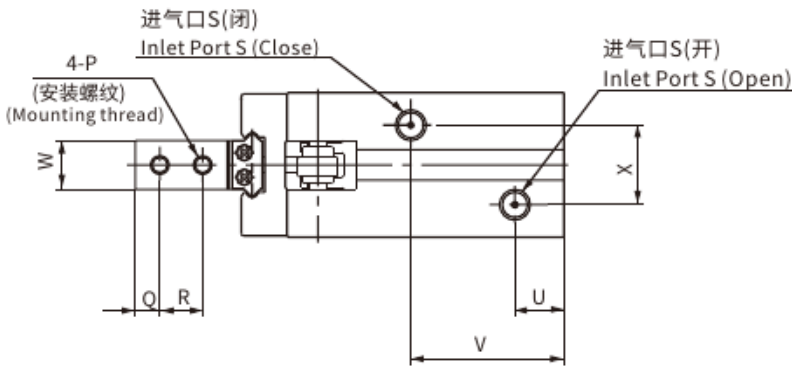
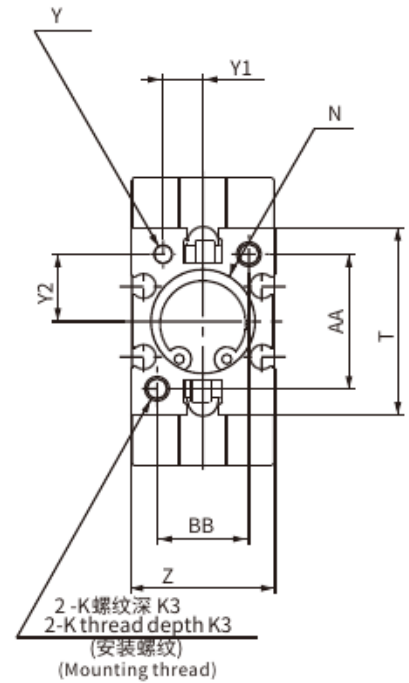
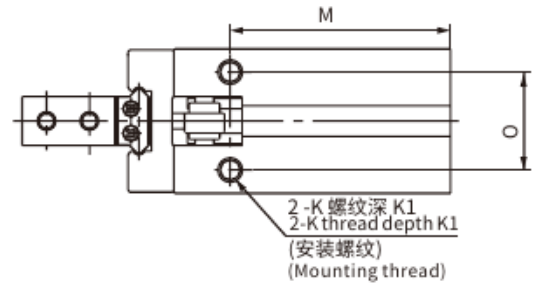
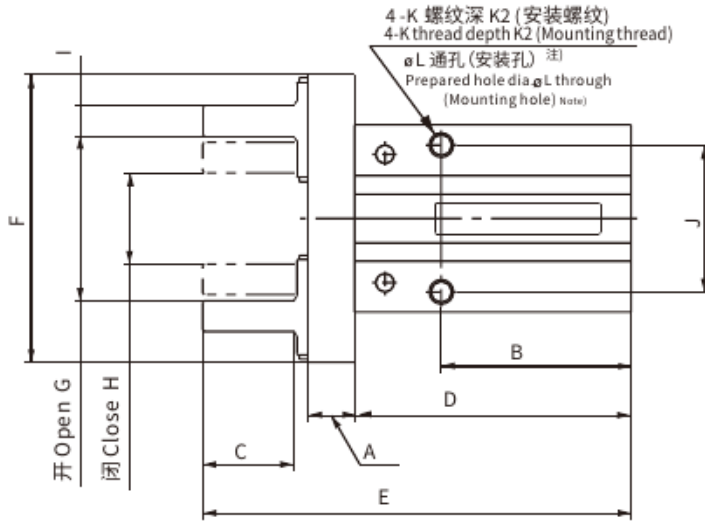

- \* 单作用场合，一侧通口变成呼吸孔。
- \* For single action, the port on one side is a breathing hole.

## 尺寸表 (mm) Dimensions table

缸径(Bore)	A	B	C	D	E	F	G	H	I	J	K	K1	K2	K3	øL	M	N
10	6	25(35)	12	37.8(47.8)	57(67)	35	19.2 <sup>±0.1</sup>	11.2 <sup>±0.1</sup>	4 <sup>±0.1</sup>	16	M3x0.5	6	5.5	6	2.6	29(39)	ø11H9T2
16	7.5	31(36)	15	45.2(50.2)	70(75)	47	26.9 <sup>±0.1</sup>	14.9 <sup>±0.1</sup>	5 <sup>±0.1</sup>	24	M4x0.7	4.5	8	8	3.4	36(41)	ø17H9T2
20	9.5	36(42)	20	58(64)	90(96)	62	34.3 <sup>±0.1</sup>	16.3 <sup>±0.1</sup>	8 <sup>±0.1</sup>	30	M5x0.5	8	10	10	4.3	43(49)	ø21H9T3
25	11	40(50)	25	66.9(76.9)	106(116)	75	41.3 <sup>±0.1</sup>	19.3 <sup>±0.1</sup>	10 <sup>±0.1</sup>	36	M6x1	10	12	12	5.1	48(58)	ø26H9T3.5

缸径(Bore)	O	P	Q	R	S	T	U	V	W	X	Y	Z	Y1	Y2	AA	BB	CC	DD	EE
10	11.4	M2.5x0.45	3	5.7	M3x0.5	23	8	21(31)	5 <sup>±0.1</sup>	11	ø2H9T3	16.4 <sup>±0.1</sup>	5.2 <sup>±0.1</sup>	7.6 <sup>±0.1</sup>	18	12	-	-	-
16	16	M3x0.5	4	7	M5x0.8	30.6	8	25(30)	8 <sup>±0.1</sup>	13	ø2H9T3	23.6 <sup>±0.1</sup>	6.5 <sup>±0.1</sup>	11 <sup>±0.1</sup>	22	15	11.6	2.1	5.8
20	18.6	M4x0.7	5	9	M5x0.8	42	10	30(36)	10 <sup>±0.1</sup>	15	ø4H9T4	27.6 <sup>±0.1</sup>	7.5 <sup>±0.1</sup>	16.8 <sup>±0.1</sup>	32	18	14	2.1	9
25	22	M5x0.8	6	12	M5x0.8	52	10	33(43)	12 <sup>±0.1</sup>	20	ø4H9T4	33.6 <sup>±0.1</sup>	10 <sup>±0.1</sup>	21.8 <sup>±0.1</sup>	40	22	19	3.5	11.5

注) ( )内的尺寸为单动的尺寸  
The size of the single action is within ( ).

# 双钳口平动式抓手

## Double jaw translating gripper

- 小尺寸, 高性能。
- 结构坚固, 运行平稳, 寿命长。
- 多种安装和进给选项。
- 双动单指行程2。

- Small size, high performance.
- Tightly constructed for smooth operation and long life.
- Multiple mounting and feed options.
- Double-acting, single-piston stroke 2.



货号(PN)	8.Y01295
型号(Model)	GFPT-20S
重量Weight	37g

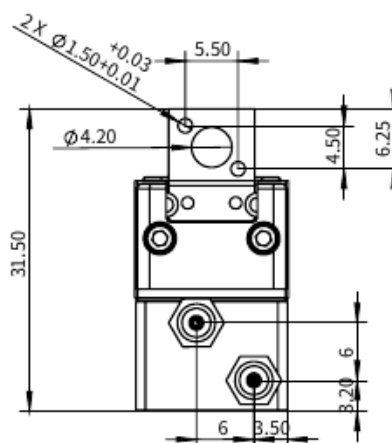
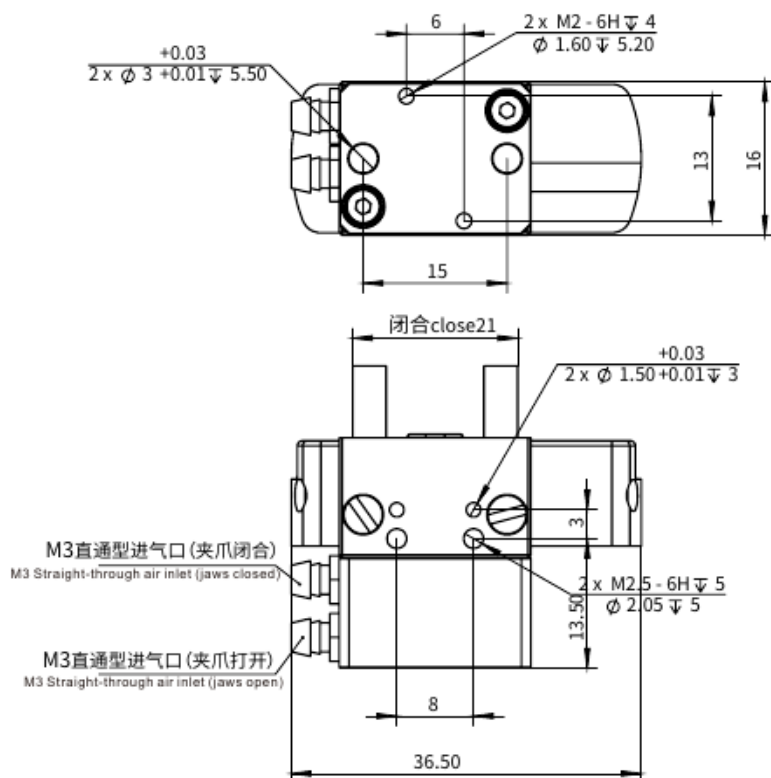

Profile - SUS Tube  
型材、钢管

Stents Module  
支架模组

Quick Changer  
快换

Grip Module  
夹具组件

Air Nipper  
气动剪刀

Vacuum Module  
真空组件

Accessory Components  
附件

# 水口夹具 Sprue Gripper

## 型号表示方法

Model representation methods

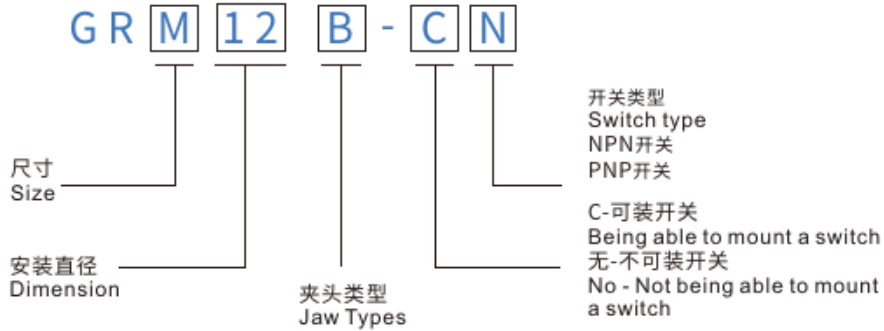

## 开关接线说明

Switch wiring instructions

NPN输出型 / NPN output type

输入、输出电路图  
Input and output circuit diagrams

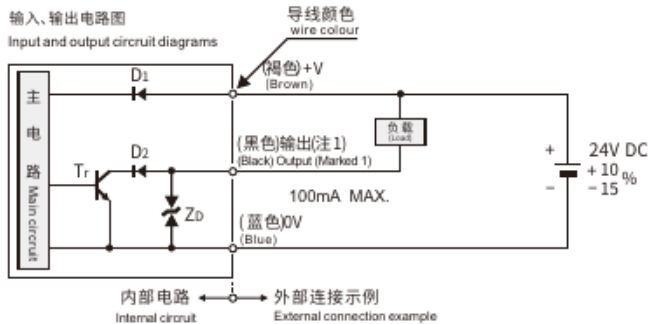

(注1): 输出未装备短路保护电路。请勿直接连接电源或容性负载。  
(Marked 1) Output is not equipped with short-circuit protection circuit. Do not connect directly to power or capacitive loads.

PNP输出型 / PNP output type

输入、输出电路图  
Input and output circuit diagrams

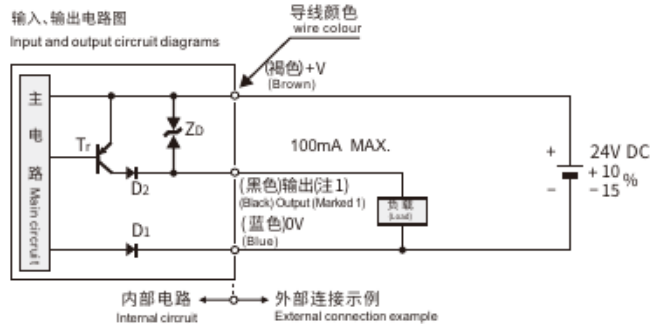

(注1): 输出未装备短路保护电路。请勿直接连接电源或容性负载。  
(Marked 1) Output is not equipped with short-circuit protection circuit. Do not connect directly to power or capacitive loads.

## 案例

Case

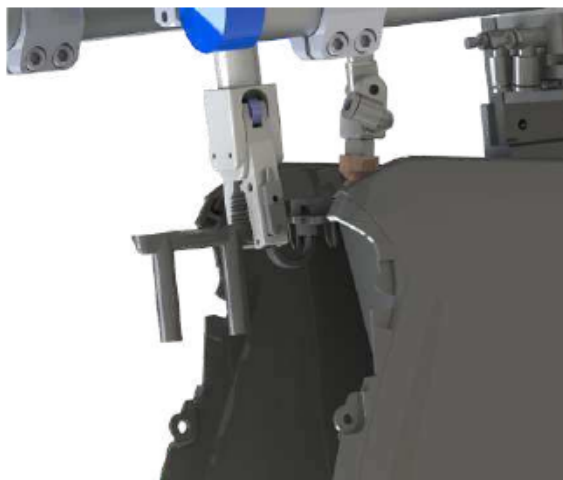

## 选配件

Accessories selection



接近传感器  
Sensor  
1. PNP  
2. NPN

开关货号(PN)	型号(Model)
7.Y00800	E2S-W15(PNP)
7.Y00801	E2S-W13(NPN)

注: 线长为1米  
Note: The length is 1 meter

## 水口夹具 Sprue Gripper

本体使用超硬铝材料，重量轻刚性强，寿命长。  
组装时可选择螺纹安装和CRG部品安装。

Main body being made of high-strength Aluminium, light weight, strong rigidity and long life cycle.  
Using threaded components or CRG's components when to assemble.

### 水口夹具GR(S/M/L/X)系列(无传感器) Series GR-Sprue Gripper (Without Sensor)



### 水口夹具GR(S/M/L/X)系列(带传感器) Series GR -Sprue Gripper (With Sensor)



货号(PN)	型号(Model)	信号开关(Switch type)	抓取力(F)	重量(Weight)
8.Y00214	GRS08	-	5N	18g
8.Y00011	GRS08-CN	NPN	5N	40g
8.Y00012	GRS08-CP	PNP	5N	40g
8.Y00103	GRM12A	-	28N	46g
8.Y00009	GRM12A-CN	NPN	28N	60g
8.Y00010	GRM12A-CP	PNP	28N	60g
8.Y00107	GRM12B	-	28N	46g
8.Y00104	GRM12B-CN	NPN	28N	60g
8.Y00105	GRM12B-CP	PNP	28N	60g
8.Y00108	GRL12A	-	45N	94g
8.Y00001	GRL12A-CN	NPN	45N	100g
8.Y00002	GRL12A-CP	PNP	45N	100g
8.Y00213	GRX20	-	80N	180g
8.Y00013	GRX20-CN	NPN	80N	192g
8.Y00014	GRX20-CP	PNP	80N	192g

Profile- SUS Tube  
型材、钢管

Stents Module  
支架模组

Quick Changer  
快换

Grip Module  
夹具组件

Air Nipper  
气动剪刀

Vacuum Module  
真空组件

Accessory Components  
附件

# GRS08系列

## GRS08 Series

### GRS08系列

本体使用超硬铝材料,重量轻刚性强,寿命长。

组装时可选择螺纹安装和CRG部品安装。

#### Series GRS08

Main body being made of high-strength Aluminium , light weight , strong rigidity and long life cycle.

Using threaded components or CRG's components when to assemble.

Profile、SUS Tube  
型材、钢管

Stents Module  
支架模组

Quick Changer  
快换

Grip Module  
夹具组件

Air Nipper  
气动剪刀

Vacuum Module  
真空组件

Accessory Components  
附件



GRS08  
无传感器(Without Sensor)



钻石齿  
Diamond tooth

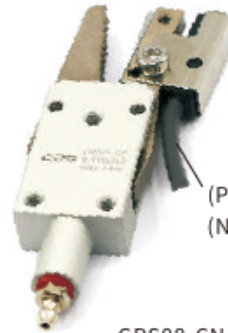

GRS08-CN(CP)  
带传感器(With Sensor)

(PNP)  
(NPN)

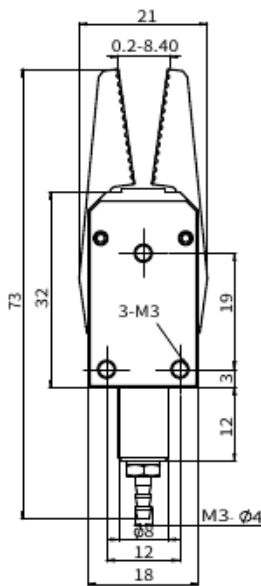

无传感器(Without Sensor)

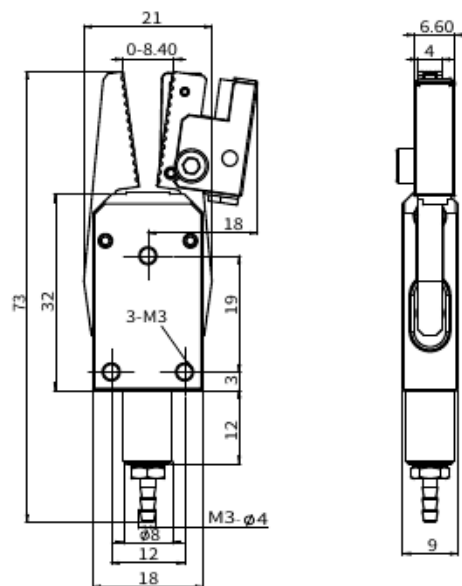

带传感器(With Sensor)

货号(PN)	型号(Model)	传感器(Sensor)	抓取力(F)	重量(Weight)
8.Y00214	GRS08	-	5N	18g
8.Y00011	GRS08-CN	NPN	5N	40g
8.Y00012	GRS08-CP	PNP	5N	40g

# GRM12系列

## GRM12 Series

### GRM12系列

本体使用超硬铝材料,重量轻刚性强,寿命长。

组装时可选择螺纹安装和CRG部品安装。

#### Series GRM12

Main body being made of high-strength Aluminium , light weight , strong rigidity and long life cycle.

Using threaded components or CRG's components when to assemble.



GRM12A  
无传感器(Without Sensor)



A 钻石齿  
A Diamond tooth



B 斜齿  
B Helical tooth



GRM12A-CN(CP)  
带传感器(With Sensor)

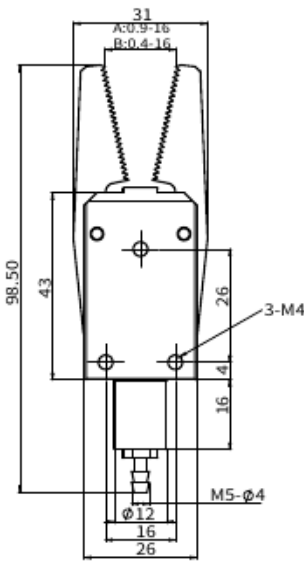

无传感器(Without Sensor)

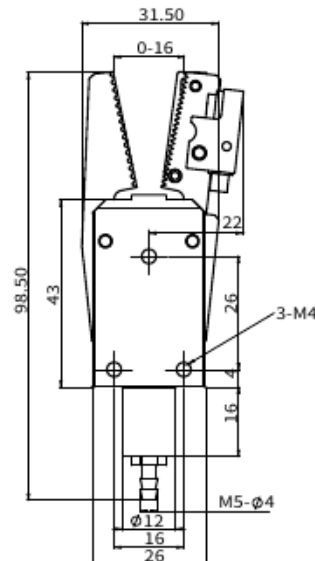

带传感器(With Sensor)



货号(PN)	型号(Model)	传感器(Sensor)	抓取力(F)	重量(Weight)
8.Y00103	GRM12A	-	28N	46g
8.Y00107	GRM12B	-	28N	46g
8.Y00009	GRM12A-CN	NPN	28N	60g
8.Y00010	GRM12A-CP	PNP	28N	60g
8.Y00104	GRM12B-CN	NPN	28N	60g
8.Y00105	GRM12B-CP	PNP	28N	60g

Profile- SUS Tube  
型材、钢管

Stents Module  
支架模组

Quick Changer  
快换

Grip Module  
夹具组件

Air Nipper  
气动剪刀

Vacuum Module  
真空组件

Accessory Components  
附件

# GRL12系列

## GRL12 Series

### GRL12系列

本体使用超硬铝材料,重量轻刚性强,寿命长。

组装时可选择螺纹安装和CRG部品安装。

#### Series GRL 12

Main body being made of high-strength Aluminium , light weight , strong rigidity and long life cycle.

Using threaded components or CRG's components when to assemble.

Profile, SUS Tube  
型材、钢管

Stents Module  
支架模组

Quick Changer  
快换

Grip Module  
夹具组件

Air Nipper  
气动剪刀

Vacuum Module  
真空组件

Accessory Components  
附件



GRL12A  
无传感器(Without Sensor)



钻石齿  
Diamond tooth



GRL12A-CN(CP)  
带传感器(With Sensor)

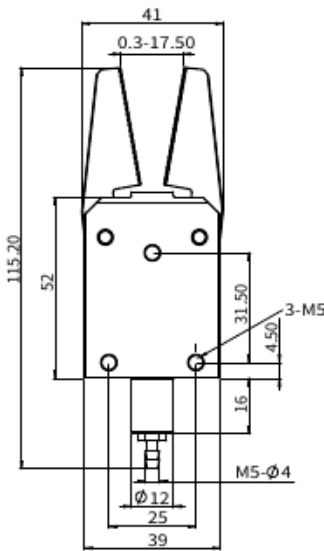

无传感器(Without Sensor)

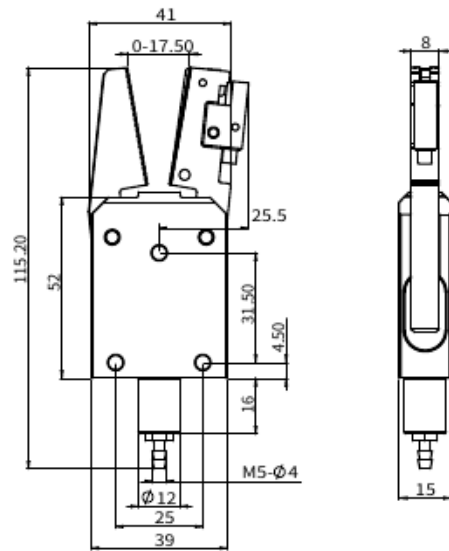

带传感器(With Sensor)

货号(PN)	型号(Model)	传感器(Sensor)	抓取力(F)	重量(Weight)
8.Y00108	GRL12A	-	45N	94g
8.Y00001	GRL12A-CN	NPN	45N	100g
8.Y00002	GRL12A-CP	PNP	45N	100g

# GRX20系列

## GRX20 Series

### GRX20系列

本体使用超硬铝材料,重量轻刚性强,寿命长。

组装时可选择螺纹安装和CRG部品安装。

#### Series GRX20

Main body being made of high-strength Aluminium , light weight , strong rigidity and long life cycle.

Using threaded components or CRG's components when to assemble.



GRX20  
无传感器(Without Sensor)



钻石齿  
Diamond tooth



GRX20-CN(CP)  
带传感器(With Sensor)

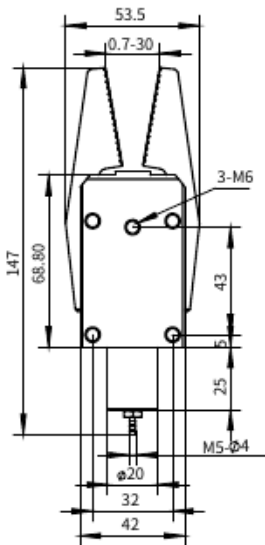

无传感器(Without Sensor)

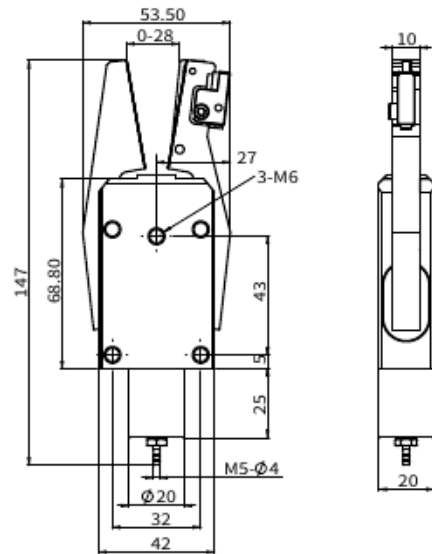

带传感器(With Sensor)

货号(PN)	型号(Model)	传感器(Sensor)	抓取力(F)	重量(Weight)
8.Y00213	GRX20	-	80N	180g
8.Y00013	GRX20-CN	NPN	80N	192g
8.Y00014	GRX20-CP	PNP	80N	192g

Profile- SUS Tube  
型材、钢管

Stents Module  
支架模组

Quick Changer  
快换

Grip Module  
夹具组件

Air Nipper  
气动剪刀

Vacuum Module  
真空组件

Accessory Components  
附件

# 水口夹具 Sprue Gripper

## 型号表示方法

Model representation methods

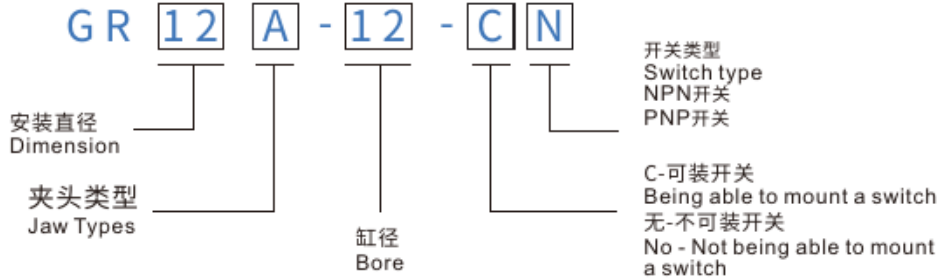

## 开关接线说明

Switch wiring instructions

NPN输出型 / NPN output type

输入、输出电路图

Input and output circuit diagrams

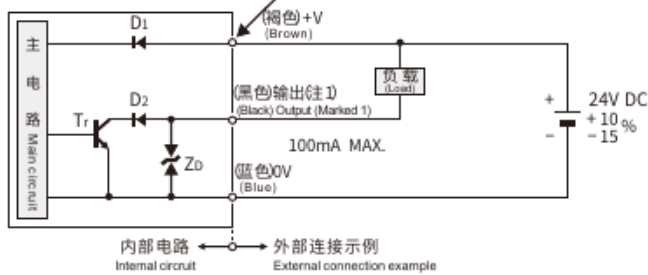

(注1): 输出未装备短路保护电路。请勿直接连接电源或容性负载。  
(Marked 1) Output is not equipped with short-circuit protection circuit. Do not connect directly to power or capacitive loads.

PNP输出型 / PNP output type

输入、输出电路图

Input and output circuit diagrams

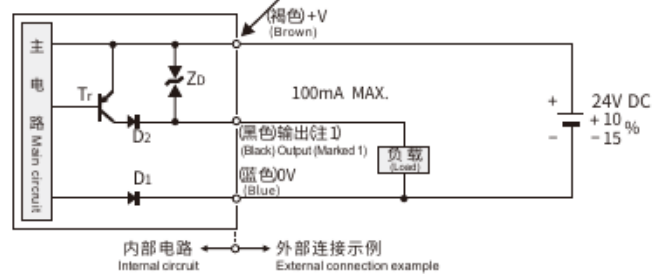

(注1): 输出未装备短路保护电路。请勿直接连接电源或容性负载。  
(Marked 1) Output is not equipped with short-circuit protection circuit. Do not connect directly to power or capacitive loads.

## 案例

Case

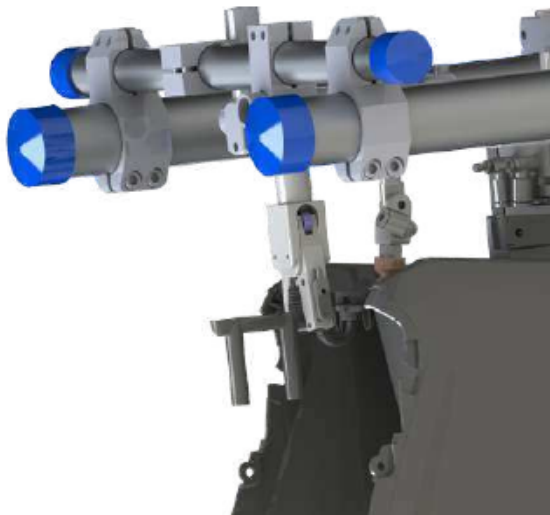

## 选配件

Accessories selection



开关

Sensor

1. PNP

2. NPN

开关货号(PN)	型号(Model)
1.Y13685	MAP-8S2P1/F (PNP)
1.Y13686	MAP-8S2N1/F (NPN)

注: 线长为1米  
Note: The length is 1 meter



开关

Sensor

1. PNP

2. NPN

开关货号(PN)	型号(Model)
1.Y13687	MAP-8S1.5P1/F CP
1.Y13688	MAP-8S1.5N1/F CN

注: 线长为1米  
Note: The length is 1 meter

# 水口夹具

## Sprue Gripper

本体使用超硬铝材料,重量轻刚性强,寿命长。  
 组装时可选择螺纹安装和CRG部品安装。

Main body being made of high-strength Aluminium , light weight , strong rigidity and long life cycle.  
 Using threaded components or CRG's components when to assemble.



GR05A-10  
 无传感器  
 (Without Sensor)



GR10A-12  
 无传感器  
 (Without Sensor)



GR10A-12-CN(CP)  
 带传感器  
 (With Sensor)



GR10D-12  
 无传感器  
 (Without Sensor)



GR10D-12-CP(CN)  
 带传感器  
 (With Sensor)



GR12A-12  
 无传感器  
 (Without Sensor)



GR12A-12-CN(CP)  
 带传感器  
 (With Sensor)



GR12B-12  
 无传感器  
 (Without Sensor)



GR12B-12-CP(CN)  
 带传感器  
 (With Sensor)



GR10/12L-12  
 无传感器  
 (Without Sensor)

货号(PN)	型号(Model)	传感器(Sensor)	抓取力(F)	重量(Weight)
8.Y00348	GR05A-10	-	12N	9.6g
8.Y00268	GR10A-12	-	28N	44g
8.Y00267	GR10A-12-CP	PNP	28N	70g
8.Y00305	GR10A-12-CN	NPN	28N	70g
8.Y00370	GR10D-12	-	28N	42g
8.Y00369	GR10D-12-CP	PNP	28N	61g
8.Y01034	GR10D-12-CN	NPN	28N	61g
8.Y00048	GR12A-12	-	28N	44g
8.Y00050	GR12A-12-CP	PNP	28N	70g
8.Y00091	GR12A-12-CN	NPN	28N	70g
8.Y00245	GR12B-12	-	28N	44g
8.Y00261	GR12B-12-CP	PNP	28N	70g
8.Y00262	GR12B-12-CN	NPN	28N	70g
8.Y00307	GR10L-12	-	28N	50g
8.Y00308	GR12L-12	-	28N	50g

Profile- SUStube  
 型材、钢管

Stents Module  
 支架模组

Quick Changer  
 快换

Grip Module  
 夹具组件

Air Nipper  
 气动剪刀

Vacuum Module  
 真空组件

Accessory Components  
 附件

## 水口夹具 Sprue Gripper

本体使用超硬铝材料，重量轻刚性强，寿命长。  
组装时可选择螺纹安装和CRG部品安装。

Main body being made of high-strength Aluminium, light weight, strong rigidity and long life cycle.  
Using threaded components or CRG's components when to assemble.



GR10/12L-12-CP(CN)  
带传感器  
(With Sensor)



GR12M-12  
无传感器  
(Without Sensor)



GR12M-12-CN(CP)  
带传感器  
(With Sensor)



GR12N-12  
无传感器  
(Without Sensor)



GR12N-12-CN(CP)  
带传感器  
(With Sensor)

货号(PN)	型号(Model)	传感器(Sensor)	抓取力(F)	重量(Weight)
8.Y01053 (精制铝Casteel jaws)	GR10L-12-CP	PNP	28N	116g
8.Y01054 (精制铝Casteel jaws)	GR10L-12-CN	NPN	28N	116g
8.Y01020 (精制铝Casteel jaws)	GR12L-12-CP	PNP	28N	116g
8.Y01021 (精制铝Casteel jaws)	GR12L-12-CN	NPN	28N	116g
8.Y00419 (精制铝Casteel jaws)	GR12M-12	-	28N	66.2g
8.Y00421 (精制铝Casteel jaws)	GR12M-12-CP	PNP	28N	82.5g
8.Y00420 (精制铝Casteel jaws)	GR12M-12-CN	NPN	28N	82.5g
8.Y01011	GR10N-12	-	28N	42g
8.Y01018	GR10N-12-CP	PNP	28N	74.3g
8.Y01019	GR10N-12-CN	NPN	28N	74.3g
8.Y01012	GR12N-12	-	28N	42g
8.Y01084	GR12N-12-CP	PNP	28N	74.3g
8.Y01083	GR12N-12-CN	NPN	28N	74.3g

Profile, SUS Tube  
型材、钢管

Stents Module  
支架模组

Quick Changer  
快换

Grip Module  
夹具组件

Air Gripper  
气动夹刀

Vacuum Module  
真空组件

Accessory Components  
附件

# GR05A系列

## GR05A Series

### GR05A系列

本体使用超硬铝材料,重量轻刚性强,寿命长。

组装时可选择螺纹安装和CRG部品安装。

#### Series GR05A

Main body being made of high-strength Aluminium , light weight , strong rigidity and long life cycle.  
Using threaded components or CRG's components when to assemble.

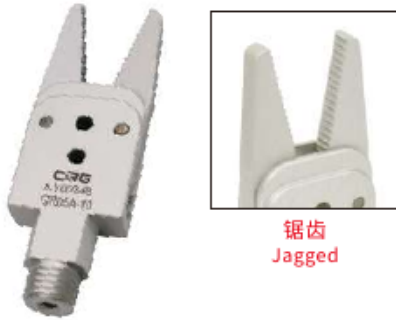

GR05A-10  
无传感器(Without Sensor)

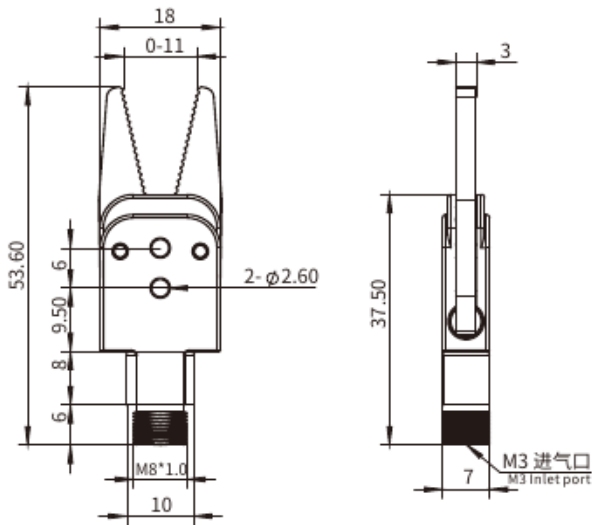

货号(PN)	型号(Model)	传感器(Sensor)	抓取力(F)	重量(Weight)
8.Y00348	GR05A-10	-	12N	9.6g

Profile- SUS Tube  
型材、钢管

Stents Module  
支架模组

Quick Changer  
快换

Grip Module  
夹具组件

Air Nipper  
气动剪刀

Vacuum Module  
真空组件

Accessory Components  
附件

# GR10A系列

## GR10A Series

### GR10A系列

本体使用超硬铝材料,重量轻刚性强,寿命长。

组装时可选择螺纹安装和CRG部品安装。

#### Series GR10A

Main body being made of high-strength Aluminium, light weight, strong rigidity and long life cycle.

Using threaded components or CRG's components when to assemble.

Profile、SUS Tube  
型材、钢管

Stents Module  
支架模组

Quick Changer  
快换

Grip Module  
夹具组件

Air Nipper  
气动剪刀

Vacuum Module  
真空组件

Accessory Components  
附件



GR10A-12  
无传感器(Without Sensor)



钻石齿  
Diamond tooth



GR10A-12-CN(CP)  
带传感器(With Sensor)

MAP-8S2P1/F(PNP)  
MAP-8S2N1/F(NPN)

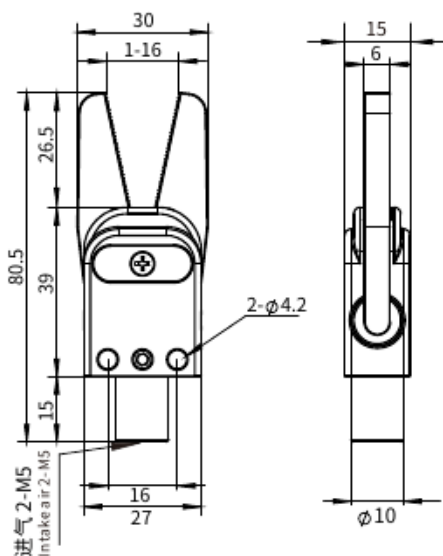

无传感器(Without Sensor)

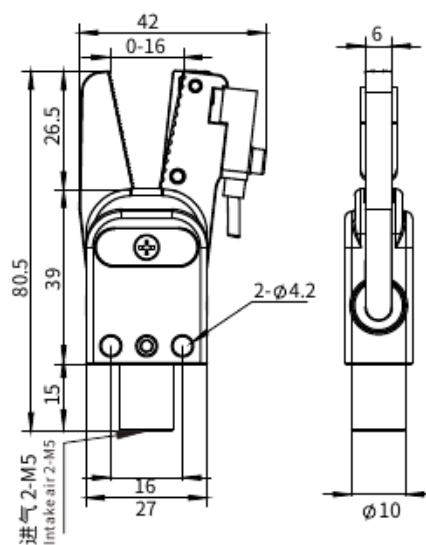

带传感器(With Sensor)

货号(PN)	型号(Model)	传感器(Sensor)	抓取力(F)	重量(Weight)
8.Y00268	GR10A-12	-	28N	44g
8.Y00267	GR10A-12-CP	PNP	28N	70g
8.Y00305	GR10A-12-CN	NPN	28N	70g

# GR10D系列

## GR10D Series

### GR10D系列

本体使用超硬铝材料,重量轻刚性强,寿命长。

组装时可选择螺纹安装和CRG部品安装。

#### Series GR10D

Main body being made of high-strength Aluminium , light weight , strong rigidity and long life cycle.

Using threaded components or CRG's components when to assemble.



GR10D-12  
无传感器(Without Sensor)



斜齿  
Helical tooth



GR10D-12-CP(CN)  
带传感器(With Sensor)

MAP-8S2P1/F(PNP)  
MAP-8S2N1/F(NPN)

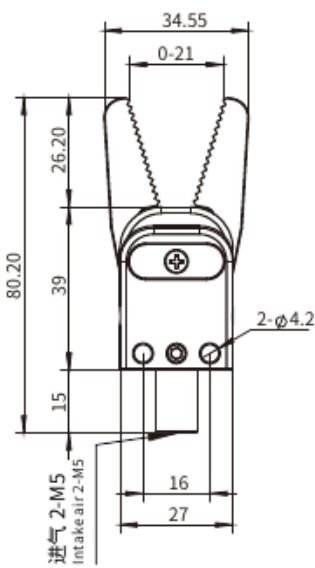

无传感器(Without Sensor)

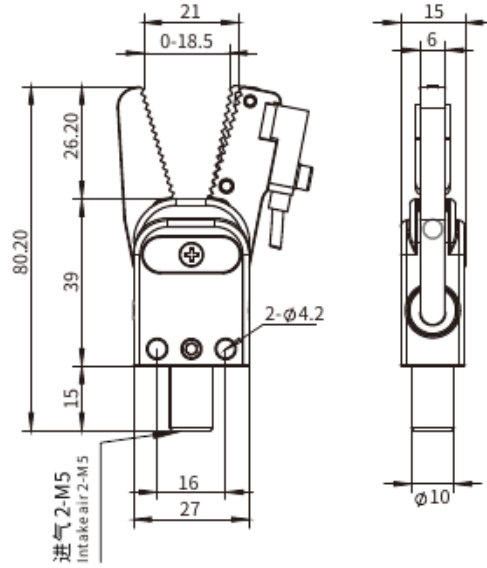

带传感器(With Sensor)

货号(PN)	型号(Model)	传感器(Sensor)	抓取力(F)	重量(Weight)
8.Y00370	GR10D-12	-	28N	42g
8.Y00369	GR10D-12-CP	PNP	28N	61g
8.Y01034	GR10D-12-CN	NPN	28N	61g

Profile、SUS Tube  
型材、钢管

Stents Module  
支架模组

Quick Changer  
快换

Grip Module  
夹具组件

Air Nipper  
气动剪刀

Vacuum Module  
真空组件

Accessory Components  
附件

# GR12A系列

## GR12A Series

### GR12A系列

本体使用超硬铝材料,重量轻刚性强,寿命长。

组装时可选择螺纹安装和CRG部品安装。

#### Series GR12A

Main body being made of high-strength Aluminium, light weight, strong rigidity and long life cycle.

Using threaded components or CRG's components when to assemble.



GR12A-12  
无传感器(Without Sensor)



钻石齿  
Diamond tooth



GR12A-12-CN(CP)  
带传感器(With Sensor)

MAP-8S2P1/F (PNP)  
MAP-8S2N1/F (NPN)

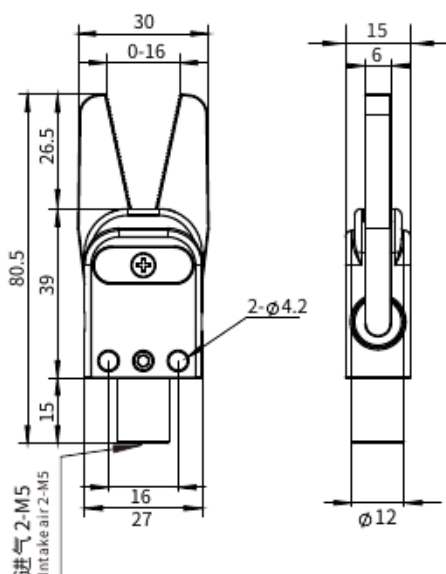

无传感器(Without Sensor)

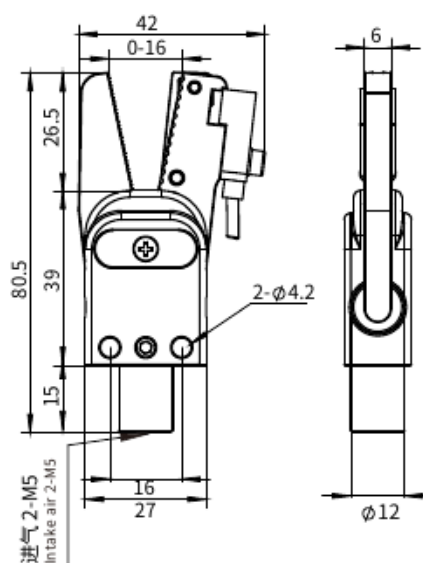

带传感器(With Sensor)

货号(PN)	型号(Model)	传感器(Sensor)	抓取力(F)	重量(Weight)
8.Y00048	GR12A-12	-	28N	44g
8.Y00050	GR12A-12-CP	PNP	28N	70g
8.Y00091	GR12A-12-CN	NPN	28N	70g

# GR12B系列

## GR12B Series

### GR12B系列

本体使用超硬铝材料,重量轻刚性强,寿命长。

组装时可选择螺纹安装和CRG部品安装。

#### Series GR12B

Main body being made of high-strength Aluminium , light weight , strong rigidity and long life cycle.

Using threaded components or CRG's components when to assemble.



GR12B-12  
无传感器(Without Sensor)



斜齿  
Helical tooth



GR12B-12-CP(CN)  
带传感器(With Sensor)

MAP-8S2P1/F(PNP)  
MAP-8S2N1/F(NPN)

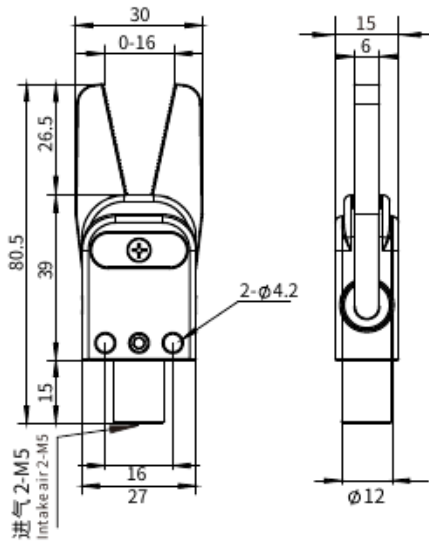

无传感器(Without Sensor)

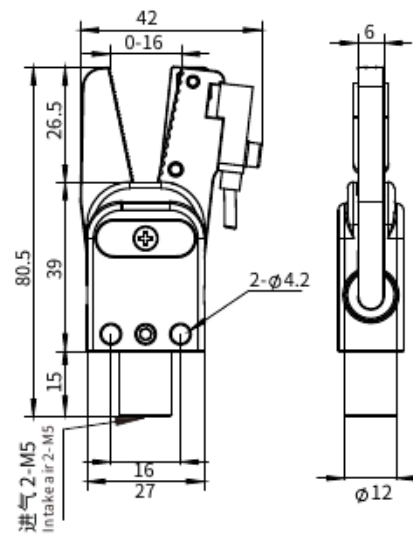

带传感器(With Sensor)

货号(PN)	型号(Model)	传感器(Sensor)	抓取力(F)	重量(Weight)
8.Y00245	GR12B-12	-	28N	44g
8.Y00261	GR12B-12-CP	PNP	28N	70g
8.Y00262	GR12B-12-CN	NPN	28N	70g

Profile- SUS Tube  
型材、钢管

Stents Module  
支架模组

Quick Changer  
快换

Grip Module  
夹具组件

Air Nipper  
气动剪刀

Vacuum Module  
真空组件

Accessory Components  
附件

# GR10/12L系列

## GR10/12L Series

### GR10/12L系列

本体使用超硬铝材料,重量轻刚性强,寿命长。

组装时可选择螺纹安装和CRG部品安装。

加宽钳口,加持的更稳更牢。

#### Series GR10/12L

Main body being made of high-strength Aluminium, light weight, strong rigidity and long life cycle.

Using threaded components or CRG's components when to assemble.

Wider Jaws, hold more stable and firm.



GR10/12L-12  
无传感器(Without Sensor)



GR10/12L-12-CP(CN)  
带传感器(With Sensor)

MAP-8S2P1/F(PNP)  
MAP-8S2N1/F(NPN)

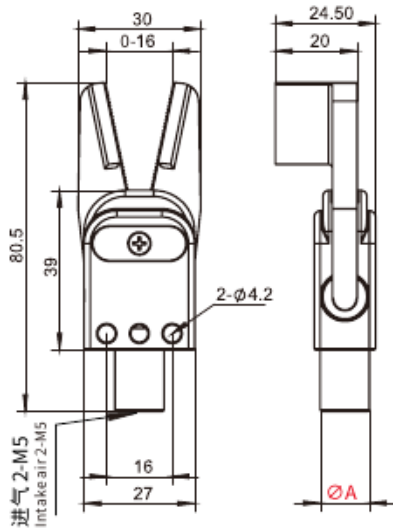

无传感器(Without Sensor)

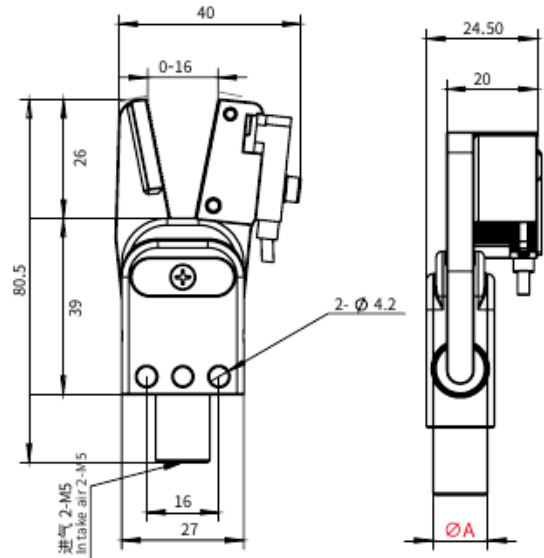

带传感器(With Sensor)

货号(PN)	型号(Model)	A	传感器(Sensor)	抓取力(F)	重量(Weight)
8.Y00307	GR10L-12	∅10	-	28N	50g
8.Y00308	GR12L-12	∅12	-	28N	50g
8.Y01053	GR10L-12-CP	∅10	PNP	28N	116g
8.Y01054	GR10L-12-CN	∅10	NPN	28N	116g
8.Y01020	GR12L-12-CP	∅12	PNP	28N	116g
8.Y01021	GR12L-12-CN	∅12	NPN	28N	116g

Profile, SUS Tube  
型材、钢管

Stents Module  
支架模组

Quick Changer  
快换

Grip Module  
夹具组件

Air Nipper  
气动剪刀

Vacuum Module  
真空组件

Accessory Components  
附件

# GR12M系列

## GR12M Series

### GR12M系列

本体使用超硬铝材料,重量轻刚性强,寿命长。

组装时可选择螺纹安装和CRG部品安装。

#### Series GR12M

Main body being made of high-strength Aluminium , light weight , strong rigidity and long life cycle. Using threaded components or CRG's components when to assemble.



GR12M-12  
无传感器(Without Sensor)



钢制钳口  
Steel jaw



GR12M-12-CN(CP)  
带传感器(With Sensor)

MAP-8S2P1/F(PNP)  
MAP-8S2N1/F(NPN)

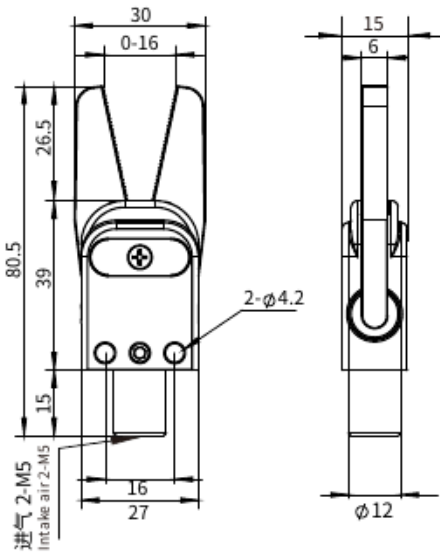

无传感器(Without Sensor)

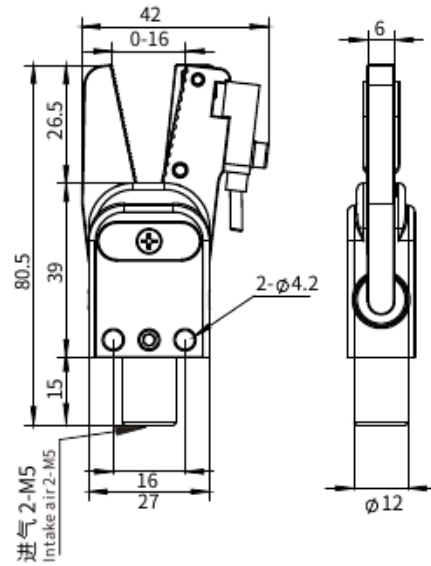

带传感器(With Sensor)

货号(PN)	型号(Model)	传感器(Sensor)	抓取力(F)	重量(Weight)
8.Y00419	GR12M-12	-	28N	66.2g
8.Y00421	GR12M-12-CP	PNP	28N	82.5g
8.Y00420	GR12M-12-CN	NPN	28N	82.5g

Profile- SUS Tube  
型材、钢管

Stents Module  
支架模组

Quick Changer  
快换

Grip Module  
夹具组件

Air Nipper  
气动剪刀

Vacuum Module  
真空组件

Accessory Components  
附件

# GR10/12N系列

## GR10/12N Series

GR10/12N系列

本体使用超硬铝材料,重量轻刚性强,寿命长。

组装时可选择螺纹安装和CRG部品安装。

Series GR10/12N

Main body being made of high-strength Aluminium, light weight, strong rigidity and long life cycle.

Using threaded components or CRG's components when to assemble.

Profile, SUS Tube  
型材、钢管

Stents Module  
支架模组

Quick Changer  
快换

Grip Module  
夹具组件

Air Nipper  
气动剪刀

Vacuum Module  
真空组件

Accessory Components  
附件



GR12N-12  
无传感器(Without Sensor)



货号(PN)	1.Y02630
型号(Model)	L25-6-16
重量(Weight)	0.7g



GR12N-12-CN(CP)  
带传感器(With Sensor)

MAP-8S2P1/F(PNP)  
MAP-8S2N1/F(NPN)

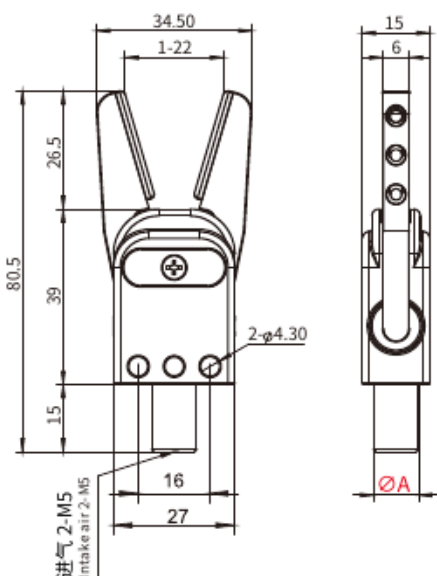

无传感器(Without Sensor)

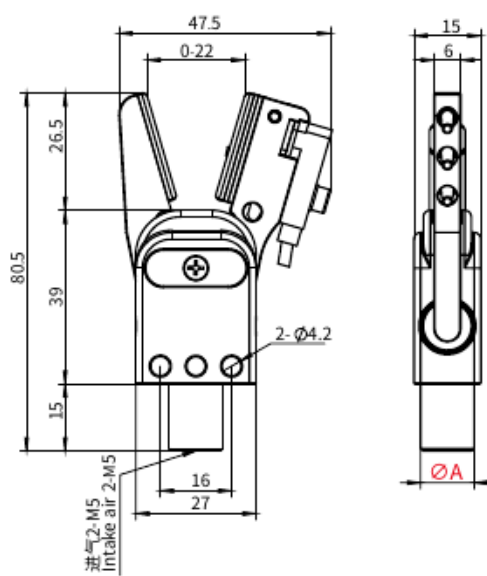

带传感器(With Sensor)

货号(PN)	型号(Model)	A	传感器(Sensor)	抓取力(F)	重量(Weight)
8.Y01011	GR10N-12	Ø10	-	28N	42g
8.Y01012	GR12N-12	Ø12	-	28N	42g
8.Y01018	GR10N-12-CP	Ø10	PNP	28N	74.3g
8.Y01019	GR10N-12-CN	Ø10	NPN	28N	74.3g
8.Y01084	GR12N-12-CP	Ø12	PNP	28N	74.3g
8.Y01083	GR12N-12-CN	Ø12	NPN	28N	74.3g

## 水口夹具 Sprue Gripper

1. 本体使用超硬铝材料,重量轻刚性强,寿命长。
  2. 组装时可选择螺纹安装和CRG部品安装。
  3. GR系列水口夹可选择不同的夹头形状,满足多种水口的夹取。
1. Main body being made of high-strength Aluminium , light weight , strong rigidity and long life cycle.
  2. Using threaded components or CRG's components when to assemble.
  3. GR series of sprue gripper can choose different types of jaws to satisfy the clamping of various sprue gate.



GR20A-20  
无传感器  
(Without Sensor)



GR20A-20-CN(CP)  
带传感器  
(With Sensor)



GR20B-20  
无传感器  
(Without Sensor)



GR20B-20-CN(CP)  
带传感器  
(With Sensor)



GR20C-20  
无传感器  
(Without Sensor)



GR20D-20  
无传感器  
(Without Sensor)



GR20D-20-CN(CP)  
带传感器  
(With Sensor)



GR20D-20M-(CN/CP)  
可选传感器  
(Optional Sensors)



GR20E-20  
无传感器  
(Without Sensor)



GR20F-20  
无传感器  
(Without Sensor)

货号(PN)	型号(Model)	传感器(Sensor)	抓取力(F)	重量(Weight)
8.Y01349	GR20A-20	-	80N	112g
8.Y01350	GR20A-20-CP	PNP	80N	137g
8.Y01351	GR20A-20-CN	NPN	80N	137g
8.Y01352	GR20B-20	-	80N	112g
8.Y01353	GR20B-20-CP	PNP	80N	137g
8.Y01354	GR20B-20-CN	NPN	80N	137g
8.Y01355	GR20C-20	-	80N	140g
8.Y01356	GR20D-20	-	80N	149g
8.Y01357	GR20D-20-CP	PNP	80N	173.1g
8.Y01358	GR20D-20-CN	NPN	80N	173.1g
8.Y01099	GR20D-20M	-	80N	163.6g
8.Y01100	GR20D-20M-CP	PNP	80N	170g
8.Y01101	GR20D-20M-CN	NPN	80N	170g
8.Y01359	GR20E-20	-	80N	129g
8.Y01360	GR20F-20	-	80N	128g

Profile- SUS Tube  
型材、钢管

Stents Module  
支架模组

Quick Changer  
快换

Grip Module  
夹具组件

Air Nipper  
气动剪刀

Vacuum Module  
真空组件

Accessory Components  
附件

# 水口夹具

## Sprue Gripper

Profile, SUS Tube  
型材、钢管

Stents Module  
支架模组

Quick Changer  
快换

Grip Module  
夹具组件

Air Nipper  
气动剪刀

Vacuum Module  
真空组件

Accessory Components  
附件

1. 本体使用超硬铝材料,重量轻刚性强,寿命长。
  2. 组装时可选择螺纹安装和CRG部品安装。
  3. GR系列水口夹可选择不同的夹头形状,满足多种水口的夹取。
1. Main body being made of high-strength Aluminium , light weight , strong rigidity and long life cycle.
  2. Using threaded components or CRG's components when to assemble.
  3. GR series of sprue gripper can choose different types of jaws to satisfy the clamping of various sprue gate.



GR20F-20-CN(CP)  
带传感器  
(With Sensor)



GR20G-20  
无传感器  
(Without Sensor)



GR20G-20-CN(CP)  
带传感器  
(With Sensor)



GR20H-20  
无传感器  
(Without Sensor)



GR20H-20-CN(CP)  
带传感器  
(With Sensor)



GR20I-20  
无传感器  
(Without Sensor)



GR20I-20-CN(CP)  
带传感器  
(With Sensor)

货号(PN)	型号(Model)	传感器(Sensor)	抓取力(F)	重量(Weight)
8.Y01361	GR20F-20-CP	PNP	80N	170g
8.Y01362	GR20F-20-CN	NPN	80N	170g
8.Y01363	GR20G-20	-	80N	131.1g
8.Y01364	GR20G-20-CP	PNP	80N	153.7g
8.Y01365	GR20G-20-CN	NPN	80N	153.7g
8.Y01366 <small>(钢制钳口Steel jaws)</small>	GR20H-20	-	80N	193.1g
8.Y01367 <small>(钢制钳口Steel jaws)</small>	GR20H-20-CP	PNP	80N	220.5g
8.Y01368 <small>(钢制钳口Steel jaws)</small>	GR20H-20-CN	NPN	80N	220.5g
8.Y01369 <small>(钢制钳口Steel jaws)</small>	GR20I-20	-	80N	191.6g
8.Y01370 <small>(钢制钳口Steel jaws)</small>	GR20I-20-CP	PNP	80N	219g
8.Y01371 <small>(钢制钳口Steel jaws)</small>	GR20I-20-CN	NPN	80N	219g

# GR20A系列

## GR20A Series

### GR20A系列

本体使用超硬铝材料, 重量轻刚性强, 寿命长。

组装时可选择螺纹安装和CRG部品安装。

#### Series GR20A

Main body being made of high-strength Aluminium, light weight, strong rigidity and long life cycle.

Using threaded components or CRG's components when to assemble.



GR20A-20  
无传感器(Without Sensor)



钻石齿  
Diamond tooth



GR20A-20-CN(CP)  
带传感器(With Sensor)

MAP-8S2P1/F (PNP)  
MAP-8S2N1/F (NPN)

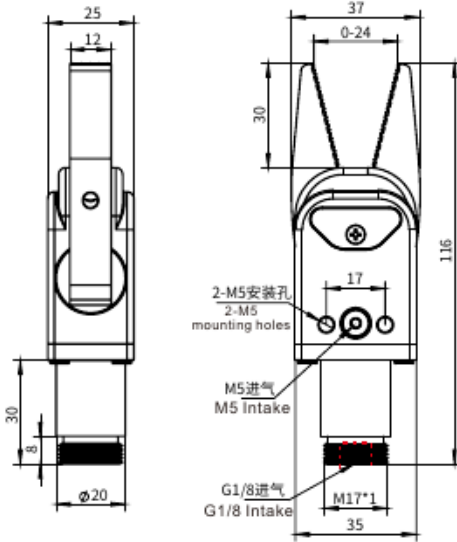

无传感器(Without Sensor)

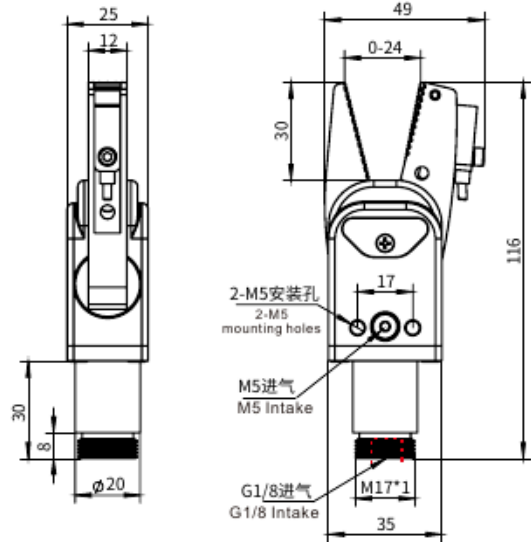

带传感器(With Sensor)

货号(PN)	型号(Model)	传感器(Sensor)	抓取力(F)	重量(Weight)
8.Y01349	GR20A-20	-	80N	112g
8.Y01350	GR20A-20-CP	PNP	80N	137g
8.Y01351	GR20A-20-CN	NPN	80N	137g

Profile、SUS Tube  
型材、钢管

Stents Module  
支架模组

Quick Changer  
快换

Grip Module  
夹具组件

Air Nipper  
气动剪刀

Vacuum Module  
真空组件

Accessory Components  
附件

# GR20B系列

## GR20B Series

### GR20B系列

本体使用超硬铝材料,重量轻刚性强,寿命长。

组装时可选择螺纹安装和CRG部品安装。

#### Series GR20B

Main body being made of high-strength Aluminium, light weight, strong rigidity and long life cycle.

Using threaded components or CRG's components when to assemble.

Profile、SUS Tube  
型材、钢管

Stents Module  
支架模组

Quick Changer  
快换

Grip Module  
夹具组件

Air Nipper  
气动剪刀

Vacuum Module  
真空组件

Accessory Components  
附件



GR20B-20  
无传感器(Without Sensor)



斜齿  
Helical tooth



MAP-8S2P1/F (PNP)  
MAP-8S2N1/F (NPN)

GR20B-20-CN(CP)  
带传感器(With Sensor)

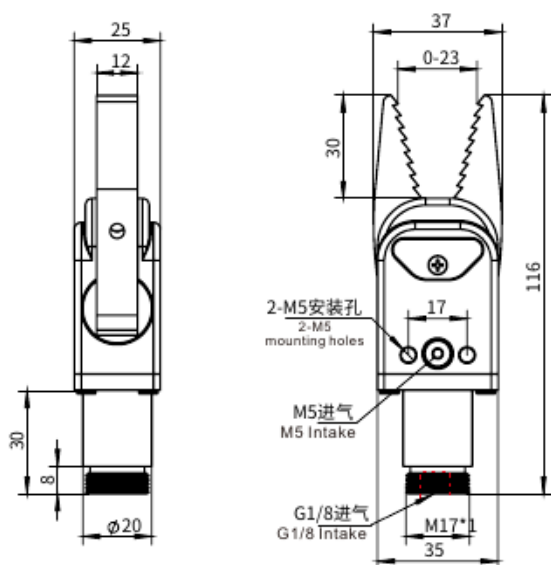

无传感器(Without Sensor)

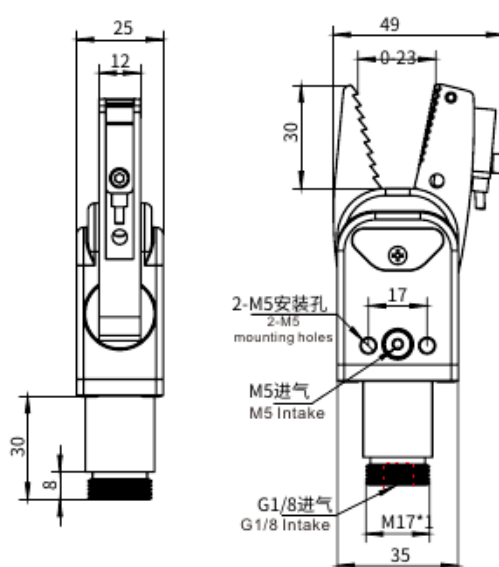

带传感器(With Sensor)

货号(PN)	型号(Model)	传感器(Sensor)	抓取力(F)	重量(Weight)
8.Y01352	GR20B-20	-	80N	112g
8.Y01353	GR20B-20-CP	PNP	80N	137g
8.Y01354	GR20B-20-CN	NPN	80N	137g

# GR20C系列

## GR20C Series

### GR20C系列

本体使用超硬铝材料,重量轻刚性强,寿命长。

组装时可选择螺纹安装和CRG部品安装。

#### Series GR20C

Main body being made of high-strength Aluminium, light weight, strong rigidity and long life cycle. Using threaded components or CRG's components when to assemble.



GR20C-20  
无传感器(Without Sensor)

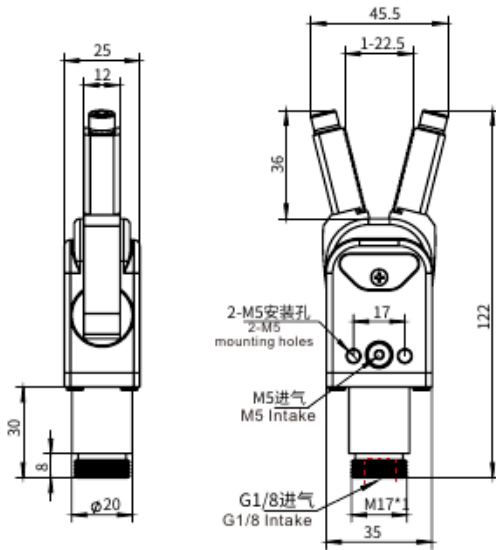

无传感器(Without Sensor)

货号(PN)	型号(Model)	传感器(Sensor)	抓取力(F)	重量(Weight)
8.Y01355	GR20C-20	-	80N	140g

Profile- SUS Tube  
型材、钢管

Stents Module  
支架模组

Quick Changer  
快换

Grip Module  
夹具组件

Air Nipper  
气动剪刀

Vacuum Module  
真空组件

Accessory Components  
附件

# GR20D系列

## GR20D Series

### GR20D系列

本体使用超硬铝材料,重量轻刚性强,寿命长。  
 组装时可选择螺纹安装和CRG部品安装。

### Series GR20D

Main body being made of high-strength Aluminium, light weight, strong rigidity and long life cycle.  
 Using threaded components or CRG's components when to assemble.



GR20D-20  
 无传感器(Without Sensor)



GR20D-20-CN(CP)  
 带传感器(With Sensor)

MAP-8S2P1/F (PNP)  
 MAP-8S2N1/F (NPN)

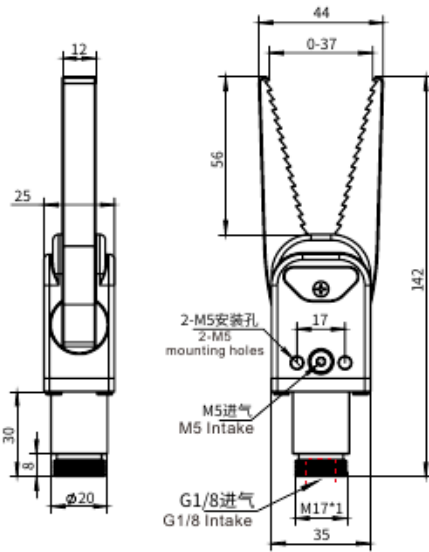

无传感器(Without Sensor)

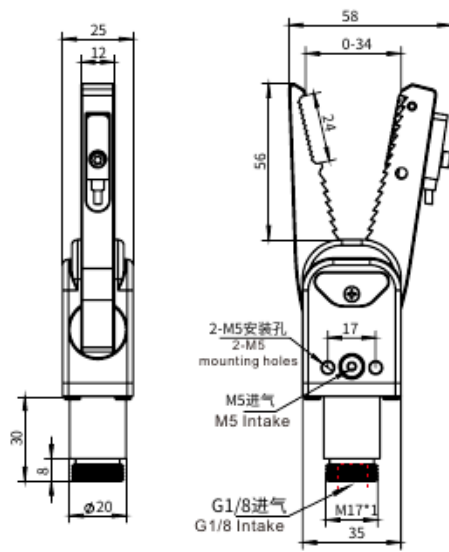

带传感器(With Sensor)

货号(PN)	型号(Model)	传感器(Sensor)	抓取力(F)	重量(Weight)
8.Y01356	GR20D-20	-	80N	149g
8.Y01357	GR20D-20-CP	PNP	80N	173.1g
8.Y01358	GR20D-20-CN	NPN	80N	173.1g

Profile, SUS Tube  
 型材、钢管

Stents Module  
 支架模组

Quick Changer  
 快换

Grip Module  
 夹具组件

Air Nipper  
 气动剪刀

Vacuum Module  
 真空组件

Accessory Components  
 附件

# GR20D-20M系列

## GR20D-20M Series

### GR20D-20M系列

可以通过调节传感器的检测位置, 来检测夹钳在夹取产品时是否到位。  
 可以实现在自动化生产中的闭环功能。

#### Series GR20D-20M

The position of the sensor can be adjusted to detect whether the clamp is in place when the product is clamped.  
 The closed-loop function can be realized in automatic production.



GR20D-20M  
 可选传感器(Optional sensors)

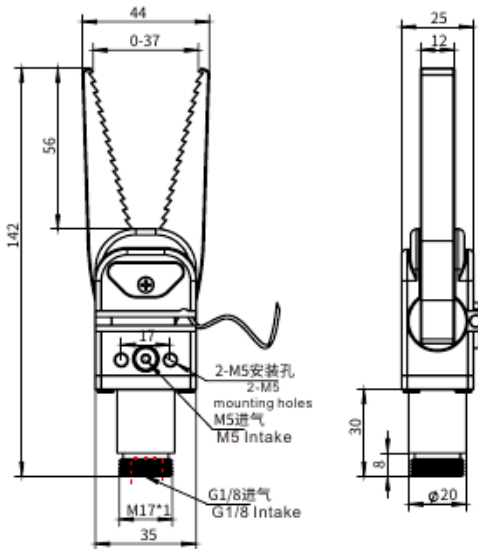

可选传感器(Optional sensors)

货号(PN)	型号(Model)	传感器(Sensor)	抓取力(F)	重量(Weight)
8.Y01400	GR20D-20M	-	80N	163.6g
8.Y01401	GR20D-20M-CP	PNP	80N	170g
8.Y01402	GR20D-20M-CN	NPN	80N	170g

Profile- SUS Tube  
 型材、钢管

Stents Module  
 支架模组

Quick Changer  
 快换

Grip Module  
 夹具组件

Air Nipper  
 气动剪刀

Vacuum Module  
 真空组件

Accessory Components  
 附件

# GR20E系列

## GR20E Series

### GR20E系列

本体使用超硬铝材料,重量轻刚性强,寿命长。

组装时可选择螺纹安装和CRG部品安装。

### Series GR20E

Main body being made of high-strength Aluminium , light weight , strong rigidity and long life cycle.  
Using threaded components or CRG's components when to assemble.



GR20E-20  
无传感器(Without Sensor)

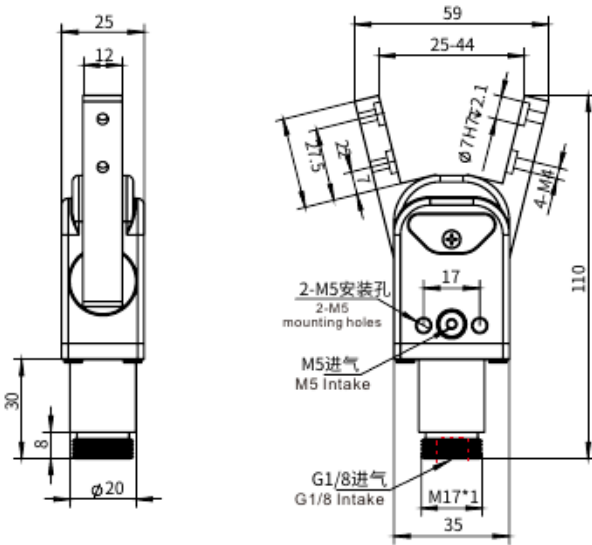

带传感器(With Sensor)

货号(PN)	型号(Model)	传感器(Sensor)	抓取力(F)	重量(Weight)
8.Y01359	GR20E-20	-	80N	129g

Profile、SUS Tube  
型材、钢管

Stents Module  
支架模组

Quick Changer  
快换

Grip Module  
夹具组件

Air Nipper  
气动剪刀

Vacuum Module  
真空组件

Accessory Components  
附件

# GR20F系列

## GR20F Series

### GR20F系列

本体使用超硬铝材料,重量轻刚性强,寿命长。

组装时可选择螺纹安装和CRG部品安装。

#### Series GR20F

Main body being made of high-strength Aluminium , light weight , strong rigidity and long life cycle.  
Using threaded components or CRG's components when to assemble.



GR20F-20  
无传感器(Without Sensor)



货号(PN)	4.Y00513
型号(Model)	SIL-1026
重量(Weight)	1.7g



GR20F-20-CN(CP)  
带传感器(With Sensor)

MAP-8S2P1/F (PNP)  
MAP-8S2N1/F (NPN)

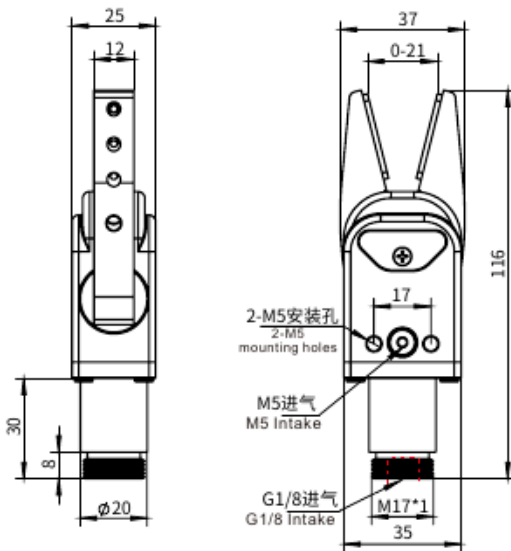

无传感器(Without Sensor)

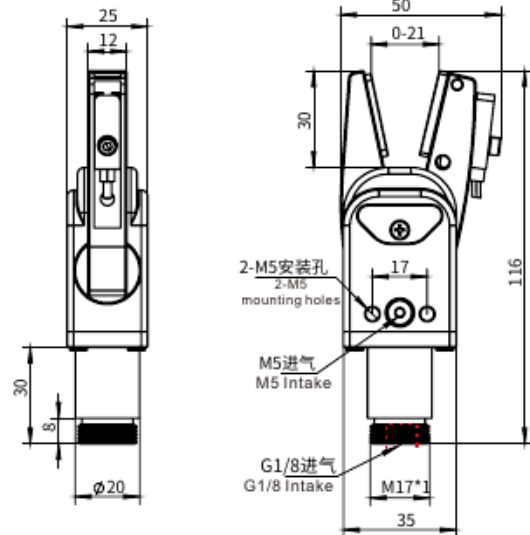

带传感器(With Sensor)

货号(PN)	型号(Model)	传感器(Sensor)	抓取力(F)	重量(Weight)
8.Y01360	GR20F-20	-	80N	128g
8.Y01361	GR20F-20-CP	PNP	80N	170g
8.Y01362	GR20F-20-CN	NPN	80N	170g

Profile- SUS Tube  
型材、钢管

Stents Module  
支架模组

Quick Changer  
快换

Grip Module  
夹具组件

Air Nipper  
气动剪刀

Vacuum Module  
真空组件

Accessory Components  
附件

# GR20G系列

## GR20G Series

### GR20G系列

本体使用超硬铝材料,重量轻刚性强,寿命长。

组装时可选择螺纹安装和CRG部品安装。

#### Series GR20G

Main body being made of high-strength Aluminium , light weight , strong rigidity and long life cycle.  
Using threaded components or CRG's components when to assemble.



GR20G-20  
无传感器(Without Sensor)



GR20G-20-CN(CP)  
带传感器(With Sensor)

MAP-8S2P1/F (PNP)  
MAP-8S2N1/F (NPN)

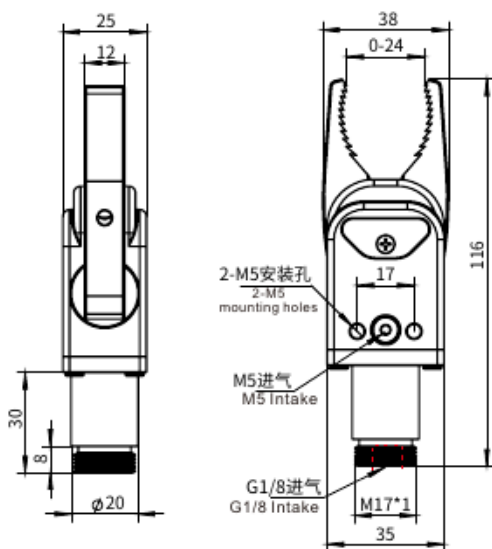

无传感器(Without Sensor)

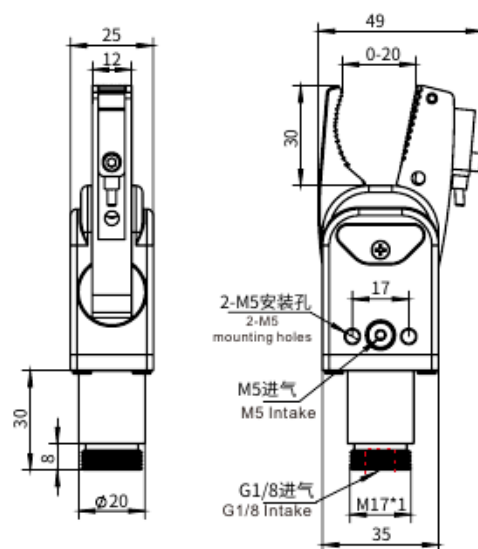

带传感器(With Sensor)

货号(PN)	型号(Model)	传感器(Sensor)	抓取力(F)	重量(Weight)
8.Y01363	GR20G-20	-	80N	131.1g
8.Y01364	GR20G-20-CP	PNP	80N	153.7g
8.Y01365	GR20G-20-CN	NPN	80N	153.7g

Profile, SUS Tube  
型材、钢管

Stents Module  
支架模组

Quick Changer  
快换

Grip Module  
夹具组件

Air Nipper  
气动剪刀

Vacuum Module  
真空组件

Accessory Components  
附件

# GR20H系列

## GR20H Series

### GR20H系列

本体使用超硬铝材料,重量轻刚性强,寿命长。

组装时可选择螺纹安装和CRG部品安装。

#### Series GR20H

Main body being made of high-strength Aluminium , light weight , strong rigidity and long life cycle.

Using threaded components or CRG's components when to assemble.



GR20H-20  
无传感器(Without Sensor)



钢制钳口  
Steel jaw



GR20H-20-CN(CP)  
带传感器(With Sensor)



钢制探头  
Steel probe

MAP-8S1.5P1/F CP  
MAP-8S1.5P1/F CN

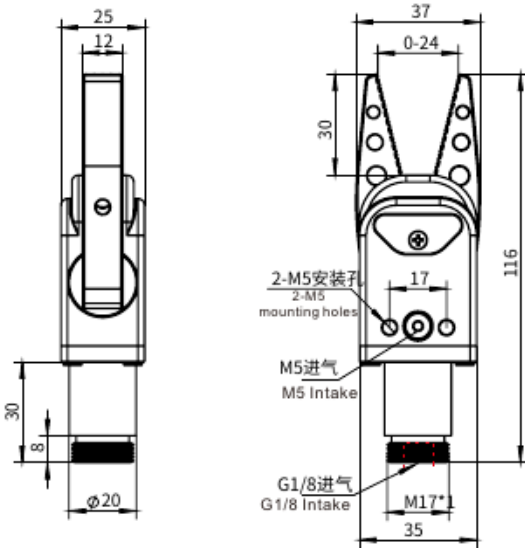

无传感器(Without Sensor)

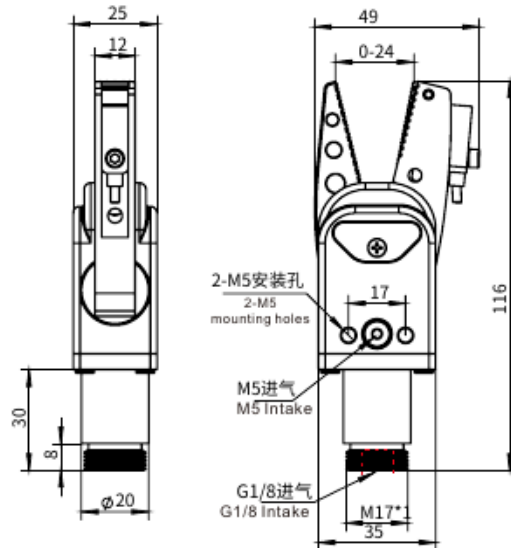

带传感器(With Sensor)

货号(PN)	型号(Model)	传感器(Sensor)	抓取力(F)	重量(Weight)
8.Y01366	GR20H-20	-	80N	193.1g
8.Y01367	GR20H-20-CP	PNP	80N	220.5g
8.Y01368	GR20H-20-CN	NPN	80N	220.5g

Profile- SUS Tube  
型材、钢管

Stents Module  
支架模组

Quick Changer  
快换

Grip Module  
夹具组件

Air Nipper  
气动剪刀

Vacuum Module  
真空组件

Accessory Components  
附件

# GR20I系列

## GR20I Series

### GR20I系列

本体使用超硬铝材料,重量轻刚性强,寿命长。

组装时可选择螺纹安装和CRG部品安装。

#### Series GR20I

Main body being made of high-strength Aluminium, light weight, strong rigidity and long life cycle. Using threaded components or CRG's components when to assemble.



钢制钳口  
Steel jaw

GR20I-20  
无传感器(Without Sensor)



钢制探头  
Steel probe

MAP-8S1.5P1/F CP  
MAP-8S1.5P1/F CN

GR20I-20-CN(CP)  
带传感器(With Sensor)

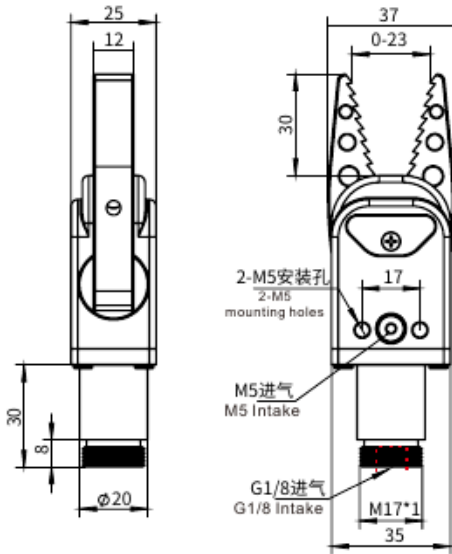

无传感器(Without Sensor)

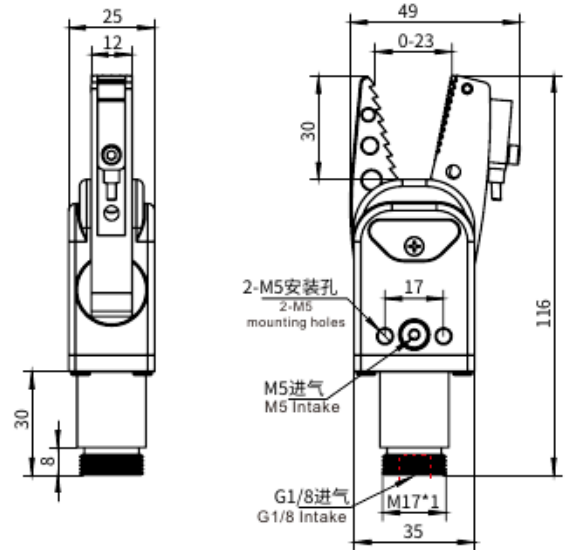

带传感器(With Sensor)

货号(PN)	型号(Model)	传感器(Sensor)	抓取力(F)	重量(Weight)
8.Y01369	GR20I-20	-	80N	191.6g
8.Y01370	GR20I-20-CP	PNP	80N	219.1g
8.Y01371	GR20I-20-CN	NPN	80N	219.1g

## 水口夹具 Sprue Gripper

1. 活塞孔: 12mm
2. 打开弹簧的单一动作
3. 超硬铝材料, 重量轻刚性强, 寿命长
4. 通过真空负压进行抓持检测



GRP10B-12  
无传感器  
(Without Sensor)



GRP10B-12-CN(CP)  
带传感器  
(With Sensor)



GRP10(12)C-12-SV  
真空检测  
(Vacuum Testing)



GRP10D-12  
无传感器  
(Without Sensor)



GRP10(12)F-12-SV  
真空检测  
(Vacuum Testing)



GRP10M-12-CN(CP)  
带传感器  
(With Sensor)



GRP10N-12  
无传感器  
(Without Sensor)

货号(PN)	型号(Model)	传感器(Sensor)	真空检测(Vacuum Testing)	抓取力(F)	重量(Weight)
8.Y01379	GRP10B-12	-	-	80N	112g
8.Y00368	GRP10B-12-CP	PNP	-	80N	137g
8.Y01017	GRP10B-12-CN	NPN	-	80N	137g
8.Y01224	GRP10C-12-SV	-	√	80N	112g
8.Y01288	GRP12C-12-SV	-	√	80N	137g
8.Y01253	GRP10D-12	-	-	80N	137g
8.Y01287	GRP10F-12-SV	-	√	80N	140g
8.Y01285	GRP12F-12-SV	-	√	80N	149g
8.Y01293	GRP10M-12-CN	NPN	-	80N	173.1g
8.Y01119	GRP10M-12-CP	PNP	-	80N	173.1g
8.Y01108	GRP10N-12	-	-	80N	163.6g

Profile- SUS Tube  
型材、钢管

Stents Module  
支架模组

Quick Changer  
快换

Grip Module  
夹具组件

Air Nipper  
气动剪刀

Vacuum Module  
真空组件

Accessory Components  
附件

# GRP10B-12系列

## GRP10B-12 Series

- 1. 活塞孔: 12mm
- 2. 打开弹簧的单一动作
- 3. 超硬铝材料, 重量轻刚性强, 寿命长

1. Piston bore: 12 mm

2. Single-action spring release

3. Made of ultra-hard aluminum: lightweight, highly rigid, and long-lasting



GRP10B-12  
无传感器(Without Sensor)



GRP10B-12-CP(CN)  
带传感器(With Sensor)

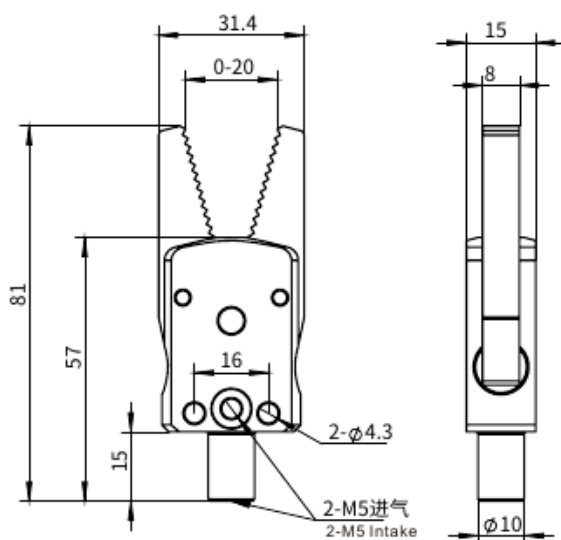

无传感器(Without Sensor)

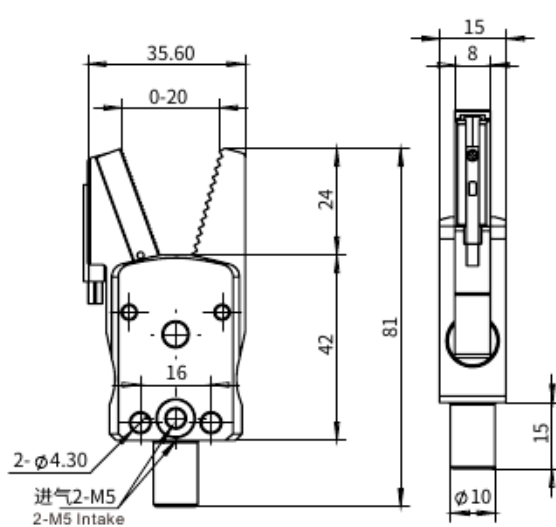

带传感器(With Sensor)

货号(PN)	型号(Model)	传感器(Sensor)	抓取力(F)	重量(Weight)
8.Y01379	GRP10B-12	-	80N	51g
8.Y00368	GRP10B-12-CP	PNP	80N	86g
8.Y01017	GRP10B-12-CN	NPN	80N	86g

Profile, SUS Tube  
型材、钢管

Stents Module  
支架模组

Quick Changer  
快换

Grip Module  
夹具组件

Air Nipper  
气动剪刀

Vacuum Module  
真空组件

Accessory Components  
附件

# GRP10/12C-12-SV系列 **NEW**

## GRP10/12C-12-SV Series

- |                 |   |
|-----------------|---|
| 1. 活塞孔: 12mm    | 1. Piston bore: 12 mm                         |
| 2. 打开弹簧的单一动作    | 2. Single-action spring opening               |
| 3. 通过真空负压进行抓持检测 | 3. Gripping and inspection via vacuum suction |



GRP10/12C-12-SV  
真空检测(Vacuum Testing)

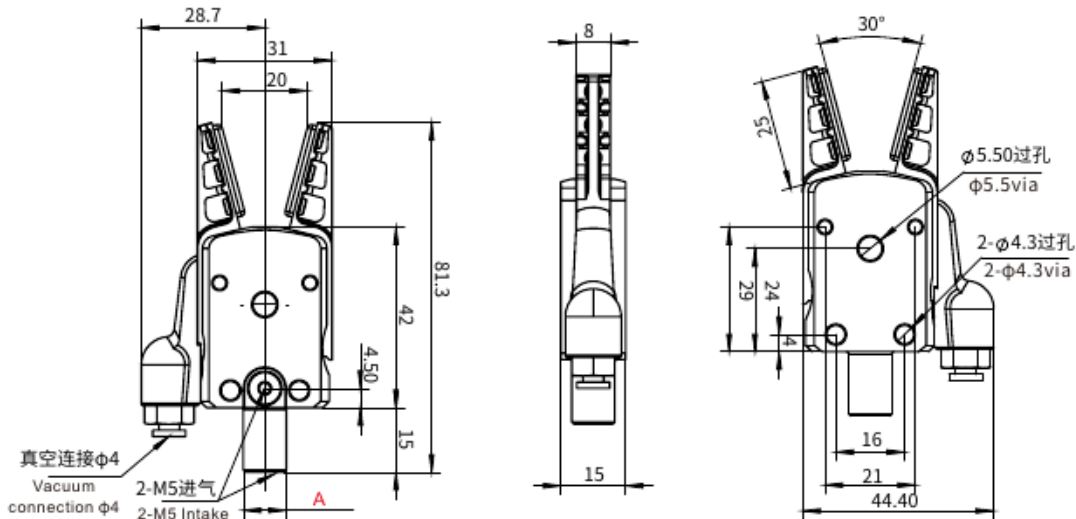
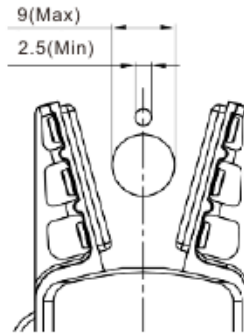

真空检测(Vacuum Testing)

货号(PN)	型号(Model)	真空检测(Vacuum Testing)	A	抓取力(F)	重量(Weight)
8.Y01224	GRP10C-12-SV	√	φ10	80N	52g
8.Y01288	GRP12C-12-SV	√	φ12	80N	54g

Profile- SUS Tube  
型材、钢管

Stents Module  
支架模组

Quick Changer  
快换

Grip Module  
夹具组件

Air Nipper  
气动剪刀

Vacuum Module  
真空组件

Accessory Components  
附件

# GRP10D-12系列

NEW

## GRP10D-12 Series

- |                       |  |
|-----------------------|--|
| 1. 活塞孔: 12mm          | 1. Piston bore: 12 mm  |
| 2. 打开弹簧的单一动作          | 2. Single-action spring release  |
| 3. 超硬铝材料, 重量轻刚性强, 寿命长 | 3. Ultra-hard aluminum material: lightweight, high rigidity, and long service life |



GRP10D-12  
无传感器(Without Sensor)

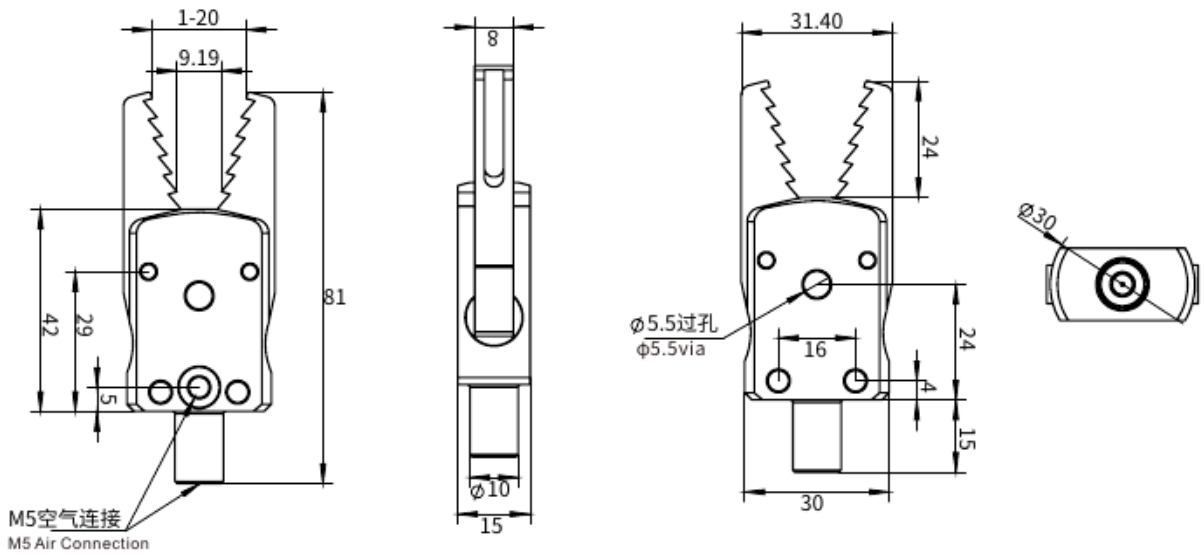

无传感器(Without Sensor)

货号(PN)	型号(Model)	抓取力(F)	重量(Weight)
8.Y01253	GRP10D-12	80N	48g

Profile, SUS Tube  
型材、钢管

Stents Module  
支架模组

Quick Changer  
快换

Grip Module  
夹具组件

Air Nipper  
气动剪刀

Vacuum Module  
真空组件

Accessory Components  
附件

# GRP10/12F-12-SV系列 **NEW**

## GRP10/12F-12-SV Series

- |                 |   |
|-----------------|---|
| 1. 活塞孔: 12mm    | 1. Piston bore: 12 mm                         |
| 2. 打开弹簧的单一动作    | 2. Single-action spring opening               |
| 3. 通过真空负压进行抓持检测 | 3. Gripping and inspection via vacuum suction |



GRP10/12F-12-SV  
真空检测(Vacuum Testing)

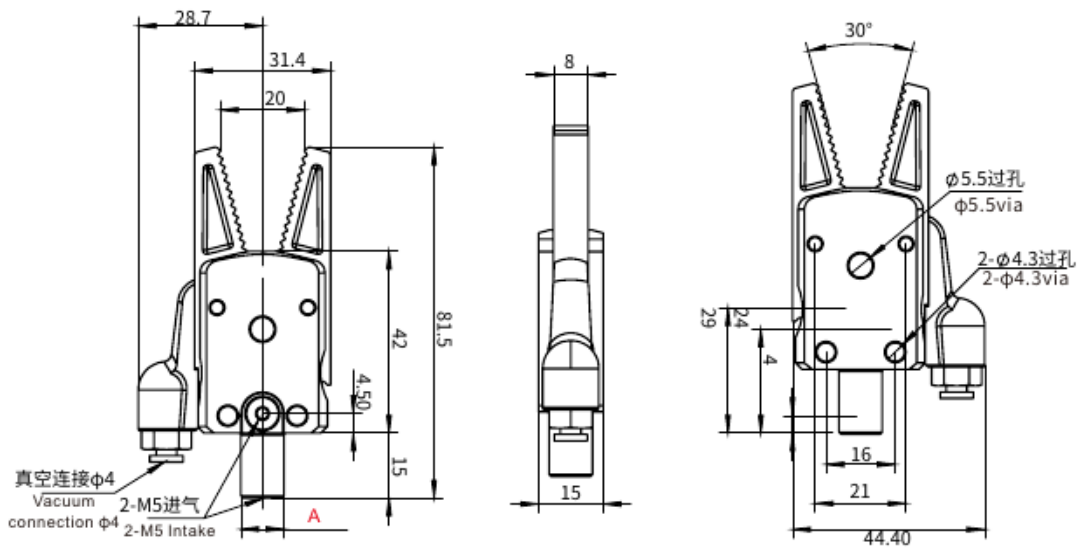
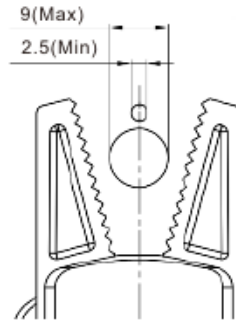

真空检测(Vacuum Testing)

货号(PN)	型号(Model)	真空检测(Vacuum Testing)	A	抓取力(F)	重量(Weight)
8.Y01287	GRP10F-12-SV	√	$\phi 10$	80N	55g
8.Y01285	GRP12F-12-SV	√	$\phi 12$	80N	57g

Profile- SUS Tube  
型材、钢管

Stents Module  
支架模组

Quick Changer  
快换

Grip Module  
夹具组件

Air Nipper  
气动剪刀

Vacuum Module  
真空组件

Accessory Components  
附件

# GRP10M-12系列

## GRP10M-12 Series

- |                       |  |
|-----------------------|--|
| 1. 活塞孔: 12mm          | 1. Piston bore: 12 mm  |
| 2. 打开弹簧的单一动作          | 2. Single-action spring release  |
| 3. 超硬铝材料, 重量轻刚性强, 寿命长 | 3. Ultra-hard aluminum material: lightweight, high rigidity, and long service life |



钢制夹头  
Steel collet

GRP10M-12-CP(CN)  
传感器(With Sensor)

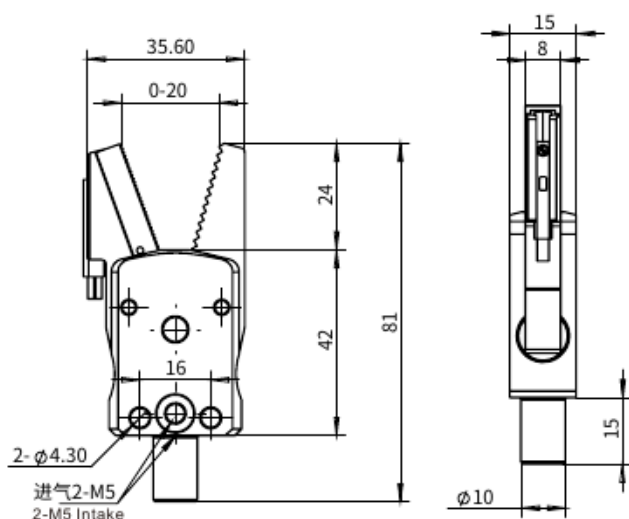

带传感器(With Sensor)

货号(PN)	型号(Model)	传感器(Sensor)	抓取力(F)	重量(Weight)
8.Y01293	GRP10M-12-CN	NPN	80N	87g
8.Y01119	GRP10M-12-CP	PNP	80N	87g

Profile, SUS Tube  
型材、钢管

Stents Module  
支架模组

Quick Changer  
快换

Grip Module  
夹具组件

Air Nipper  
气动剪刀

Vacuum Module  
真空组件

Accessory Components  
附件

# GRP10N-12系列

NEW

## GRP10N-12 Series

- |                       |  |
|-----------------------|--|
| 1. 活塞孔: 12mm          | 1. Piston bore: 12 mm  |
| 2. 打开弹簧的单一动作          | 2. Single-action spring release  |
| 3. 超硬铝材料, 重量轻刚性强, 寿命长 | 3. Ultra-hard aluminum material: lightweight, high rigidity, and long service life |



GRP10N-12  
无传感器(Without Sensor)

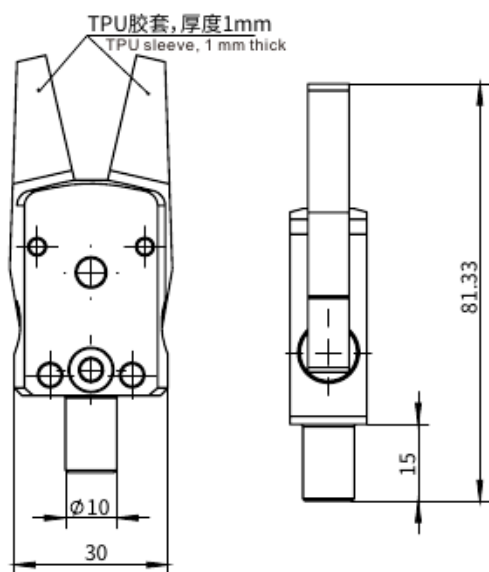

无传感器(Without Sensor)

Profile- SUS Tube  
型材、钢管

Stents Module  
支架模组

Quick Changer  
快换

Grip Module  
夹具组件

Air Nipper  
气动剪刀

Vacuum Module  
真空组件

Accessory Components  
附件

货号(PN)	型号(Model)	抓取力(F)	重量(Weight)
8.Y01108	GRP10N-12	80N	48g

## 水口夹具 Sprue Gripper

Profile, SUS Tube  
型材、钢管

Stents Module  
支架模组

Quick Changer  
快换

Grip Module  
夹具组件

Air Nipper  
气动剪刀

Vacuum Module  
真空组件

Accessory Components  
附件

1. 双动作或弹簧开启 (-NO).
2. 不同重量和尺寸均具有很高的夹紧力。
3. 不同的紧固选项。
4. 可选的磁传感器。

1. Double acting or spring open (-NO).
2. Very high gripping force related to the weight and dimensions.
3. Different options for fastening.
4. Optional magnetic sensors.

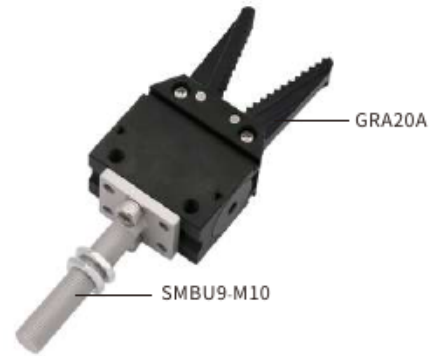

GRA20A  
无传感器  
(Without Sensor)



GRA20A-CN(CP)  
带传感器  
(With Sensor)



GRA20C-CN(CP)  
带传感器  
(With Sensor)

货号(PN)	型号(Model)	传感器(Sensor)	抓取力(F)	重量(Weight)
8.Y00391	GRA20A	-	80N	110g
8.Y00392	GRA20A-CP	PNP	80N	115g
8.Y00393	GRA20A-CN	NPN	80N	115g
8.Y01076	GRA20B	-	80N	126g
8.Y00434	GRA20C-CP	PNP	80N	135g
8.Y00435	GRA20C-CN	NPN	80N	135g

# GRA20A系列

## GRA20A Series

1. 双动作或弹簧开启 (-NO)。
  2. 不同重量和尺寸均具有很高的夹紧力。
  3. 不同的紧固选项。
  4. 可选的磁传感器。
1. Double acting or spring open (-NO).
  2. Very high gripping force related to the weight and dimensions.
  3. Different options for fastening.
  4. Optional magnetic sensors.



GRA20A  
无传感器(Without Sensor)

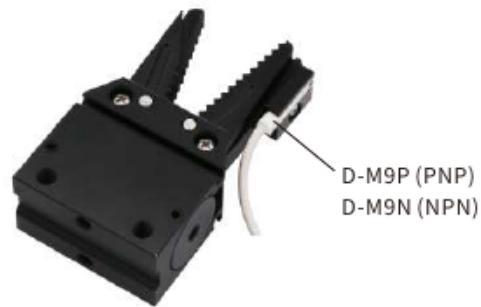

GRA20A-CN(CP)  
带传感器(With Sensor)

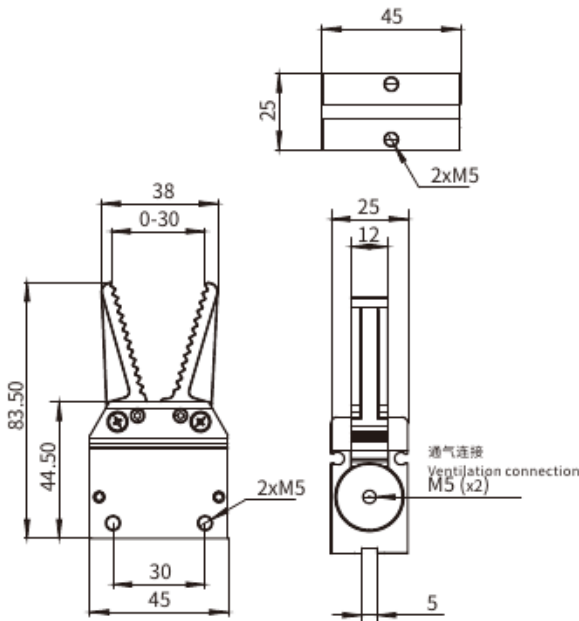

无传感器(Without Sensor)

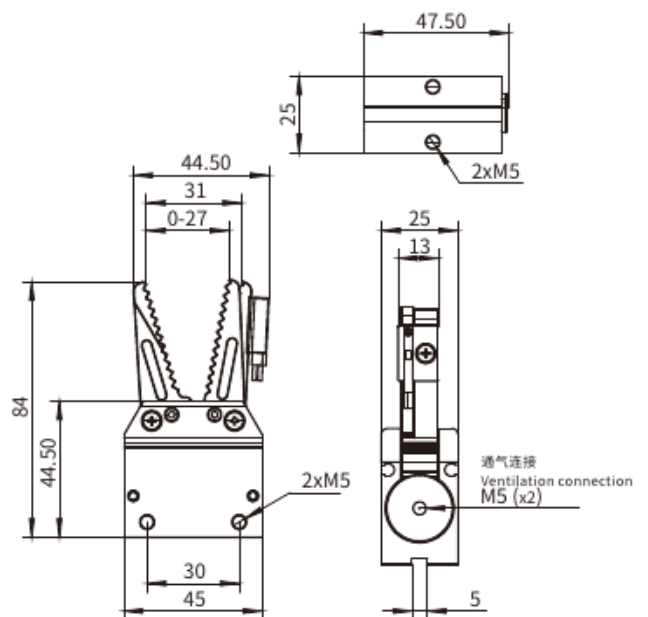

带传感器(With Sensor)

货号(PN)	型号(Model)	传感器(Sensor)	抓取力(F)	重量(Weight)
8.Y00391	GRA20A	-	80N	110g
8.Y00392	GRA20A-CP	PNP	80N	115g
8.Y00393	GRA20A-CN	NPN	80N	115g

# GRA20B系列

## GRA20B Series

Profile, SUS Tube  
型材、钢管

Stents Module  
支架模组

Quick Changer  
快换

Grip Module  
夹具组件

Air Nipper  
气动剪刀

Vacuum Module  
真空组件

Accessory Components  
附件

1. 双动作或弹簧开启(-NO)
  2. 钳口夹持宽度增加,增大夹持面积。
  3. 钳口附带倒钩,夹持不易脱落。
  4. 不同的紧固选项。
1. Dual action or spring open (-NO)
  2. Jaws with increased clamping width to increase the clamping area.
  3. Jaws with barbed hooks, not easy to fall off.
  4. Different fastening options.

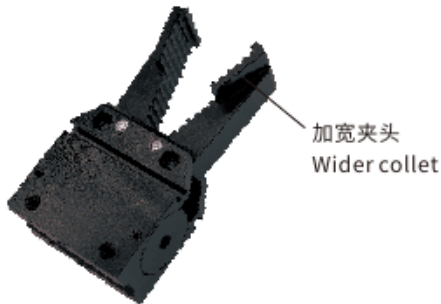

GRA20B  
无传感器(Without Sensor)

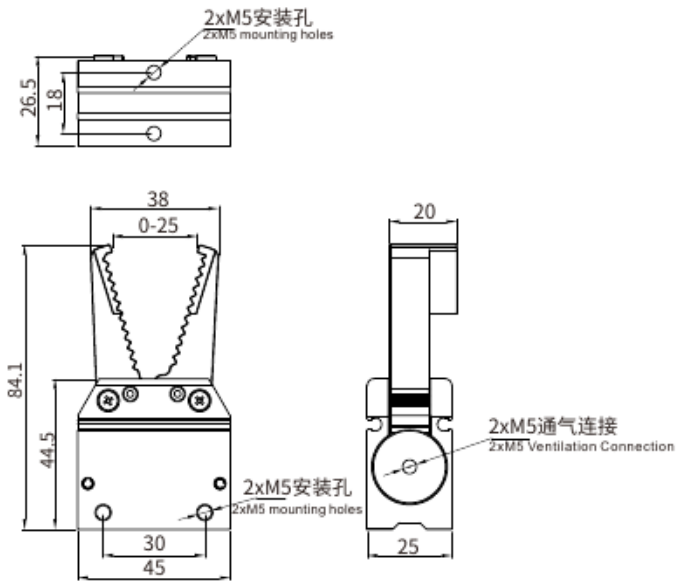

无传感器(Without Sensor)

货号(PN)	型号(Model)	传感器(Sensor)	抓取力(F)	重量(Weight)
8.Y01076	GRA20B	-	80N	126g

# GRA20C系列

## GRA20C Series

1. 双动作或弹簧开启 (-NO).
  2. 不同重量和尺寸均具有很高的夹紧力。
  3. 不同的紧固选项。
  4. 可选的磁传感器。
1. Double acting or spring open (-NO).
  2. Very high gripping force related to the weight and dimensions.
  3. Different options for fastening.
  4. Optional magnetic sensors.

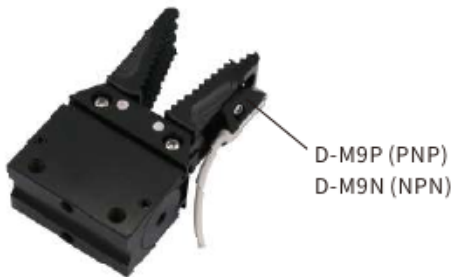

GRA20C-CN(CP)  
带传感器(With Sensor)

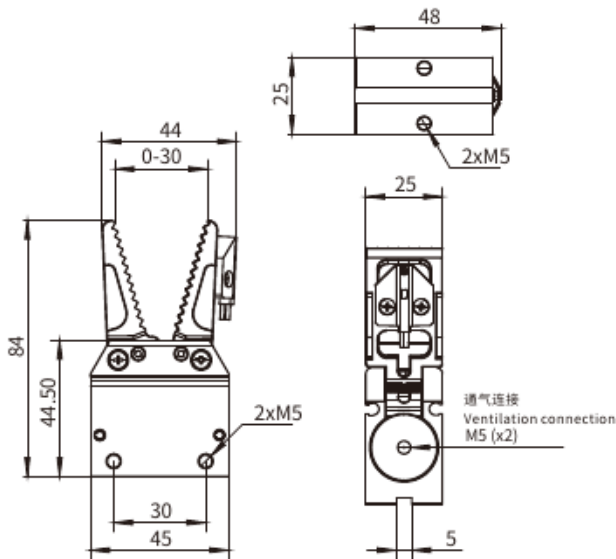

带传感器(With Sensor)

货号(PN)	型号(Model)	传感器(Sensor)	抓取力(F)	重量(Weight)
8.Y00434	GRA20C-CP	PNP	80N	135g
8.Y00435	GRA20C-CN	NPN	80N	135g

## 水口夹具 Sprue Gripper

1. 本体使用超硬铝材料,重量轻刚性强,寿命长。
  2. 组装时可选择螺纹安装和CRG部品安装。
  3. GR系列水口夹可选择不同的夹头形状,满足多种水口的夹取。
1. Main body being made of high-strength Aluminium , light weight , strong rigidity and long life cycle.
  2. Using threaded components or CRG's components when to assemble.
  3. GR series of sprue gripper can choose different types of jaws to satisfy the clamping of various sprue gate.



GRT20A  
无传感器  
(Without Sensor)



GRT20B  
无传感器  
(Without Sensor)



GRT20C  
无传感器  
(Without Sensor)



GRT20E  
无传感器  
(Without Sensor)



GRT20A-CN(CP)  
带传感器  
(With Sensor)



GRT20B-CN(CP)  
带传感器  
(With Sensor)



GRT20D  
无传感器  
(Without Sensor)



GRT20E-CN(CP)  
带传感器  
(With Sensor)

货号(PN)	型号(Model)	信号开关(Switch type)	抓取力(F)	重量(Weight)
8.Y00257	GRT20A	-	100N	111g
8.Y00258	GRT20A-CN	NPN	100N	130g
8.Y00259	GRT20A-CP	PNP	100N	130g
8.Y00279	GRT20B	-	100N	157.5g
8.Y00281	GRT20B-CN	NPN	100N	164g
8.Y00282	GRT20B-CP	PNP	100N	164g
8.Y00316	GRT20C	-	100N	144g
8.Y00317	GRT20D	-	100N	160g
8.Y01004	GRT20D-CP	PNP	100N	145g
8.Y00458	GRT20D-CN	NPN	100N	145g
8.Y00318	GRT20E	-	100N	161g
8.Y00339	GRT20E-CN	NPN	100N	165g
8.Y00340	GRT20E-CP	PNP	100N	165g
8.Y01008	GRT20F	-	100N	111g

Profile, SUS Tube  
型材、钢管

Stents Module  
支架模组

Quick Changer  
快换

Grip Module  
夹具组件

Air Nipper  
气动剪刀

Vacuum Module  
真空组件

Accessory Components  
附件

# GRT20A系列

## GRT20A Series

1. 本体使用超硬铝材料, 重量轻刚性强, 寿命长。
2. 组装时可选择螺纹安装和CRG部品安装。
3. GR系列水口夹可选择不同的夹头形状, 满足多种水口的夹取。
1. Main body being made of high-strength Aluminium , light weight , strong rigidity and long life cycle.
2. Using threaded components or CRG's components when to assemble.
3. GR series of sprue gripper can choose different types of jaws to satisfy the clamping of various sprue gate.



GRT20A  
无传感器(Without Sensor)



GRT20A-CN(CP)  
带传感器(With Sensor)

MAP-8S2P1/F (PNP)  
MAP-8S2N1/F (NPN)

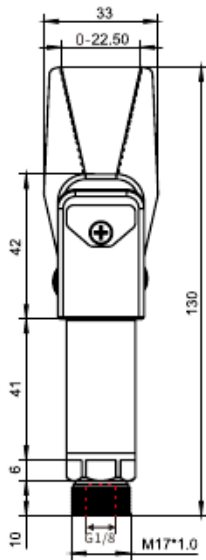

无传感器(Without Sensor)

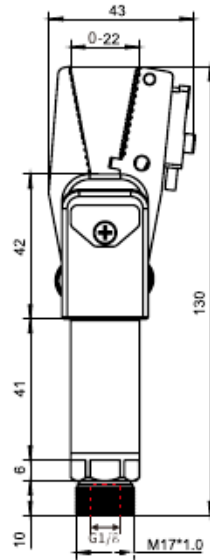
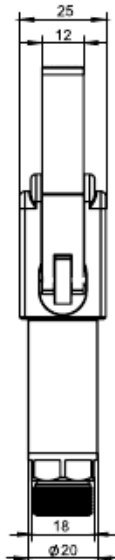

带传感器(With Sensor)

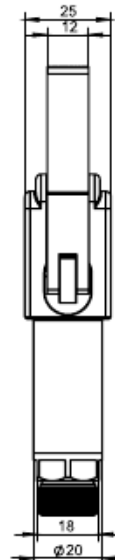

货号(PN)	型号(Model)	传感器(Sensor)	抓取力(F)	重量(Weight)
8.Y00257	GRT20A	-	100N	111g
8.Y00258	GRT20A-CN	NPN	100N	130g
8.Y00259	GRT20A-CP	PNP	100N	130g

# GRT20B系列

## GRT20B Series

Profile, SUS Tube  
型材、钢管

Stents Module  
支架模组

Quick Changer  
快换

Grip Module  
夹具组件

Air Nipper  
气动剪刀

Vacuum Module  
真空组件

Accessory Components  
附件

1. 本体使用超硬铝材料,重量轻刚性强,寿命长。
  2. 组装时可选择螺纹安装和CRG部品安装。
  3. GR系列水口夹可选择不同的夹头形状,满足多种水口的夹取。
1. Main body being made of high-strength Aluminium , light weight , strong rigidity and long life cycle.
  2. Using threaded components or CRG's components when to assemble.
  3. GR series of sprue gripper can choose different types of jaws to satisfy the clamping of various sprue gate.



GRT20B  
无传感器(Without Sensor)



GRT20B-CN(CP)  
带传感器(With Sensor)

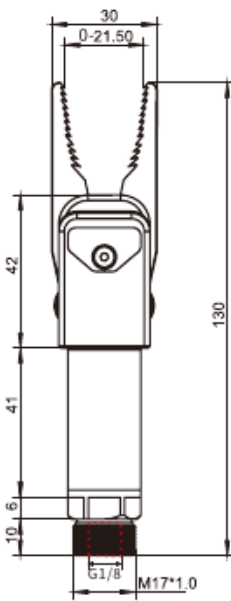

无传感器(Without Sensor)

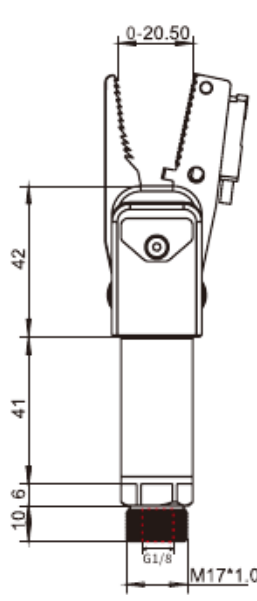

带传感器(With Sensor)

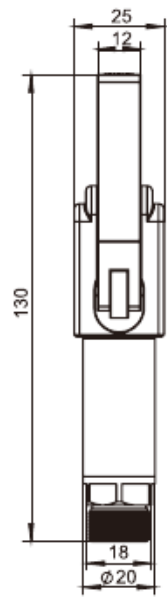

货号(PN)	型号(Model)	传感器(Sensor)	抓取力(F)	重量(Weight)
8.Y00279	GRT20B	-	100N	157.5g
8.Y00281	GRT20B-CN	NPN	100N	164g
8.Y00282	GRT20B-CP	PNP	100N	164g

# GRT20C系列

## GRT20C Series

1. 本体使用超硬铝材料, 重量轻刚性强, 寿命长。
2. 组装时可选择螺纹安装和CRG部品安装。
3. GR系列水口夹可选择不同的夹头形状, 满足多种水口的夹取。
1. Main body being made of high-strength Aluminium , light weight , strong rigidity and long life cycle.
2. Using threaded components or CRG's components when to assemble.
3. GR series of sprue gripper can choose different types of jaws to satisfy the clamping of various sprue gate.



GRT20C  
无传感器(Without Sensor)

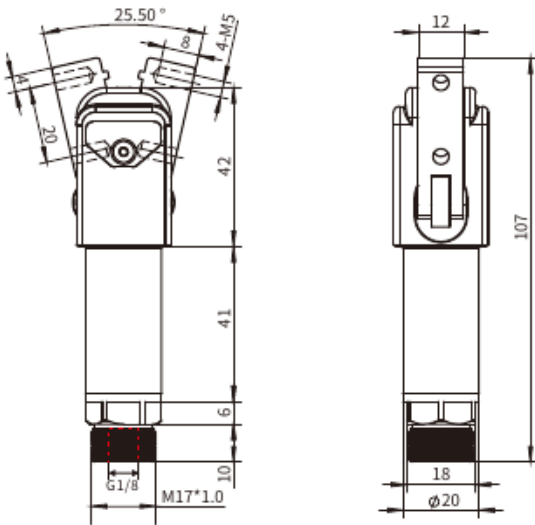

无传感器(Without Sensor)

货号(PN)	型号(Model)	传感器(Sensor)	抓取力(F)	重量(Weight)
8.Y00316	GRT20C	-	100N	144g

Profile- SUS Tube  
型材、钢管

Stents Module  
支架模组

Quick Changer  
快换

Grip Module  
夹具组件

Air Nipper  
气动剪刀

Vacuum Module  
真空组件

Accessory Components  
附件

# GRT20D系列

## GRT20D Series

1. 本体使用超硬铝材料,重量轻刚性强,寿命长。
  2. 组装时可选择螺纹安装和CRG部品安装。
  3. GR系列水口夹可选择不同的夹头形状,满足多种水口的夹取。
1. Main body being made of high-strength Aluminium , light weight , strong rigidity and long life cycle.
  2. Using threaded components or CRG's components when to assemble.
  3. GR series of sprue gripper can choose different types of jaws to satisfy the clamping of various sprue gate.



GRT20D  
无传感器(Without Sensor)



GRT20D-CN(CP)  
带传感器(With Sensor)

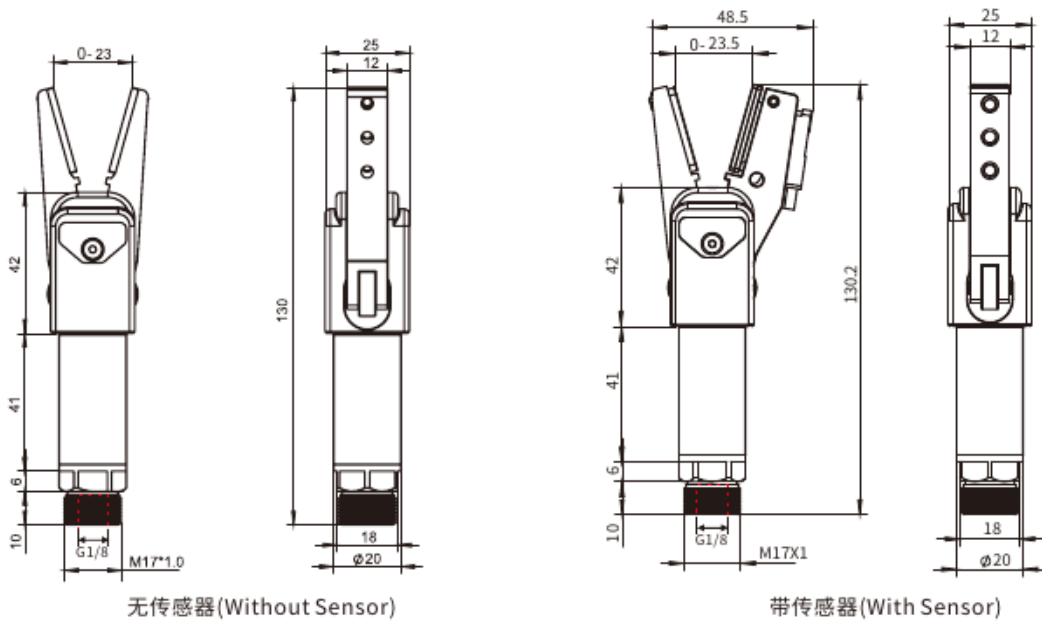

货号(PN)	型号(Model)	传感器(Sensor)	抓取力(F)	重量(Weight)
8.Y00317	GRT20D	-	100N	160g
8.Y01004	GRT20D-CP	PNP	100N	145g
8.Y00458	GRT20D-CN	NPN	100N	145g

Profile, SUS Tube  
型材、钢管

Stents Module  
支架模组

Quick Changer  
快换

Grip Module  
夹具组件

Air Nipper  
气动剪刀

Vacuum Module  
真空组件

Accessory Components  
附件

# GRT20E系列

## GRT20ESeries

1. 本体使用超硬铝材料, 重量轻刚性强, 寿命长。
2. 组装时可选择螺纹安装和CRG部品安装。
3. GR系列水口夹可选择不同的夹头形状, 满足多种水口的夹取。
1. Main body being made of high-strength Aluminium , light weight , strong rigidity and long life cycle.
2. Using threaded components or CRG's components when to assemble.
3. GR series of sprue gripper can choose different types of jaws to satisfy the clamping of various sprue gate.



GRT20E  
无传感器(Without Sensor)



GRT20E-CN(CP)  
带传感器(With Sensor)

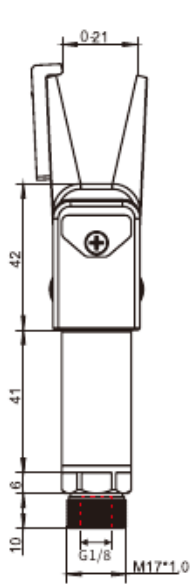

无传感器(Without Sensor)

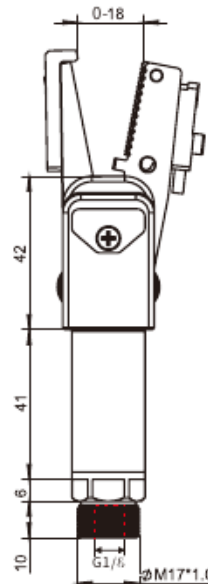
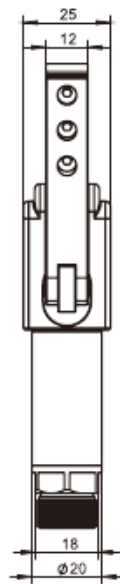

带传感器(With Sensor)

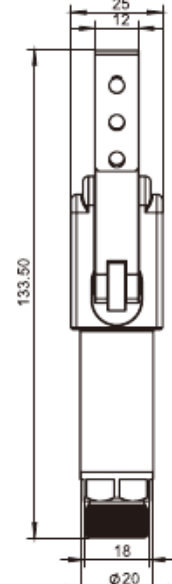

货号(PN)	型号(Model)	传感器(Sensor)	抓取力(F)	重量(Weight)
8.Y00318	GRT20E	-	100N	161g
8.Y00339	GRT20E-CN	NPN	100N	165g
8.Y00340	GRT20E-CP	PNP	100N	165g

# GRT20F系列

## GRT20F Series

Profile, SUS Tube  
型材、钢管

Stents Module  
支架模组

Quick Changer  
快换

Grip Module  
夹具组件

Air Nipper  
气动剪刀

Vacuum Module  
真空组件

Accessory Components  
附件

1. 水口夹夹住产品时, 阻挡件转动堵住真空检测件的气道, 使得外部检测器检测到, 通过这种结构检测水口夹是否夹持产品, 可靠性较高。

2. 缸体内设有第一复位弹簧, 阻挡件的A面设有第三复位弹簧, 上夹爪和下夹爪之间设有第三复位弹簧, 使得水口夹放下夹持物品时, 活塞快速复位。

3. 真空检测件的气道出口处设有软垫, 能够增强阻挡件与真空检测件之间的气密性, 同时能避免硬性材质抵接时的磨损。

1. When the nozzle clamps the product, the baffle rotates to block the air passage of the vacuum detector, so that the external detector can detect whether the nozzle clamps the product or not.

2. The cylinder body is provided with a first reset spring, and a third reset spring is arranged on the A face of the stopper, and a third reset spring is arranged between the upper gripper and the lower gripper, so that the piston can quickly reset when the nozzle clamp lowers the clamping object.

3. The air outlet of the vacuum test piece is provided with a cushion, which can enhance the air tightness between the barrier piece and the vacuum test piece, and can avoid the abrasion when the hard material resists.



GRT20F  
无传感器(Without Sensor)

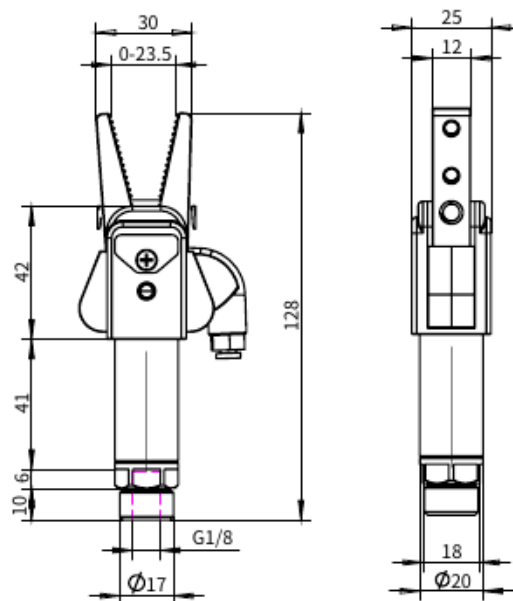

货号(PN)	型号(Model)	传感器(Sensor)	抓取力(F)	重量(Weight)
8.Y01008	GRT20F	-	100N	111g

## 水口夹具 Sprue Gripper

带齿标准爪, 双作用功能。  
完全兼容CRG的模块化EOAT/夹取系统。  
轴直径25毫米, 选配30毫米。

要求:  
工作气压 6 bar。  
需要过滤干燥空气

Standard jaws with teeth, Double action function.  
Fully compatible with CRG's modular EOAT/gripper system.  
Shaft diameter 25mm, optional 30mm.

Requirements:  
Working air pressure 6 bar.  
Requires filtered dry air.



GRP32A  
无传感器  
(Without Sensor)



GRP32B  
无传感器  
(Without Sensor)



GRP32A-30  
无传感器  
(Without Sensor)



GRP32B-30  
无传感器  
(Without Sensor)



GRP32A-CN(CP)  
带传感器  
(With Sensor)



GRP32B-CN(CP)  
带传感器  
(With Sensor)



GRP32A-30CN(CP)  
带传感器  
(With Sensor)



GRP32B-30CN(CP)  
带传感器  
(With Sensor)

货号(PN)	型号(Model)	传感器(Sensor)	闭合力(F)	重量(Weight)
8.Y00278	GRP32A	-	200N	604g
8.Y00462	GRP32A-CP	PNP	200N	658g
8.Y00463	GRP32A-CN	NPN	200N	658g
8.Y00388	GRP32B	-	200N	608g
8.Y00466	GRP32B-CP	PNP	200N	662.4g
8.Y00467	GRP32B-CN	NPN	200N	662.4g
8.Y00315	GRP32A-30	-	200N	1276g
8.Y00464	GRP32A-30CP	PNP	200N	1330g
8.Y00465	GRP32A-30CN	NPN	200N	1330g
8.Y00387	GRP32B-30	-	200N	1282g
8.Y00399	GRP32B-30CP	PNP	200N	1336g
8.Y00411	GRP32B-30CN	NPN	200N	1336g

型材、钢管  
Profile, SUS Tube

支架模组  
Stents Module

快换  
Quick Changer

夹具组件  
Grip Module

气动剪刀  
Air Nipper

真空组件  
Vacuum Module

附件  
Accessory Components

# 水口夹具

## Sprue Gripper

Profile, SUS Tube  
型材、钢管

Stents Module  
支架模组

Quick Changer  
快换

Grip Module  
夹具组件

Air Nipper  
气动剪刀

Vacuum Module  
真空组件

Accessory Components  
附件

带齿标准爪，双作用功能。  
完全兼容CRG的模块化EOAT/夹取系统。

轴直径25毫米，选配30毫米。

要求:

工作气压 6 bar。

需要过滤干燥空气

Standard jaws with teeth, Double action function.

Fully compatible with CRG's modular EOAT/gripper system.

Shaft diameter 25mm, optional 30mm.

Requirements:

Working air pressure 6 bar.

Requires filtered dry air.



GRP32C  
无传感器  
(Without Sensor)



GRP32A-3020  
无传感器  
(Without Sensor)



GRP32B-3020  
无传感器  
(Without Sensor)



GRP32C-3020  
无传感器  
(Without Sensor)



GRP32C-30  
无传感器  
(Without Sensor)



GRP32A-3020CN(CP)  
带传感器  
(With Sensor)



GRP32B-3020CN(CP)  
带传感器  
(With Sensor)

货号(PN)	型号(Model)	传感器(Sensor)	闭合力(F)	重量(Weight)
8.Y00468	GRP32A-3020	-	200N	1600g
8.Y00469	GRP32A-3020CP	PNP	200N	1654g
8.Y00477	GRP32A-3020CN	NPN	200N	1654g
8.Y00478	GRP32B-3020	-	200N	1604g
8.Y00416	GRP32B-3020CP	PNP	200N	1658g
8.Y00417	GRP32B-3020CN	NPN	200N	1658g
8.Y00412	GRP32C	-	200N	614g
8.Y00415	GRP32C-30	-	200N	1286g
8.Y00418	GRP32C-3020	-	200N	1610g

# GRP32A系列

## GRP32A Series

带齿标准爪，双作用功能。  
完全兼容CRG的模块化EOAT/夹取系统。  
轴直径25毫米，选配30毫米。

要求：  
工作气压 6 bar。  
需要过滤干燥空气

Standard jaws with teeth, Double action function.  
Fully compatible with CRG's modular EOAT/gripper system.  
Shaft diameter 25mm, optional 30mm.  
Requirements:  
Working air pressure 6 bar.  
Requires filtered dry air.



斜齿  
Helical tooth

直径 $\varnothing 25$ 、选配 $\varnothing 30$   
可更换长度50、100、150  
Diameter  $\varnothing 25$ , select  $\varnothing 30$   
Length can changes to 50, 100, 150

GRP32A  
无传感器(Without Sensor)



MAP-8S2P1/F (PNP)  
MAP-8S2N1/F (NPN)

直径 $\varnothing 25$ 、选配 $\varnothing 30$   
可更换长度50、100、150  
Diameter  $\varnothing 25$ , select  $\varnothing 30$   
Length can changes to 50, 100, 150

GRP32A-CN(CP)  
带传感器(With Sensor)

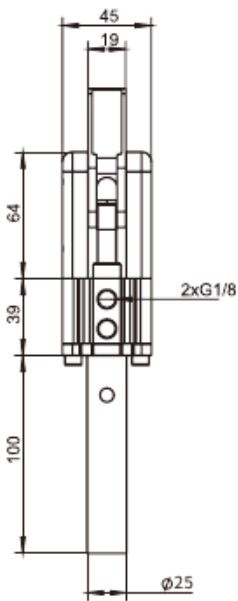

无传感器(Without Sensor)

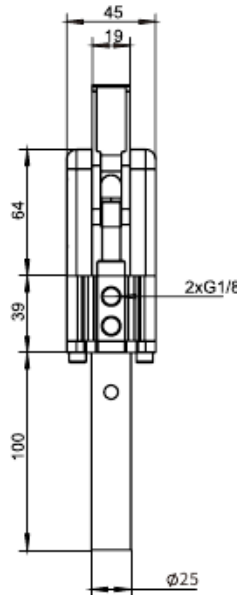
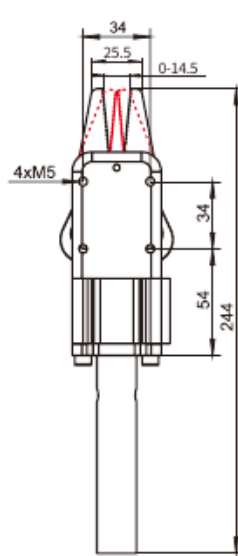

带传感器(With Sensor)

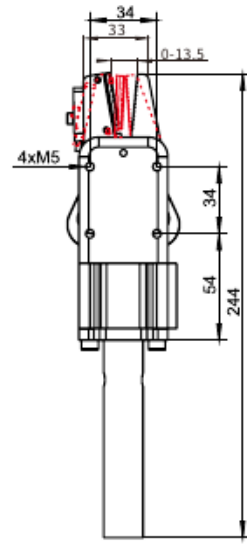

货号(PN)	型号(Model)	传感器(Sensor)	闭合力(F)	重量(Weight)
8.Y00278	GRP32A	-	200N	604g
8.Y00462	GRP32A-CP	PNP	200N	658g
8.Y00463	GRP32A-CN	NPN	200N	658g

型材、钢管  
Profile, SUS Tube

支架模组  
Stents Module

快换  
Quick Changer

夹具组件  
Grip Module

气动剪刀  
Air Nipper

真空组件  
Vacuum Module

附件  
Accessory Components

# GRP32B系列

## GRP32B Series

带齿标准爪，双作用功能。  
完全兼容CRG的模块化EOAT/夹取系统。  
轴直径25毫米，选配30毫米。  
要求：  
工作气压6 bar。  
需要过滤干燥空气

Standard jaws with teeth, Double action function.  
Fully compatible with CRG's modular EOAT/gripper system.  
Shaft diameter 25mm, optional 30mm.  
Requirements:  
Working air pressure 6 bar.  
Requires filtered dry air.



直径 $\varnothing$ 25、选配 $\varnothing$ 30  
可更换长度50、100、150  
Diameter  $\varnothing$ 25, select  $\varnothing$ 30  
Length can changes to 50, 100, 150

GRP32B  
无传感器(Without Sensor)



钻石齿  
Diamond tooth



MAP-8S2P1/F (PNP)  
MAP-8S2N1/F (NPN)

直径 $\varnothing$ 25、选配 $\varnothing$ 30  
可更换长度50、100、150  
Diameter  $\varnothing$ 25, select  $\varnothing$ 30  
Length can changes to 50, 100, 150

GRP32B-CN(CP)  
带传感器(With Sensor)

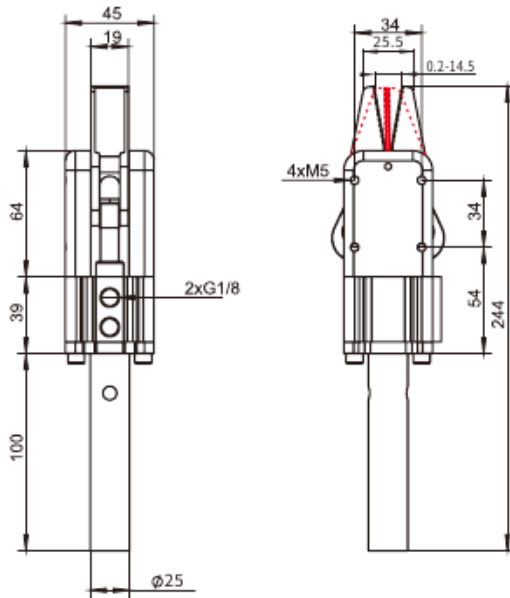

无传感器(Without Sensor)

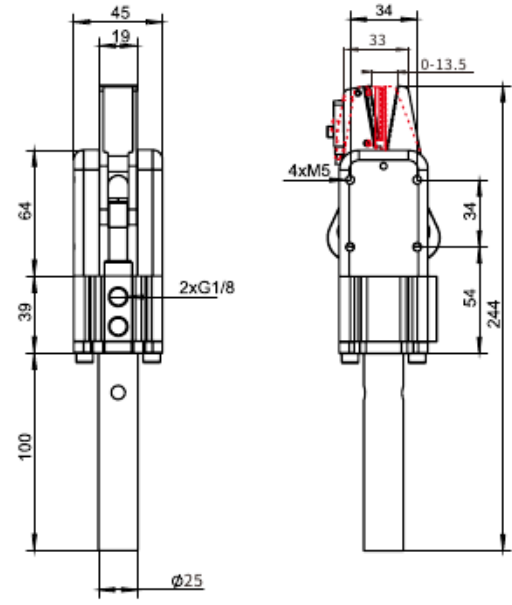

带传感器(With Sensor)

货号(PN)	型号(Model)	传感器(Sensor)	闭合力(F)	重量(Weight)
8.Y00388	GRP32B	-	200N	608g
8.Y00466	GRP32B-CP	PNP	200N	662.4g
8.Y00467	GRP32B-CN	NPN	200N	622.4g

Profile、SUS Tube  
型材、钢管

Stents Module  
支架模组

Quick Changer  
快换

Grip Module  
夹具组件

Air Nipper  
气动剪刀

Vacuum Module  
真空组件

Accessory Components  
附件

# GRP32A-30系列

## GRP32A-30 Series

带齿标准爪，双作用功能。  
完全兼容CRG的模块化EOAT/夹取系统。  
轴直径25毫米，选配30毫米。

要求：  
工作气压6 bar。  
需要过滤干燥空气

Standard jaws with teeth, Double action function.  
Fully compatible with CRG's modular EOAT/gripper system.  
Shaft diameter 25mm, optional 30mm.

Requirements:  
Working air pressure 6 bar.  
Requires filtered dry air.



直径 $\varnothing$ 25、选配 $\varnothing$ 30  
可更换长度50、100、150  
Diameter  $\varnothing$ 25, select  $\varnothing$ 30  
Length can changes to 50, 100, 150

GRP32A-30  
无传感器(Without Sensor)



斜齿  
Helical tooth



MAP-8S2P1/F (PNP)  
MAP-8S2N1/F (NPN)

直径 $\varnothing$ 25、选配 $\varnothing$ 30  
可更换长度50、100、150  
Diameter  $\varnothing$ 25, select  $\varnothing$ 30  
Length can changes to 50, 100, 150

GRP32A-30CN(CP)  
带传感器(With Sensor)

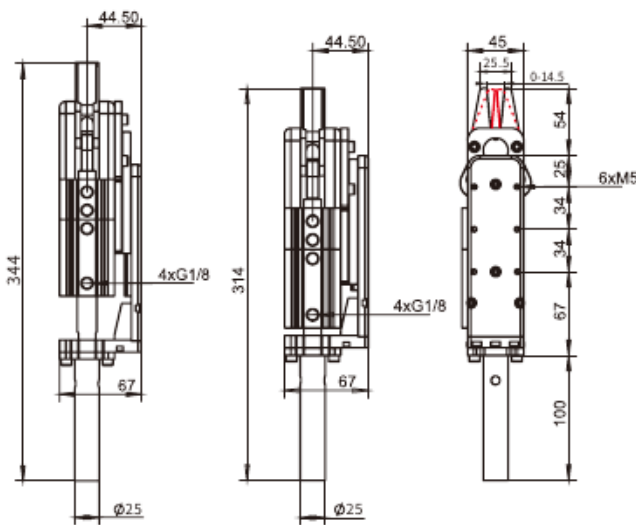

无传感器(Without Sensor)

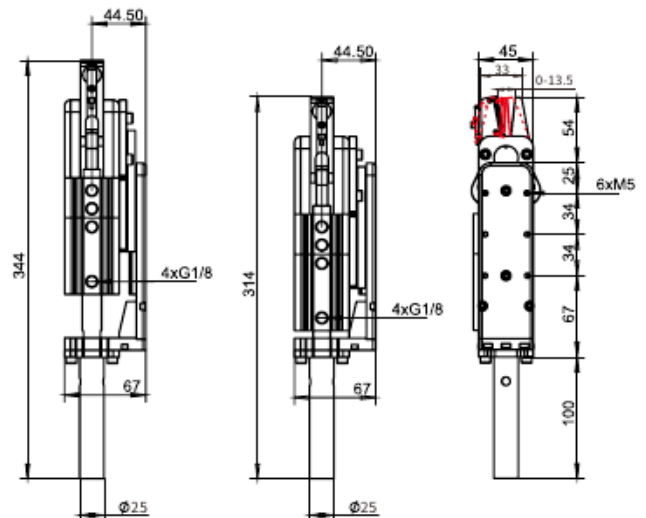

带传感器(With Sensor)

货号(PN)	型号(Model)	传感器(Sensor)	抓取力(F)	重量(Weight)
8.Y00315	GRP32A-30	-	200N	1276g
8.Y00464	GRP32A-30CP	PNP	200N	1330g
8.Y00465	GRP32A-30CN	NPN	200N	1330g

型材、钢管  
Profile, SUS Tube

支架模组  
Stents Module

快换  
Quick Changer

夹具组件  
Grip Module

气动剪刀  
Air Nipper

真空组件  
Vacuum Module

附件  
Accessory Components

# GRP32B-30系列

## GRP32B-30 Series

带齿标准爪, 双作用功能。  
完全兼容CRG的模块化EOAT/夹取系统。

轴直径25毫米, 选配30毫米。

要求:

工作气压 6 bar。

需要过滤干燥空气

Standard jaws with teeth, Double action function.

Fully compatible with CRG's modular EOAT/gripper system.

Shaft diameter 25mm, optional 30mm.

Requirements:

Working air pressure 6 bar.

Requires filtered dry air.



直径 $\varnothing$ 25、选配 $\varnothing$ 30  
可更换长度50、100、150  
Diameter  $\varnothing$ 25, select  $\varnothing$ 30  
Length can changes to 50, 100, 150

GRP32B-30  
无传感器(Without Sensor)



钻石齿  
Diamond tooth



MAP-8S2P1/F (PNP)  
MAP-8S2N1/F (NPN)

直径 $\varnothing$ 25、选配 $\varnothing$ 30  
可更换长度50、100、150  
Diameter  $\varnothing$ 25, select  $\varnothing$ 30  
Length can changes to 50, 100, 150

GRP32B-30CN(CP)  
带传感器(With Sensor)

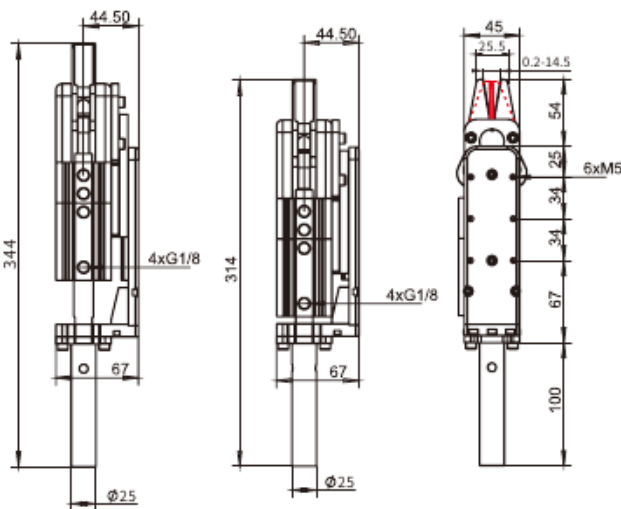

无传感器(Without Sensor)

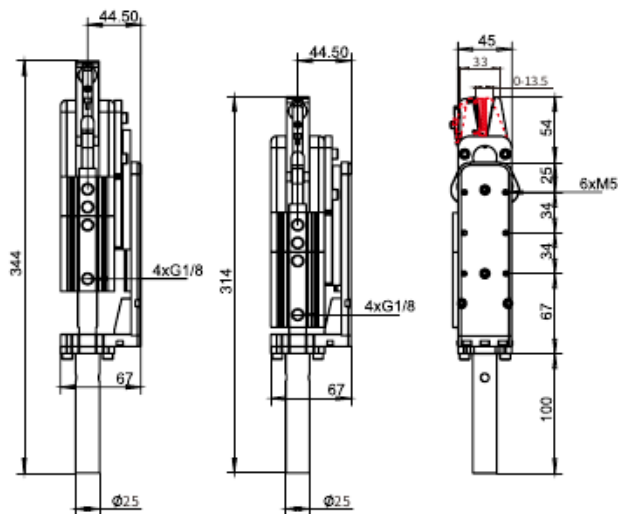

带传感器(With Sensor)

货号(PN)	型号(Model)	传感器(Sensor)	抓取力(F)	重量(Weight)
8.Y00387	GRP32B-30	-	200N	1282g
8.Y00399	GRP32B-30CP	PNP	200N	1336g
8.Y00411	GRP32B-30CN	NPN	200N	1336g

Profile、SUS Tube  
型材、钢管

Stents Module  
支架模组

Quick Changer  
快换

Grip Module  
夹具组件

Air Nipper  
气动剪刀

Vacuum Module  
真空组件

Accessory Components  
附件

# GRP32A-3020系列

## GRP32A-3020 Series

带齿标准爪, 双作用功能。  
完全兼容CRG的模块化EOAT/夹取系统。  
轴直径25毫米, 选配30毫米。  
要求:  
工作气压 6 bar。  
需要过滤干燥空气

Standard jaws with teeth, Double action function.  
Fully compatible with CRG's modular EOAT/gripper system.  
Shaft diameter 25mm, optional 30mm.  
Requirements:  
Working air pressure 6 bar.  
Requires filtered dry air.



斜齿  
Helical tooth

直径 $\varnothing$ 25、选配 $\varnothing$ 30  
可更换长度50、100、150  
Diameter  $\varnothing$ 25, select  $\varnothing$ 30  
Length can changes to 50, 100, 150

GRP32A-3020  
无传感器(Without Sensor)



MAP-8S2P1/F (PNP)  
MAP-8S2N1/F (NPN)

直径 $\varnothing$ 25、选配 $\varnothing$ 30  
可更换长度50、100、150  
Diameter  $\varnothing$ 25, select  $\varnothing$ 30  
Length can changes to 50, 100, 150

GRP32A-3020CN(CP)  
带传感器(With Sensor)

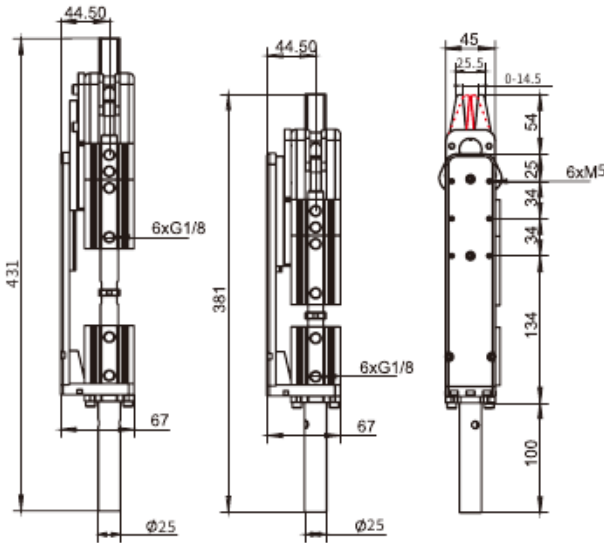

无传感器(Without Sensor)

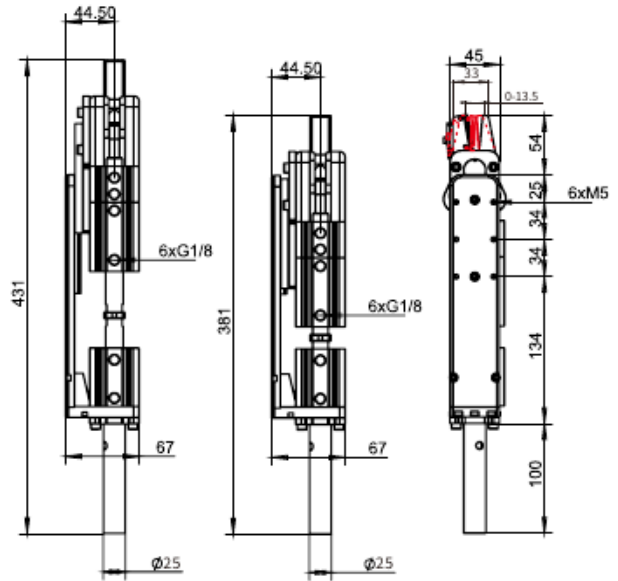

带传感器(With Sensor)

货号(PN)	型号(Model)	传感器(Sensor)	闭合力(F)	重量(Weight)
8.Y00468	GRP32A-3020	-	200N	1600g
8.Y00469	GRP32A-3020CP	PNP	200N	1654g
8.Y00477	GRP32A-3020CN	NPN	200N	1654g

Profile- SUS Tube  
型材、钢管

Stents Module  
支架模组

Quick Changer  
快换

Gripper Module  
夹具组件

Air Nipper  
气动剪刀

Vacuum Module  
真空组件

Accessory Components  
附件

# GRP32B-3020系列

## GRP32B-3020 Series

带齿标准爪，双作用功能。  
完全兼容CRG的模块化EOAT/夹取系统。  
轴直径25毫米，选配30毫米。

要求：  
工作气压6 bar。  
需要过滤干燥空气

Standard jaws with teeth, Double action function.  
Fully compatible with CRG's modular EOAT/gripper system.  
Shaft diameter 25mm, optional 30mm.

Requirements:  
Working air pressure 6 bar.  
Requires filtered dry air.



直径Ø25、选配Ø30  
可更换长度50、100、150  
Diameter ø25, select ø30  
Length can changes to 50, 100, 150

GRP32B-3020  
无传感器(Without Sensor)



钻石齿  
Diamond tooth



MAP-8S2P1/F (PNP)  
MAP-8S2N1/F (NPN)

直径Ø25、选配Ø30  
可更换长度50、100、150  
Diameter ø25, select ø30  
Length can changes to 50, 100, 150

GRP32B-3020CN(CP)  
带传感器(With Sensor)

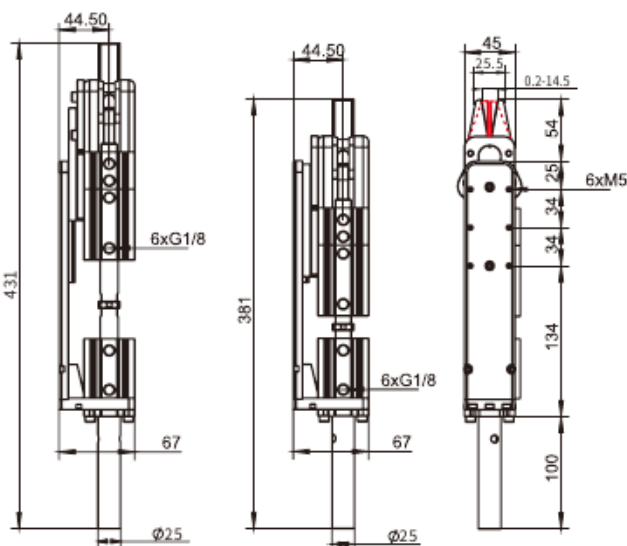

无传感器(Without Sensor)

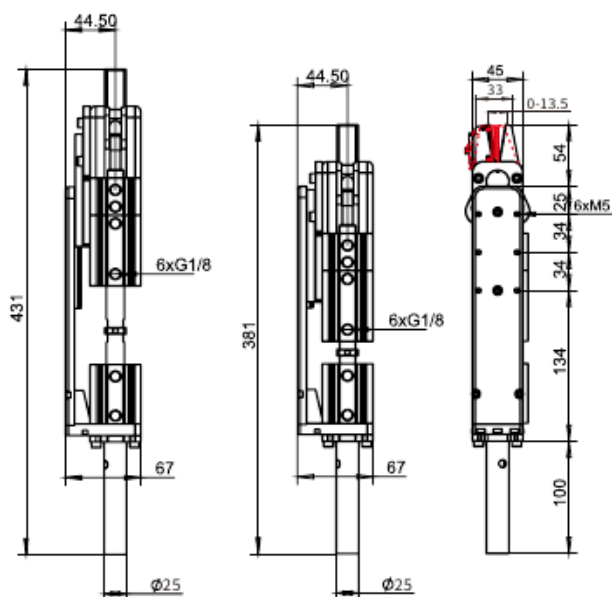

带传感器(With Sensor)

货号(PN)	型号(Model)	传感器(Sensor)	闭合力(F)	重量(Weight)
8.Y00478	GRP32B-3020	-	200N	1604g
8.Y00416	GRP32B-3020CP	PNP	200N	1658g
8.Y00417	GRP32B-3020CN	NPN	200N	1658g

Profile、SUS Tube  
型材、钢管

Stents Module  
支架模组

Quick Changer  
快换

Grip Module  
夹具组件

Air Nipper  
气动剪刀

Vacuum Module  
真空组件

Accessory Components  
附件

# GRP32C系列

## GRP32C Series

带齿标准爪, 双作用功能。  
完全兼容CRG的模块化EOAT/夹取系统。  
轴直径25毫米, 选配30毫米。

要求:  
工作气压 6 bar。  
需要过滤干燥空气

Standard jaws with teeth, Double action function.  
Fully compatible with CRG's modular EOAT/gripper system.  
Shaft diameter 25mm, optional 30mm.

Requirements:  
Working air pressure 6 bar.  
Requires filtered dry air.



直径 $\varnothing 25$ 、选配 $\varnothing 30$   
可更换长度50、100、150  
Diameter  $\varnothing 25$ , select  $\varnothing 30$   
Length can changes to 50, 100, 150

GRP32C  
无传感器(Without Sensor)



直径 $\varnothing 25$ 、选配 $\varnothing 30$   
可更换长度50、100、150  
Diameter  $\varnothing 25$ , select  $\varnothing 30$   
Length can changes to 50, 100, 150

GRP32C-30  
无传感器(Without Sensor)

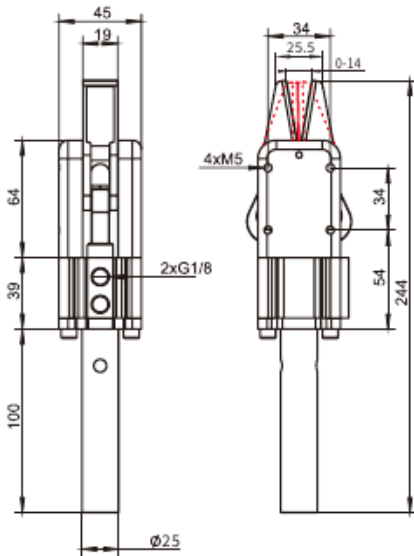

无传感器(Without Sensor)

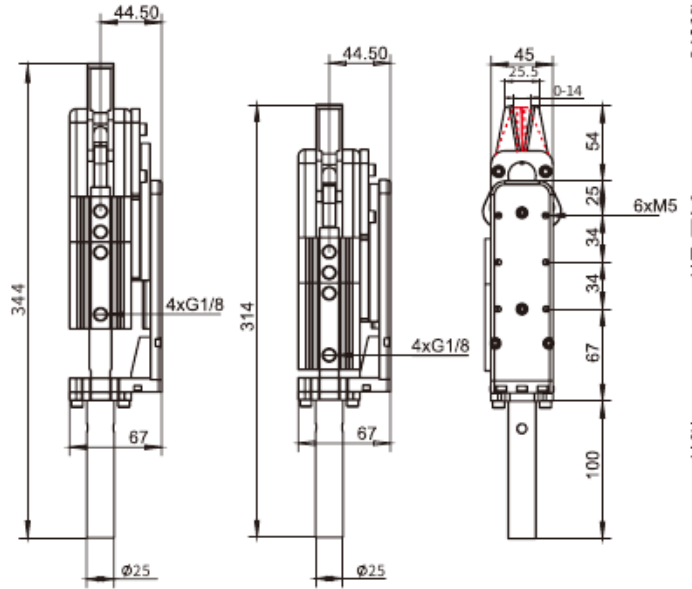

无传感器(Without Sensor)

货号(PN)	型号(Model)	传感器(Sensor)	闭合力(F)	重量(Weight)
8.Y00412	GRP32C	-	200N	614g
8.Y00415	GRP32C-30	-	200N	1286g

Profile- SUS Tube  
型材、钢管

Stents Module  
支架模组

Quick Changer  
快换

Grip Module  
夹具组件

Air Nipper  
气动剪刀

Vacuum Module  
真空组件

Accessory Components  
附件

# GRP32C-3020系列

## GRP32C-3020 Series

带齿标准爪, 双作用功能。  
完全兼容CRG的模块化EOAT/夹取系统。  
轴直径25毫米, 选配30毫米。

要求:  
工作气压 6 bar。  
需要过滤干燥空气

Standard jaws with teeth, Double action function.  
Fully compatible with CRG's modular EOAT/gripper system.  
Shaft diameter 25mm, optional 30mm.

Requirements:  
Working air pressure 6 bar.  
Requires filtered dry air.



直径Ø25、选配Ø30  
可更换长度50、100、150  
Diameter ø25, select ø30  
Length can changes to 50, 100, 150

GRP32C-3020  
无传感器(Without Sensor)

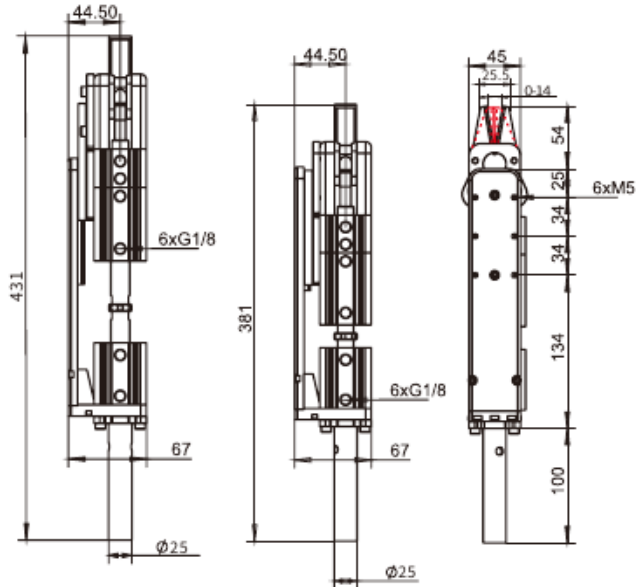

无传感器(Without Sensor)

货号(PN)	型号(Model)	传感器(Sensor)	闭合力(F)	重量(Weight)
8.Y00418	GRP32C-3020	-	200N	1610g

Profile、SUS Tube  
型材、钢管

Stents Module  
支架模组

Quick Changer  
快换

Grip Module  
夹具组件

Air Nipper  
气动剪刀

Vacuum Module  
真空组件

Accessory Components  
附件

# 圆形大力夹

## Round Power Clamp

NEW

头部夹钳可适配替换炮筒剪刀  
夹持力是传统大力夹的1.75倍,约350N

The head clamp can be used as a replacement for barrel shears.  
Its gripping force is 1.75 times that of a traditional heavy-duty clamp,  
approximately 350 N.



NR20A  
无传感器(Without Sensor)



NR20A-30  
无传感器(Without Sensor)

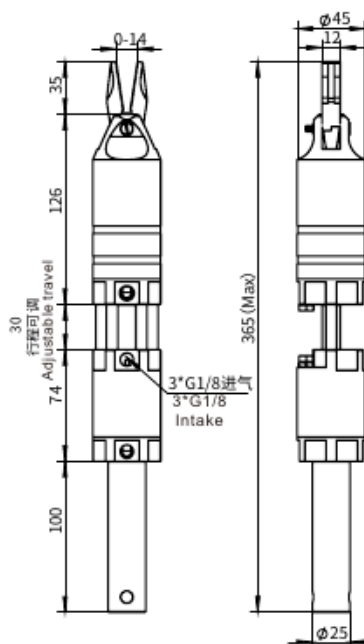
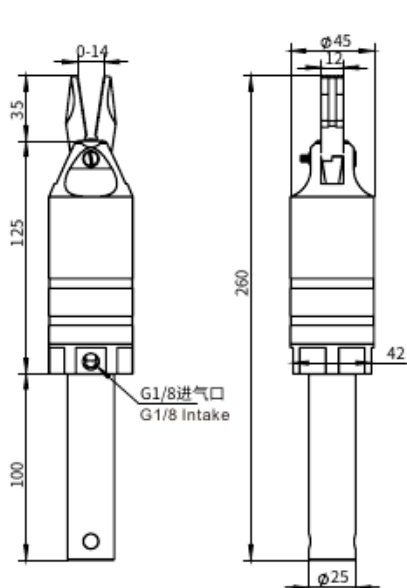

货号(PN)	型号(Model)	传感器(Sensor)	闭合力(F)	重量(Weight)
8.Y01322	NR20A	-	350N	512g
8.Y01323	NR20A-30	-	350N	803g

Profile- SUS Tube  
型材、钢管

Stents Module  
支架模组

Quick Changer  
快换

Grip Module  
夹具组件

Air Nipper  
气动剪刀

Vacuum Module  
真空组件

Accessory Components  
附件

# 柔触手爪简介

## Rochu Gripper Introduction

柔触手爪运用了仿生学原理，模仿章鱼触手包裹被抓对象的动作，对物体进行包覆式抓取。

传统夹具常常会因为物体形状、材质、抓取要求等多种局限，无法提供成功的抓取方案。而柔触手爪，由柔性材料制成，不会损伤被抓物件的同时，由于其厘米级的自适应能力，而具备极高的通用性，一爪万能，适合不同形状的物体，用户无需频繁更换夹具。

柔触手爪填补了机器人末端夹爪的此类空缺，极大地拓宽了工业机器人的应用场景。

Flexible soft grippers uses the principle of bionics to imitate the action of Octopus tentacle wrapping the captured object, so as to grasp the object in a wrapping way.

Traditional fixture often can't provide a successful grasping scheme because of the limitations of object shape, material, grasping requirements and so on. Flexible soft grippers, made of flexible materials, will not damage the object to be caught. At the same time, due to its centimeter level adaptive ability, it has high versatility. One claw is omnipotent, suitable for different shapes of objects, and users do not need to replace the fixture frequently. Flexible soft grippers fills the gap of the End-Of-Arm-Tooling, and greatly expands the application of industrial robot.

### 动作原理

#### Working principle

柔触手爪采用气动驱动技术，通过正负压切换，实现柔性手指/柔喙的张开和闭合动作，从而实现柔性抓取或外撑的动作。

同时通过调节空气压强来控制手爪的夹紧力度或开合角度，实现对不同物件的柔性抓取，同时避免夹伤物件。

Flexible soft grippers adopt pneumatic drive technology, through positive and negative pressure transform to achieve fingers opening and closing movement. Then realize flexible gripping or outrigger action. The gripper grab strength is adjusted by air pressure. Then achieve flexible gripping of different objects while avoiding damage objects.



产品使用气压必须严格控制在安全工作压力范围内，过载使用可能会对产品造成不可逆转的损害；使用时建议使用原厂驱动器，以保证产品使用寿命与稳定性，产品使用气压请参照产品页或包装标识。

The working pressure must be kept within a safe range, overload may cause irreversible damage of the finger. It is recommended to use our "Rochu control unit" to ensure the life time and stability of the soft finger and beak. Please refer to the product page or packaging mark for the air pressure of the product.

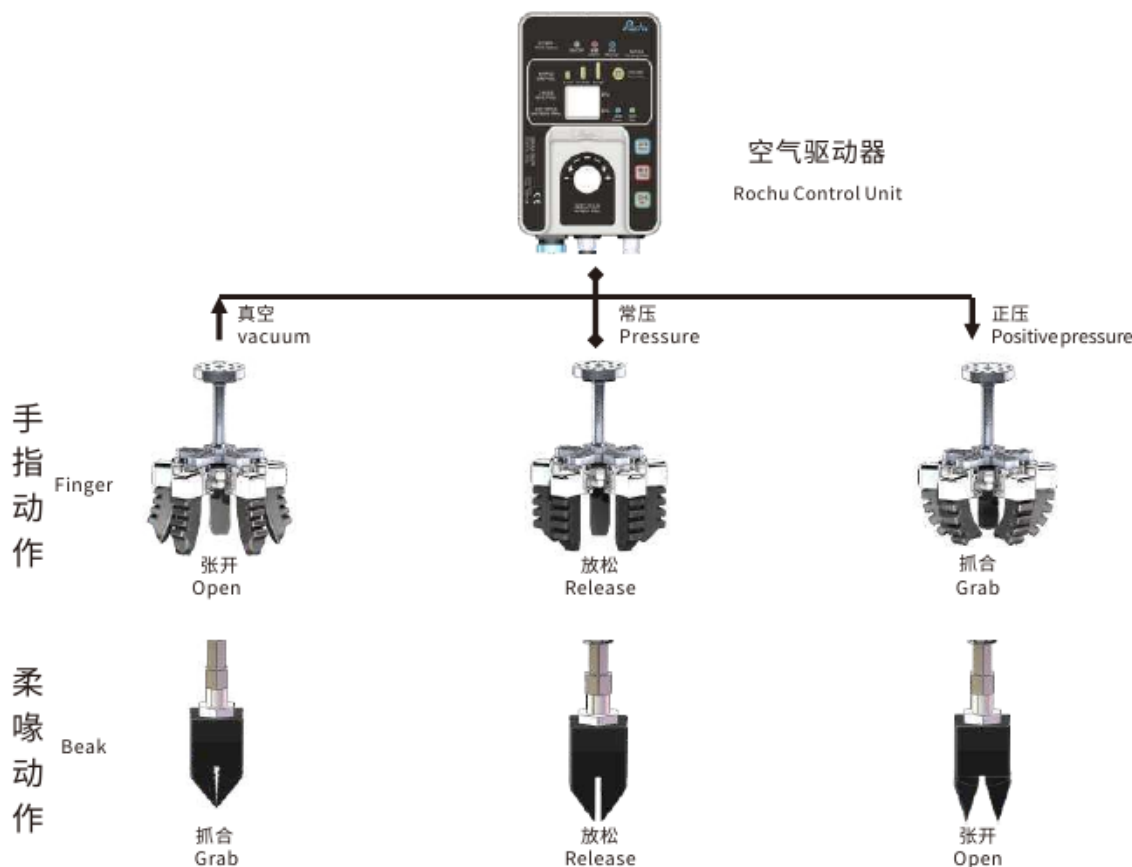

## 使用领域

### Application

柔性手指的抓取动作灵感来自于章鱼的触须，能柔软的包裹被抓取物体，在实现柔性抓取的同时不会损坏物体或在物体表面留下划痕。并广泛应用于汽车零部件、3C电子、食品、医疗、服装、日化等多种行业。柔性手爪可用于装配、分拣、搬运等多种工业场合，也可以用于自动售卖机等新零售行业。安全性高、通用性好、安装简单方便，弥补了机械夹爪和真空吸盘在某些场合所无法适用的空缺。

The grasping action of flexible fingers is inspired by the tentacles of octopus, which can wrap the captured object in a soft way, without damaging the object or leaving scratches on the surface of the object. And widely used in auto parts, 3C electronics, food, medical, clothing, daily chemical and other industries. The flexible gripper can be used in assembly, sorting, handling and other industrial occasions, and can also be used in new retail industries such as vending machines. It has the advantages of high safety, good versatility, simple and convenient installation, and makes up for the vacancy that the mechanical clamping claw and vacuum cup can not be applied in some occasions.



### 食品生鲜

#### Food

食品级材料安全无毒，通过了FDA食品级检测标准，可直接接触食物本身，尤其适用于果蔬、不规则真空包装食品、奶制品、面团糕点等分拣包装。

Food safe materials. FDA and EC-1935 certification. Used for pick and place of fruits, dough, candies, pastry and vegetables.



### 服装面料

#### Clothing fabric

适用于针织和梭织面料的分层抓取或多层同时抓取，分层抓取时只抓取堆叠材料的最上一层，也可用于堆叠裁片的整叠搬运。

It's suitable for layer grabbing or multi-layer grabbing of knitted and woven fabrics at the same time. When layer grabbing, only the top layer of stacked materials can be grabbed, and it can also be used for stacking and handling of stacked pieces.



### 智能抓取

#### Smart picking

基于人工智能技术的智能抓取。可以用于无序堆叠，复杂场景下的来料分选与物流包装。

Smart picking based on artificial intelligence technology. It can be used for sorting and logistics packaging under disorderly stacking and complex scenes.



### 3C电子

#### 3C-electronics

适用于精密电子仪器的高精度插拔，以及对手机等相关配件、电路板、硅片、薄玻璃等工件的组装、分拣、测试、包装等工序。

It is used for high-precision plug and pull of small electronic parts. Assembling, sorting, testing and packaging of ceramic and plastic parts in mobile phone, PCBs, silicon wafers, optic glasses.



### 汽车零部件

#### Auto mobile

用于汽车车灯、金属异形件、外观件的分拣、搬运、上下料，尤其适用于小批量、多批次的柔性生产需求。

Used for sorting, transporting, loading and unloading of automobile lamps, metal special-shaped parts and appearance parts, especially suitable for small batch and multi batch flexible production.



### 医疗用品

#### Medical Supplies

用于输液管、试管，安瓿瓶等医疗耗材的抓取，也可抓取瓶装、袋装试剂，包括用于医疗器械的生产、消毒等工序。

It is used for grasping medical consumables such as infusion tube, test tube and ampoule bottle, as well as bottled and bagged reagents, including the production and disinfection of medical devices.

型材、钢管  
Profile, SUS Tube

支架模组  
Stents Module

快换  
Quick Changer

夹具组件  
Grip Module

气动剪刀  
Air Nipper

真空组件  
Vacuum Module

附件  
Accessory Components

# V5系列手指模块

## Series-GFM-V5 Finger Module

Profile, SUS Tube  
型材、钢管

Stents Module  
支架模组

Quick Changer  
快换

Grip Module  
夹具组件

Air Nipper  
气动剪刀

Vacuum Module  
真空组件

Accessory Components  
附件

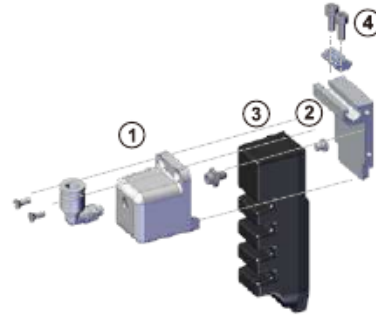

- ① 罩盖S-AV5
- ② 堵头PN-166
- ③ 柔触手指F-A5T/LS1
- ④ 滑槽螺母TN-03

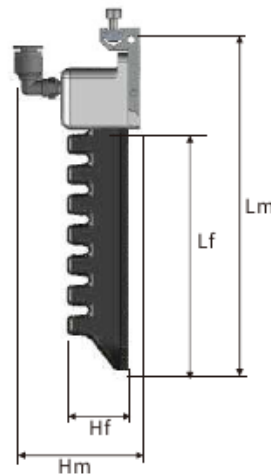

系列 Series	货号 PN	型号 Model	指尖行程 HR [mm]	负压行程* Hmax [mm]		正压行程** Hmin [mm]	模块高度 Hm [mm]	手指高度 Hf [mm]	模块长度 Lm [mm]	手指长度 Lf [mm]	模块宽度 Wm [mm]	手指宽度 Wf [mm]	自重 [g]	安全工作气压 (Kpa)		
				常规型手指	增强型手指									常规型手指	增强型手指	
A款	4.Y00500	GFM-A3V5	16.5	8	7	8.5	58	28	88	41	31	24	76	120	300	
	4.Y00501	GFM-A4V5	27	10	12	17										83
	4.Y00502	GFM-A5V5	43.5	19	16	24.5										90
	4.Y10951	GFM-A6V5	72	33	22	39										97
	4.Y10952	GFM-A7V5	90	39	27	51										104
	4.Y10953	GFM-A8V5	109	45	32	64										111
B款	4.Y00503	GFM-B3V5	19	10	6	9	51	21	71	31	25	18	44	120	260	
	4.Y00504	GFM-B4V5	29	13	10	16										48
	4.Y00505	GFM-B5V5	40	16	14	24										52
	4.Y10954	GFM-B6V5	53	23	17	30										56
	4.Y10955	GFM-B7V5	75	30	21	45										60
	4.Y10956	GFM-B8V5	98	37	25	61										64
C款	4.Y00506	GFM-C3V5	10.5	5	1	5.5	44	14	53	21	18	12	28	120	220	
	4.Y00507	GFM-C4V5	20	9	3	11										28
	4.Y00508	GFM-C5V5	27	12	8	15										29
	4.Y10957	GFM-C6V5	42	20	10	22										30
	4.Y10958	GFM-C7V5	63	29	13	34										31
	4.Y10959	GFM-C8V5	80	38	16	42										32

# 柔性手指

## Flexible Finger

A款  
Series-A

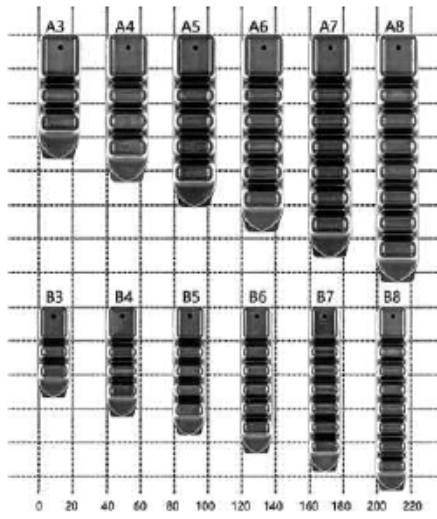

B款  
Series-B

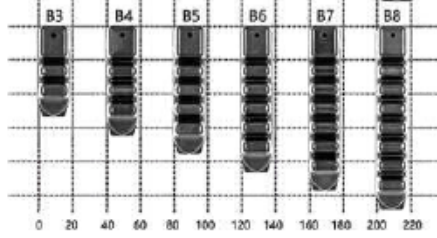

C款  
Series-C

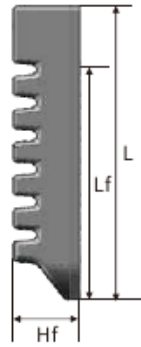
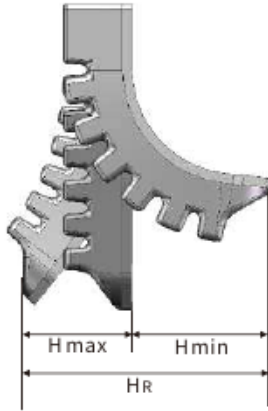
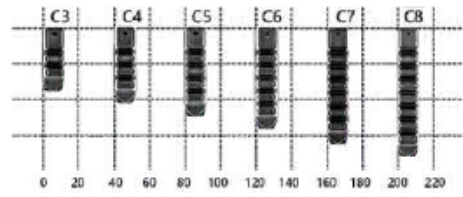

系列 Series	货号 PN	型号 Model	指尖行程 HR (mm)	负压行程* Hmax (mm)		正压行程** Hmin (mm)	高度 Hf (mm)	长度 Lf (mm)	总长度 L (mm)	指宽 Wf (mm)	自重 [g]	安全工作气压 (Kpa)		
				常规型手指	增强型手指							常规型手指	增强型手指	
A款	1.Y08421	A3	16.5	8	7	8.5	28	41	69	24	33	120	300	
	1.Y08422	A4	27	10	12	17		55	83					40
	1.Y08423	A5	43.5	19	16	24.5		69	97					47
	1.Y12918	A6	72	33	22	39		83	111					55
	1.Y12919	A7	90	39	27	51		97	125					62
	1.Y12920	A8	109	45	32	64		111	139					69
B款	1.Y08424	B3	19	10	6	9	21	31	52	18	11	120	260	
	1.Y08425	B4	29	13	10	16		42	62					16
	1.Y08426	B5	40	16	14	24		52	73					20
	1.Y12921	B6	53	23	17	30		63	83					24
	1.Y12922	B7	75	30	21	45		73	94					28
	1.Y12923	B8	98	37	25	61		84	104					32
C款	1.Y08427	C3	10.5	5	1	5.5	14	21	34	12	4	120	220	
	1.Y08428	C4	20	9	3	11		28	41					5
	1.Y08429	C5	27	12	8	15		35	48					6
	1.Y12924	C6	42	20	10	22		42	55					7
	1.Y12925	C7	63	29	13	34		49	62					7
	1.Y12926	C8	80	38	16	42		56	69					8

Profile- SUS Tube  
型材、钢管

Stents Module  
支架模组

Quick Changer  
快换

Grip Module  
夹具组件

Air Nipper  
气动剪刀

Vacuum Module  
真空组件

Accessory Components  
附件

# 柔喙套件

## Roro Beak Suit

### GBS-4B-S01 4尖套件

GBS-4B-S01 4 pieces Beak Suit



安装组合  
VFNT1011-M5  
Assembling Suit  
VFNT1011-M5

柔喙  
B-4B  
Roro Beak  
B-4B



三尖外撑抓取珠宝  
3 Pieces Application: Gripping jewelry by external bracing



三尖外撑抓取密封圈  
3 Pieces Application: Gripping ring by external bracing



四尖包裹式抓取电子产品  
4 Pieces Application: Gripping products in Electronic industry

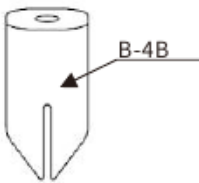
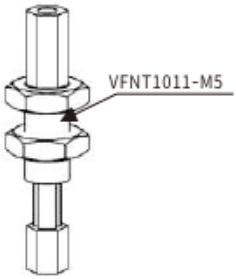

货号 (PN)	型号 (Model)	最大负载 (Maximum Load)	最高工作频率 (Maximum Working Frequency)	精度范围 (Precision Range)
4.Y00509	GBS-2B-S01	5 g	200 times/min	0.1 mm
4.Y00510	GBS-3B-S01	5 g	200 times/min	0.1 mm
4.Y00511	GBS-4B-S01	5 g	200 times/min	0.1 mm

Profile, SUS Tube  
型材、钢管

Stentis Module  
支架模组

Quick Changer  
快换

Grip Module  
夹具组件

Air Nipper  
气动剪刀

Vacuum Module  
真空组件

Accessory Components  
附件

# 柔喙

## Roro Beak

### 柔喙 B-2B

Roro Beak B-2B

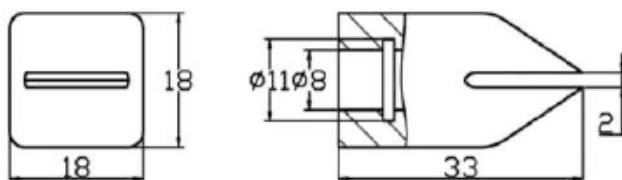

两尖柔喙, 夹取范围 1-5mm, 适用于纤维状、条状小物件  
2 pieces Roro Beak Gripping Range: 1-5mm, Application: fibrous, striped small objects

货号(PN)	1.Y08430
型号(Model)	B-2B

### 柔喙 B-3B

Roro Beak B-3B

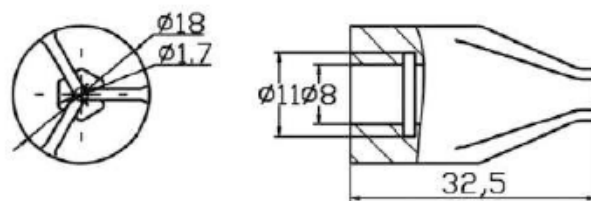

三尖柔喙, 夹取范围 7-12mm, 适用于外撑型抓取圆环状小物件  
3 pieces Roro Beak Gripping Range: 7-12mm, Application: gripping small rings by external bracing

货号(PN)	1.Y08431
型号(Model)	B-3B

### 柔喙 B-4B

Roro Beak B-4B

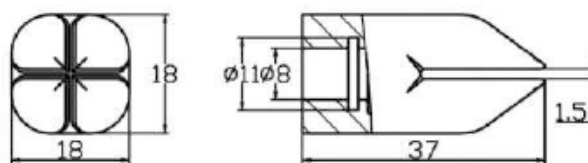

四尖柔喙, 夹取范围 1-5mm, 适用于球形、不规则小物件, 通用性最佳  
4 pieces Roro Beak Gripping Range: 1-5mm, Application: spherical, irregular small objects, the best universality

货号(PN)	1.Y08432
型号(Model)	B-4B

Profile- SUS Tube  
型材、钢管

Stents Module  
支架模组

Quick Changer  
快换

Grip Module  
夹具组件

Air Nipper  
气动剪刀

Vacuum Module  
真空组件

Accessory Components  
附件

# 滑移安装板

## Slide Mounting Plate

### GSMP-多向系列

GSMP- Multidirection

#### 产品特点

按形状和槽长度分为不同款式

可用于手指模块[FM]与法兰连接模块[FCM]间的装配

手指模块[FM]的安装角度和位置可自由调节

#### Features

- Different styles according to shape and slot length
- Can be used for assembly between finger module [FM] and flange connection module [FCM]
- The installation angle and position of finger module [FM] can be adjusted freely

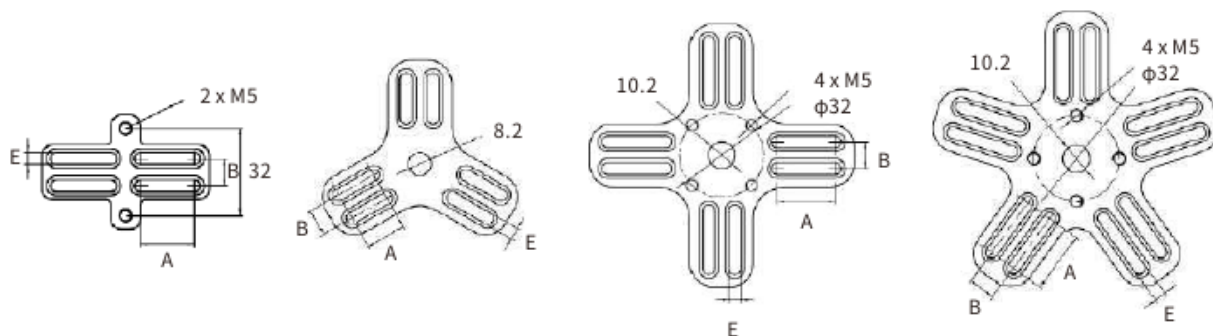
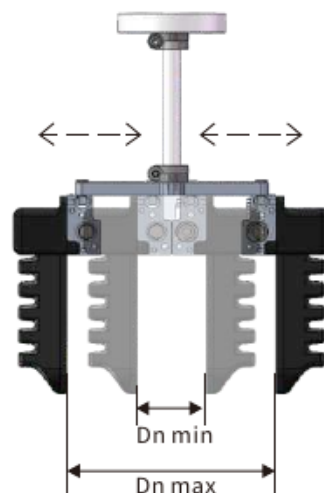

GSMP-2S



GSMP-3S



GSMP-4S



GSMP-5S



GSMP-2L



GSMP-3L



GSMP-4L



GSMP-5L

系列 Series	货号 PN	型号 Model	槽长 A [mm]	槽间距 B [mm]	槽宽 E [mm]	厚度 [mm]	常压指尖距 Dn [mm] Dnmin - Dnmax		自重 [g]
							V2, V4手指模块	V3, V5手指模块	
双向	7.Y01028	GSMP-2S	20	10	4.2	8	40-69	10-37	18.9
	7.Y01029	GSMP-2L	45	10	4.2	8	40-119	10-87	25.4
三向	7.Y01030	GSMP-3S	15	10	4.2	10	58-82	28-50	42.4
	7.Y01031	GSMP-3L	50	10	4.2	10	58-152	28-120	73.9
四向	7.Y01032	GSMP-4S	22	10	4.2	10	72-104	41-72	52.3
	7.Y01033	GSMP-4L	67	10	4.2	10	72-194	41-162	86.2
五向	7.Y01034	GSMP-5S	23	10	4.2	10	91-112	53-80	94.8
	7.Y01035	GSMP-5L	78	10	4.2	10	91-222	53-109	179.7

# 四指柔爪

## Four Soft Claws

### 型号表示方法

#### Model representation methods

**BMC-4G27**

直通模块  
Through train module



**[H] /SN**

[H]安全增强型  
Security enhancement

[HAS]安全增强无痕型  
Safety Enhancement Non-Scarring

**BML-4G27**

侧通模块  
Sidepass module



**[H] /SN**

[H]安全增强型  
Security enhancement

[HAS]安全增强无痕型  
Safety Enhancement Non-Scarring

真空vacuums



常压atmospheric

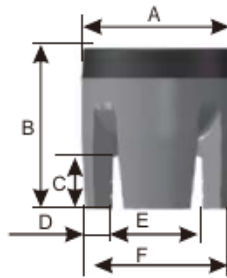

正压positive pressure

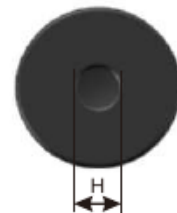

货号 PN	型号 Model	A	B	C	D	E	F	G	H	夹持范围 Clamping range	夹持力 Clamping force	夹持尺寸 Clamping Size	负载 Load	安全气压 Safe Air Pressure	重量 Weight
4.Y00543	BMC-4G27[H]/SN														17.5g
4.Y00544	BMC-4G27[HAS]/SN														32g
4.Y00545	BML-4G27[H]/SN	φ26.6	32	8.5	4	φ15.5	φ23.5	11.9	G1/8	8-22mm	0-2.6N	14mm	0-157g	<120kPa	
4.Y00546	BML-4G27[HAS]/SN														
4.Y00547	BMC-4G34[H]/SN														25.5g
4.Y00548	BMC-4G34[HAS]/SN														40g
4.Y00549	BML-4G34[H]/SN	φ34	36	11	5	φ20.5	φ30.5	14.8	G1/8	12-24mm	0-3.2N	18mm	0-191g	<120kPa	
4.Y00550	BML-4G34[HAS]/SN														
4.Y00551	BMC-4G39[H]/SN														29.2g
4.Y00552	BMC-4G39[HAS]/SN														43.7g
4.Y00553	BML-4G39[H]/SN	φ39	39.5	11	5	φ25.5	φ35.5	17.6	G1/8	15-27mm	0-6N	22mm	0-361g	<100kPa	
4.Y00554	BML-4G39[HAS]/SN														
4.Y00555	BMC-4G44[H]/SN														59.8g
4.Y00556	BMC-4G44[HAS]/SN														73.7g
4.Y00557	BML-4G44[H]/SN	φ44	43	11.5	5	φ32	φ42	20.2	G1/8	18-31.5mm	0-8.4N	30mm	0-505g	<150kPa	
4.Y00558	BML-4G44[HAS]/SN														
4.Y00559	BMC-4G51[H]/SN														50g
4.Y00560	BMC-4G51[HAS]/SN														54.5g
4.Y00561	BML-4G51[H]/SN	φ51	44	13	6	φ33	φ45	23.8	G1/8	20-35mm	0-12.3N	30mm	0-739g	<120kPa	
4.Y00562	BML-4G51[HAS]/SN														
4.Y00563	BMC-4G58[H]/SN														60.4g
4.Y00564	BMC-4G58[HAS]/SN														74.4g
4.Y00565	BML-4G58[H]/SN	φ58.5	47	15.5	7	φ42	φ56	27.6	G1/8	24.5-50mm	0-17.1N	40mm	0-1023g	<120kPa	
4.Y00566	BML-4G58[HAS]/SN														
4.Y00567	BMC-4G64[H]/SN														114.7g
4.Y00568	BMC-4G64[HAS]/SN														129.2g
4.Y00569	BML-4G64[H]/SN	φ64	50.5	16	7.5	φ45	φ60	30.9	G1/8	30-50mm	0-22.1N	45mm	0-1325g	<80kPa	
4.Y00570	BML-4G64[HAS]/SN														

使用寿命:150万次、接触工件温度:<220°C

Service life: 1.5 million times, contact with the workpiece temperature: <220 °C

Profile- SUS Tube

Stents Module

Quick Changer

Grip Module

Air Nipper

Vacuum Module

Accessory Components

# 二指柔爪 Soft Claw

Profile, SUS Tube  
型材、钢管

Stents Module  
支架模组

Quick Changer  
快换

Grip Module  
夹具组件

Air Gripper  
气动夹刀

Vacuum Module  
真空组件

Accessory Components  
附件

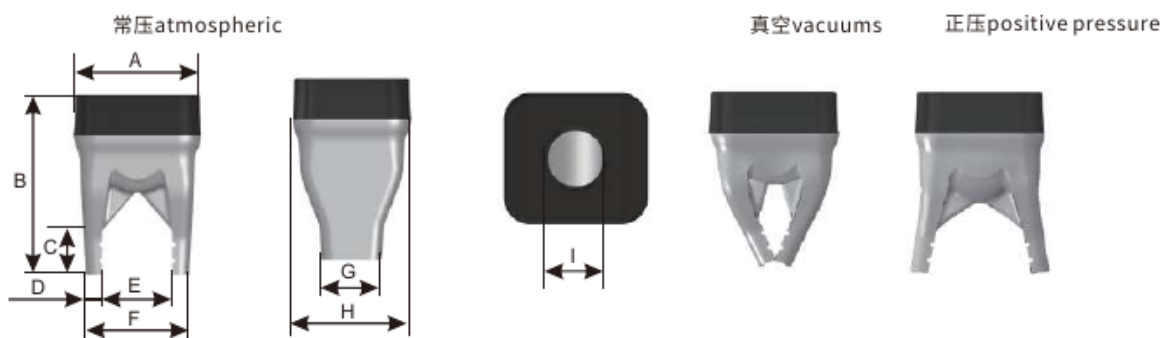

货号 PN	型号 Model	A	B	C	D	E	F	G	H	I	夹持范围 Clamping range	夹持力 Clamping force	负载 Load	夹持尺寸 Clamping Size	安全气压 Safe Air Pressure	重量 Weight
4.Y00571	BMC-2G1012[H]/SN															14.5g
4.Y00572	BMC-2G1012[HAS]/SN	22	30	7	3	11	17	10	20	G1/8	0-14mm	0-2.5N	0-102g	11mm	<100kPa	28.4g
4.Y00573	BML-2G1012[H]/SN															
4.Y00574	BML-2G1012[HAS]/SN															
4.Y00575	BMC-2G1622[H]/SN															23.6g
4.Y00576	BMC-2G1622[HAS]/SN	34	35.5	10	5	21	34	16	30	G1/8	0-25mm	0-9.4N	0-374g	21mm	<120kPa	38.1g
4.Y00577	BML-2G1622[H]/SN															
4.Y00578	BML-2G1622[HAS]/SN															
4.Y00579	BMC-2G2227[H]/SN															22.9g
4.Y00580	BMC-2G2227[HAS]/SN	37	37	11	4.4	25.5	33.5	20	25	G1/8	3-30mm	0-8.5N	0-338g	25.5mm	<140kPa	37.4g
4.Y00581	BML-2G2227[H]/SN															
4.Y00582	BML-2G2227[HAS]/SN															
4.Y00583	BMC-2G2232[H]/SN															26.1g
4.Y00584	BMC-2G2232[HAS]/SN	44	39	11	5.6	30.5	40.5	20	24.7	G1/8	20-35.5mm	0-9.7N	0-389g	30.5mm	<120kPa	40.6g
4.Y00585	BML-2G2232[H]/SN															
4.Y00586	BML-2G2232[HAS]/SN															
4.Y00587	BMC-2G2237[H]/SN															29.6g
4.Y00588	BMC-2G2237[HAS]/SN	49	43	13	5.7	35.5	46	20	25	G1/8	18-38mm	0-11.6N	0-463g	35.5mm	<120kPa	44.1g
4.Y00589	BML-2G2237[H]/SN															
4.Y00590	BML-2G2237[HAS]/SN															
4.Y00591	BMC-2G2242[H]/SN															31.8g
4.Y00592	BMC-2G2242[HAS]/SN	55	43.5	12	6	40.5	51.5	20	25	G1/8	26.5-40mm	0-9.6N	0-383g	40mm	<100kPa	45.8g
4.Y00593	BML-2G2242[H]/SN															
4.Y00594	BML-2G2242[HAS]/SN															
4.Y00595	BMC-2G2247[H]/SN															32g
4.Y00596	BMC-2G2247[HAS]/SN	57.3	43.5	11	4.9	46	54.8	20	25	G1/8	30-48mm	0-12N	0-480g	47mm	<100kPa	46g
4.Y00597	BML-2G2247[H]/SN															
4.Y00598	BML-2G2247[HAS]/SN															
4.Y00599	BMC-2G2252[H]/SN															34.2g
4.Y00600	BMC-2G2252[HAS]/SN	65.5	43.4	12	6	50.5	61.5	20	25	G1/8	34-52mm	0-14.2N	0-568g	52mm	<120kPa	48.1g
4.Y00601	BML-2G2252[H]/SN															
4.Y00602	BML-2G2252[HAS]/SN															
4.Y00603	BMC-2G2257[H]/SN															35.2g
4.Y00604	BMC-2G2257[HAS]/SN	68.3	44.4	13	5.4	57	67	20	25	G1/8	38-59mm	0-13.5N	0-540g	58mm	<100kPa	49.2g
4.Y00605	BML-2G2257[H]/SN															
4.Y00606	BML-2G2257[HAS]/SN															

使用寿命:150万次、接触工件温度: <220°C  
Service life: 1.5 million times, contact with the workpiece temperature: <220 ° C

## LCU-S 轻型驱动模块(标准型)

### LCU-S Light Duty Drive Module (Standard)

- 适配全系列柔爪和柔指,可配合精密调压阀精密调节夹持力。
- 体积小,重量轻,响应速度5ms,可多路异步驱动。
- 配备平面安装支架及过滤器。
- Adaptable to a full range of soft jaws and soft fingers, with precision regulators for precise adjustment of the clamping force.
- Small size, light weight, 5ms response speed, multiple asynchronous drive.
- Complete with flat mounting bracket and filter.

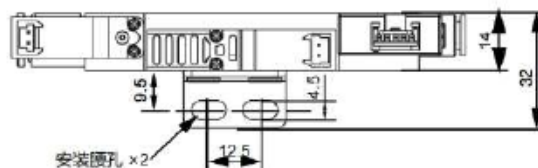
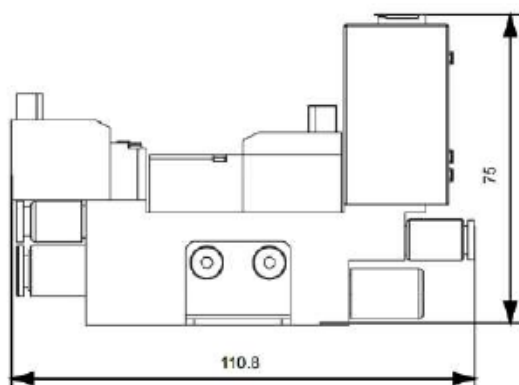
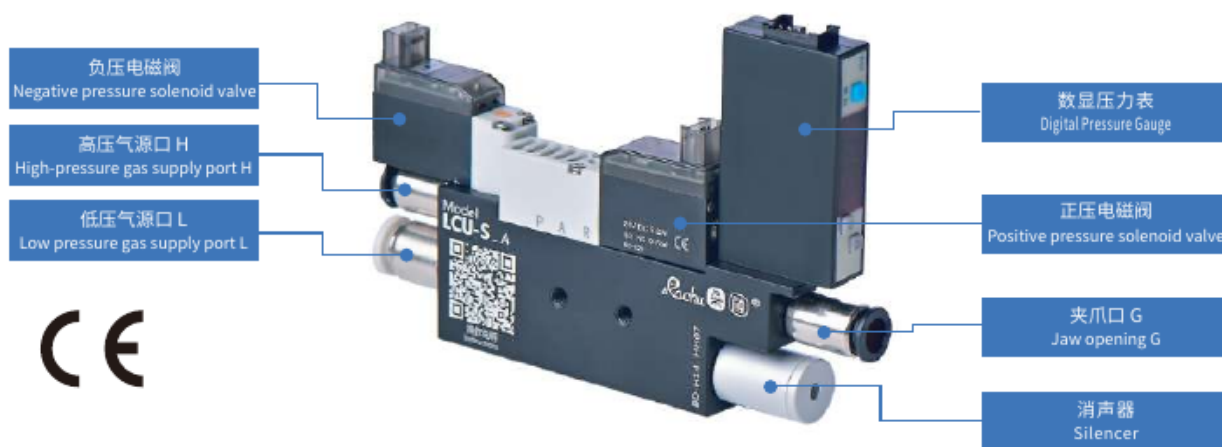

货号 PN	型号 Model	气压输出信号 Air pressure output signal	噪声 [dB] Noise [dB]	重量 Weight	尺寸 [mm] Dimensions [mm]
1.Y02564	LCU-S_A	I/O信号 I/O signals	80	127g	110.8*147*76.5

名称 Parameter	范围 Range	名称 Parameter	范围 Range
输出气压 Output air pressure	-90~300kPa	驱动模式 Drive mode	24V I/O信号驱动 24V I/O Signal Driver
电磁阀响应速度 Solenoid valve response speed	5ms	寿命 Life span	2000万次 20 million times
正压流量 Positive pressure flow	35L/min	负压流量* Negative pressure flow*	30L/min
高压气源 H 输入 High-pressure gas source H Input	0.45-0.55MPa,干燥、清洁、稳定, 流量>40L/min 0.45-0.55MPa, dry, clean and stable. Flow rate>40L/min	低压气源 L 输入 Low-pressure gas source L Input	0-300kPa,干燥、清洁、稳定 0-300kPa, dry, clean and stable

\*:该流量参数测试条件为:高压气源口H压力=0.5MPa, 低压气源口L压力=100kPa。

\*:The test conditions for this flow parameter are: high pressure gas source port H pressure = 0.5MPa, low pressure gas source port L pressure = 100kPa.

Profile- SUS Tube  
型材、钢管

Stents Module  
支架模组

Quick Changer  
快换

Grip Module  
夹具组件

Air Nipper  
气动剪刀

Vacuum Module  
真空组件

Accessory Components  
附件

# LCU-S 轻型驱动模块(标准型)

## LCU-S Light Duty Drive Module (Standard)

### 使用方式

#### Method of use

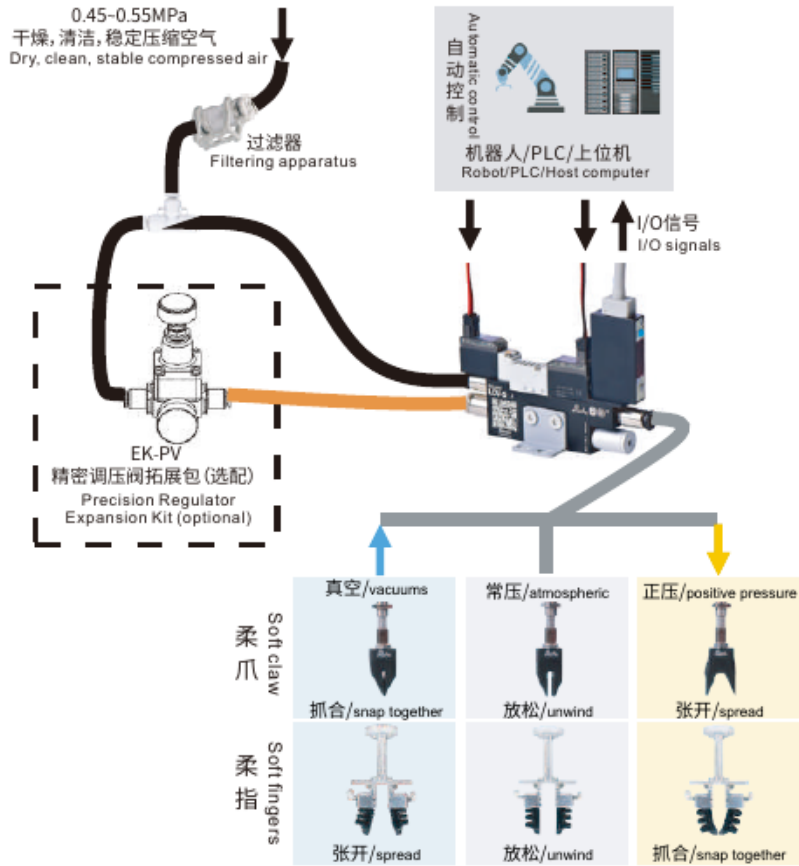

夹爪状态 Jaw status	真空 Vacuums	常压 Atmospheric	正压 Positive pressure
正压电磁阀 Positive pressure solenoid valve	断电 Power cut	断电 Power cut	通电 Open telegram
真空电磁阀 Vacuum solenoid valve	通电 Open telegram	断电 Power cut	断电 Power cut

### 安装方式

#### Installation method

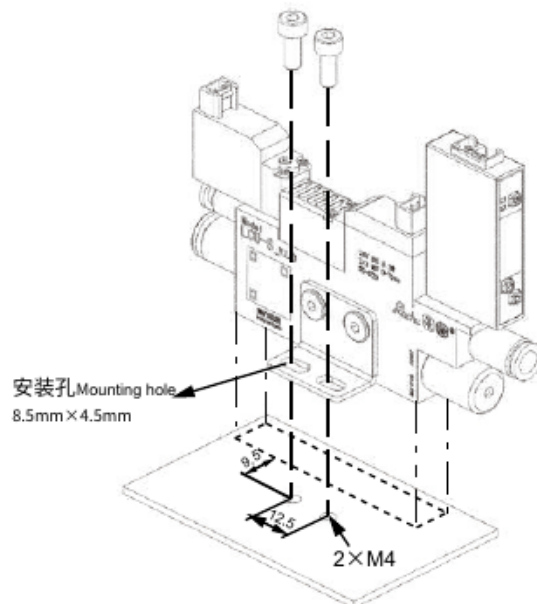

Profile, SUS Tube  
型材、钢管

Stents Module  
支架模组

Quick Changer  
快换

Grip Module  
夹具组件

Air Nipper  
气动剪刀

Vacuum Module  
真空组件

Accessory Components  
附件

# LCU-S(2~10)轻型驱动模块(组合型)

## LCU-S (2~10) Light duty drive module (combination type)

- 适配全系列柔爪和柔指,可配合精密调压阀精密调节夹持力。
- 多路异步驱动,响应速度5ms。
- 配备过滤器。
- Adaptable to a full range of soft jaws and soft fingers, with precision regulators for precise adjustment of the clamping force.
- Multi-way asynchronous drive with 5ms response speed.
- Equipped with filters.

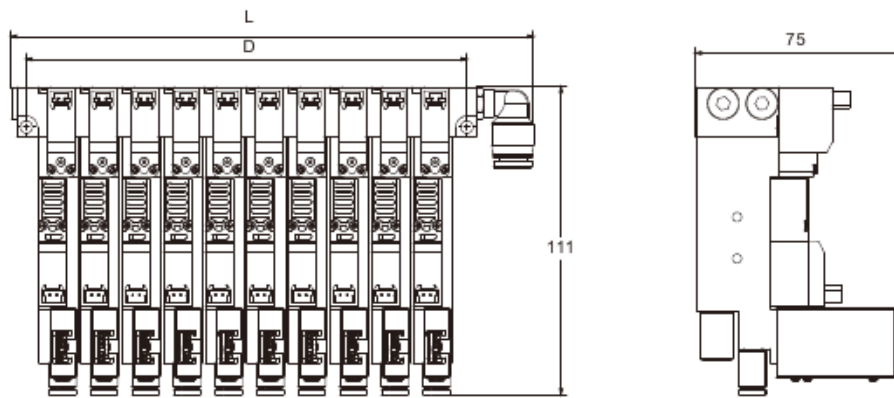
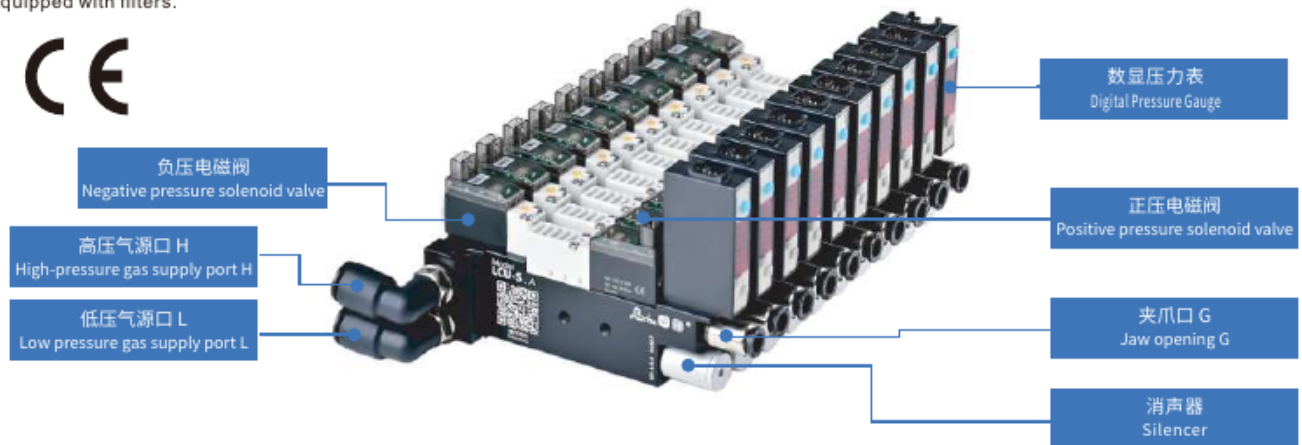

货号 PN	型号 Model	模块数量 Number of modules	D[mm]	L[mm]	噪声[dB] Noise [dB]	气压输出信号 Air pressure output signal	正压流量* [L/min] Positive pressure flow rate*	负压流量* [L/min] Negative pressure flow rate*	高压气源H 输入流量[L/min] High pressure gas source H input flow rate
1.Y02566	LCU-S2_A	2	39	74	82.5	I/O信号I/O signals	70	57	>60
1.Y02567	LCU-S3_A	3	54	89	83	I/O信号I/O signals	97	83	>85
1.Y02568	LCU-S4_A	4	69	104	84	I/O信号I/O signals	127	105	>105
1.Y02569	LCU-S5_A	5	84	119	85	I/O信号I/O signals	154	135	>140
1.Y02570	LCU-S6_A	6	99	134	86.2	I/O信号I/O signals	175	162	>165
1.Y02571	LCU-S7_A	7	114	149	86.5	I/O信号I/O signals	192	186	>190
1.Y02572	LCU-S8_A	8	129	164	86.5	I/O信号I/O signals	205	208	>210
1.Y02573	LCU-S9_A	9	144	179	87	I/O信号I/O signals	220	233	>235
1.Y02574	LCU-S10_A	10	159	194	89	I/O信号I/O signals	230	252	>255

名称 Parameter	范围 Range	名称 Parameter	范围 Range
输出气压 Output air pressure	-90~300kPa	驱动模式 Drive mode	24V I/O信号驱动 24V I/O Signal Driver
电磁阀响应速度 Solenoid valve response speed	5ms	寿命 Life span	2000万次 20 million times
高压气源H输入 High-pressure gas source H Input	0.45-0.55MPa,干燥、清洁、稳定, 0.45-0.55MPa, dry, clean and stable.	低压气源L输入 Low-pressure gas source L Input	0-300kPa,干燥、清洁、稳定 0-300kPa, dry, clean and stable

\*:该流量参数测试条件为:高压气源口H压力=0.5MPa, 低压气源口L压力=100kPa。

\*:The test conditions for this flow parameter are: high pressure gas source port H pressure = 0.5MPa, low pressure gas source port L pressure = 100kPa.

Profile- SUS Tube  
型材、钢管

Stents Module  
支架模组

Quick Changer  
快换

Grip Module  
夹具组件

Air Nipper  
气动剪刀

Vacuum Module  
真空组件

Accessory Components  
附件

# LCU-S 轻型驱动模块(标准型)

LCU-S Light Duty Drive Module (Standard)

## 使用方式

Method of use

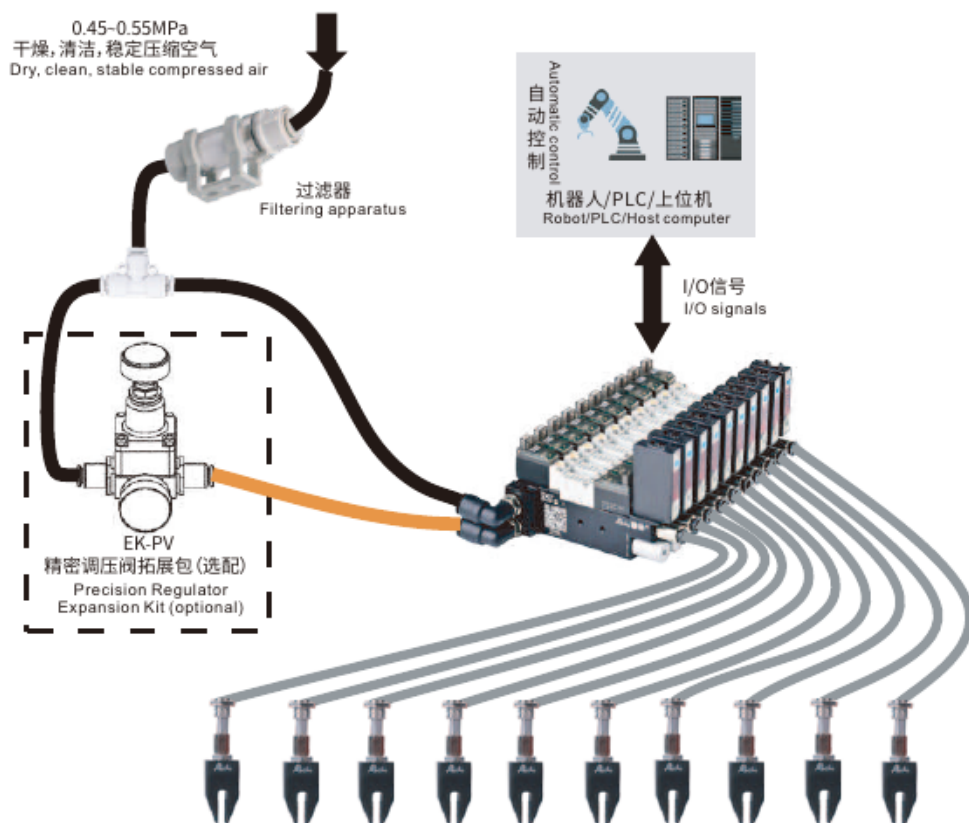

## 安装方式

Installation method

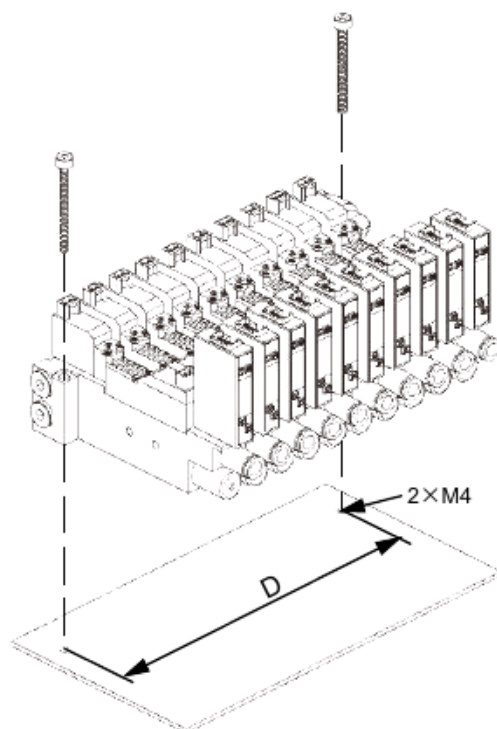

Profile, SUS Tube  
型材、钢管

Stents Module  
支架模组

Quick Changer  
快换

Grip Module  
夹具组件

Air Nipper  
气动剪刀

Vacuum Module  
真空组件

Accessory Components  
附件

# LCU-H 轻型驱动模块(高速型)

## LCU-H Light Duty Drive Module (High Speed Type)

- -85~300kPa输出气压范围, 适配全系列柔爪和柔指的驱动。
- 气缸型气动控制方式, 操作简单, 方便替换。
- 体积小, 重量轻, 可多路灵活并用组成异步驱动方式。
- 配备平面、法兰安装孔位及工业导轨卡扣, 多种安装方式。
- -85~300kPa output air pressure range, suitable for all series of soft claw and soft finger drive.
- Cylinder type pneumatic control method, simple operation, easy to replace.
- Small size, light weight, can be used flexibly to form asynchronous drive mode.
- Equipped with flat surface, flange mounting holes and industrial rail clips for multiple mounting options.

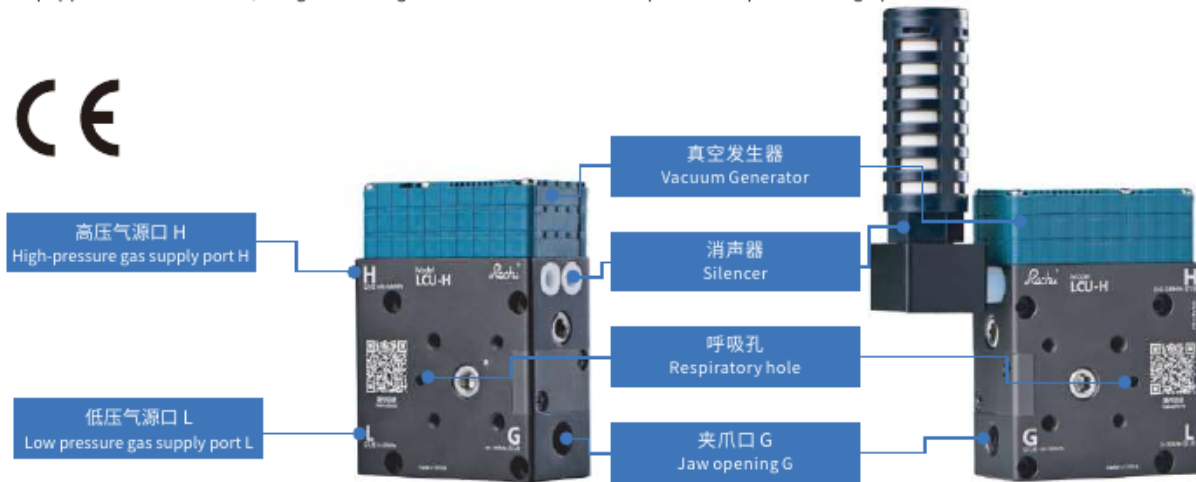

驱动器本体  
Drive Body

导轨卡扣转接板  
Guide rail snap-on adapter plate

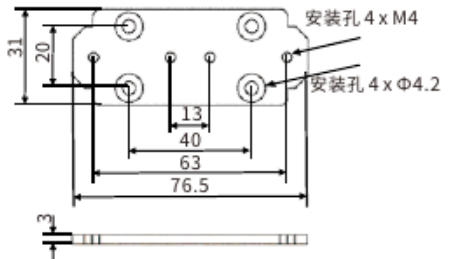
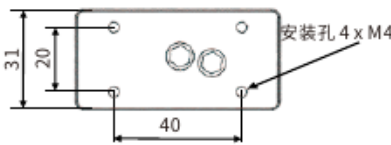
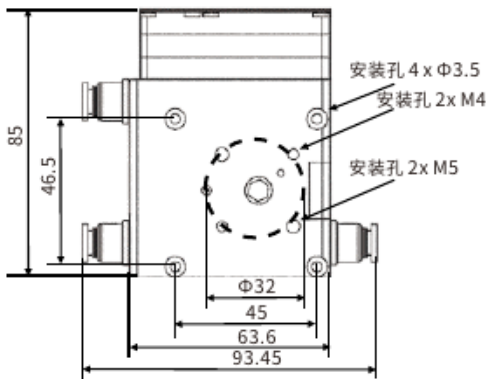

货号 PN	型号 Model	噪声[dB] Noise [dB]	重量 Weight	尺寸[mm] Dimensions [mm]
1.Y02575	LCU-H_A	92	350g	85*63.6*31
1.Y02576	LCU-H_B	72	380g	137.3*97.9*31

名称 Parameter	范围 Range	名称 Parameter	范围 Range
输出气压 Output air pressure	-90~300kPa	驱动模式 Drive mode	气控驱动 Air operated drive
电磁阀响应速度 Solenoid valve response speed	铝合金阳极氧化 Aluminium anodising	寿命 Life span	5000万次 50 million times
正压流量 Positive pressure flow	165L/min	负压流量* Negative pressure flow*	55L/min
高压气源 H 输入 High-pressure gas source H Input	0.45-0.8MPa, 干燥、清洁、稳定, 流量 > 200L/min 0.45-0.8MPa, dry, clean and stable. Flow rate > 200L/min	低压气源 L 输入 Low-pressure gas source L Input	0-300kPa, 干燥、清洁、稳定 0-300kPa, dry, clean and stable

\*:该流量参数测试条件为:高压气源口H压力=0.6MPa, 低压气源口L压力=100kPa。

\*:The test conditions for this flow parameter are: high pressure gas source port H pressure = 0.6MPa, low pressure gas source port L pressure = 100kPa.

Profile- SUS Tube  
型材、钢管

Stents Module  
支架模组

Quick Changer  
快换

Grip Module  
夹具组件

Air Nipper  
气动剪刀

Vacuum Module  
真空组件

Accessory Components  
附件

# LCU-H 轻型驱动模块(高速型)

## LCU-H Light Duty Drive Module (High Speed Type)

### 使用方式

#### Method of use

##### 两位单路驱动

Two-position single drive

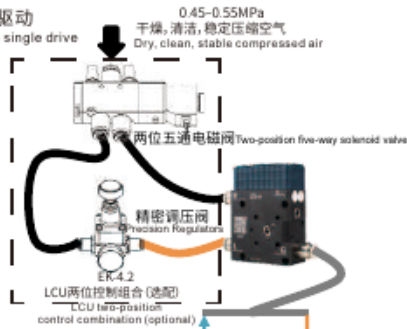

##### 三位单路驱动

There-position single drive

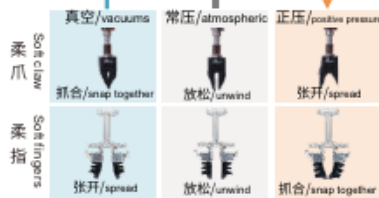
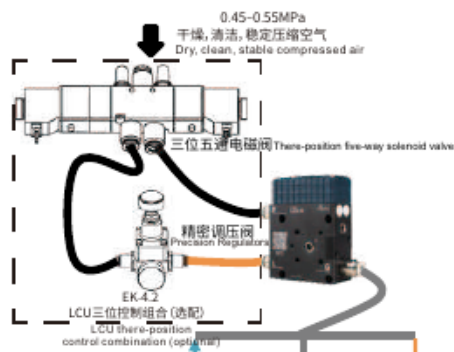

##### 多路驱动

Multi-drive

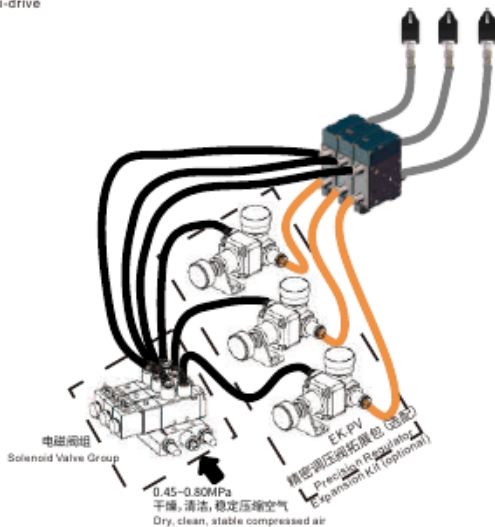

### 安装方式

#### Installation method

##### 导轨安装

Guide rail mounting

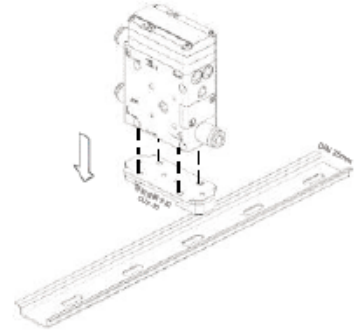

##### 底面安装

Bottom Mount

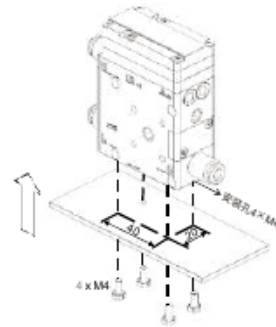

##### 侧面安装

Side mounting

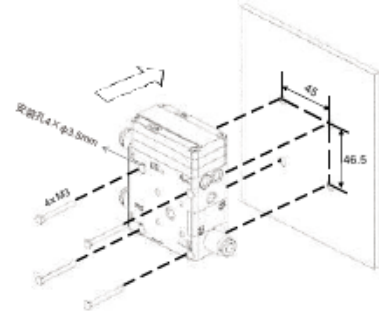

##### 侧面安装

Side mounting

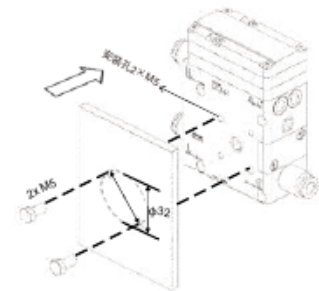

##### 侧面安装

Side mounting

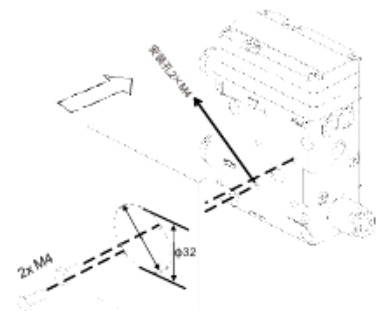

# iPCU2 无源驱动器

## iPCU2 Passive Driver

- -90~300kPa三档可调节输出气压范围,全面支持从柔爪到柔指的驱动
- 手动旋钮式调节正压;
- 一体化面板集成数显与操作按钮;
- 拥有手动(按钮)和自动(I/O电平信号)两种控制模式,适配各种机械臂、PLC等终端
- 配备安装支架及工业导轨卡扣,多种安装方式
- 拥有智能的报警功能,安全,稳定,无需担心误操作
- -90~300kPa three adjustable output air pressure range, fully support the drive from soft claw to soft finger.
- Manual knob to adjust the positive pressure.
- Integrated panel with digital display and operation buttons.
- Manual (pushbutton) and automatic (I/O level signal) control modes, compatible with all kinds of robotic arms and PLC terminals.
- Equipped with mounting bracket and industrial rail clips, a variety of installation methods.
- Intelligent alarm function, safe, stable, no need to worry about misoperation.



货号 PN	型号 Model	真空调节 Vacuum regulation	输出气压 [kPa] Output air pressure	最高真空 压力[kPa] Maximum vacuum Pressure	负压流量* [L/min] Negative pressure flow rate*	工作噪音 [dB] Operating noise	重量[kg] Weight
1.Y02560	iPCU 2-SMV 真空调压标准型 Vacuum Regulator Standard	手动 Manually operated	-85~300	-85	40	76	2.1
1.Y12927	iPCU2-SMN 无源驱动器标准型 Passive Drive Standard	不支持 Unsupported	-90~300	-90	40	75	2.0
1.Y02561	iPCU2-HMV 真空调压高速型 Vacuum-regulated high-speed type	手动 Manually operated	-85~300	-85	80	73	2.1
1.Y02562	iPCU2-HMN 无源驱动器高速型 Passive Drive High Speed Type	不支持 Unsupported	-80~300	-80	80	72	2.0

iPCU2拥有标准型和高速型两款选择,高速型拥有更大的真空流量,适用于高速搬运的情况。

\*负压流量参数测试条件:气源端压力=0.6MPa。

The iPCU2 is available in both standard and high speed options, with the high speed model having a higher vacuum flow rate for high speed handling situations.

\*Negative pressure flow parameters test conditions: pressure at the gas source end = 0.6MPa.

名称 Parameter	范围 Range	名称 Parameter	范围 Range
额定电压 Rated Voltage	24 V ± 10%	外壳材质 Fuselage Shell	工程塑料 Engineering plastics
额定功率 Rated power	12 W	尺寸 Size	208x134x141 mm
寿命 Life span	5000万次/50 million times	防护等级 Protection class	Ip54
正压调节 Positive pressure regulation	手动/Manually operated	控制方式 Control mode	1.手动按钮 1. Manual buttons
安全气压 Safe Air Pressure	可调/Tunable		2.I/O, 电平信号 2.I/O, level signals
输入气源 Input Air Source	0.45~1 Mpa, 干燥、清洁、稳定 流量>200 L/min 0.45~1 Mpa, dry, clean and stable Flow rate >200 L/min	工作模式 Work Mode	持续信号驱动 Continuous signal drive
		正压流量* Positive pressure flow*	260L/min

\*正压流量参数测试条件:气源端压力=0.6MPa, 夹爪设定正压=100kPa。

\*Positive pressure flow parameters test conditions: gas source end pressure = 0.6MPa, clamp jaw set positive pressure = 100kPa.

# iPCU2 无源驱动器

## iPCU2 Passive Driver

Profile, SUS Tube  
型材、钢管

Stents Module  
支架模组

Quick Changer  
快换

Grip Module  
夹具组件

Air Nipper  
气动剪刀

Vacuum Module  
真空组件

Accessory Components  
附件

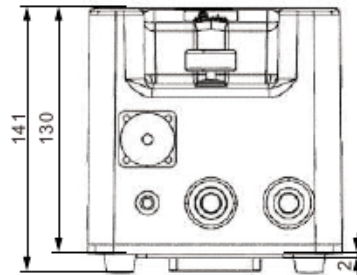
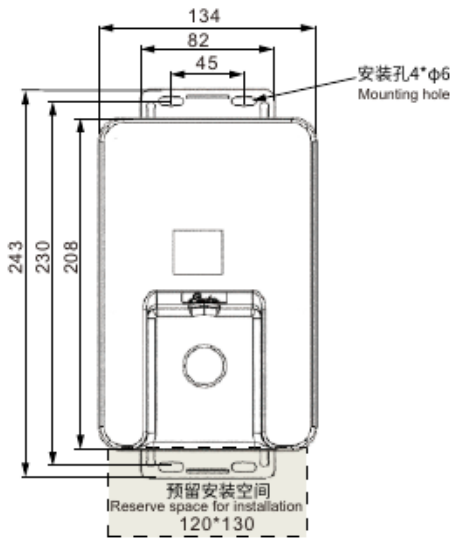

### 使用方式

#### Method of use

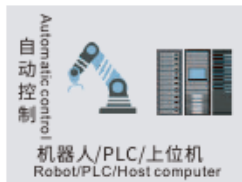

### 安装方式

#### Installation method

导轨安装  
Guide rail mounting

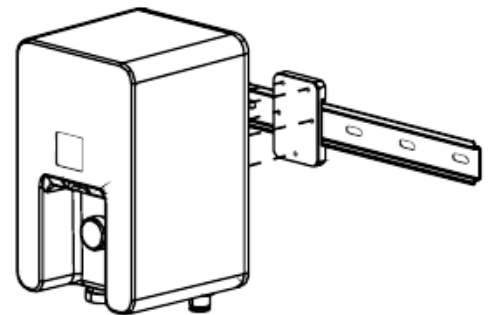

底面安装  
Bottom Mount

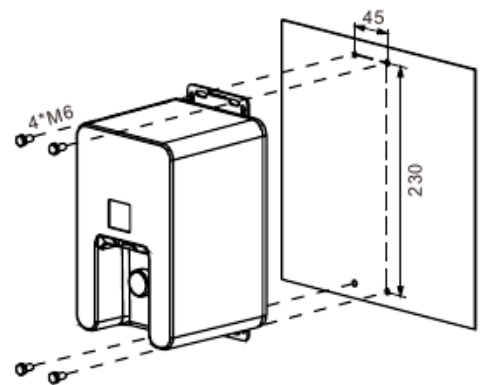

Soft claw  
Soft fingers

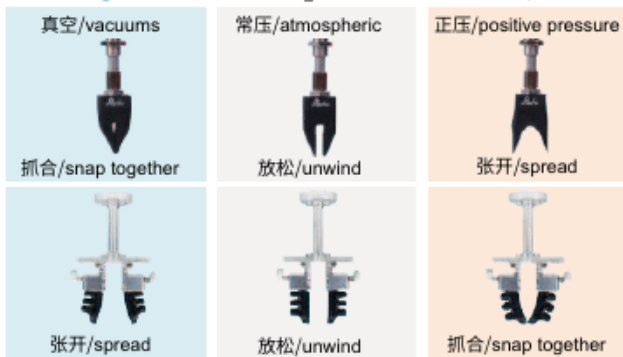

# ACU2-H 有源驱动器

## ACU2-H Active Driver

- 内置气源, 接口丰富。
- -80~280kPa输出气压范围, 适配全系列柔爪和柔指的驱动。
- 工作正压, 工作真空可通过面板按钮实时数字化调节, 输出精度±3kPa。
- 一体化面板集成数显与操作按钮。
- 拥有手动(按钮)、I/O、模拟量以及MODBUS多种控制模式, 适配各种机械臂, PLC终端。
- 产品通过欧盟CE安全认证。
- Built-in air source with abundant interfaces.
- -80~280kPa output air pressure range, suitable for all series of soft claw and soft finger drive.
- Positive working pressure, working vacuum can be digitally adjusted in real time through the panel button, output accuracy ±3kPa.
- Integrated panel with digital display and operating buttons.
- With manual (button), I/O, analogue and MODBUS control modes, with a variety of robotic arms, PLC terminals.
- Products through the European Union CE safety certification.



货号(PN)	型号(Model)
8.Y02563	ACU2-H

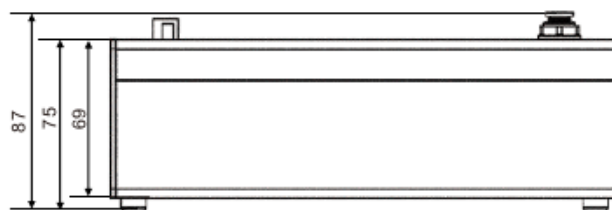
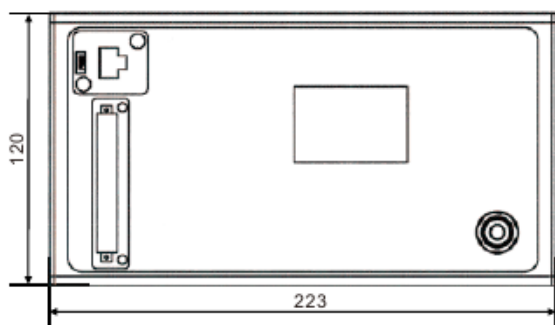

名称 Parameter	范围 Range	名称 Parameter	范围 Range
额定电压 Rated Voltage	24 VDC ± 10%	外壳材质 Fuselage Shell	铝合金阳极氧化 Aluminium alloy anodising
额定功率 Rated power	48W	尺寸 Size	120x223x75 mm
寿命 Life span	5000小时/5000 hours	重量 Weight	1.8kg
输出气压 Output air pressure	-80~280kPa	防护等级 Protection class	IP54
输出精度 Output accuracy	±3kPa	控制方式 Control mode	1. 手动按钮 1. Manual button
正压流量 Positive pressure flow	8 L/min		2. I/O, 电平信号 2. I/O, level signals
真空流量 Vacuum flow	8 L/min		3. 电压模拟量调节压力 3. Voltage analogue regulation of pressure
工作噪音 Operating noise	50dB		4. MODBUS TCP/RTU
工作模式 Operating mode	持续信号驱动 Continuous signal drive		

型材、钢管  
Profile、SUS Tube

支架模组  
Stents Module

快换  
Quick Changer

夹具组件  
Grip Module

气动剪刀  
Air Nipper

真空组件  
Vacuum Module

附件  
Accessory Components

# ACU2-H 有源驱动器

ACU2-H Active Driver

## 使用方式

Method of use

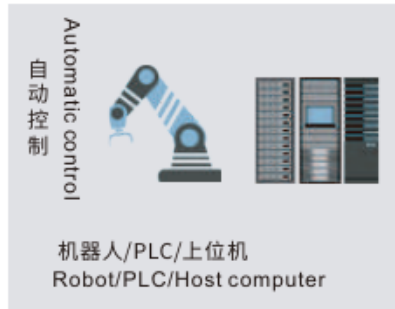

Manual debugging  
手动调试



面板按钮  
Panel button

I/O信号 I/O signals



真空/vacuums



抓合/snap together

常压/atmospheric



放松/unwind

正压/positive pressure



张开/spread

Soft claw  
柔爪



张开/spread



放松/unwind



抓合/snap together

Soft fingers  
柔指

Profile, SUS Tube  
型材、钢管

Stents Module  
支架模组

Quick Changer  
快换

Grip Module  
夹具组件

Air Nipper  
气动剪刀

Vacuum Module  
真空组件

Accessory Components  
附件

# 膨胀器

## Expansion Gripper

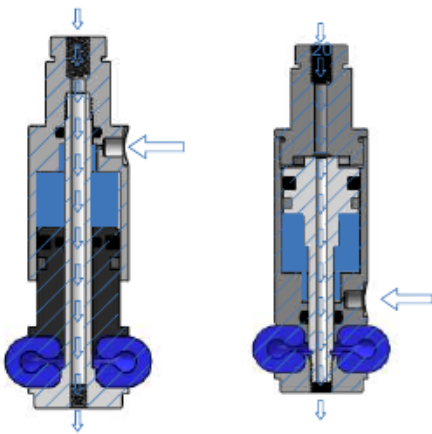

GBD...HD

GBD...HU

向下或向上。

橡皮圈部分可由硅橡胶制成。

夹取尺寸可从18到31 mm不等。

多种安装附件。

Downward movement, or Upward movement.

The elastic part can be in Silicone or Rubber.

Grip diameters from 18 to 31 mm.

Several mounting accessories.

过孔

H型号拥有一个中央过孔。可吹送压缩空气，或通过冷却部件或检查泄露的方式提供真空。

Through hole for fastening

The ...H models have a central through hole. It can be used to blow compressed air, or to provide vacuum, with the purpose to cool a part or to check the leakage.

### 型号表示方法

#### Model representation methods

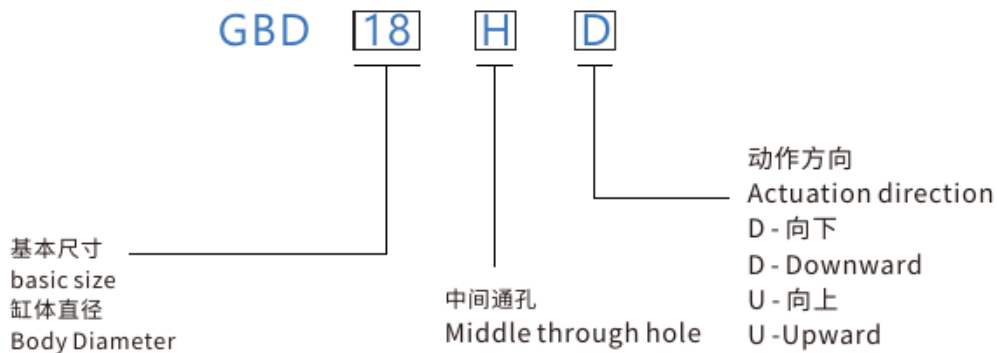

Profile- SUS Tube  
型材、钢管

Stents Module  
支架模组

Quick Changer  
快换

Grip Module  
夹具组件

Air Nipper  
气动剪刀

Vacuum Module  
真空组件

Accessory Components  
附件

# 鼓胀器

## Expansion Gripper

Profile, SUS Tube  
型材、钢管

Stents Module  
支架模组

Quick Changer  
快换

Grip Module  
夹具组件

Air Nipper  
气动剪刀

Vacuum Module  
真空组件

Accessory Components  
附件

### GBD...HU

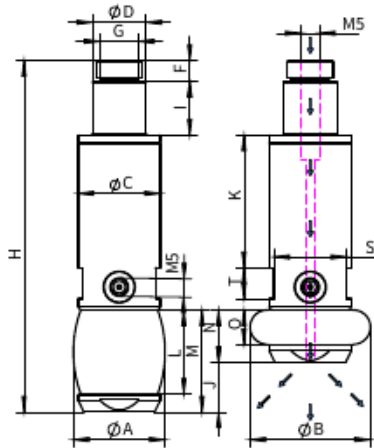

### GBD...U

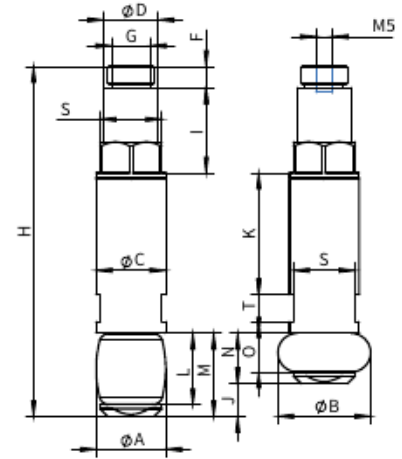

货号(PN)	型号(Model)	ØA	ØB	ØC	ØD	F	G	H	I	J	K	L	M	N	O	S	T	重量(Weight)
8.Y00212	GBD18U	18	24	18	14	5.5	M12×1	90.5	22	8.5	31.5	18.5	21.5	13	10	16	7	39.7g
8.Y00058	GBD22HU	24	31.5	21.3	14	5.5	M12×1	92	14	13	34.8	22	26.7	13.7	9	19	8	53.8g

### GBD...HD

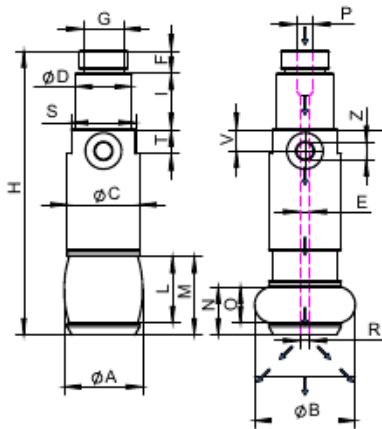

货号(PN)	型号(Model)	ØA	ØB	ØC	ØD	ØE	F	G	H	I	L	M	N	O	P	R	S	T	V	Z	重量(Weight)
8.Y00057	GBD18HD	19.5	25	18	14	2.5	5.5	M12×1	70.5	14	16.5	19.5	12	9	M5	M3	16	6	5.3	M5	27.4g
8.Y01256	GBD25HD	29	36	25	20	2.5	8	M17×1	101.5	20	24.5	28.5	17.7	13.7	G1/8	M3	22	6	8	M5	85.3g

# 鼓胀器

## Expansion Gripper

### 硅橡胶

#### Silicone rubber

橡胶圈部分采用蓝色硅橡胶或透明硅橡胶。

硅橡胶可提供较高的温度范围,确保较长的使用寿命。

硅橡胶(蓝色或透明)橡胶圈可作为备件,磨损后可替换。

硅橡胶制成的橡胶圈预计可使用100万次。

The elastic part can be in blue Silicone, or transparent silicone.

Silicone can be used over a wider temperature range and assures a longer life time.

The elastic part in Silicone is available as a spare part and can be replaced, when worn out.

The expected medium life time of the elastic part in Silicone is about 1 million cycles.

### 备用的橡胶圈部件

#### Spare elastic part



橡胶圈出货时可有客户选定  
Silicone can be shipped by customers

规格(Spec.)	Ø18	Ø22
型号(Model)	18-S1	22-S1
货号(PN)	4.Y00470	4.Y00471
型号(Model)	18-S2	22-S2
货号(PN)	4.Y00472	4.Y00473
鼓胀器(Bulging device)	GBD18U GBD18HD	GBD22HU

T-橡胶圈部件的操作温度(夹具主体5~60°C)

T - Operating temperature of the elastic part (5~60°C for the gripper body)



# 卡扣夹具

## Clip Fixture

功能: 夹取  
 优点: 双作用气缸, 磁性检测  
 应用场景: 用于相关卡扣夹取和装配

Function: Clamping  
 Advantages: Double-Acting Cylinder, Magnetic Sensor Detection  
 Application scenario: For clip clamping and assembly



卡扣  
Clip



夹紧  
Clamped

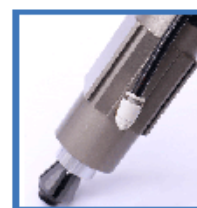

松开  
Released

货号(PN)	8.Y01249
型号(Model)	GNT-4017

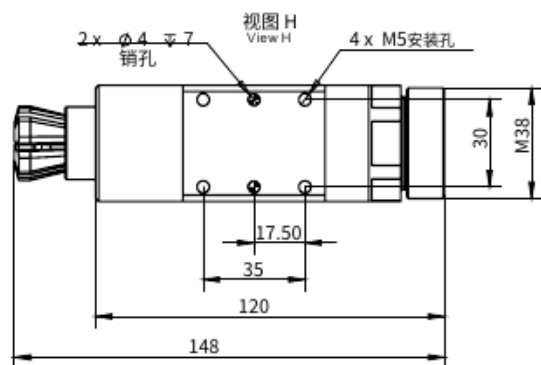
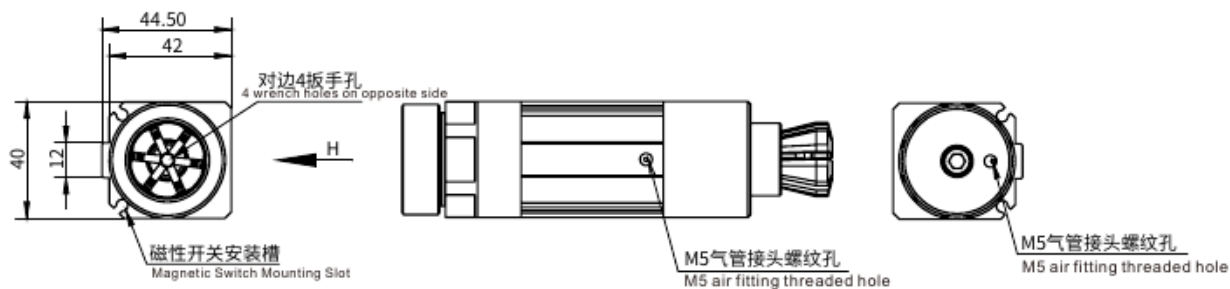

Profile, SUS Tube  
型材、钢管

Stents Module  
支架模组

Quick Changer  
快换

Clip Module  
夹具组件

Air Nipper  
气动剪刀

Vacuum Module  
真空组件

Accessory Components  
附件

# 缓冲支架

## Buffer Support

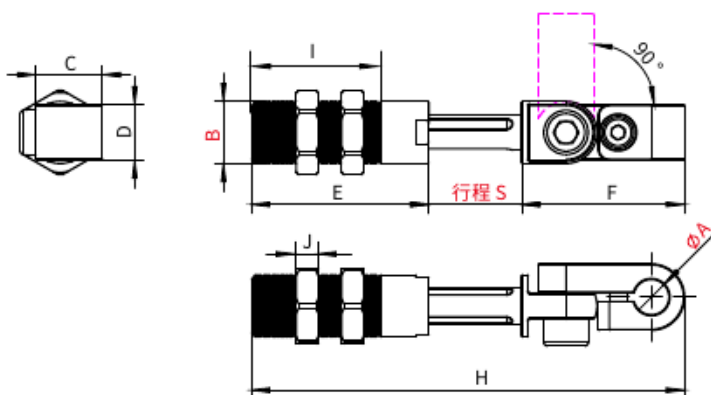

货号(PN)	型号(Model)	A(mm)	B(mm)	C(mm)	D(mm)	E(mm)	F(mm)	H(mm)	I(mm)	J(mm)	S(mm)	重量(Weight)
8.Y00242	GSRT1421-08	8	M14	15	12.5	40	36.75	97.75	29	2.7	21	43g
8.Y00332	GSRT2026-10	10	M20	20	15	50	45.5	121.5	39	3.9	26	92g
8.Y00244	GSRT2026-12	12	M20	20	15	50	45.5	121.5	39	3.9	26	91g
8.Y00333	GSRT2051-10	10	M20	20	15	84	45.5	180.5	39	3.9	51	129g
8.Y00334	GSRT2051-12	12	M20	20	15	84	45.5	180.5	39	3.9	51	128g

尺寸(mm) / Dimensions (mm)

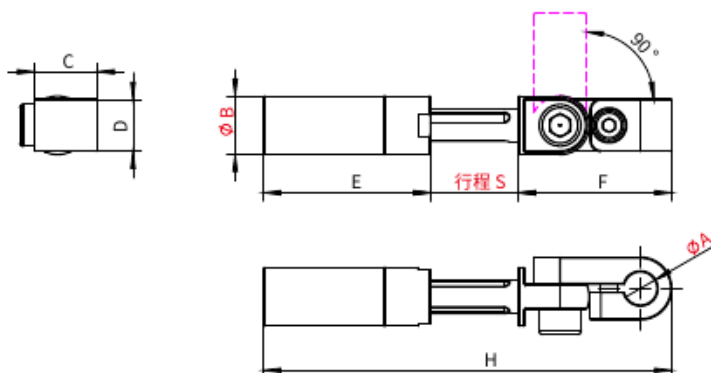

货号(PN)	型号(Model)	A(mm)	B(mm)	C(mm)	D(mm)	E(mm)	F(mm)	H(mm)	S(mm)	重量(Weight)
8.Y00241	GSR1421-08	8	14	15	12.5	40	36.75	97.75	21	36g
8.Y00373	GSR1436-10	10	14	20	15	60	45.5	139	36.5	54g
8.Y00329	GSR2026-10	10	20	20	15	50	45.5	121.5	26	74g
8.Y00243	GSR2026-12	12	20	20	15	50	45.5	121.5	26	73g
8.Y00330	GSR2051-10	10	20	20	15	84	45.5	180.5	51	111g
8.Y00331	GSR2051-12	12	20	20	15	84	45.5	180.5	51	110g

尺寸(mm) / Dimensions (mm)

Profile- SUS Tube  
型材、钢管

Stents Module  
支架模组

Quick Changer  
快换

Grip Module  
夹具组件

Air Nipper  
气动剪刀

Vacuum Module  
真空组件

Accessory Components  
附件

# 缓冲支架

## Buffer Support

Profile、SUS Tube  
型材、钢管

Stents Module  
支架模组

Quick Changer  
快换

Grip Module  
夹具组件

Air Nipper  
气动剪刀

Vacuum Module  
真空组件

Accessory Components  
附件



无传感器(Without Sensor)

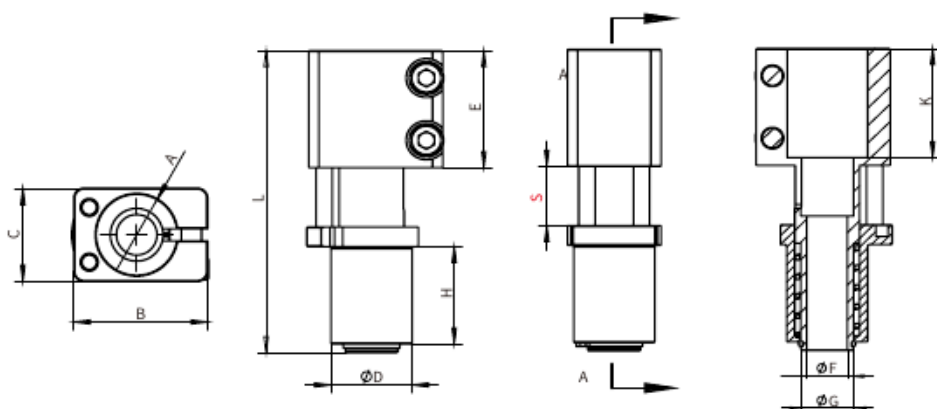

货号(PN)	型号(Model)	A	B	C	D	E	F	G	H	L	K	S	重量(Weight)
8.Y00238	GSP20-14	14	31	20	20	30	10	13	25	77.5	28	15	57g
8.Y00239	GSP20-20	20	33	23	20	30	10	13	25	77.5	28	15	65g
8.Y01032	GSP30-30	30	43	33	30	30	14	22	25	77.5	28	15	108g

尺寸(mm) / Dimensions (mm)



传感器选配(Sensor Option)

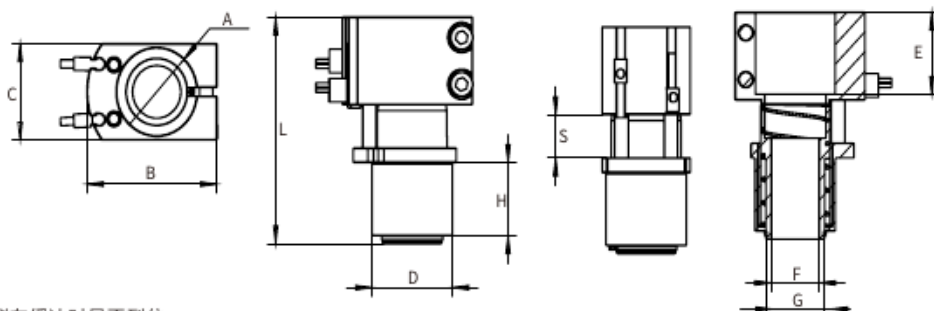

1. 可以通过调节传感器的检测位置, 来检测在缓冲时是否到位。
  2. 可以实现自动化生产中的闭环功能。
1. The position of the sensor can be adjusted to detect whether the buffer is in place or not.
  2. The closed-loop function can be realized in automatic production.

货号(PN)	型号(Model)	A	B	C	D	E	F	G	H	L	S	重量(Weight)
8.Y01079	GSP20-20C	20	38.5	23	20	28	Ø10	Ø12.5	25	77.5	15	80g
8.Y01081	GSP30-30C	30	48.6	33	30	30	Ø14	Ø22	25	77.5	15	103g

尺寸(mm) / Dimensions (mm)

产品颜色以实物为准 Product color is based on the actual product

# 模具定位器

## Mould Positioner



货号(PN)	型号(Model)	A	B	D	E	F	G	H	I	J	K	最大锁持力 Maximum holding force	重量(Weight)
8.Y00408	GMP14A	38	14	M12*1	-	12	5	4	Ø14	Ø11	M5	90N	62g
8.Y00088	GMP20A	46	25	M17*1	19	18	10	9	Ø20	Ø15.5	G1/8	190N	78g
8.Y00089	GMP30A	75	38	M27*1	28	27	11	10	Ø30	Ø25.5	G1/8	280N	303g

尺寸(mm) / Dimensions (mm)

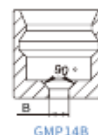
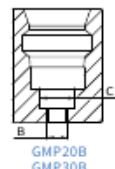
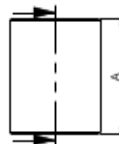

货号(PN)	型号(Model)	A	B	C	D	重复精度 (Repetition accuracy)	重量(Weight)
7.Y00968	GMP14B	15	M4(或orM3沉头)	-	15.5h7	±0.015	46g
7.Y00726	GMP20B	33	M6(或orM5沉头)	10	26h7	±0.015	87g
7.Y00789	GMP30B	43.5	M8(或orM6沉头)	11	40h7	±0.015	264g

尺寸(mm) / Dimensions (mm)

Profile- SUS Tube  
型材、钢管

Stents Module  
支架模组

Quick Changer  
快换

Grip Module  
夹具组件

Air Nipper  
气动剪刀

Vacuum Module  
真空组件

Accessory Components  
附件

# 模具定位器

## Mould Positioner

Profile, SUS Tube  
型材、钢管

Stents Module  
支架模组

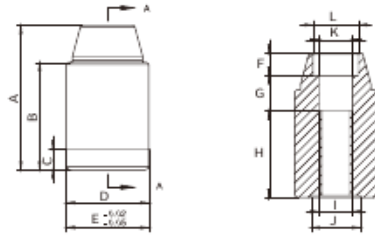

货号(PN)	型号(Model)	A	B	C	D	E	F	G	H	I	J	K	L	重量(Weight)
7.Y00894	GLU20A	35	26	5	Ø19.92	Ø20	5.50	8.50	21	M8	Ø12	Ø8.20	Ø11	61g

尺寸(mm) / Dimensions (mm)

Quick Changer  
快换

Grip Module  
夹具组件

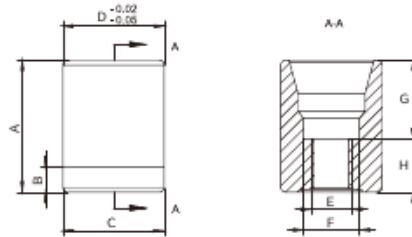

货号(PN)	型号(Model)	A	B	C	D	E	F	G	H	重量(Weight)
7.Y00895	GLU20B	26	5	Ø19.92	Ø20	M8	Ø11	15.50	10.50	42g

Air Nipper  
气动剪刀

Vacuum Module  
真空组件

Accessory Components  
附件

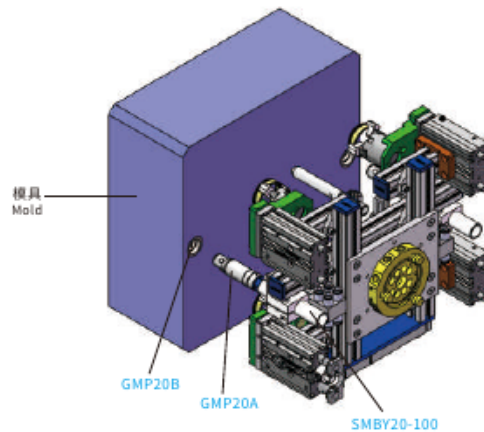

## 气动针夹 (GN系列)

### Pneumatic Needle Gripper (Series GN)

多用于汽车行业的无纺布埋入,也可用于网布、海绵等物体的取出或埋入。

钢针的伸出长度可调节,且可以根据客户要求定制非标的钢针长度。

Being used for embedding and taking out nonwoven fabric, net cloth and sponge. The length of the steel needle can be not only adjustable, but also customized according to the requirements of the customer.



GN2010-8S51  
8针 Pins



GN2010-S51  
4针 Pins



GN2010-S21  
4针 Pins



GN2010  
4针 Pins



GN2010-8  
8针 Pins



GN3003-4  
4针 Pins



GN3003-4-15  
4针 Pins



GN2002-32  
32针 Pins

Profile- SUS Tube  
型材、钢管

Stents Module  
支架模组

Quick Changer  
快换

Grip Module  
夹具组件

Air Nipper  
气动剪刀

Vacuum Module  
真空组件

Accessory Components  
附件

压力范围 Pressure range	温度范围 Temperature range	6 bar压力下打开气缸力 Opening total gripping force at 6 bar	针状行程S Needle stroke s	循环空气消耗量 Cycle air consumption
3 ~ 8 bar	-10° ~ 70 °C.	90 N	0 ~ 10 mm	3.5 cm <sup>3</sup>

## GN2010-8S51

### 8针 Pins

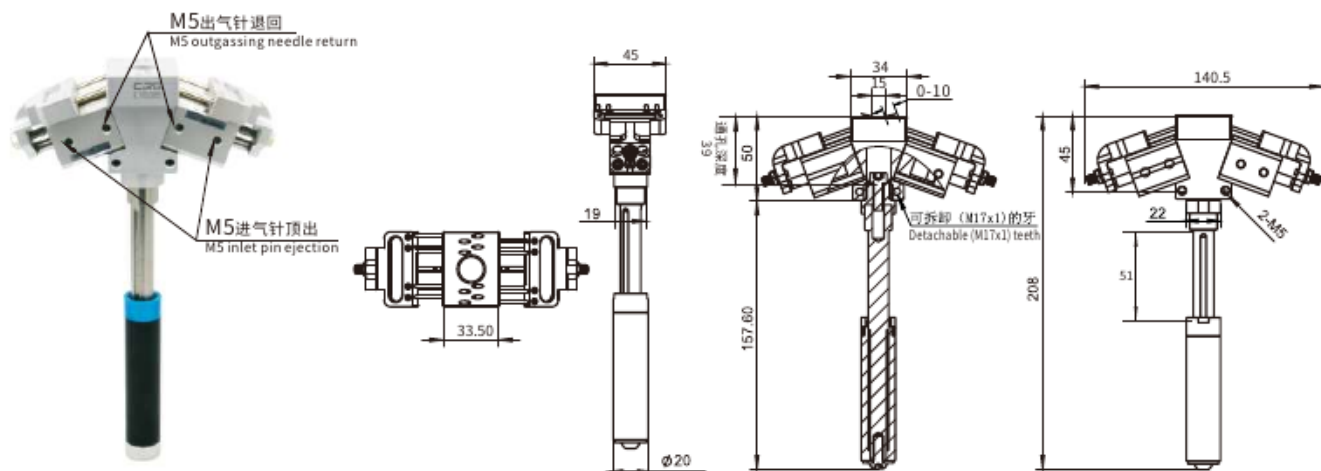

## GN2010-S51

### 4针 Pins

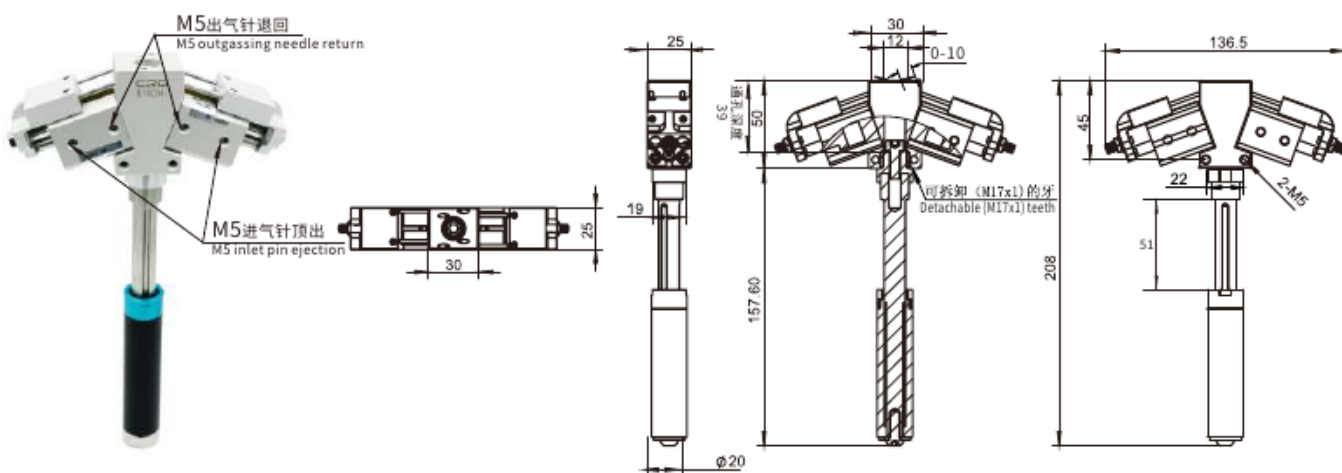

## GN2010-S21

### 4针 Pins

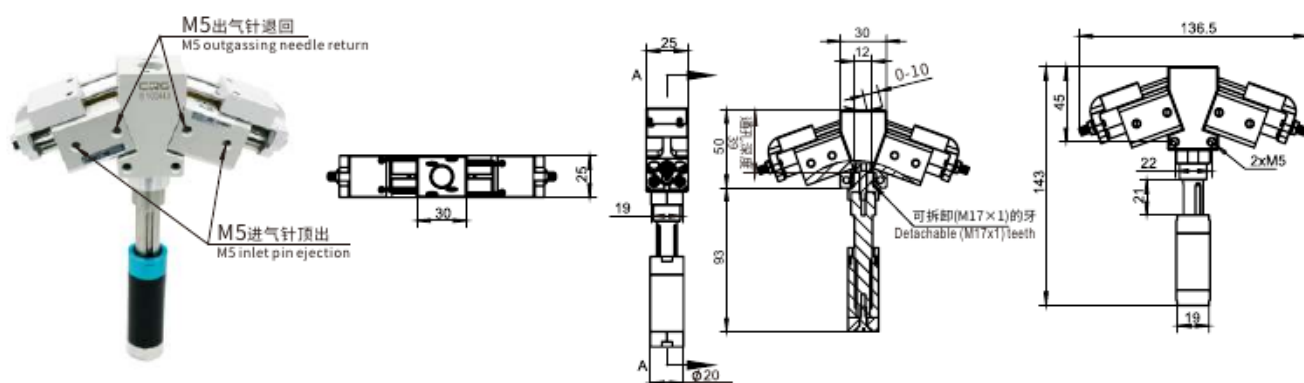

货号(PN)	8.Y00341	8.Y00440	8.Y00385
型号(Model)	GN2010-S51	GN2010-S21	GN2010-8S51
重量Weight	426g	369g	480g

# 气动针夹 (GN系列)

## Pneumatic Needle Gripper (Series GN)

多用于汽车行业的无纺布埋入,也可用于网布、海绵等物体的取出或埋入。

钢针的伸出长度可调节,且可以根据客户要求定制非标的钢针长度。

Being used for embedding and taking out nonwoven fabric, net cloth and sponge. The length of the steel needle can be not only adjustable, but also customized according to the requirements of the customer.

### GN2010

#### 4针 Pins

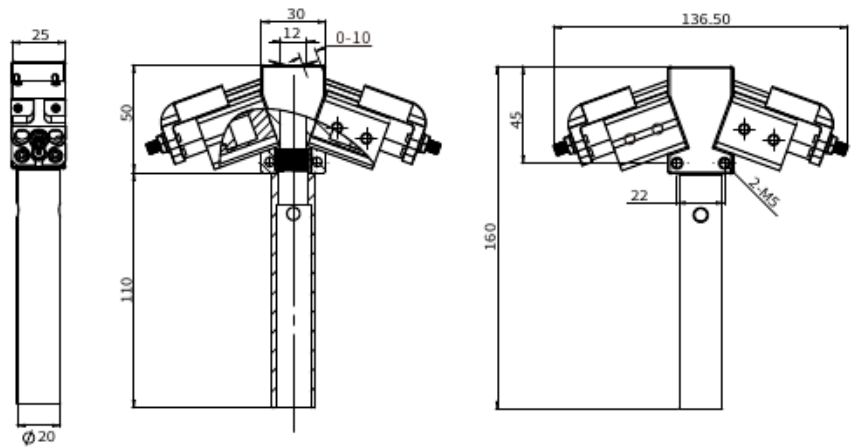

### GN2010-8

#### 8针 Pins

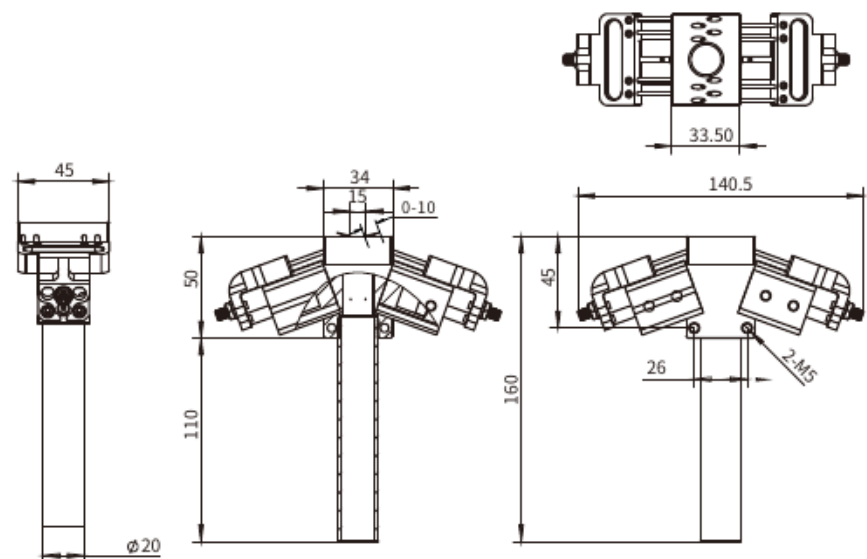

货号(PN)	8.Y00025	8.Y00347
型号(Model)	GN2010	GN2010-8
重量Weight	274g	317g

Profile- SUS Tube  
型材、钢管

Stents Module  
支架模组

Quick Changer  
快换

Grip Module  
夹具组件

Air Nipper  
气动剪刀

Vacuum Module  
真空组件

Accessory Components  
附件

# 气动针夹 (GN系列)

## Pneumatic Needle Gripper (Series GN)

小针头插入深度浅,可快速释放,搬运薄型气型工件  
处理难以用真空吸附的材料,如复合纺织品,羊毛,  
过滤器,编织玻璃纤维或碳纤维,编织芳族聚酰胺,泡沫材料等

Small needle insertion depth is shallow, Can quickly release, transport thin breathable workpiece,  
Processing difficult to vacuum adsorption of materials,  
such as composite textiles, wool, filters, woven glass or carbon fiber,  
woven aramid, foam, etc.

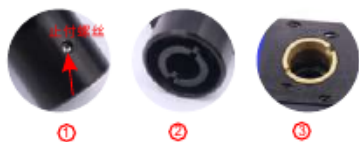

### 针长调节说明

使用六角扳手拧出止付螺丝①  
用硬币或其他物品对准卡槽旋转调节针长②  
顶部铜材质更加耐磨,更换方便③

### Needle Length Adjustment Instructions

Use a hex wrench to unscrew the stop screw. ①  
Adjust the needle length by rotating it with a coin or other object against the slot. ②  
Copper top is more wear-resistant and easy to replace. ③

GN3003-4  
4针 Pins

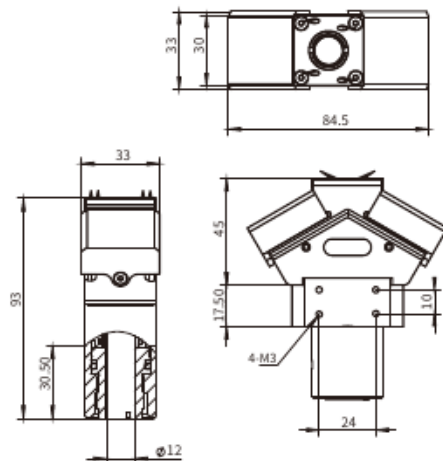
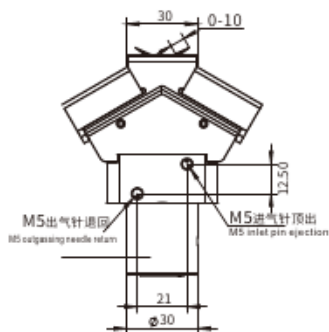

GN3003-8  
8针 Pins

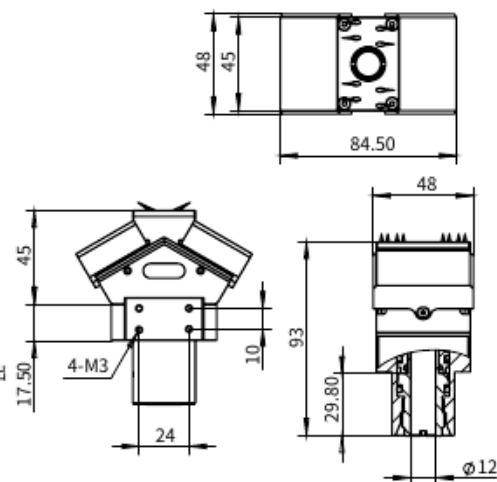
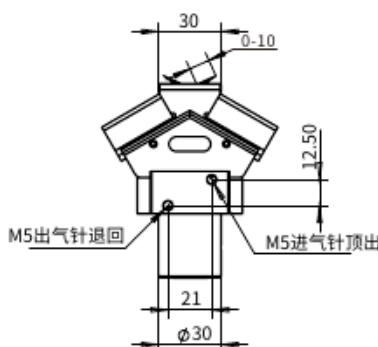

货号(PN)	8.Y01005	8.Y01250
型号(Model)	GN3003-4	GN3003-8
重量Weight	188g	285g

# 气动针夹 (GN系列)

## Pneumatic Needle Gripper (Series GN)

小针头插入深度浅,可快速释放

搬运薄型气型工件

可调节针的行程

处理难以用真空吸附的材料,如复合纺织品,羊毛,

过滤器,编织玻璃纤维或碳纤维,编织芳族聚酰胺,泡沫材料等

可以通过调节传感器的检测位置,来检测在缓冲时是否到位。

可以实现在自动化生产中的闭环功能。

Small needle insertion depth is shallow

Can quickly release, transport thin breathable workpiece,

Can adjust the needle stroke,

Processing difficult to vacuum adsorption of materials, such as composite textiles, wool, filters, woven glass or carbon fiber, woven aramid, foam, etc.

The position of the sensor can be adjusted to detect whether the buffer is in place or not.

The closed-loop function can be realized in automatic production.

GN3003-4-15

4针 Pins

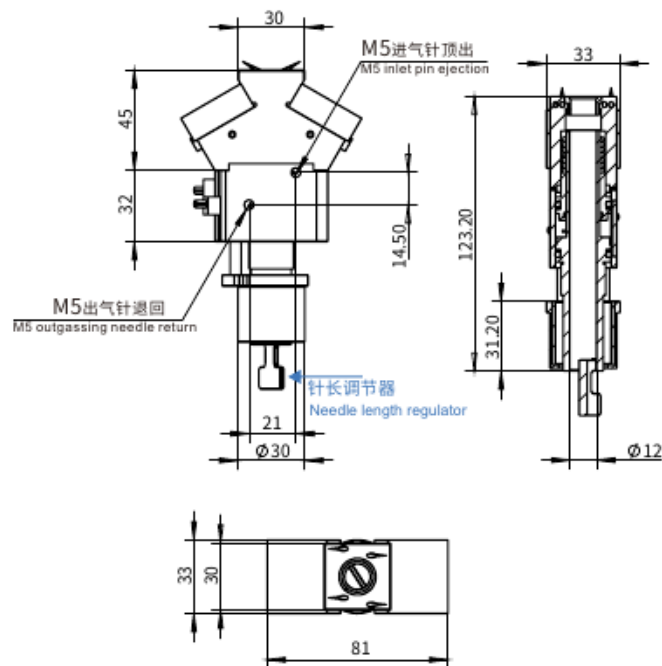

货号 PN	型号 Model	重量 Weight	弹簧力 Spring force	固定锁紧力 Fixed locking force	针状行程S Needle stroke s	缓冲行程 Buffer trip
8.Y01082	GN3003-4-15	275g	18.7N	8.2N.m	0 ~ 10 mm	0-15mm

型材、钢管  
Profile, SUS Tube

支架模组  
Stents Module

快换  
Quick Changer

夹具组件  
Grip Module

气动剪刀  
Air Nipper

真空组件  
Vacuum Module

附件  
Accessory Components

# 气动针夹 (GN系列)

## Pneumatic Needle Gripper (Series GN)

小针头插入深度浅,可快速释放  
 搬运薄型气型工件  
 可调节针的行程  
 处理难以用真空吸附的材料,如复合纺织品,羊毛,  
 过滤器,编织玻璃纤维或碳纤维,编织芳族聚酰胺,泡沫材料等

Small needle insertion depth is shallow  
 Can quickly release, transport thin breathable workpiece,  
 Can adjust the needle stroke,  
 Processing difficult to vacuum adsorption of materials,  
 such as composite textiles, wool, filters, woven glass or carbon fiber,  
 woven aramid, foam, etc.

GN2002-32  
 32针 Pins



针可一排一排换  
 The Needles can be changed row by row

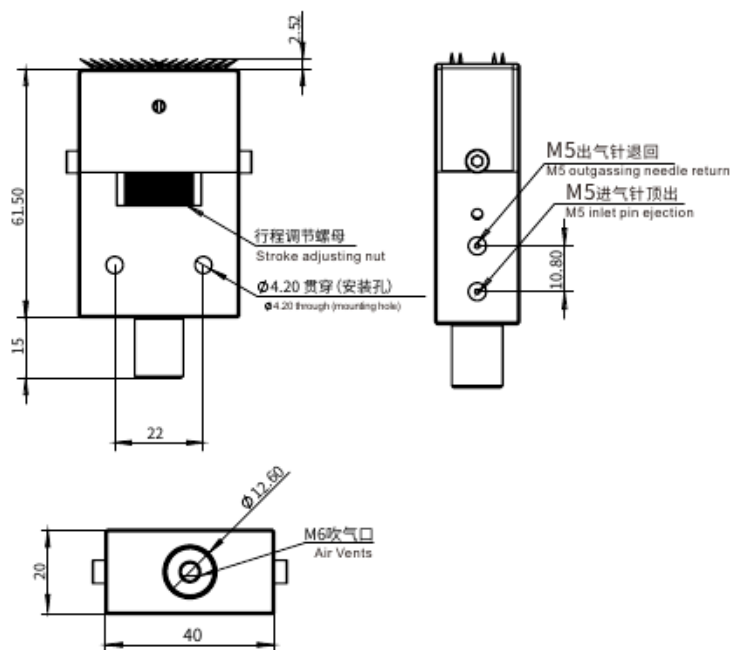

货号 PN	型号 Model	重量 Weight	钢针数量 Number of steel needles	钢针直径 Needle diameter	工作压力 Working pressure	工作温度 Operating temperature	行程 stroke
8.Y01035	GN2002-32	100g	32	0.7mm	3-6Bar	5-60°C	2mm

Profile, SUS Tube  
 型材、钢管

Stents Module  
 支架模组

Quick Changer  
 快换

Grip Module  
 夹具组件

Air Nipper  
 气动剪刀

Vacuum Module  
 真空组件

Accessory Components  
 附件

## 单动拨指 (GFA系列)

### One Finger Angular Pneumatic Grippers (Series GFA)

针对表面位置比较小, 不利于吸取和夹取的产品。  
嵌件治具配套模具定位器使用, 可以更高精度的定位,  
降低自动化项目对于机械手精度的要求。  
单一动作, 内置磁环。

For small surface position, not conducive to the absorption and clamping of the product.  
The embedded fixture is matched with the mould locator, so it can locate with higher precision,  
Reduce the precision requirement of manipulator in automation project.  
Single action, built-in Magnetic Loop

GFA...-35

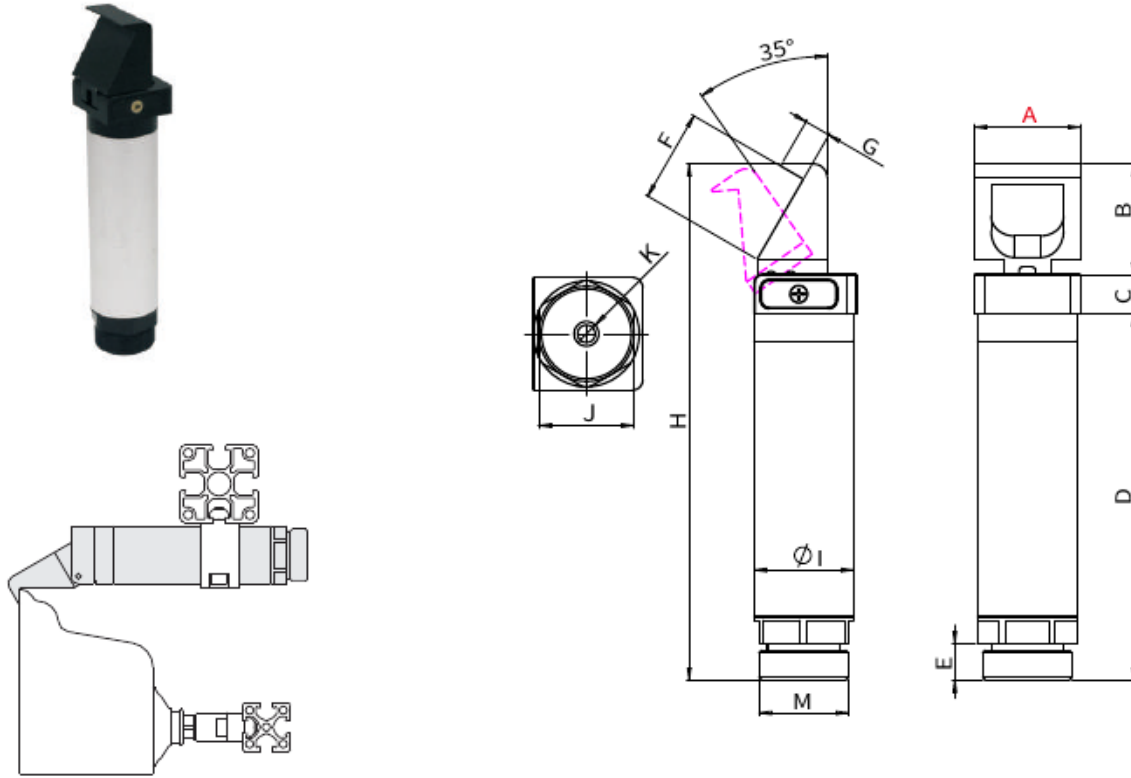

货号 PN	型号 Model	压力范围 Pressure range	温度范围 Temperature range	行程 Stroke	活塞孔 Piston bore	6 bar压力下的 关闭扭矩 Closing torque at 6 bar	循环空气 消耗量 Cycle air consumption	内置磁环 Built-in magnetic ring
8.Y00117	GFA14-35	2.5 ~ 8 bar	-10 ~ 70 °C	35°	Ø10 mm	26 Ncm	0.4 cm <sup>3</sup>	✓
8.Y00118	GFA20-35				Ø16 mm	100 Ncm	1.24 cm <sup>3</sup>	✓
8.Y00119	GFA30-35				Ø25 mm	430 Ncm	4.56 cm <sup>3</sup>	✓

货号 PN	型号 Model	重量 Weight	A	B	C	D	E	F	G	H	I	J	K	M
8.Y00117	GFA14-35	25g	14	14	10.5	49.5	5.5	13.5	4.5	74	Ø14	12	M5	M12×1
8.Y00118	GFA20-35	65g	20	20.5	9	76.5	8	20.2	6	106	Ø20	17	M5	M17×1
8.Y00119	GFA30-35	206g	30	30	12	111	11	30.5	8	153	Ø30	27	G1/8	M27×1

Profile- SUS Tube  
型材、钢管

Stents Module  
支架模组

Quick Changer  
快换

Grip Module  
夹具组件

Air Nipper  
气动剪刀

Vacuum Module  
真空组件

Accessory Components  
附件

## 单动拨指 (GFR系列)

### One Finger Angular Pneumatic Grippers (Series GFR)

针对表面位置比较小, 不利于吸取和夹取的产品。  
嵌件治具配套模具定位器使用, 可以更高精度的定位,  
降低自动化项目对于机械手精度的要求。  
单一动作, 内置磁环。

For small surface position, not conducive to the absorption and clamping of the product.  
The embedded fixture is matched with the mould locator, so it can locate with higher precision,  
Reduce the precision requirement of manipulator in automation project.  
Single action, built-in Magnetic Loop

GFR...-95

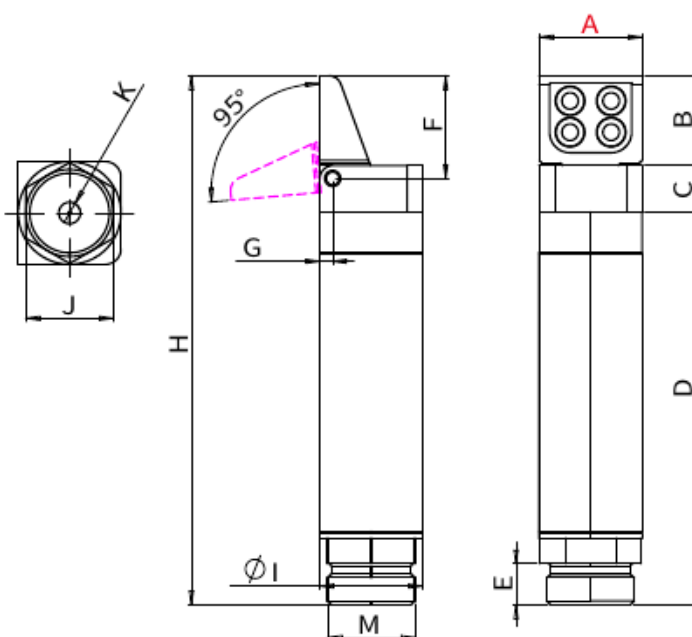
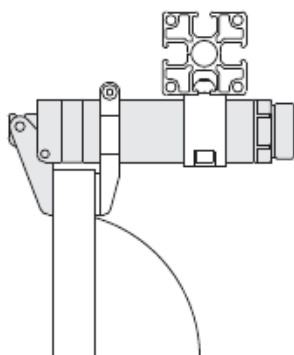

货号 PN	型号 Model	压力范围 Pressure range	温度范围 Temperature range	行程 Stroke	活塞孔 Piston bore	6 bar压力下的 关闭扭矩 Closing torque at 6 bar	循环空气 消耗量 Cycle air consumption	内置磁环 Built-in magnetic ring
8.Y00042	GFR14-95	2.5 ~ 8 bar	-10 ~ 70 °C	95°	Ø10 mm	19 Ncm	1 cm <sup>3</sup>	✓
8.Y00311	GFR20-95E				Ø16 mm	70 Ncm	3.52 cm <sup>3</sup>	✓
8.Y00095	GFR30-95				Ø25 mm	300 Ncm	12.9 cm <sup>3</sup>	✓

货号 PN	型号 Model	重量 Weight	A	B	C	D	E	F	G	H	I	J	K	M
8.Y00042	GFR14-95	25g	14	12	10.5	49.5	5.5	14	2	72	Ø14	12	M5	M12×1
8.Y00311	GFR20-95E	60g	20	17.5	9	76.5	8	20	2.5	103	Ø20	17	M5	M17×1
8.Y00095	GFR30-95	193g	30	25	12	111	11	29	4	148	Ø30	27	G1/8	M27×1

# 单动拨指 (GFR系列)

## One Finger Angular Pneumatic Grippers (Series GFR)

针对表面位置比较小, 不利于吸取和夹取的产品。  
嵌件治具配套模具定位器使用, 可以更高精度的定位,  
降低自动化项目对于机械手精度的要求。  
单一动作, 内置磁环。

For small surface position, not conducive to the absorption and clamping of the product.  
The embedded fixture is matched with the mould locator, so it can locate with higher precision,  
Reduce the precision requirement of manipulator in automation project.  
Single action, built-in Magnetic Loop

GFR...-95G

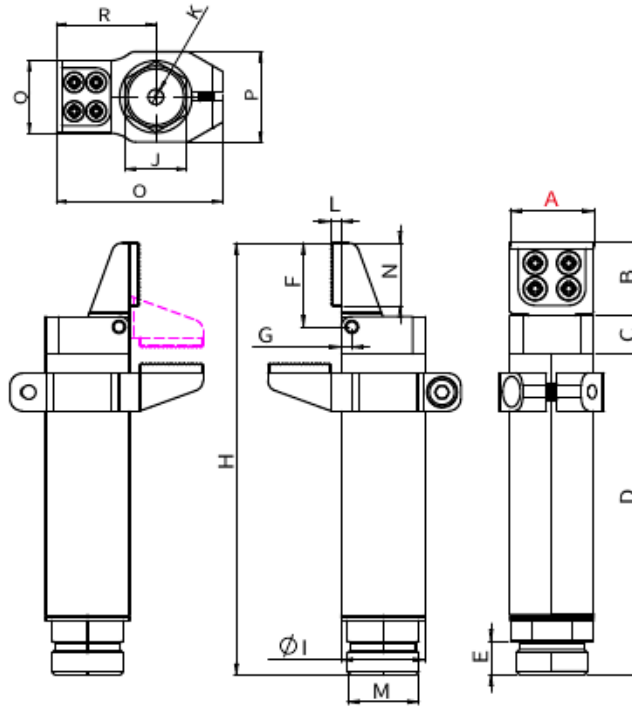
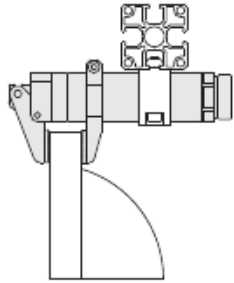

货号 PN	型号 Model	压力范围 Pressure range	温度范围 Temperature range	行程 Stroke	活塞孔 Piston bore	6 bar压力下的 关闭扭矩 Closing torque at 6 bar	循环空气 消耗量 Cycle air consumption	内置磁环 Built-in magnetic ring
8.Y00084	GFR14-95G	2.5 ~ 8 bar	-10 ~ 70 °C	95°	Ø10 mm	19 Ncm	1 cm <sup>3</sup>	✓
8.Y00312	GFR20-95EG				Ø16 mm	70 Ncm	3.52 cm <sup>3</sup>	✓
8.Y00096	GFR30-95G				Ø25 mm	300 Ncm	12.9 cm <sup>3</sup>	✓

货号 PN	型号 Model	重量 Weight	A	B	C	D	E	F	G	H	I	J	K	M	N	O	P	Q	R
8.Y00084	GFR14-95G	36g	14	12	10.5	49.5	5.5	14	2	72	Ø14	12	M5	M12×1	11	32	19	14	19
8.Y00312	GFR20-95EG	87g	20	17.5	9	76.5	8	20	2.5	103	Ø20	17	M5	M17×1	15	46	25	20	27.5
8.Y00096	GFR30-95G	300g	30	25	12	111	11	29	4	148	Ø30	27	G1/8	M27×1	20	63	37	30	40

Profile、SUS Tube  
型材、钢管

Stents Module  
支架模组

Quick Changer  
快换

Grip Module  
夹具组件

Air Nipper  
气动剪刀

Vacuum Module  
真空组件

Accessory Components  
附件

## 单动拨指 (GFR系列)

### One Finger Angular Pneumatic Grippers (Series GFR)

针对表面位置比较小, 不利于吸取和夹取的产品。  
嵌件治具配套模具定位器使用, 可以更高精度的定位,  
降低自动化项目对于机械手精度的要求。  
单一动作, 内置磁环。

For small surface position, not conducive to the absorption and clamping of the product.  
The embedded fixture is matched with the mould locator, so it can locate with higher precision,  
Reduce the precision requirement of manipulator in automation project.  
Single action, built-in Magnetic Loop

GFR...-95S

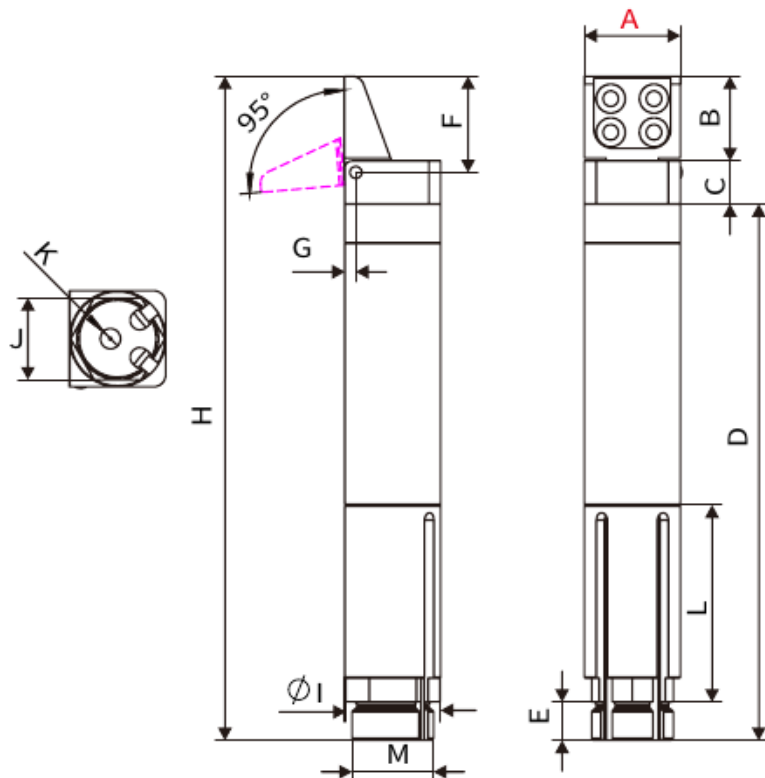
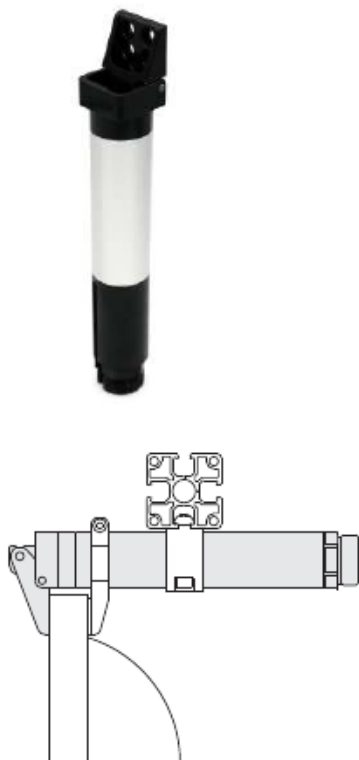

货号 PN	型号 Model	压力范围 Pressure range	温度范围 Temperature range	行程 Stroke	活塞孔 Piston bore	6 bar压力下的 关闭扭矩 Closing torque at 6 bar	循环空气 消耗量 Cycle air consumption	内置磁环 Built-in magnetic ring
8.Y00335	GFR20-95S	2.5 ~ 8 bar	-10 ~ 70 °C	95°	Ø16 mm	70 Ncm	3.52 cm <sup>3</sup>	✓
8.Y01273	GFR30-95S				Ø25 mm	300 Ncm	12.9 cm <sup>3</sup>	✓

货号 PN	型号 Model	重量 Weight	A	B	C	D	E	F	G	H	I	J	K	L	M
8.Y00335	GFR20-95S	89g	20	17.5	9	111.5	8	20	2.3	138	Ø20	17	M5	41	M17×1
8.Y01273	GFR30-95S	239g	30	25	12	145	11	29	/	182	Ø30	27	M5	49	M27×1

# 单动拨指 (GFR系列)

## One Finger Angular Pneumatic Grippers (Series GFR)

针对表面位置比较小, 不利于吸取和夹取的产品。  
嵌件治具配套模具定位器使用, 可以更高精度的定位,  
降低自动化项目对于机械手精度的要求。  
单一动作, 内置磁环。

For small surface position, not conducive to the absorption and clamping of the product.  
The embedded fixture is matched with the mould locator, so it can locate with higher precision,  
Reduce the precision requirement of manipulator in automation project.  
Single action, built-in Magnetic Loop

GFR...-95SG

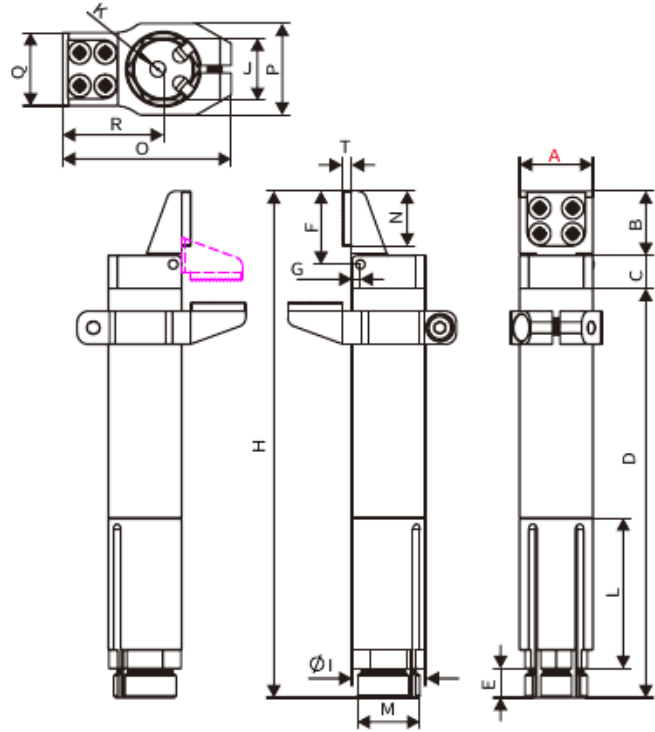
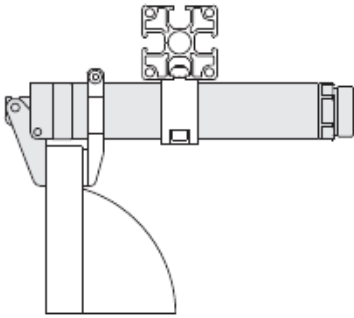

货号 PN	型号 Model	压力范围 Pressure range	温度范围 Temperature range	行程 Stroke	活塞孔 Piston bore	6 bar压力下的 关闭扭矩 Closing torque at 6 bar	循环空气 消耗量 Cycle air consumption	内置磁环 Built-in magnetic ring
8.Y00336	GFR20-95SG	2.5 ~ 8 bar	-10 ~ 70 °C	95°	Ø16 mm	70 Ncm	3.52 cm <sup>3</sup>	✓
8.Y01301	GFR30-95SG				Ø25 mm	300 Ncm	12.9 cm <sup>3</sup>	✓

货号 PN	型号 Model	重量 Weight	A	B	C	D	E	F	G	H	I	J	K	L	M	N	O	P	Q	R	T
8.Y00336	GFR20-95SG	104.8g	20	17.5	9	111.5	8	20	2.3	138	Ø20	17	M5	41	M17×1	15	46	25	20	27.5	2.5
8.Y01301	GFR30-95SG	269g	30	25	20	137	11	29	4	182	Ø30	27	M5	49	M27×1	20	63	37	30	40	3.5

Profile- SUS Tube  
型材、钢管

Stents Module  
支架模组

Quick Changer  
快换

Grip Module  
夹具组件

Air Nipper  
气动剪刀

Vacuum Module  
真空组件

Accessory Components  
附件

## 单动拨指 (GFR系列)

### One Finger Angular Pneumatic Grippers (Series GFR)

针对表面位置比较小, 不利于吸取和夹取的产品。  
嵌件治具配套模具定位器使用, 可以更高精度的定位,  
降低自动化项目对于机械手精度的要求。  
单一动作, 内置磁环。

For small surface position, not conducive to the absorption and clamping of the product.  
The embedded fixture is matched with the mould locator, so it can locate with higher precision,  
Reduce the precision requirement of manipulator in automation project.  
Single action, built-in Magnetic Loop

GFR...-95L

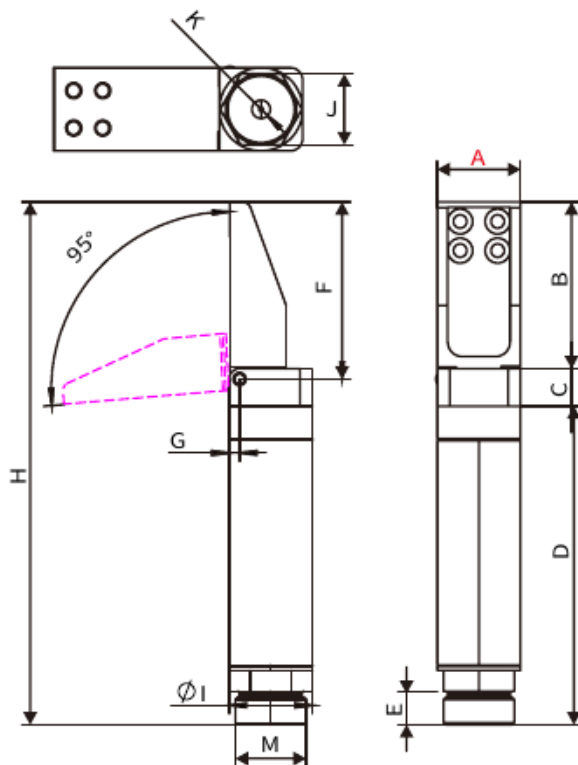

货号 PN	型号 Model	压力范围 Pressure range	温度范围 Temperature range	行程 Stroke	活塞孔 Piston bore	6 bar压力下的 关闭扭矩 Closing torque at 6 bar	循环空气 消耗量 Cycle air consumption	内置磁环 Built-in magnetic ring
8.Y00309	GFR20-95L	2.5 ~ 8 bar	-10 ~ 70 °C	95°	Ø16 mm	70 Ncm	3.52 cm <sup>3</sup>	✓
8.Y01006	GFR30-95L				Ø25 mm	300 Ncm	12.9 cm <sup>3</sup>	✓

货号 PN	型号 Model	重量 Weight	A	B	C	D	E	F	G	H	I	J	K	M
8.Y00309	GFR20-95L	81.4g	20	40	9	76.3	8	42.5	2.5	125.5	Ø20	17	M5	M17×1
8.Y01006	GFR30-95L	206.3g	30	51.5	20	103	11	55.5	4	174.5	Ø30	27	G1/8	M27×1

# 单动拨指 (GFR系列)

## One Finger Angular Pneumatic Grippers (Series GFR)

针对表面位置比较小, 不利于吸取和夹取的产品。  
嵌件治具配套模具定位器使用, 可以更高精度的定位,  
降低自动化项目对于机械手精度的要求。  
单一动作, 内置磁环。

For small surface position, not conducive to the absorption and clamping of the product.  
The embedded fixture is matched with the mould locator, so it can locate with higher precision,  
Reduce the precision requirement of manipulator in automation project.  
Single action, built-in Magnetic Loop

GFR...-95LG

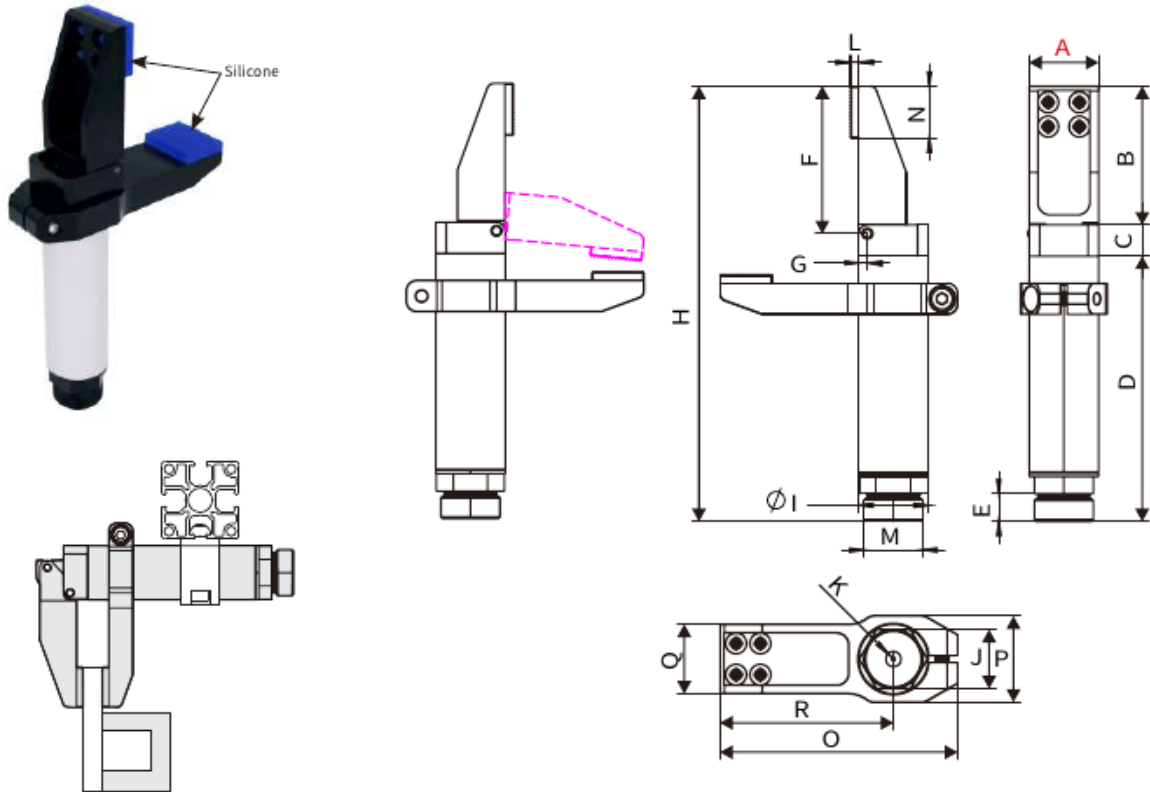

货号 PN	型号 Model	压力范围 Pressure range	温度范围 Temperature range	行程 Stroke	活塞孔 Piston bore	6 bar压力下的 关闭扭矩 Closing torque at 6 bar	循环空气 消耗量 Cycle air consumption	内置磁环 Built-in magnetic ring
8.Y00310	GFR20-95LG	2.5 ~ 8 bar	-10 ~ 70 °C	95°	Ø16 mm	70 Ncm	3.52 cm <sup>3</sup>	✓
8.Y01299	GFR30-95LG				Ø25 mm	300 Ncm	12.9 cm <sup>3</sup>	✓

货号 PN	型号 Model	重量 Weight	A	B	C	D	E	F	G	H	I	J	K	M	N	O	P	Q	R
8.Y00310	GFR20-95LG	104.8g	20	40	9	76.5	8	42.5	2.5	125.5	Ø20	17	M5	M17×1	15	68.5	25	20	50
8.Y01299	GFR30-95LG	258g	30	51.5	20	103	11	55.5	4	174.5	Ø30	27	G1/8	M27×1	20	88	37	30	65

Profile- SUS Tube  
型材、钢管

Stents Module  
支架模组

Quick Changer  
快换

Grip Module  
夹具组件

Air Nipper  
气动剪刀

Vacuum Module  
真空组件

Accessory Components  
附件

## 单动拨指 (GFS系列)

### One Finger Angular Pneumatic Grippers (Series GFS)

针对表面位置比较小, 不利于吸取和夹取的产品。  
嵌件治具配套模具定位器使用, 可以更高精度的定位,  
降低自动化项目对于机械手精度的要求。  
单一动作, 内置磁环。

For small surface position, not conducive to the absorption and clamping of the product.  
The embedded fixture is matched with the mould locator, so it can locate with higher precision,  
Reduce the precision requirement of manipulator in automation project.  
Single action, built-in Magnetic Loop

GFS...-90G

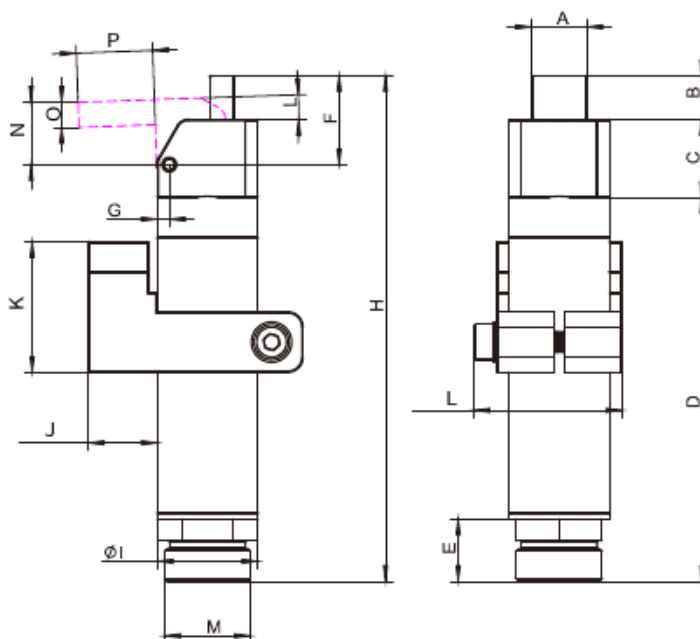

货号 PN	型号 Model	压力范围 Pressure range	温度范围 Temperature range	行程 Stroke	活塞孔 Piston bore	6 bar压力下的 关闭扭矩 Closing torque at 6 bar	循环空气 消耗量 Cycle air consumption	内置磁环 Built-in magnetic ring
8.Y01001	GFS14-90G	2.5 ~ 8 bar	-10 ~ 70 °C	90°	Ø10 mm	19 Ncm	1 cm <sup>3</sup>	✓
8.Y01002	GFS20-90G				Ø16 mm	70 Ncm	3.52 cm <sup>3</sup>	✓
8.Y01003	GFS30-90G				Ø25 mm	300 Ncm	12.9cm <sup>3</sup>	✓

货号 PN	型号 Model	重量 Weight	A	B	C	D	E	F	G	H	I	J	K	L	M	N	O	P
8.Y01001	GFS14-90G	34g	8	6.7	10.5	49.5	5.5	6	2	66.8	Ø14	9	12	22.5	M12×1	8.5	4	10.8
8.Y01002	GFS20-90G	83g	11	8.7	15.5	76.4	8	17.7	2.4	100.6	Ø20	13.7	26	29.5	M17×1	12.4	5	15.2
8.Y01003	GFS30-90G	296g	14	13.7	23.5	111	11	29.5	4	139.2	Ø30	23.7	26	66	M27×1	20	6	25.2

## 单动拨指 (GF系列)

### One Finger Angular Pneumatic Grippers (Series GF)

针对表面位置比较小, 不利于吸取和夹取的产品。  
嵌件治具配套模具定位器使用, 可以更高精度的定位,  
降低自动化项目对于机械手精度的要求。  
单一动作, 内置磁环。

For small surface position, not conducive to the absorption and clamping of the product.  
The embedded fixture is matched with the mould locator, so it can locate with higher precision,  
Reduce the precision requirement of manipulator in automation project.  
Single action, built-in Magnetic Loop

GFS...-90SG

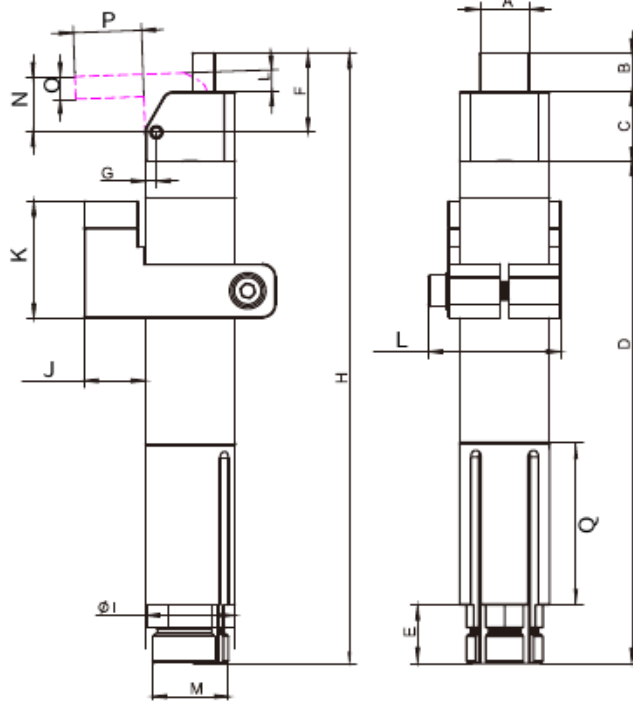

货号 PN	型号 Model	压力范围 Pressure range	温度范围 Temperature range	行程 Stroke	活塞孔 Piston bore	6 bar压力下的 关闭扭矩 Closing torque at 6 bar	循环空气 消耗量 Cycle air consumption	内置磁环 Built-in magnetic ring
8.Y01030	GFS20-90SG	2.5 ~ 8 bar	-10 ~ 70 °C	90°	Ø16 mm	70 Ncm	3.52 cm <sup>3</sup>	✓
8.Y01031	GFS30-90SG				Ø25 mm	300 Ncm	12.9cm <sup>3</sup>	✓

货号 PN	型号 Model	重量 Weight	A	B	C	D	E	F	G	H	I	J	K	L	M	N	O	P	Q
8.Y01030	GFS20-90SG	99g	11	8.7	15.5	112	8	17.7	2.4	136.2	Ø20	13.7	26	29.5	M17×1	12.37	5	15.2	36
8.Y01031	GFS30-90SG	312g	14	13.7	23.5	147	11	29.2	4	184.2	Ø30	23.7	26	66	M27×1	20	6	25.2	49

Profile- SUS Tube  
型材、钢管

Stents Module  
支架模组

Quick Changer  
快换

Grip Module  
夹具组件

Air Nipper  
气动剪刀

Vacuum Module  
真空组件

Accessory Components  
附件

## 拨指选件

### Finger Grippers Options

#### 硅胶垫片

#### Silicone gasket

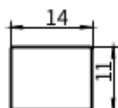

SIL-14G

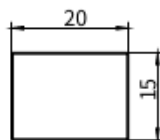

SIL-20G

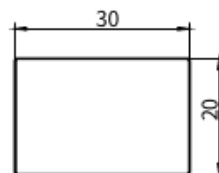

SIL-30G

货号(PN)	4.Y00486	4.Y00485	4.Y00514
型号(Model)	SIL-14G	SIL-20G	SIL-30G
适用产品(Applicable Products)	GFR14-95G	GFR20-95EG GFR20-95LG GFR20-95SG	GFR30-95G
温度范围(Temperature range)	-40°-200°	-40°-200°	-40°-200°

货号 PN	型号 Model	材料 Materials	颜色 Color	温度范围 Temperature range
4.Y00486-HNBR	SIL-14G-HNBR	HNBR		-40°-150°
4.Y00485-HNBR	SIL-20G-HNBR			
4.Y00514-HNBR	SIL-30G-HNBR			
4.Y00486-NBR	SIL-14G-NBR	NBR		-40°-120°
4.Y00485-NBR	SIL-20G-NBR			
4.Y00514-NBR	SIL-30G-NBR			
4.Y00486-TPU	SIL-14G-TPU	TPU		-60°-100°
4.Y00485-TPU	SIL-20G-TPU			
4.Y00514-TPU	SIL-30G-TPU			
4.Y00486-EPDM	SIL-14G-EPDM	EPDM		-60°-150°
4.Y00485-EPDM	SIL-20G-EPDM			
4.Y00514-EPDM	SIL-30G-EPDM			

## 拨指选件

### Finger Grippers Options

#### 夹具拴

#### Clamp bolts



1. 通过真空检测来判断拨指是否夹住物品。
2. 轻量化设计。
3. 上下行程可调。

1. Use a vacuum test to determine if the finger is holding the object.
2. Lightweight design.
3. Up and down stroke adjustable.

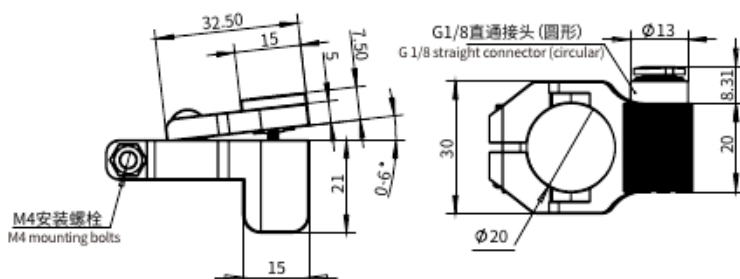

货号 PN	型号 Model	检测方式 Detection method	工作温度 Operating temperature	开合角度 Opening and closing angle	重量 Weight
7.Y02104	GP3-20V	真空检测 Vacuum detection	-40~70°C	0~6°	25.2g



1. 通过磁性传感器来判断拨指是否夹住物品。
2. 轻量化设计。
3. 上下行程可调。

1. A magnetic sensor is used to determine whether a finger is holding an object.
2. Lightweight design.
3. Up and down stroke adjustable.

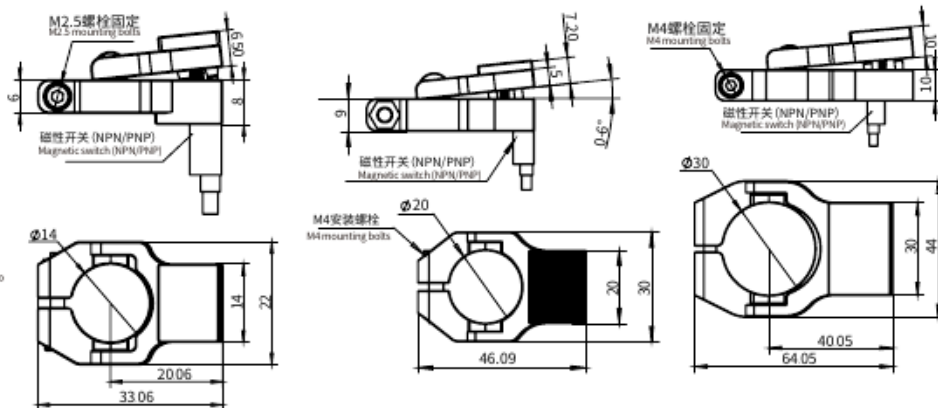

GP3-14

GP3-20

GP3-30

货号 PN	型号 Model	检测方式 Detection method	工作温度 Operating temperature	开合角度 Opening and closing angle	重量 Weight
7.Y02266	GP3-14P	磁感检测 Magnetic induction testing	-40~70°C	0~6°	11g
7.Y02267	GP3-14N				11g
7.Y02102	GP3-20P				20.4g
7.Y02103	GP3-20N				20.4g
7.Y02269	GP3-30P				32g
7.Y02268	GP3-30N				32g



# 拨指选件

## Finger Grippers Options

### 夹具栓

#### Clamp bolts

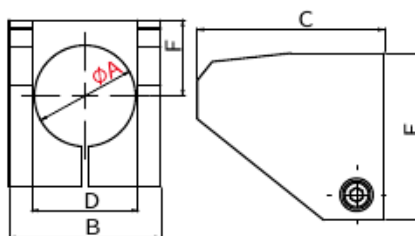

货号(PN)	型号(Model)	A(mm)	B(mm)	C(mm)	D(mm)	E(mm)	F(mm)	重量(Weight)
7.Y00778	GP1-20	Ø20	30	37	21	33	15	20g
7.Y00779	GP1-30	Ø30	45	65	32	44	20	60g

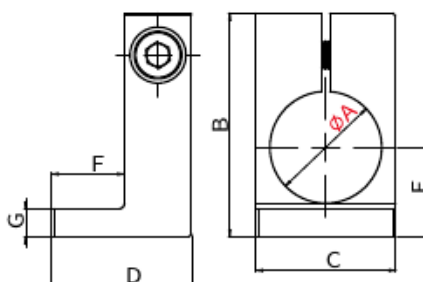

货号(PN)	型号(Model)	A(mm)	B(mm)	C(mm)	D(mm)	E(mm)	F(mm)	G(mm)	重量(Weight)
7.Y00780	GP2-14	Ø14	24	19	12	11	6	3.5	5g
7.Y00781	GP2-20	Ø20	35	25	25	16	13	5	14g
7.Y00782	GP2-30	Ø30	45	35	25	21	13	5.5	23g

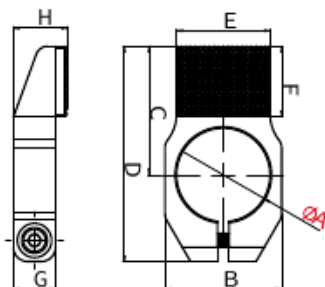

GP3-20L

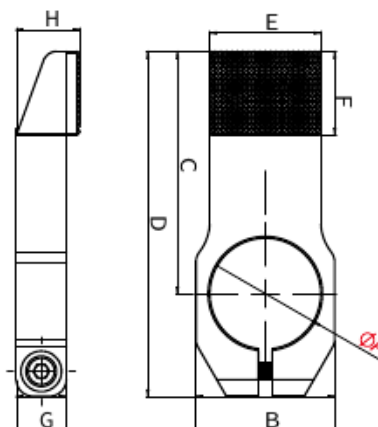

货号(PN)	型号(Model)	A(mm)	B(mm)	C(mm)	D(mm)	E(mm)	F(mm)	H(mm)	G(mm)	重量(Weight)
7.Y00783	GP3-14	Ø14	19	19	32	14	11	8.5	6	6g
7.Y00700	GP3-20	Ø20	25	27.5	46	20	15	11.5	9	12g
7.Y00908	GP3-20L	Ø20	25	50	68.5	20	15	11.5	9	19.8g
7.Y00785	GP3-30	Ø30	37	40	63	30	20	14.1	10	30g

Profile, SUS Tube  
型材、钢管

Stents Module  
支架模组

Quick Changer  
快换

Grip Module  
夹具组件

Air Nipper  
气动剪刀

Vacuum Module  
真空组件

Accessory Components  
附件

## 拨指选件

### Finger Grippers Options

#### 夹具栓

#### Clamp bolts

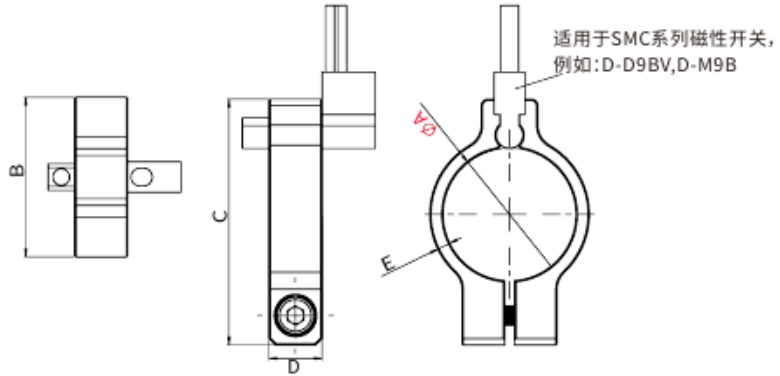

货号(PN)	型号(Model)	A(mm)	B(mm)	C(mm)	D(mm)	E(mm)	重量(Weight)
7.Y00786	GS-14	Ø14	18	30	8	2	14g
7.Y00787	GS-20	Ø20	24	37	8	2	17g
7.Y00788	GS-30	Ø30	34	47	8	2	25g



Profile- SUS Tube  
型材、钢管

Stents Module  
支架模组

Quick Changer  
快换

Grip Module  
夹具组件

Air Nipper  
气动剪刀

Vacuum Module  
真空组件

Accessory Components  
附件

# 单动拨指(GO系列)

## One Finger Angular Pneumatic Grippers (Series GO)

Profile、SUS Tube  
型材、钢管

Stents Module  
支架模组

Quick Changer  
快换

Grip Module  
夹具组件

Air Nipper  
气动剪刀

Vacuum Module  
真空组件

Accessory Components  
附件



GOF20-20-VMQ



GOF20-20-NBR

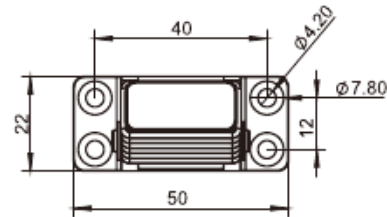
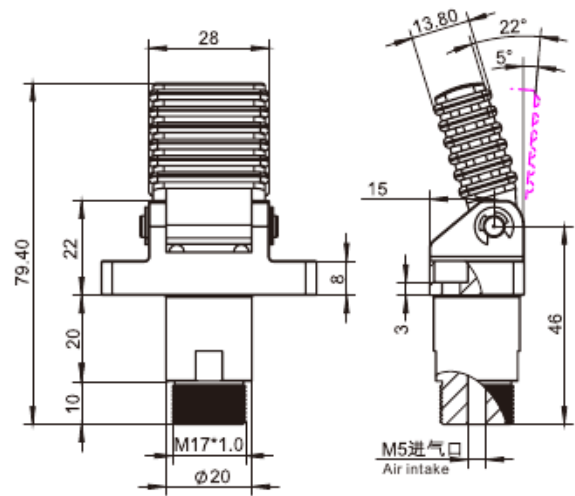

货号(PN)	型号(Model)	耐高温Heat resistance (in °C)	重量(Weight)
8.Y00396	GOF20-20-NBR	-20 to 80	57.4g
8.Y00395	GOF20-20-VMQ	-40 to 160	57.4g



GOP20-20-VMQ



GOP20-20-NBR

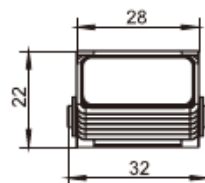
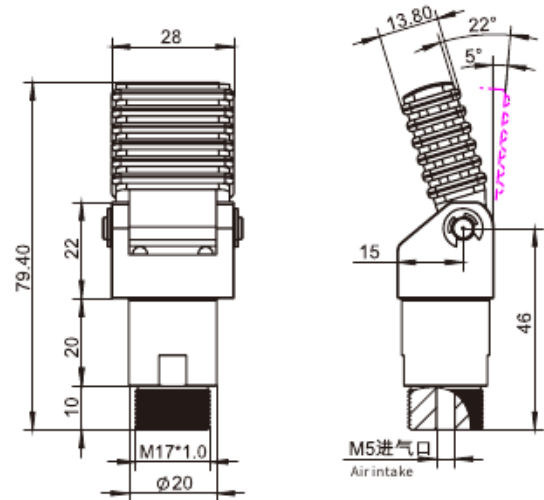

货号(PN)	型号(Model)	耐高温Heat resistance (in °C)	重量(Weight)
8.Y00398	GOP20-20-NBR	-20 to 80	50g
8.Y00397	GOP20-20-VMQ	-40 to 160	50g

## 可选的磁传感器

### Optional Magnetic Sensors

磁性传感器(可选)通过活塞上的一个磁铁检测出操作位置。因此,使用磁传感器是为了避免大量的磁性材料和强烈的磁场可能会造成传感问题。

可用的传感器:

The operating position is detected by magnetic proximity sensors (optional) through a magnet placed on the piston.

The use of magnetic proximity sensors is to be avoided in the vicinity of large masses of ferromagnetic material or intense magnetic fields as this may cause detection problems.

The sensors that can be used are:



D-M9PV



D-M9B



货号(PN)	1.Y00293
型号(Model)	D-MQ

D-M9N·M9NV

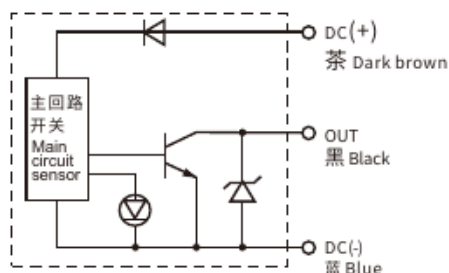

D-M9P·M9PV

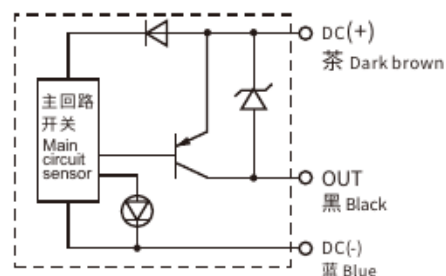

D-M9B·M9BV

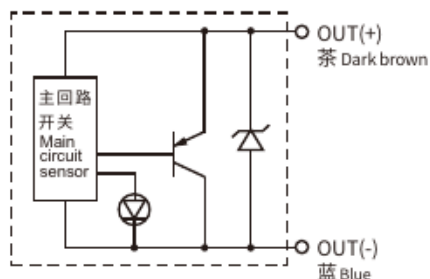

货号(PN)	型号(Model)	开关类型	L(mm)
1.Y00310	D-M9B	2PIN	电缆 cable 0.5m
1.Y00307	D-M9BL		电缆 cable 3.0m
1.Y02565	D-M9BV	2PIN	电缆 cable 0.5m
1.Y03843	D-M9BVL		电缆 cable 3.0m
1.Y00311	D-M9N	NPN	电缆 cable 0.5m
1.Y00295	D-M9NL		电缆 cable 3.0m
1.Y00298	D-M9NV	NPN	电缆 cable 0.5m
1.Y03598	D-M9NVL		电缆 cable 3.0m
1.Y00309	D-M9P	PNP	电缆 cable 0.5m
1.Y02301	D-M9PL		电缆 cable 3.0m
1.Y00296	D-M9PV	PNP	电缆 cable 0.5m
1.Y02964	D-M9PVL		电缆 cable 3.0m

# 姿势组配件

## Pneumatic Tilt Units

Profile、SUS Tube  
型材、钢管

Stents Module  
支架模组

Quick Changer  
快换

Grip Module  
夹具组件

Air Nipper  
气动剪刀

Vacuum Module  
真空组件

Accessory Components  
附件



- 90° 旋转。
- 双作用型，单一动作。
- 通过压缩空气和弹簧复位起重。
- 多个安装附件。
- 可选的磁传感器。
- 90° rotation.
- Double-acting, single-acting.
- Lifting by compressed air, spring reset.
- Several mounting accessories.
- Optional magnetic sensors.

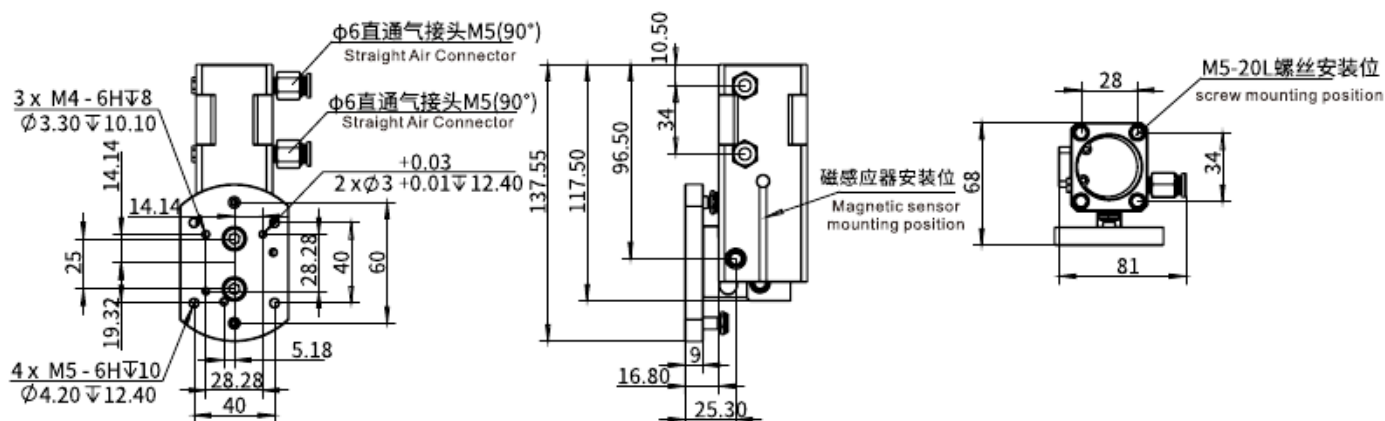

货号(PN)	8.Y01222
型号(Model)	GFT30-90
介质 Medium	已过滤, 润滑型/未润滑型压缩空气 Filtered, lubricated/non lubricated compressed air
压力范围 Pressure range	2~8bar
解锁范围 Unlock pressure	-
温度范围 Temperature range	5~60°C.
倾斜角度 Tilt angle	90°
末端行程调节 End stroke adjustment	±2°
循环空气消耗量 Cycle air consumption	55cm <sup>3</sup>
6 bar压力下的起重扭矩(90°→0°) Lift torque at 6 bar(90°→0°)(Mu)	>9 Nm
6 bar压力下的降落扭矩(0°→90°) Drop torque at 6 bar(0°→90°)(Md)	>4 Nm
允许的负载 Allowed load(F)	50 N
允许的力矩 Allowed moment(Mf)	3 Nm
重量 Weight	549g

# 姿势组配件 NEW

## Pneumatic Tilt Units



- 90° 旋转。
  - 双作用型，单一动作。
  - 通过压缩空气和弹簧复位起重。
  - 多个安装附件。
  - 可选的磁传感器。
- 90° rotation.
  - Double-acting, single-acting.
  - Lifting by compressed air, spring reset.
  - Several mounting accessories.
  - Optional magnetic sensors.

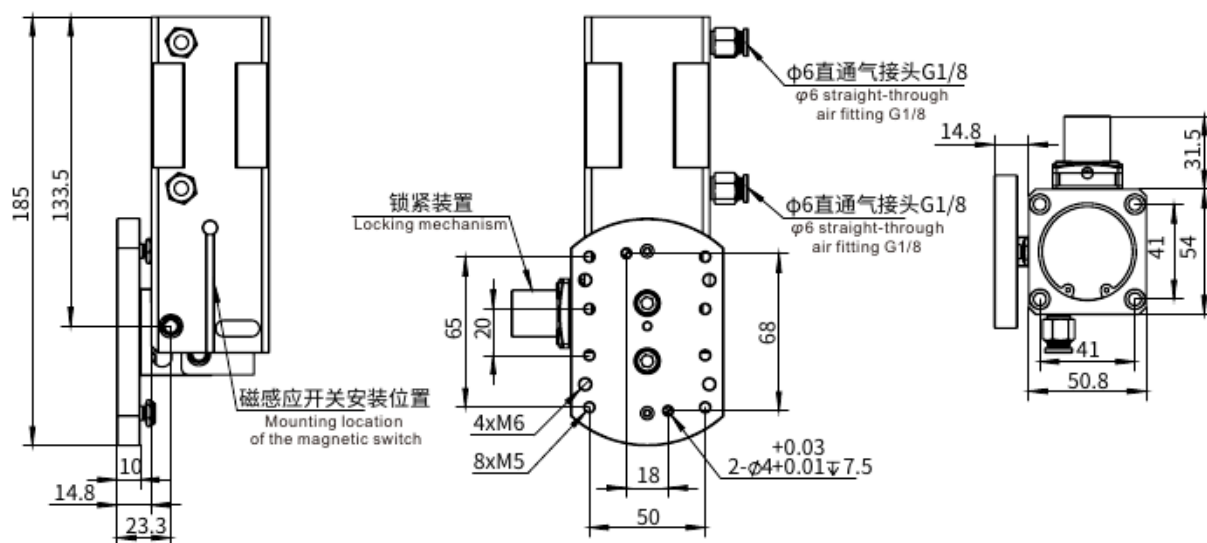

货号(PN)	8.Y01223
型号(Model)	GFT40-90
介质 Medium	已过滤, 润滑型/未润滑型压缩空气 Filtered, lubricated/non lubricated compressed air
压力范围 Pressure range	2~8bar
解锁范围 Unlock pressure	>3.5 bar
温度范围 Temperature range	5~60°C.
倾斜角度 Tilt angle	90°
末端行程调节 End stroke adjustment	±2°
循环空气消耗量 Cycle air consumption	140cm <sup>3</sup>
6 bar压力下的起重扭矩(90°→0°) Lift torque at 6 bar(90°→0°)(Mu)	>23 Nm
6 bar压力下的降落扭矩(0°→90°) Drop torque at 6 bar(0°→90°)(Md)	>10 Nm
允许的负载 Allowed load(F)	100 N
允许的力矩 Allowed moment(Mf)	7 Nm
重量 Weight	1053g

型材、钢管  
Profile、SUS Tube

支架模组  
Stents Module

快换  
Quick Changer

夹具组件  
Grip Module

气动剪刀  
Air Nipper

真空组件  
Vacuum Module

附件  
Accessory Components

# 姿势组配件 NEW

## Pneumatic Tilt Units

Profile、SUS Tube  
型材、钢管

Stents Module  
支架模组

Quick Changer  
快换

Grip Module  
夹具组件

Air Nipper  
气动剪刀

Vacuum Module  
真空组件

Accessory Components  
附件



- 90° 旋转。
- 双作用型，单一动作。
- 通过压缩空气和弹簧复位起重。
- 多个安装附件。
- 可选的磁传感器。
- 90° rotation.
- Double-acting, single-acting.
- Lifting by compressed air, spring reset.
- Several mounting accessories.
- Optional magnetic sensors.

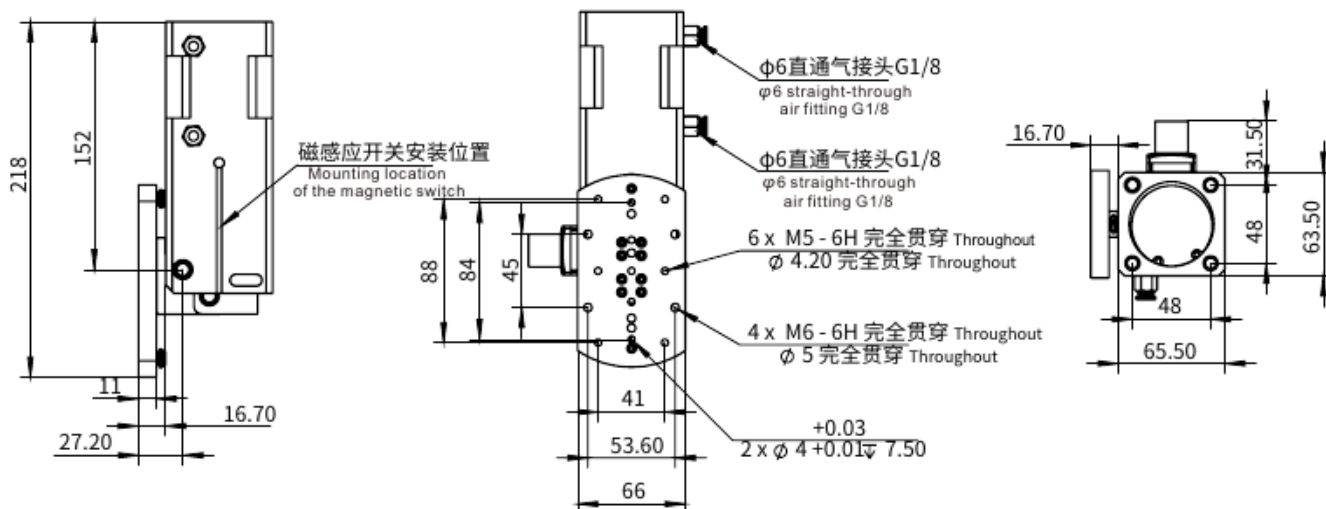

货号(PN)	8.Y01130
型号(Model)	GFT50-90
介质 Medium	已过滤, 润滑型/未润滑型压缩空气 Filtered, lubricated/non lubricated compressed air
压力范围 Pressure range	2~8bar
解锁范围 Unlock pressure	>3.5 bar
温度范围 Temperature range	5~60°C.
倾斜角度 Tilt angle	90°
末端行程调节 End stroke adjustment	±2°
循环空气消耗量 Cycle air consumption	263cm <sup>3</sup>
6 bar压力下的起重扭矩(90°→0°) Lift torque at 6 bar(90°→0°)(Mu)	>44 Nm
6 bar压力下的降落扭矩(0°→90°) Drop torque at 6 bar(0°→90°)(Md)	>22 Nm
允许的负载 Allowed load(F)	100 N
允许的力矩 Allowed moment(Mf)	7 Nm
重量 Weight	1884g

# 姿势组配件

## Pneumatic Tilt Units



- 90° 旋转。
- 双作用型, 单一动作。
- 通过压缩空气和弹簧复位起重。
- 多个安装附件。
- 可选的磁传感器。
- 90° rotation.
- Double-acting, single-acting.
- Lifting by compressed air, spring reset.
- Several mounting accessories.
- Optional magnetic sensors.

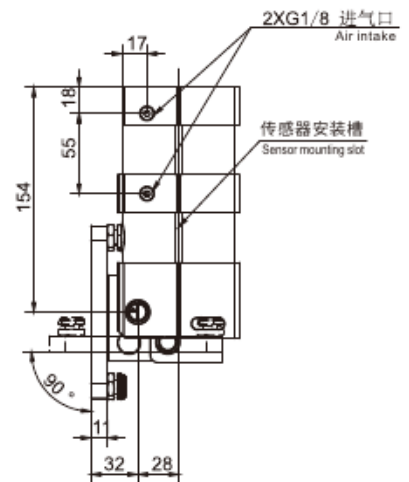
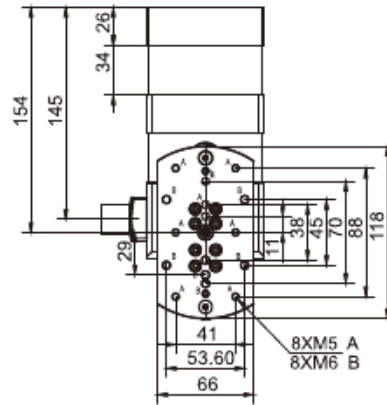
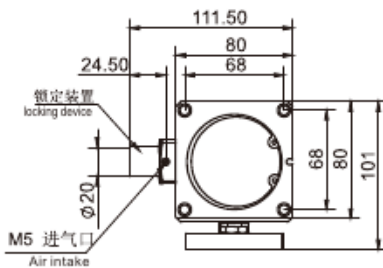

货号(PN)	8.Y01007
型号(Model)	GFT60-90
介质 Medium	已过滤, 润滑型 / 未润滑型压缩空气 Filtered, lubricated / non lubricated compressed air
压力范围 Pressure range	2 ~ 8 bar
解锁范围 Unlock pressure	> 3.5 bar
温度范围 Temperature range	5 ~ 60 °C.
倾斜角度 Tilt angle	90°
末端行程调节 End stroke adjustment	± 2°
循环空气消耗量 Cycle air consumption	462 cm <sup>3</sup>
6 bar 压力下的起重扭矩(90° → 0°) Lift torque at 6 bar (90° → 0°) (Mu)	> 78 Nm
6 bar 压力下的降落扭矩(0° → 90°) Drop torque at 6 bar (0° → 90°) (Md)	> 42 Nm
允许的负载 Allowed load (F)	300 N
允许的力矩 Allowed moment (Mf)	30 Nm
重量 Weight	2576g

Profile-  
SUSTube  
型材、钢管

Stents Module  
支架模组

Quick Changer  
快换

Grip Module  
夹具组件

Air Nipper  
气动剪刀

Vacuum Module  
真空组件

Accessory Components  
附件

# 姿势组配件 NEW

## Pneumatic Tilt Units

Profile, SUS Tube  
型材、钢管

Stents Module  
支架模组

Quick Changer  
快换

Grip Module  
夹具组件

Air Nipper  
气动剪刀

Vacuum Module  
真空组件

Accessory Components  
附件



- 90° 旋转。
- 双作用型, 单一动作。
- 通过压缩空气和弹簧复位起重。
- 多个安装附件。
- 可选的磁传感器。
- 90° rotation.
- Double-acting, single-acting.
- Lifting by compressed air, spring reset.
- Several mounting accessories.
- Optional magnetic sensors.

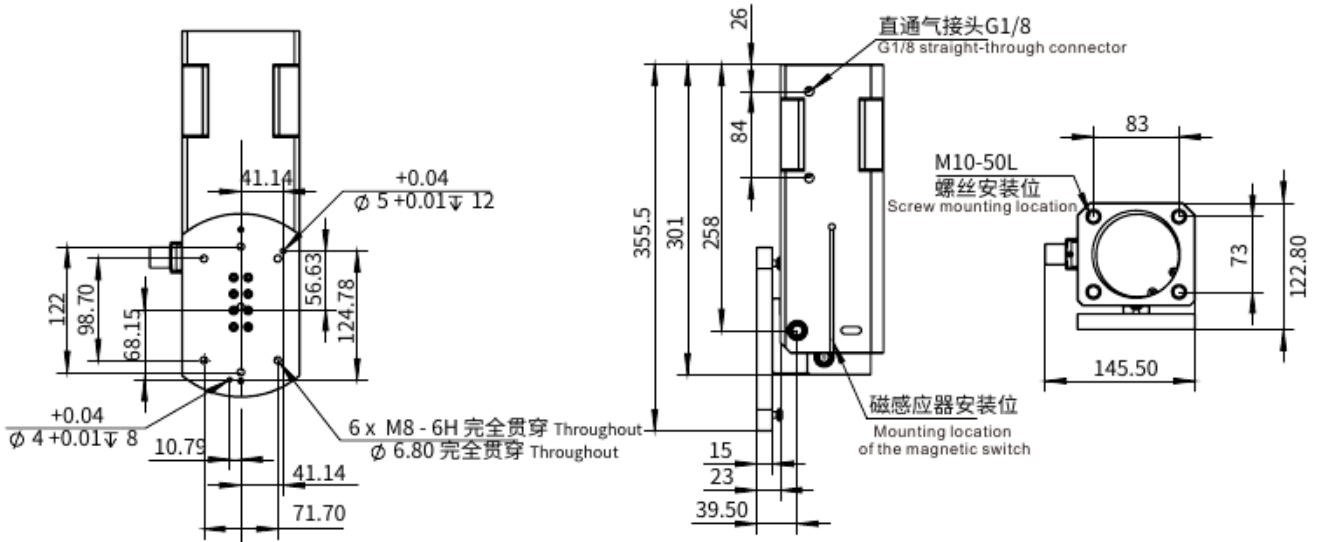

货号(PN)	8.Y01390
型号(Model)	GFT80-90
介质 Medium	已过滤, 润滑型 / 未润滑型压缩空气 Filtered, lubricated / non lubricated compressed air
压力范围 Pressure range	2 ~ 8 bar
解锁范围 Unlock pressure	> 3.5 bar
温度范围 Temperature range	5 ~ 60 °C.
倾斜角度 Tilt angle	90°
末端行程调节 End stroke adjustment	± 2°
循环空气消耗量 Cycle air consumption	985 cm <sup>3</sup>
6 bar 压力下的起重扭矩(90° → 0°) Lift torque at 6 bar (90° → 0°)(Mu)	> 175 Nm
6 bar 压力下的降落扭矩(0° → 90°) Drop torque at 6 bar (0° → 90°)(Md)	> 85 Nm
允许的负载 Allowed load(F)	600 N
允许的力矩 Allowed moment(Mf)	75 Nm
重量 Weight	7950g

# Min 姿势夹具

## Min Posture Gripper



- 90° 旋转。
- 双作用型, 单一动作。
- 通过压缩空气和弹簧复位起重。
- 多个安装附件。
- 可选的磁传感器。
- 90° rotation.
- Double-acting, single-acting.
- Lifting by compressed air, spring reset.
- Several mounting accessories.
- Optional magnetic sensors.

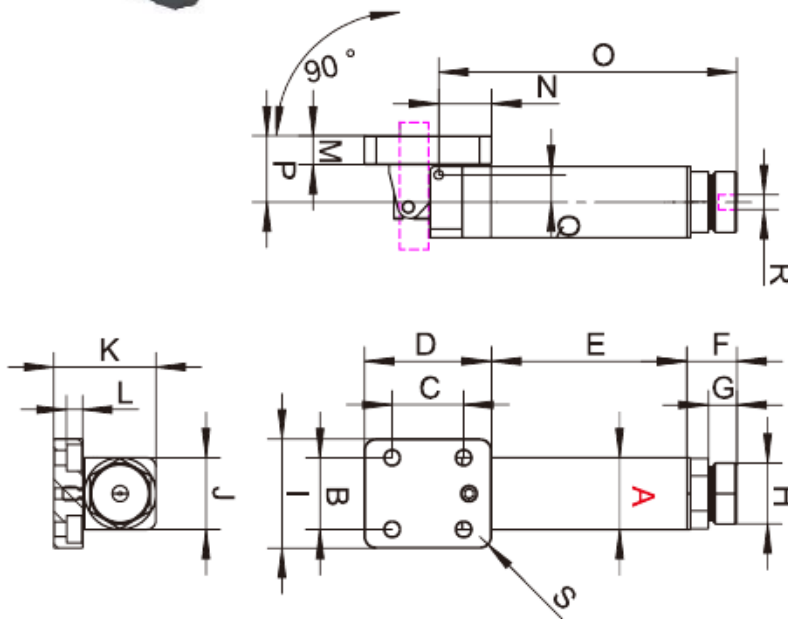

货号 PN	型号 Model	介质 Medium	压力范围 Pressure range	温度范围 Temperature range	倾斜角度 Tilt angle	6 bar压力下的起重扭矩 Lift torque at 6 bar	重量 Weight
8.Y00094	GFN20-90	已过滤, 润滑型 未润滑型压缩空气 Filtered, lubricated non lubricated compressed air	2 ~ 8 bar	-10 ~ 70 °C	90°	120 Ncm	65g
8.Y00116	GFN30-90					300 Ncm	210g

货号 PN	型号 Model	A	B	C	D	E	F	G	H	I	J	K	L	M	N	O	P	Q	R	S
8.Y00094	GFN20-90	Ø20	20	20	35.5	54.6	14	8	17	30.5	20	28.5	4.5	8	14.74	83.34	18.5	7.6	M5	3.25
8.Y00116	GFN30-90	Ø30	25	25	46	81.5	19	11	M27*1	37	30	40	5.5	10	18.5	119	25	11	G1/8	3

型材、钢管  
Profile, SUS Tube

支架模组  
Stents Module

快换  
Quick Changer

夹具组件  
Grip Module

气动夹刀  
Air Nipper

真空组件  
Vacuum Module

附件  
Accessory Components

# 无纺布埋入气缸

## Non-woven Fabric Embedded Cylinder

Profile, SUS Tube  
型材、钢管

Stents Module  
支架模组

Quick Changer  
快换

Grip Module  
夹具组件

Air Nipper  
气动剪刀

Vacuum Module  
真空组件

Accessory Components  
附件



- 无纺布埋入气缸。
- 通过压缩空气推出收回。
- 50mm超长推出行程。
- 高强度中心轴体。
- Nonwoven fabric embedded in cylinder.
- Push-out retraction by compressed air.
- 50mm long push-out stroke.
- High strength centre shaft.

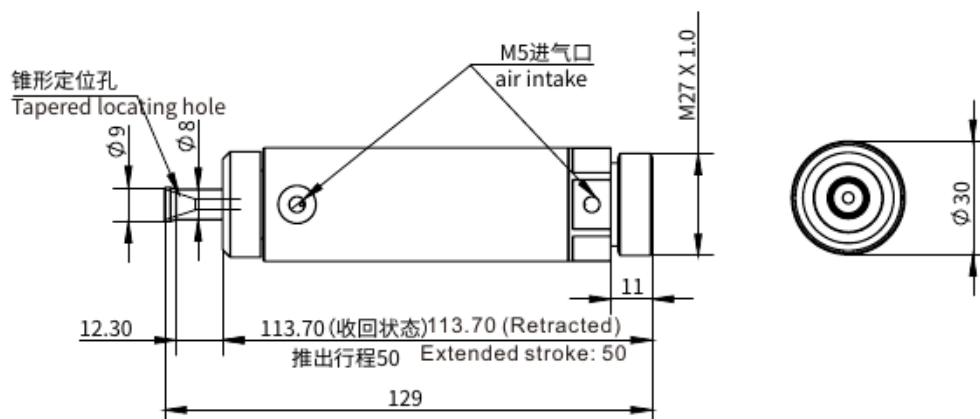

货号 PN	型号 Model	介质 Medium	压力范围 Pressure range	温度范围 Temperature range	行程 Stroke	内置磁环 Built-in magnetic ring	重量 Weight
8.Y01398	GNS-3050-S1	已过滤, 润滑型 未润滑型压缩空气 Filtered, lubricated non lubricated compressed air	2.5 ~ 8bar	-10 ~ 70 °C	50	x	261g

# 气动磁性夹具

## Pneumatic Magnetic Fixture



- 双动式气动活塞
  - 磁场集中在夹持点
  - 可选磁性传感器
  - 食品级润滑脂
  - 即使没有气动电源, 也能夹持工作
  - 适合搬运小型铁磁部件和磁铁
- Double-acting pneumatic piston
  - Magnetic field concentrated at the clamping point
  - Optional magnetic sensor
  - Food grade grease
  - Clamping work even without pneumatic power supply
  - Ideal for handling small ferromagnetic parts and magnets

用途: 用于夹持带磁性的产品, 可多个搭配一起使用

Use: for clamping magnetic products, can be used together with multiple ones

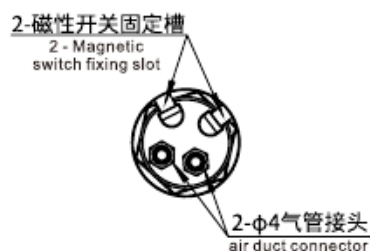
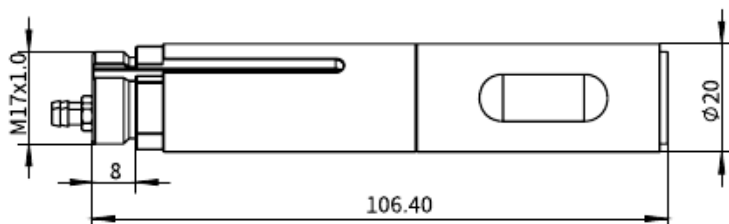

货号(PN)	8.Y01088
型号(Model)	GMAG-20
介质 Medium	已过滤, 润滑型 未润滑型压缩空气 Filtered, lubricated non lubricated compressed air
压力范围 Pressure range	2~8bar
温度范围 Temperature range	5 ~ 60 °C
活塞行程 Piston stroke	23mm
活塞直径 Piston diameter	φ16mm
磁场强度 Magnetic strength	7N
最大工作频率 Maximum working frequency	1.5Hz
循环空气消耗量 Cycle air consumption	11m <sup>3</sup>
重量 Weight	69g

Profile- SUS Tube  
型材、钢管

Stents Module  
支架模组

Quick Changer  
快换

Grip Module  
夹具组件

Air Nipper  
气动剪刀

Vacuum Module  
真空组件

Accessory Components  
附件

塑料浇口用气动剪刀

## Air Nippers For Resin Gate

这些都是专业的气动剪刀，可安装在精确的浇口切割设备和备用夹具上。VESSEL可提供丰富的选择，以满足各种需求。

These are high-class air nippers that can be mounted on gate cutting equipment and standby jigs for accurate, speedy cutting of resin products. VESSEL has a wide selection of items to meet a variety of needs from around-the-clock operations to high cutting precision.



# Solution

切断, 抓取, 卷曲和打孔  
Cut, grab, crimp and punch.

## 剪切直浇口树脂产品

Cutting direct gate molded components

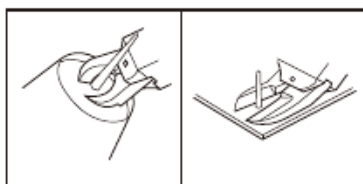

切割服装盒、头盔、管接头部件、垃圾桶、花盆等大口径的浇口。超长的使用寿命。

Cuts large diameter sprues such as garment cases, helmets, pipe joint parts, trash cans, planters. Superb durability in long term use.

## 剪切多模成型树脂产品

Gate cut for multiple impression molded components

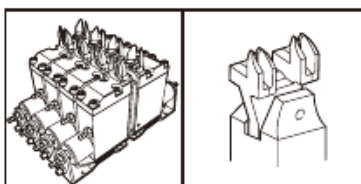

结构紧凑、轻便, 带有报警装置, 易于安装在卡盘和待机夹具上。能有效的削减匹配周期时间。

Compact, lightweight body and with a large selection of blade items, easy mounting on chuck board and standby jig. Achieves efficient cuts matching cycle time.

## 剪切珠宝饰品

Taking products from a jewelry tree



切割戒指、项链等贵金属。超强的耐用性和强大的刀头大大的提高了效率。

Cutting of precious metals for rings, necklaces etc. Superb durability and increased efficiency with powerful nipper blades.

## 剪切透镜, 导光板等透明产品

Gate cutting for lenses, LGP, and transparent products

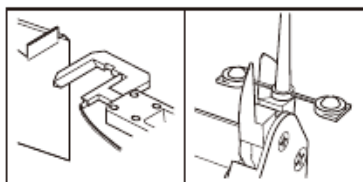

防止剪切浇口纹裂, 卷边, 白化, 采用加热型气动剪刀进行剪切。刀头温度与剪切速度相互配合, 达到高精度剪切效果。

Various heated nippers prevent cracks and whitening, the decisive factor is the heating temperature of the blades and cutting speed. Supports demands for improved flexibility and high precision cutting.

## 剪切药筒, 食品盒等产品

Pre-form cutting for food and drug cases

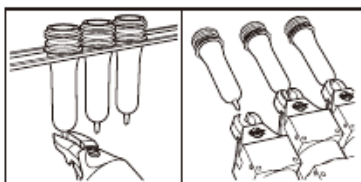

广泛安装于预成型机, 提高生产效率和剪切精度, 提升产品质量。

Improved efficiency in pre-forming, nippers attached to flat finish pre-form molding machine. Cut precision is linked to product quality.

## 剪切电子元件和电路板

Cutting electronic components and around boards

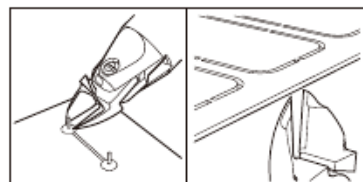

最适于手动剪切焊接后的电路引线, 大幅降低手腕疲劳。电路板安装于台式机器人上进行剪切。

Optimal handy nippers for cutting lead lines after soldering to significantly reduce wrist strain. Substrate is attached to the desktop robot...

型材、钢管  
Profile, SUStube

支架模组  
Stents Module

快换  
Quick Changer

夹具组件  
Grip Module

气动剪刀  
Air Nipper

真空组件  
Vacuum Module

附件  
Accessory Components

剪断卷线机绕线

## Wire cutting with coil winding machine

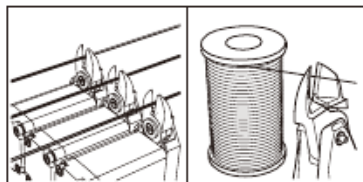

气动剪刀安装于卷线机绕线切断单元上，剪断不能撕开的粗线。

Attach to the nipper unit of automatic coil winding machine for power transformers, fan motors and ignition. Cutting thick diameter wires that cannot be torn off.

回收厂拆除用的手动工具

## Hand tools for dismantling in recycling plants

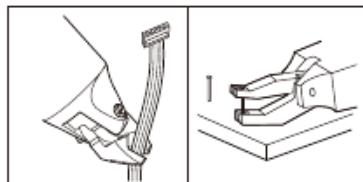

在个人电脑和办公自动化设备、弹球机、电视机、冰箱和洗衣机等回收工厂中切割各种电线，铜管和钢带等。钳可用于拔除弹球游戏机的销目。

Cuts a variety of wires, copper tubing and steel bands in recycling plants such as PCs and OA equipment, pachinko machines, TVs, and refrigerators, washing machines, etc. Nippers for the purpose of pulling out the pachinko machine pins.

用于端子的铆接，压边

## Crimping task for solderless terminals

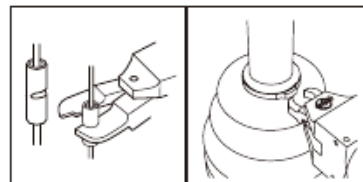

用于配电板，电子产品，照明设备等各种电路连接线的端子压边。降低手指和手腕疲劳。

For crimping terminals with various wiring harnesses such as for switchboards, electrical products and lighting equipment. Less strain on fingers and wrists. Increased work efficiency for stop rings for auto parts.

用于铝制品或树脂部材的开孔

## Die cutter for aluminum products and plastic components

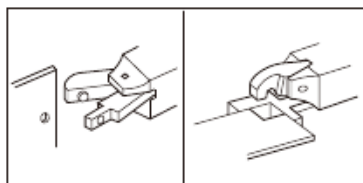

特殊定做刀头，可应用于铝制窗框或薄板的开孔。

By support for separate blades, allows punching and form cutting of aluminum sash and thin plates.

用于吹塑成型产品的开孔，冲孔

## Punching of blow molded products, punching slotted holes

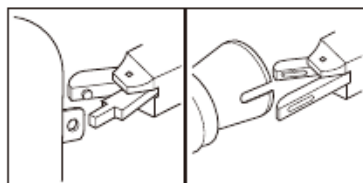

应用于生产工序中无法进行开孔，冲孔工序的容器，管路等产品。

Punching blow molded products, punching slotted holes, for containers that cannot be punched and automobile ducts, etc.

其他应用

## Other applications

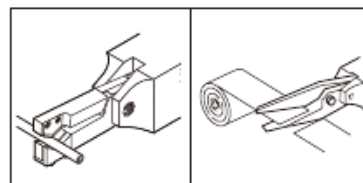

微刃气剪，可以切割各种难切割的纤维，碳纤维，芳纶纤维和软塑料板。用于切割牛仔裤，回收高尔夫球，纺织机械边缘切割的刀头等。

Micro-edge air scissors that can cut various hard-to-cut fibers, carbon, aramid fibers, and soft plastic sheets. Nippers for cutting belt loops of jeans, peeling recycled golf balls, cutting edges with textile machinery, etc.

# 气动剪刀选择方法

## Selection Method For Air Nipper

### 材质确认

Check materials

需要剪切产品的材质?

- 金属丝
  - 钢丝
  - 铜丝
  - 钢琴线 (未经热处理/ HV320或以下)、贵金属等
- 树脂成型品
  - 软塑料 (聚氯乙烯, 聚乙烯)
  - 硬塑料 (丙烯酸, 聚碳酸酯, ABS等)
- 其他应用
  - 确认材质, 实际应用和操作内容 (弯曲、铆合、冲孔、自动剪切, 手动剪切等)

What is the "cutting target (workpiece)"?

- Metal wire
  - Steel wire
  - Copper wire
  - Piano wire (not heat processed/HV320 or below), precious metals etc.
- Molded plastic
  - Soft plastic (PP PE PS PVC PMMA AS etc.)
  - Hard plastic (PPS PA PBT LCP ABS POM PC GF etc.)
- Other applications
  - Check materials, applications and work. (Bending, caulking, punching, robotic hand, and scissors.)

### 尺寸检查

Check dimensions

切割部件的尺寸有多大? How big is the "size of the cut portion"?

- 金属
  - 角度 (mmxmm) [根据截面积选择型号]
  - 圆形 (Φmm)
- 塑料
  - 角度 (mmxmm) [根据截面积选择型号]
- 其他应用
  - 确认材质, 实际应用和操作内容。
- Metal
  - Angle (mm × mm) [select model by cross-section area]
  - Round (Φ mm)
- Plastic
  - Angle (mm × mm) [select model by cross-section area]
- Other applications
  - Check materials, applications and work.

### 使用

Usage

"工作的状态/环境" 是怎样的?

What is the "state/environment of the work"?

- 用于自动化剪切
- 用于手动剪切
- 安装在夹具上使用, 等等
- Used mounted on automated machinery and robots.
- Used for manual work.
- Used mounted on a jig. And so forth

### 型号选择

Select model

选择合适的型号。

Choose a model suitable for the purpose.

请按照[使用方式和剪切尺寸]选取气动剪刀本体, 按照[剪切材质, 尺寸, 形状等]选取刀头。

刀本体和刀头的特点, 用途等, 请参考各自的[产品规格],

另外本体选取时请参考[性能选择指南]

根据剪切产品形状, 材质的不同, 标准品可能无法对应。

Choose based on "usage and cut dimensions" for the main unit, and "material and dimensions/shape" for the blades.

Refer to "product specifications" for the main unit/blade characteristics/usage, respectively. Also when selecting the machine, refer to "capability selection chart".

The shape/material of the workpiece may not be compatible with standard products.

型材、钢管  
Profile, SUS Tube

支架模组  
Stents Module

快换  
Quick Changer

夹具组件  
Grip Module

气动剪刀  
Air Nipper

真空组件  
Vacuum Module

附件  
Accessory Components

# 性能选择指南

## Capability Selection Chart

类型 Types	Cutting material 切割材质							适用机型 Application model	空气压力 Airpressure (MPa)
	铜丝 Copper wire	钢丝 无加热处理 Steel wire (non-heat treated)	钢琴丝 (硬度HRC20以上) PianoWire (HV 320 or below)	软塑料 Soft Plastic		硬塑料 Hard Plastic	端子压边 Solderless terminals		
				直径 (Diameter)	横截面 (Cross Section)				
N · NS · NR	1.0mm	0.5mm	0.2mm	2.0mm	3.1 mm			NS2,N3,NS3,NR3	0.4~0.5
	1.0	0.5	0.3	2.0	3.1			N5,NS5,NR5	0.4~0.5
	1.6	1.0	0.5	3.0	7.0	2.0mm		N7,NS7,NR7	0.4~0.5
	1.8	1.2	0.5	4.0	12.5	2.6		N10,NS10L,NR10L	0.4~0.5
	2.3	1.7	0.6	4.5	15.8	4.0		N12	0.4~0.5
	2.6	2.0	1.0	7.0	38.4	5.0		N20,NS20,NR2 0	0.5~0.6
	3.3	2.8	1.2	10.0	78.5	6.5	1.25/2.0	N30,NS30,NR3 0	0.5~0.6
	5.5	4.5	2.0	12.0	113.0	6.5		NS0,NR50	0.5~0.6
增压器 With pressure booster	2.6	1.6		5.0	19.6	4.0	12.5/2.0	P-10L	
	3.0	2.2		8.0	50.2	6.0	2.0/5.5	P-20	
	4.8	4.0		13.0	132.6	7.0	~0.8	P-30	
	6.5	5.5						P-50	
NY	1.6	1.0		2.0	3.1	1.3		NY03	0.4~0.5
				3.0	7.0	2.0		NF05,NY05	0.4~0.5
				3.5	9.6	2.3		NF10,NY10	0.4~0.5
				4.0	12.5	2.6		NF15,NY15	0.4~0.5
				5.0	19.6	3.4		NY25	0.5~0.6
NT				1.5	1.7	1.0		NT03	0.4~0.5
				2.5	4.9	1.5		NT05	0.4~0.5
				3.5	9.6	2.3		NT10	0.4~0.5
				5.0	19.6	3.4		NT20	0.4~0.5
	AS, HS, BJ type		BBB	AP, PF, AJ type			ACD type		

Profile, SUS Tube  
型材、钢管

Stents Module  
支架模组

Quick Changer  
快换

Grip Module  
夹具组件

Air Nipper  
气动剪刀

Vacuum Module  
真空组件

Accessory Components  
附件

# 滑动式气动剪刀NY系列 横向型

GT-NY05/10/15/25 Slide-Off Air Nippers Horizontal-Type

NY



横向滑动有助于空间有效利用。  
机身紧凑(高度低),不妨碍卡盘运行。

The horizontal slide enables space to be used effectively.  
The low profile of the main unit allows works to be removed without obstructing the operations of the chuck plate.

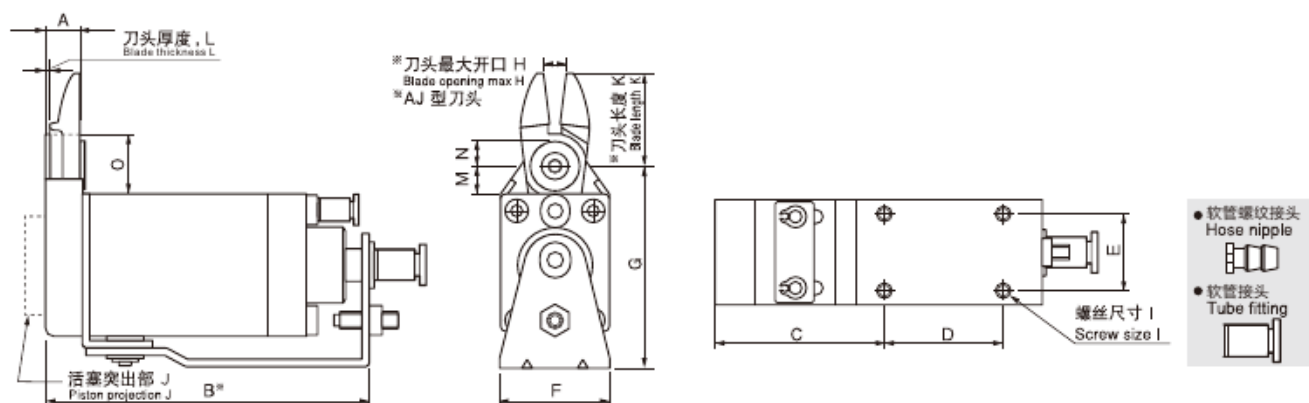

Capacity $\phi$ (mm)	Size (mm)															Air Consumption (cm <sup>3</sup> /s/r.)	Weight (g)	Slide Direction/ Stroke (mm)	Spec. & Size of the Hose Port				
	Soft Plastic	Hard Plastic	Copper	Steel	A	B	C	D	E	F	G	H	I	J	K					L	M	N	O
3.0	2.0	1.6	1.0	GT-NY05	8.6	75.9	40.9	25	15	23	47.6	4	M4	3	22	1.6	8.5	6.25	16.5	48	155	Pull 0~3	W/hose nipple
3.0	2.0	1.6	1.0	GT-NY05R																48	155	Push 0~3	Hose I.D. $\phi$ 2.5mm
3.0	2.0	1.6	1.0	GT-NY05-4																48	155	Pull 0~3	W/tube fitting
3.0	2.0	1.6	1.0	GT-NY05R-4																48	155	Push 0~3	Hose I.D. $\phi$ 2.5XO.D. $\phi$ 4mm
3.5	2.3			GT-NY10																68	210	Pull 0~3	W/hose nipple
3.5	2.3			GT-NY10R																68	210	Push 0~3	Hose I.D. $\phi$ 2.5mm
3.5	2.3			GT-NY10-4	8.8	82.1	42.1	30	20	28	51.6	6	M4	5	24	1.6	7.5	6.25	15.5	68	210	Pull 0~3	W/tube fitting
3.5	2.3			GT-NY10R-4																68	210	Push 0~3	Hose I.D. $\phi$ 2.5XO.D. $\phi$ 4mm
4.0	2.6			GT-NY15																136	319	Pull 0~3	W/hose nipple
4.0	2.6			GT-NY15R																136	319	Push 0~3	Hose I.D. $\phi$ 2.5mm
4.0	2.6			GT-NY15-4	10.2	93	48	35	25	33	58	8	M4	5	27	2	7.5	6.25	16.5	136	319	Pull 0~3	W/tube fitting
4.0	2.6			GT-NY15R-4																136	319	Push 0~3	Hose I.D. $\phi$ 2.5XO.D. $\phi$ 4mm
5.0	3.4			GT-NY25																184	580	Pull 0~5	W/hose nipple
5.0	3.4			GT-NY25R																184	580	Push 0~5	Hose I.D. $\phi$ 4mm
5.0	3.4			GT-NY25-6	12.5	108.5	54.5	40	30	42	69	9	M5	2	31	2.5	10.5	7	20.5	184	580	Pull 0~5	W/tube fitting
5.0	3.4			GT-NY25R-6																184	580	Push 0~5	Hose I.D. $\phi$ 4XO.D. $\phi$ 6mm

※Blade length(K) and opening max.(H) is the dimension adjusted for standard blade(AJ type). ※Air Pressure...0.4~0.5 MPa(NY25 type:0.5~0.6)  
※Refers to the distance from the cut position for PUSH style models,and the distance from the start position for PULL style models.

Profile- SUS Tube  
型材、钢管

Stents Module  
支架模组

Quick Changer  
快换

Grip Module  
夹具组件

Air Nipper  
气动剪刀

Vacuum Module  
真空组件

Accessory Components  
附件

# 滑动式气动剪刀NY系列 横向型

GT-NY03G/10G Slide-Off Air Nippers Horizontal-Type

# NY-G

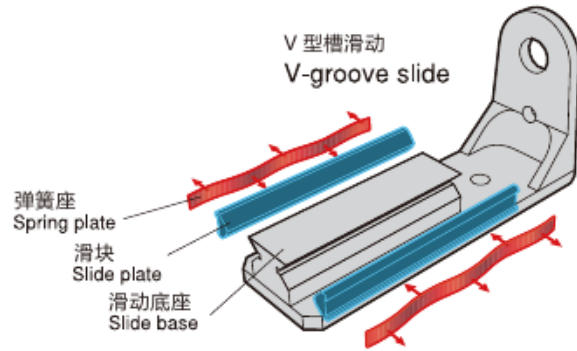

V型槽滑座确保定位稳定。

本体不承受倾斜负荷,实现高精度剪切。

VESSEL'S patented,v-groove slide base ensures constant, stable positioning.The unit is not subject to inclined loads, and has achieved high precision gate cutting performance.

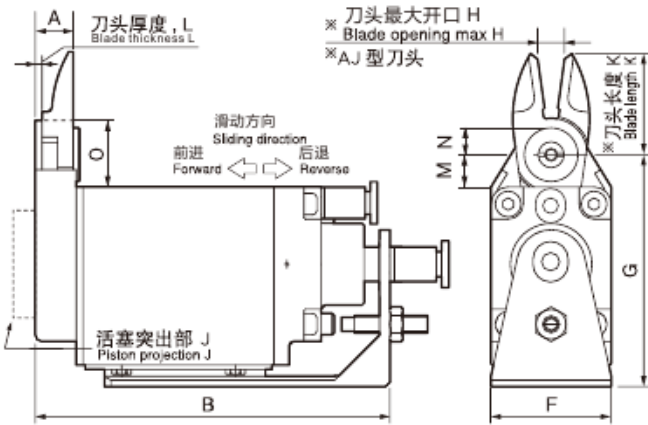

GT-NY03G

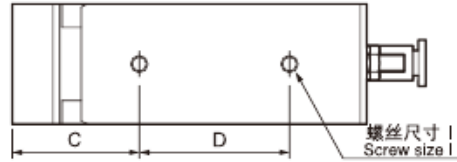

GT-NY10G

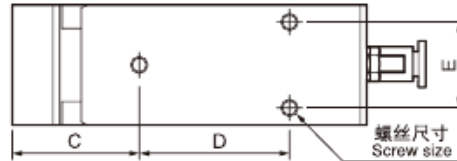

- 软管螺纹接头  
Hose nipple
- 软管接头  
Tube fitting

Capacity $\phi$ (mm) Soft Plastic Hard Plastic	Model No.	Size (mm)														Air Consumption (cm <sup>3</sup> /str.)	Weight (g)	Slide Travel/ Stroke (mm)	Spec. & Size of the Hose Port	
		A	B	C	D	E	F	G	H	I	J	K	L	M	N					O
2.0 1.3	GT-NY03G																37	160	Pull 0~3	W/hose nipple Hose I.D. $\phi$ 2.5mm
2.0 1.3	GT-NY03GR	8.6	74.5	29.5	30	-	19	46.5	3	M4	0	21	1.6	7.5	5.25	14.5	37	160	Push 0~3	
2.0 1.3	GT-NY03G-4																37	160	Pull 0~3	W/tube fitting Hose I.D. $\phi$ 2.5XO.D. $\phi$ 4mm
2.0 1.3	GT-NY03GR-4																37	160	Push 0~3	
3.5 2.3	GT-NY10G																68	275	Pull 0~3	W/hose nipple Hose I.D. $\phi$ 2.5mm
3.5 2.3	GT-NY10GR	8.8	82.6	29.6	35	20	28	54	6	M4	5	24	1.6	7.5	6.25	15.5	68	275	Push 0~3	
3.5 2.3	GT-NY10G-4																68	275	Pull 0~3	W/tube fitting Hose I.D. $\phi$ 2.5XO.D. $\phi$ 4mm
3.5 2.3	GT-NY10GR-4																68	275	Push 0~3	

\*Blade length(K) and opening max.(H) is the dimension adjusted for standard blade(AJ type). \*Air Pressure...0.4~0.5 Mpa  
Blade is optional.Note that forward and backward-facing blades are available

Profile, SUS Tube  
型材、钢管

Stentis Module  
支架模组

Quick Changer  
快换

Grip Module  
夹具组件

Air Nipper  
气动剪刀

Vacuum Module  
真空组件

Accessory Components  
附件

# 滑动式气动剪刀NY系列 横向复动式

GT-NY10S/25S Double Action Sliding Air Nippers

# NY-S

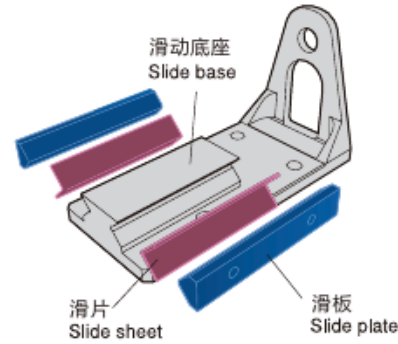

手动单元的无弹簧滑动结构提供平稳的运动。采用V型槽滑台进行高精度定位。

The springless slide construction of the main unit ensures smooth movement, and a v-groove slide base has been employed for high precision positioning.

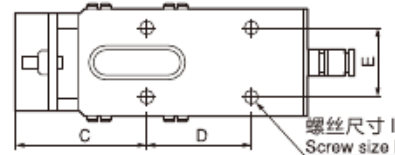
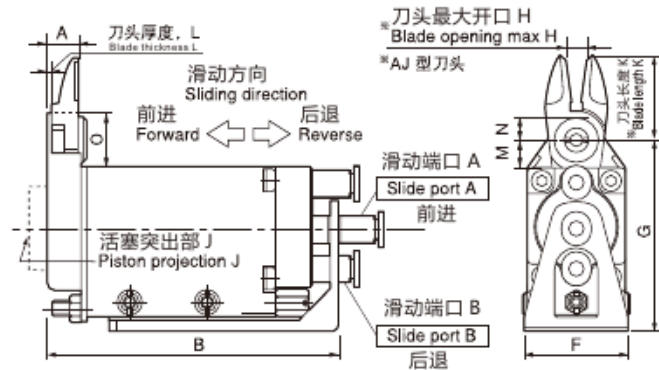

**WARNING**  
Injecting air into slide port A slides the nippers in reverse.  
Injecting air into slide port B slides the nippers forward.



Capacity $\phi$ (mm) Soft Plastic Hard Plastic	Model No.	Size (mm)														Air Consumption (cm <sup>3</sup> /str.)	Weight (g)	Slide Direction Distance (mm)	Spec. & Size of the Hose Port		
		A	B	C	D	E	F	G	H	I	J	K	L	M	N						O
3.5 2.3	GT-NY10S	8.8	84.5	38	30	20	32	55	6	M4	5	24	1.6	7.5	625	15.5	68	300	0~3.5	W/tube fitting	Hose I.D. $\phi$ 2.5XO.D. $\phi$ 4mm
5.0 3.4	GT-NY25S	12.5	106.5	47	40	30	47	72	9	M5	2	31	2.5	10.5	7	20.5	184	695	0~5.0	W/tube fitting	Hose I.D. $\phi$ 4XO.D. $\phi$ 6mm

※Blade length(K) and opening max.(H) is the dimension adjusted for standard blade(AJ type). ※Air Pressure...NY10S: 0.4~0.5 Mpa/NY25S: 0.5~0.6MPa

Profile- SUS Tube  
型材、钢管

Stents Module  
支架模组

Quick Changer  
快换

Grip Module  
夹具组件

Air Nipper  
气动剪刀

Vacuum Module  
真空组件

Accessory Components  
附件

# 固定式气动剪刀NF系列

GT-NY05/10/15 Type-F Air Nippers

Profile, SUS Tube  
型材、钢管

Stents Module  
支架模组

Quick Changer  
快换

Grip Module  
夹具组件

Air Nipper  
气动剪刀

Vacuum Module  
真空组件

Accessory Components  
附件

# NF



本体设计小巧轻便, 便于设备内部及大量安装使用。  
these compact, lightweight nippers have been designed  
or easy mounting inside equipment and to enable secure  
mounting under high-density mounting conditions.

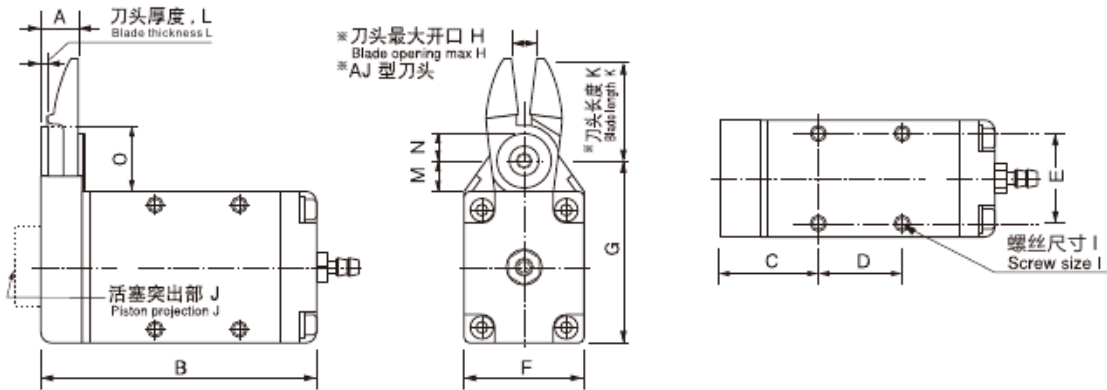

Capacity $\phi$ (mm)				Model No.	Size (mm)															Air Consumption (cm <sup>3</sup> /str.)	Weight (g)	Spec. & Size of the Hose Port
Soft Plastic	Hard Plastic	Copper	Steel		A	B	C	D	E	F	G	H	I	J	K	L	M	N	O			
3.0	2.0	1.6	1.0	GT-NF05	8.6	59.9	21.9	17	18	23	39.5	4	M3	3	22	1.6	8.4	6.25	16.4	43	101	W/hose nipple Hose I.D. $\phi$ 2.5mm $\times$ $\phi$ 4mm
3.5	2.3	1.7	1.1	GT-NF10	8.8	65.1	23.1	20	22	28	43.5	6	M3.5	5	24	1.6	7.4	6.25	15.4	63	143	
4.0	2.6	1.8	1.2	GT-NF15	10.2	73	25	25	26	33	48.5	8	M4	5	27	2	7.4	6.25	16.4	128	219	

※Blade opening max.(K) is the dimension adjusted for standard blade(AJ type).Mounting screw for NF10(M3.5) is regarded as spare part. ※Air Pressure...0.4-0.5 Mpa

# 剪刀本体NY系列 **NEW**

## NY Series Scissors

支持动作检测  
滑动式剪刀, 有效利用现场空间  
机身紧凑, 高效剪切

Supports motion detection  
Sliding shears for efficient use of workspace  
Compact design for efficient cutting

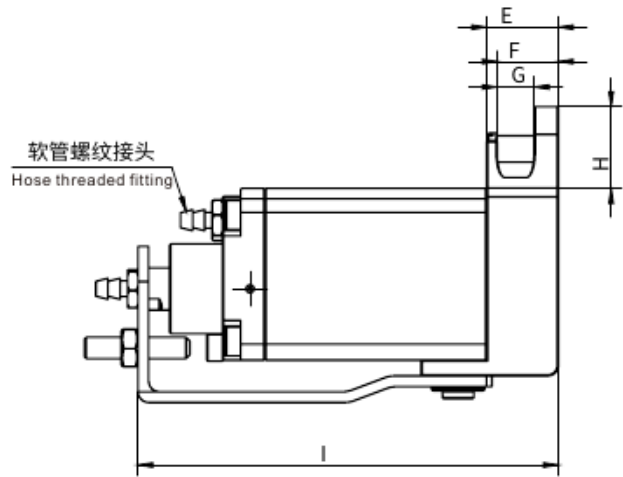
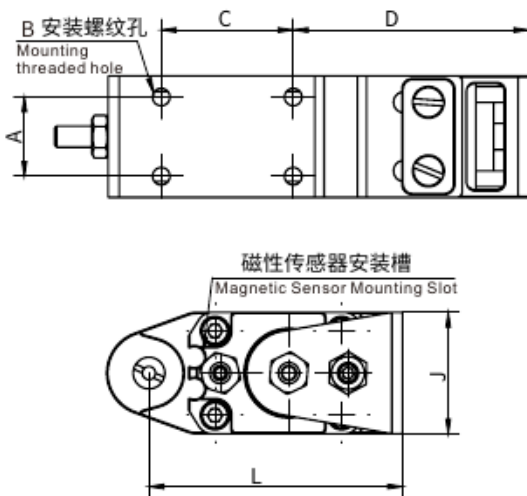

货号 PN	型号 Model	A	B	C	D	E	F	G	H	I	J	L	重量 weight
8.Y01386	GT-NY05P	15	4*M4	25	44.6	13.6	11.6	7	15.5	79.63	23	48.03	138g
8.Y00270	GT-NY10P	20	4*M4	30	45.1	14	12.35	7.35	14	84.8	28	53	193g
8.Y00249	GT-NY15P	25	4*M4	35	47	15.5	13.5	8.5	15	95.5	33	58	283g
8.Y01387	GT-NY25P	30	4*M5	40	55.2	18.2	15.2	10.2	18.6	109.7	42	69.5	512g

货号 PN	型号 Model	空气消耗量 $\text{cm}^3$ Air consumption ( $\text{cm}^3$ )	滑动方向/距离 (mm) Sliding direction/distance (mm)	软管接口规格与尺寸 Hose Connector Specifications and Dimensions
8.Y01386	GT-NY05P	48	拉(Pull)/0-3	软管接头(Hose connector) ID $\phi$ 2.5mm 管接头(Pipe fitting) ID $\phi$ 2.5mm OD $\phi$ 4mm
8.Y00270	GT-NY10P	68	拉(Pull)/0-3	软管接头(Hose connector) ID $\phi$ 2.5mm 管接头(Pipe fitting) ID $\phi$ 2.5mm OD $\phi$ 4mm
8.Y00249	GT-NY15P	136	拉(Pull)/0-3	软管接头(Hose connector) ID $\phi$ 2.5mm 管接头(Pipe fitting) ID $\phi$ 2.5mm OD $\phi$ 4mm
8.Y01387	GT-NY25P	190	拉(Pull)/0-5	软管接头(Hose connector) ID $\phi$ 2.5mm 管接头(Pipe fitting) ID $\phi$ 2.5mm OD $\phi$ 4mm

Profile- SUS Tube  
型材、钢管

Stents Module  
支架模组

Quick Changer  
快换

Grip Module  
夹具组件

Air Nipper  
气动剪刀

Vacuum Module  
真空组件

Accessory Components  
附件

# 滑动式气动 横向型 搭配刀头

## Slide-off Air Nipper Horizontal-type Blades

### AJ/RAJ/AJB



#### 树脂用直刀(塑料)

Straight blades for plastic(Plastic)

AJ/刀刃水平,无倾斜角,可垂直剪切。RAJ/AJ的反刃刀头。AJB/AJ的加硬刀头,用于剪切硬塑料或含有玻璃纤维的塑料,提高耐用性。

AJ/ This is a vertical set of blades with an unbeveled cutting edge. You can apply it at a right angle to the gate. RAJ/ This is a reverse bevel of AJ type. AJB/ This has a brazed carbide tip, suitable for cutting hard plastic or plastic containing glass fiber.

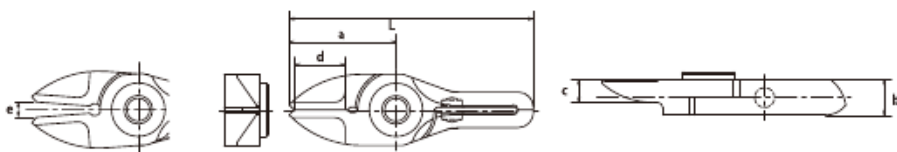

Model No.	Size (mm)					L	Weight (g)	Material	Application model
	a	b	c	d	e				
NY03AJ	21	7	4.5	10.5	3	48	17	Special alloy steel	GT-NY03G(-4)
NY03RAJ	21	7	4.5	10.5	3	48	17	Special alloy steel	GT-NY03GR(-4)
NY05AJ	22	7	5	10.5	4	53	22	Special alloy steel	GT-NY05(-4) / NF05
NY05RAJ	22	7	5	10.5	4	53	22	Special alloy steel	GT-NY05R(-4) / NF05
NY05AJB	22	7	5	10.5	4	53	22	Sintered Alloy	GT-NY05(-4) / NF05
NY10AJ	24	7.2	5	12	6	57	28	Special alloy steel	GT-NY10(-4) / NY10G(-4) / NF10 / NY10S
NY10RAJ	24	7.2	5	12	6	57	28	Special alloy steel	GT-NY10R(-4) / NY 10GR(-4) / NF10 / NY10S
NY10AJB	24	7.2	5	12	6	57	28	Sintered Alloy	GT-NY10(-4) / NY 10GR(-4) / NF10 / NY10S
NY15AJ	27	8.2	5.5	13	8	65	41	Special alloy steel	GT-NY15(-4) / NF15
NY15RAJ	27	8.2	5.5	13	8	65	41	Special alloy steel	GT-NY15R(-4) / NF15
NY15AJB	27	8.2	5.5	13	8	65	41	Sintered Alloy	GT-NY15(-4) / NF15
NY25AJ	31	10	6	16	9	77	65	Special alloy steel	GT-NY25(-6) / NY 25S
NY25RAJ	31	10	6	16	9	77	65	Special alloy steel	GT-NY25R(-6) / NY 25S
NY25AJB	31	10	6	16	9	77	65	Sintered Alloy	GT-NY25(-6) / NY 25S

### AJL



#### 树脂用加长直刀(塑料)

Straight long blades for plastic(Plastic)

AJL/这是一个加长型的直刀头。适用于刀头与浇口之间距离较远时。

AJL/ This is a long type set of straight blades. This is useful when there is distance between the nippers and the gate cut portion of the workpiece.

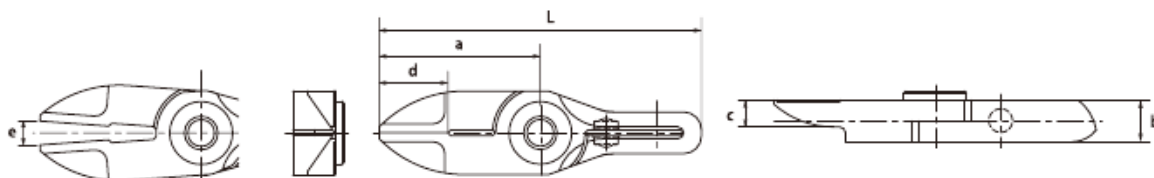

Model No.	Size (mm)					L	Weight (g)	Material	Application model
	a	b	c	d	e				
NY03AJL	27	7	4.5	10.5	4	54	21	Special alloy steel	GT-NY03G(-4)
NY05AJL	31	7	5	10.5	5.5	62	29	Special alloy steel	GT-NY05(-4) / NF05
NY10AJL	33	7.2	5	12	8	66	37	Special alloy steel	GT-NY10(-4) / NY10G(-4) / NF10 / NY10S
NY15AJL	38	8.2	5.5	13	11	76	50	Special alloy steel	GT-NY15(-4) / NF15
NY25AJL	46	10	6	16	13	92	88	Special alloy steel	GT-NY25(-6) / NY 25S

## 滑动式气动 横向型 搭配刀头

### Slide-off Air Nipper Horizontal-type Blades

#### AJT



#### 树脂用薄刃直刀(塑料)

Thin, straight blades for plastic(Plastic)

AJT/ 这是一组具有薄切刃的直刀头。它可以很干净地修剪横截面，不留下残余物。

AJT/ This is a set of straight blades with a thin cutting edge. It can cleanly trim cross sections without remnants.

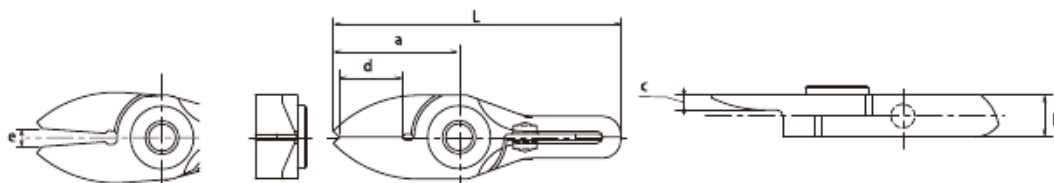

Model No.	Size (mm)						Weight (g)	Material	Application model
	a	b	c	d	e	L			
NY03AJT	21	7	2.5	10.5	3	48	17	Special alloy steel	GT-NY03G(-4)
NY05AJT	22	7	3	10.5	4	53	21	Special alloy steel	GT-NY05(-4) / NF05
NY10AJT	24	7.2	3	12	6	57	26	Special alloy steel	GT-NY10(-4) / NY10G(-4) / NF10 / NY10S
NY15AJT	27	8.2	3.5	13	8	65	38	Special alloy steel	GT-NY15(-4) / NF15

#### AD



#### 树脂用立体双面带刃刀头(塑料)

Lift blades for plastic(Plastic)

AD/ 双面连接浇口的剪切。

AD/ This is used for batch processing of the three-dimensional gate such as ride gate.

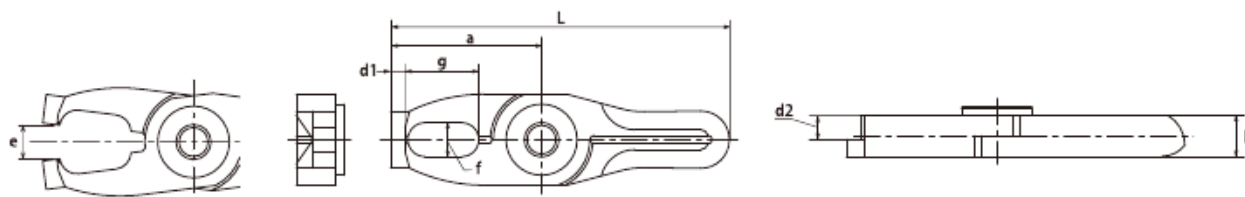

Model No.	Size (mm)			d1 (mm)	d2 (mm)	e (mm)	L (mm)	Weight (g)	Material	Application model
	a	b	f×g							
NY10AD	26.5	7.2	6×13	2.5	4.2	6	59.5	31	Special alloy steel	GT-NY10(-4) / NY10G(-4) / NF10 / NY10S
NY15AD	30	8.2	7×14	3	4.7	8	68	45	Special alloy steel	GT-NY15(-4) / NF15
NY25AD	35	10	8×17	4	6	9	81	75	Special alloy steel	GT-NY25(-6) / NY 25S

# 滑动式气动 横向型 搭配刀头

## Slide-off Air Nipper Horizontal-type Blades

Profile, SUS Tube  
型材、钢管

Stents Module  
支架模组

Quick Changer  
快换

Grip Module  
夹具组件

Air Nipper  
气动剪刀

Vacuum Module  
真空组件

Accessory Components  
附件

### AH/RAH



#### 树脂用L型刀头(塑料)

Crank blades for plastic(Plastic)

AH/ 刀头前端成L型, 有障碍物或浇口狭窄时有效。  
RAH/ AH的反刃刀头。

AH/ This is a set of blades with a clamped cutting edge for plastic. It is effective when there are obstructions or the gate is narrow.  
RAH/ This is a reverse bevel of AH type used when installing the main units face-to-face.

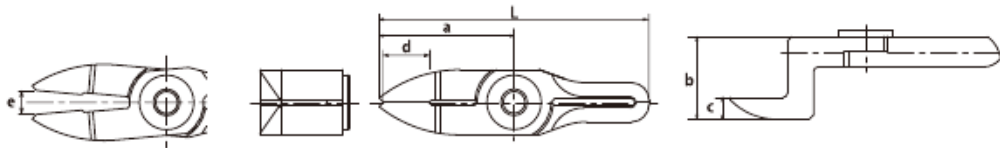

Model No.	a	b	c	Size (mm)			Weight (g)	Material	Application model
				d	e	L			
NY05AH	31	19	5	10.5	5.5	62	37	Special alloy steel	GT-NY05(-4) / NF05
NY05RAH	30	12	5	10.5	5	61	31	Special alloy steel	GT-NY05R(-4) / NF05
NY10AH	33	20	5	12	8	66	43	Special alloy steel	GT-NY10(-4) / NY10G(-4) / NF10 / NY10S
NY15AH	38	21.5	5.5	13	11	76	63	Special alloy steel	GT-NY15(-4) / NF15
NY15RAH	35	13.2	5.5	13	9	73	52	Special alloy steel	GT-NY15R(-4) / NF15
NY25AH	46	24	6	17	13	92	110	Special alloy steel	GT-NY25(-6) / NY 25S
NY25RAH	42	16	6	16	12	88	89	Special alloy steel	GT-NY25R(-6) / NY 25S

### BJ/RBJ



#### 金属用直刀头(金属)

Lift blades for plastic(Metal)

BJ/刀刃水平, 无倾斜角, 可垂直剪切。RBJ /BJ的反刃刀头。

BJ/ This is a set of vertical blades with an unbeveled cutting edge for metal. RBJ/ This is a reverse bevel of BJ type.

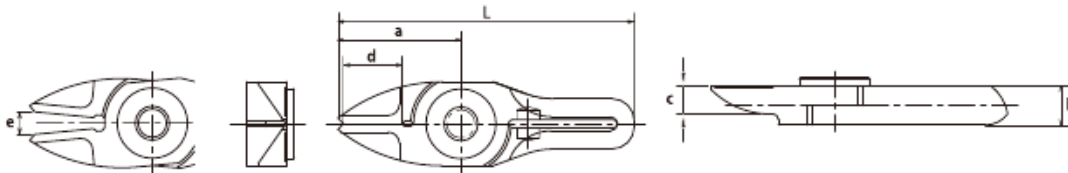

Model No.	a	b	c	Size (mm)			Weight (g)	Material	Application model
				d	e	L			
NY05BJ	22	7	5	10.5	4	53	22	Special alloy steel	GT-NY05(-4) / NF05
NY05RBJ	22	7	5	10.5	4	53	22	Special alloy steel	GT-NY05R(-4) / NF05

# 滑动式气动剪刀NT系列 纵向型

GT-NY03/05/10/20 Slide-Off Air Nippers Vertical-Type

NT



刀刃开口大小可微调, 确保剪切面不产生碎屑。  
刀头不分正刃反刃, 可同时对应[推出型]和[拉回型]本体。  
Blade gape is adjustable, and fine adjustments are easy to make after mounting the nippers, ensuring clean, unblemished cut surfaces

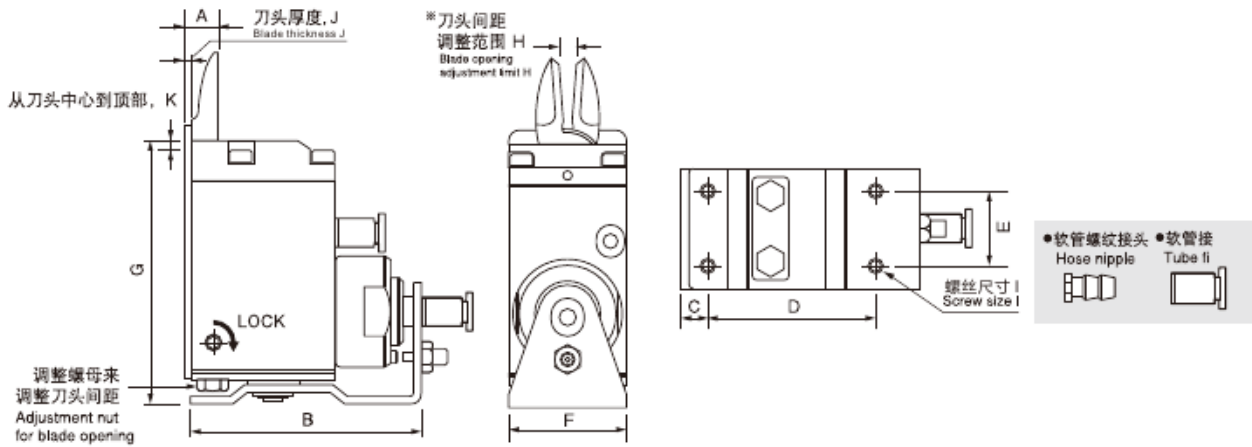

Capacity φ (mm) Soft Plastic Hard Plastic	Model No.	Size (mm)										Air Consumption (cm <sup>3</sup> /str)	Wgtr (g)	Slide Direction Distance (mm)	Spec. & Size of the Hose Port		
		A	B	C	D	E	F	G	H	I	J					K	
1.5 1.0	GT-NT03																
1.5 1.0	GT-NT03R																
1.5 1.0	GT-NT03-4	9	62	7	43	14	19	68.1	1.5~3	M3	2	5	27	178	Pull 0~3	W/hose nipple Hose I.D. φ2.5mm	
1.5 1.0	GT-NT03R-4												27	178	Push 0~3	W/tube fitting Hose I.D. φ2.5XO.D. φ4mm	
2.5 1.5	GT-NT05																
2.5 1.5	GT-NT05R																
2.5 1.5	GT-NT05-4	9	64	7	45	20	32	71.1	3~6	M4	2	5	47	325	Pull 0~3	W/hose nipple Hose I.D. φ2.5mm	
2.5 1.5	GT-NT05R-4												47	325	Push 0~3	W/tube fitting Hose I.D. φ2.5XO.D. φ4mm	
2.5 1.5	GT-NT05-6												47	325	Push 0~3	W/tube fitting Hose I.D. φ2.5XO.D. φ4mm	
3.5 2.3	GT-NT10																
3.5 2.3	GT-NT10R																
3.5 2.3	GT-NT10-6	11	73	8	53	24	38	88.1	4~7	M4	2	5	82	515	Pull 0~3	W/hose nipple Hose I.D. φ2.5mm	
3.5 2.3	GT-NT10R-6												82	515	Push 0~3	W/tube fitting Hose I.D. φ4XO.D. φ6mm	
5.0 3.4	GT-NT20																
5.0 3.4	GT-NT20R																
5.0 3.4	GT-NT20-6	14	103	10	80	28	44	102.1	4.5~9	M5	2	6	203	930	Pull 0~8	W/hose nipple Hose I.D. φ4mm	
5.0 3.4	GT-NT20R-6												203	930	Push 0~8	W/tube fitting Hose I.D. φ4XO.D. φ6mm	

※Blade opening adjustment limit (H) is the dimension adjusted for standard blade(AJ type).※ Air Pressure...0.4~0.5 MPa

Profile、SUS Tube  
型材、钢管

Stents Module  
支架模组

Quick Changer  
快换

Grip Module  
夹具组件

Air Nipper  
气动剪刀

Vacuum Module  
真空组件

Accessory Components  
附件

# 滑动式气动剪刀 纵向型 搭配刀头

## Slide-off Air Nipper Vertical-type Blades

### AJ/AJH/AJB



#### 树脂用直刀头(塑料)

Straight blades for plastic(Plastic)

AJ/刀刃水平,无倾斜角,可垂直剪切。AJH/AJ的加硬刀头(硬质合金)提高耐用性。AJB/AJ的加硬刀头(超硬碳钢),用于剪切硬塑料或含有玻璃纤维的塑料,提高耐用性。

AJ/ This is a set of vertical blades with an unbeveled cutting edge.

You can apply it at a right angle to the gate. AJH/ This has a brazed high-speed steel tip suitable for cutting hard plastic. AJB/ This has a brazed carbide tip used for cutting hard plastic or plastic containing glass fiber. Improved durability.

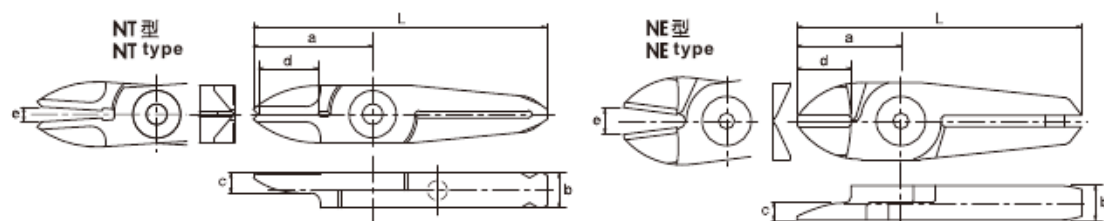

Model No.	Size (mm)						Weight (g)	Material	Application model
	a	b	c	d	e	L			
NT03AJ	24	7	4	11	3	59	20	Special alloy steel	GT-NT03 type
NT05AJ	29	7	5	15	6	65	30	Special alloy steel	GT-NT05 type
NT05AJH	29	7	5	15	6	65	30	High Speed Steel	
NT05AJB	29	7	5	15	6	65	30	Sintered Alloy	
NESAJ	24	7	3.5	12	6	60	35	Special alloy steel	GT-NT10 type
NT10AJ	35	9	6	17	7	82	62	Special alloy steel	
NT10AJH	35	9	6	17	7	82	76	High Speed Steel	
NT10AJB	35	9	6	17	7	82	76	Sintered Alloy	GT-NT20 type
NE10AJ	27	9	4.5	12	7	74	70	Special alloy steel	
NT20AJ	40	12	6	20	9	97	120	Special alloy steel	
NT20AJH	40	12	6	20	9	97	120	High Speed Steel	GT-NT20 type
NT20AJB	40	12	6	20	9	97	120	Sintered Alloy	

# 滑动式气动剪刀 纵向型 搭配刀头

Slide-off Air Nipper Vertical-type Blades

## AJL



### 树脂用加长直刀(塑料)

straight long blades for plastic(Plastic)

AJL/AJ的刀刃加长型, 刀头与浇口距离较远时有效。

AJL/ This is a long type set of straight blades. This is useful when there is distance between the nippers and the gate cut portion of the workpiece.

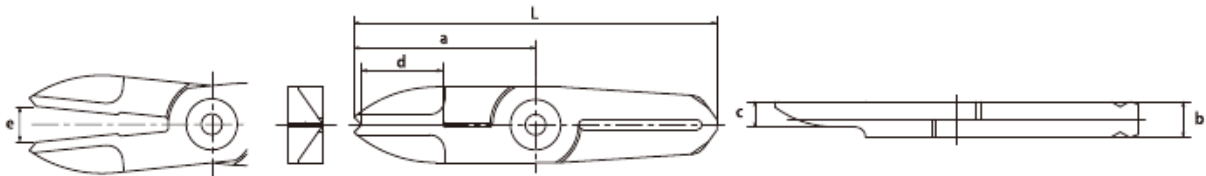

Model No.	a	b	Size (mm)			L	Weight (g)	Material	Application model
NT05AJL	36	7	5	15	7	72	39	Special alloy steel	GT-NT05 type
NT10AJL	47	9	6	17	9	94	62	Special alloy steel	GT-NT10 type
NT20AJL	57	12	6	20	12	114	156	Special alloy steel	GT-NT20 type

## AJT



### 树脂用薄刃直刀(塑料)

Thin, straight blades for plastic(Plastic)

AJT/AJ的薄刃直刀, 高精度剪切, 不留残余物。

AJT/ This is a set of straight blades with a thin cutting edge. It can cleanly finish cross sections without remnants.

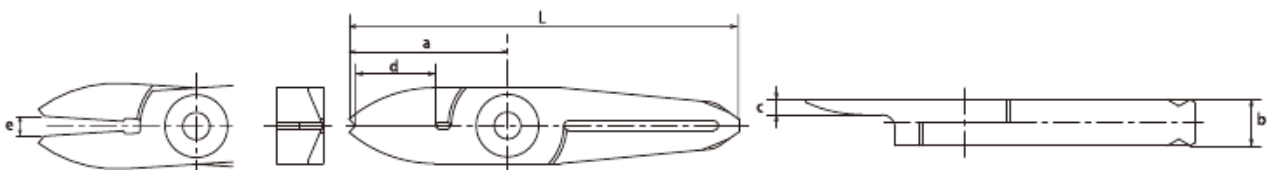

Model No.	a	b	Size (mm)			L	Weight (g)	Material	Application model
NT03AJT	24	7	2.3	11	3	59	19	Special alloy steel	GT-NT03 type
NT05AJT	29	7	3	15	6	65	29	Special alloy steel	GT-NT05 type
NT10AJT	35	9	4	17	7	82	65	Special alloy steel	GT-NT10 type

Profile- SUS Tube  
型材、钢管

Stents Module  
支架模组

Quick Changer  
快换

Grip Module  
夹具组件

Air Nipper  
气动剪刀

Vacuum Module  
真空组件

Accessory Components  
附件

# 滑动式气动剪刀 纵向型 搭配刀头

## Slide-off Air Nipper Vertical-type Blades

Profile, SUS Tube  
型材、钢管

Stents Module  
支架模组

Quick Changer  
快换

Grip Module  
夹具组件

Air Nipper  
气动剪刀

Vacuum Module  
真空组件

Accessory Components  
附件

### AJY



#### 树脂用薄型直刀(塑料)

Thin, straight blades for plastic(Plastic)

AJL/AJ的刀刃加长型, 刀头与浇口距离较远时有效。

AJL/ This is a long type set of straight blades. This is useful when there is distance between the nippers and the gate cut portion of the workpiece.

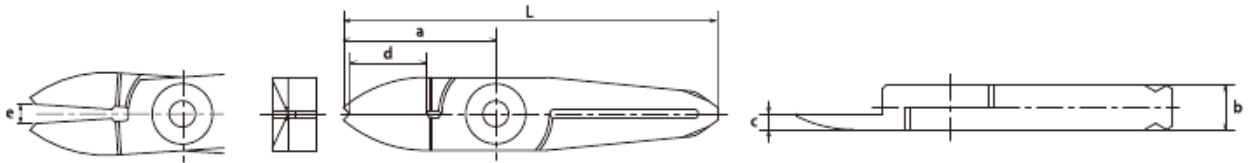

Model No.	Size (mm)						Weight (g)	Material	Application model
	a	b	c	d	e	L			
NT03AJY	24	7	2.5	11	3	59	19	Special alloy steel	GT-NT03 type
NT05AJY	29	7	5	15	6	65	29	Special alloy steel	GT-NT05 type
NT10AJY	35	9	4	17	7	72	82	Special alloy steel	GT-NT10 type

### AD



#### 树脂用立体双面带刃刀头(塑料)

Lift blades for plastic(Plastic)

AD/ 处理搭接浇口有效。

AD/ This is used for batch processing of the three-dimensional gate such as ride gate.

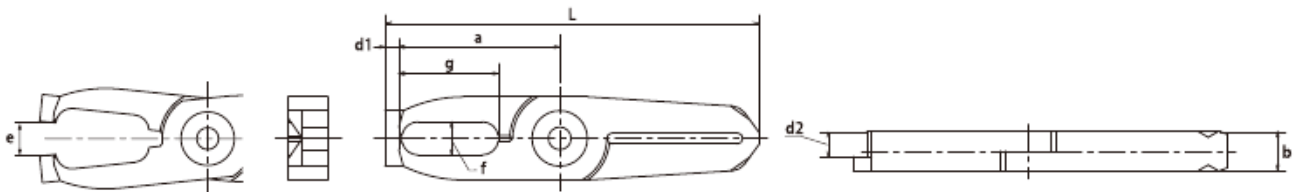

Model No.	Size (mm)			d1 (mm)	d2 (mm)	e (mm)	L (mm)	Weight (g)	Material	Application model
	a	b	f×g							
NT05AD	31.5	7	6×18	2.5	4.5	6	67.5	37	Special alloy steel	GT-NT05 type
NT10AD	39	9	8×21.5	4	5	7	86	65	Special alloy steel	GT-NT10 type
NT20AD	46	12	9×24.5	6	7	9	103	141	Special alloy steel	GT-NT20 type

# 滑动式气动剪刀 纵向型 搭配刀头

Slide-off Air Nipper Vertical-type Blades

## AJV



### 树脂用V刃直刀(塑料)

V shaped straight blades for plastic(Plastic)

AJV/处理曲面浇口或剪切后必须无残留时有效。

AJV/ This is suitable for gate processing when the cross section is curved or the cut end must not be left.

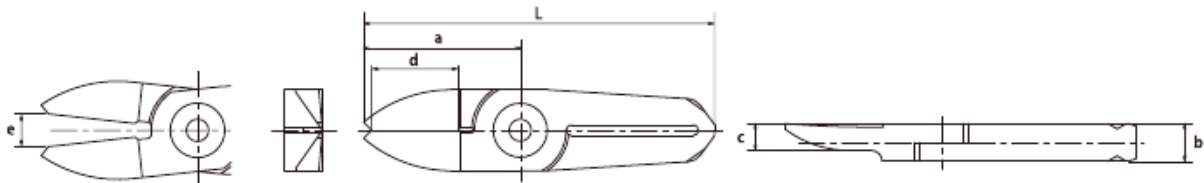

Model No.	Size (mm)						Weight (g)	Material	Application model
	a	b	c	d	e	L			
NT05AJV	29	7	5	15	6	65	29	Special alloy steel	GT-NT05 type
NT10AJV	35	9	6	17	7	82	63	Special alloy steel	GT-NT10 type

## AE



### 树脂用剪钳刀头(塑料)

Nipping blades for plastic(Plastic)

AE/处理直接浇口和搭接浇口时有效。

AE/ Used for processing plastic gates such as ride gates and discard gates.

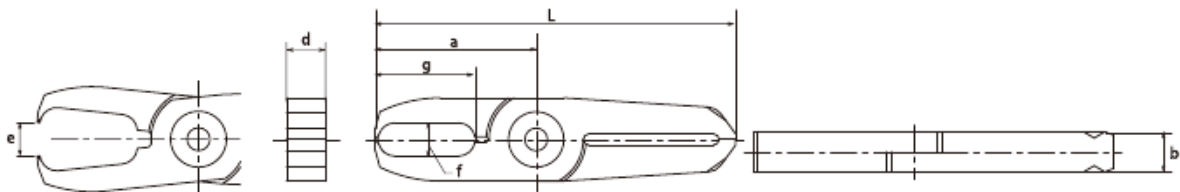

Model No.	Size (mm)						Weight (g)	Material	Application model
	a	b	f×g	d	e	L			
NT05AE	29	7	6×18	7	6	65	36	Special alloy steel	GT-NT05 type
NT10AE	35	9	8×21.5	9	7	82	75	Special alloy steel	GT-NT10 type

Profile- SUStube  
型材、钢管

Stents Module  
支架模组

Quick Changer  
快换

Grip Module  
夹具组件

Air Nipper  
气动剪刀

Vacuum Module  
真空组件

Accessory Components  
附件

## 推刀式气动剪刀 GT-NK10 Thrust-cut Air Nipper

Profile, SUS Tube  
型材、钢管

Stents Module  
支架模组

Quick Changer  
快换

Grip Module  
夹具组件

Air Nipper  
气动剪刀

Vacuum Module  
真空组件

Accessory Components  
附件

# NK

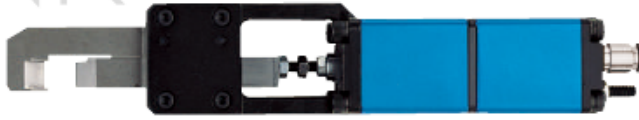

该气剪可以配合脚踏开关或高精度机器切割薄膜浇口。从薄端切割,防止切割边缘周围的皱褶。

These nippers are equipped with a foot switch and are linked to high precision drivers, enabling the cutting of film-shaped gates from the thin end, preventing wrinkles around the cut.

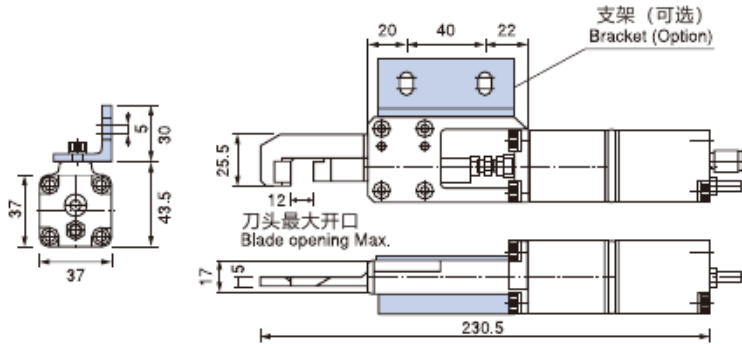

Capacity $\phi$ (mm) ABS Plastic	Model No.	Air Consumption (cm <sup>3</sup> /str.)	Air Pressure (MPa)	Weight (g)	Applied Pressure (N)	Spec. & Size of the Hose Port
5	GT-NK10	110	0.4~0.5	800	735	Hose I.D. $\phi$ 2.5XO.D. $\phi$ 4mm

※Hose Coupling: I.D.  $\phi$ 4\*O.D.  $\phi$ 6mm  
※Piston stroke...Max.12mm

## 推刀式气动剪刀专用刀头 Thrust-cut Air Nipper blades

### NK10AJ



这是一组专用的GT-NK10刀头。

适合处理附在机器人手上的薄膜浇口。

This is a dedicated set of blades for GT-NK10.

Suitable for processing of film gates attached to robot hands

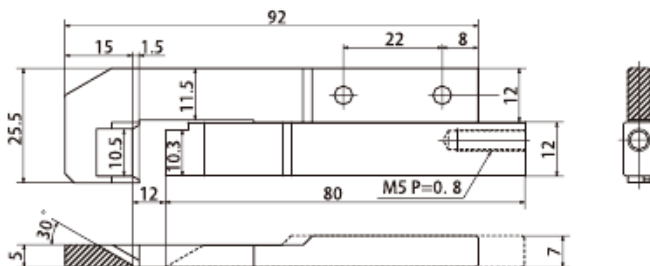

Model No.	Size (mm)	Shape	O.A.L. (mm)	Weight (g)	Material	Application model
NK10AJ	As above	For metal cutting (Knife type)	95	96	Special alloy steel	GT-NK10

# 定时控制器

GT-TC-02 Timing Controller

TC

调节螺丝钉  
(0.5秒到1.5秒)  
Adjusting Screw  
(0.5~1.5 sec.)



通过在气源和气动剪刀之间安装此控制器，  
可以调整本体滑动和刀头剪切时间。  
(大约0.5秒到1.5秒)

Connected between the compressor and the air nippers,  
the timing controller enables adjustments to the slide and  
cutting timing. (Approximately 0.5 seconds to 1.5 seconds)

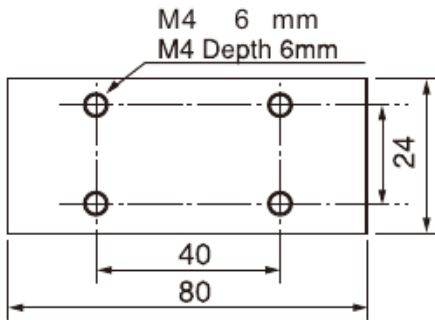
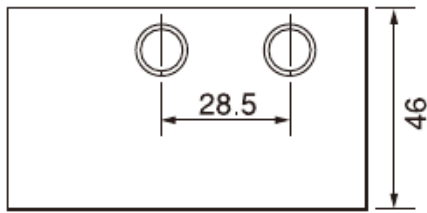

工作气压...0.6Mpa  
尺寸...高度46x长度80x厚度34 (mm)  
重量...275g  
气管接头:内直径φ4x外直径φ6mm  
Working air pressure ... 0.6MPa  
Size ... Height 46 X Length 80 X thickness 34 (mm)  
Weight ... 275 g With tube joint: I.D. φ4 X O.D. φ6 mm

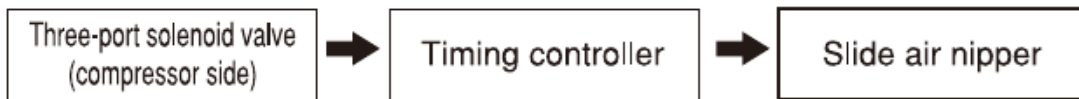
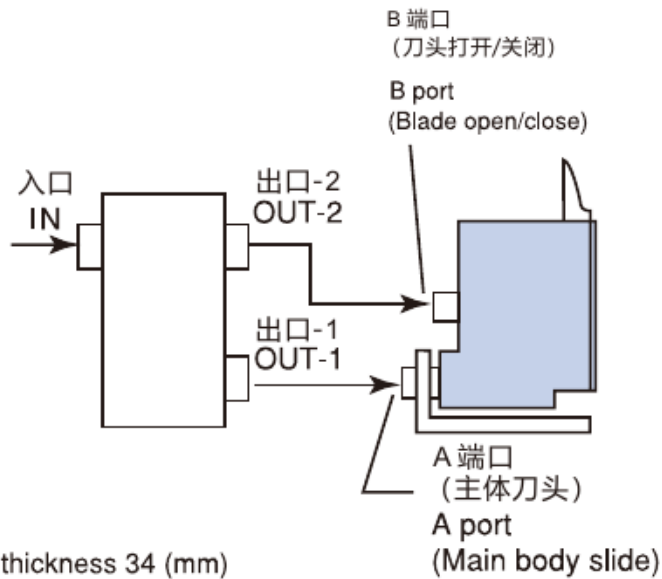

Connectable nippers (Reference)

No. GT-	NY05	NY10	NY15	NY25	NT03	NT05	NT10	NT20	NB20	NB30	NB20LW	NB30LW
Connectable unit	4	3	1	1	6	4	2	1	2	1	2	1
	(pcs)											

Profile- SUStube  
型材、钢管

Stents Module  
支架模组

Quick Changer  
快换

Grip Module  
夹具组件

Air Nipper  
气动剪刀

Vacuum Module  
真空组件

Accessory Components  
附件

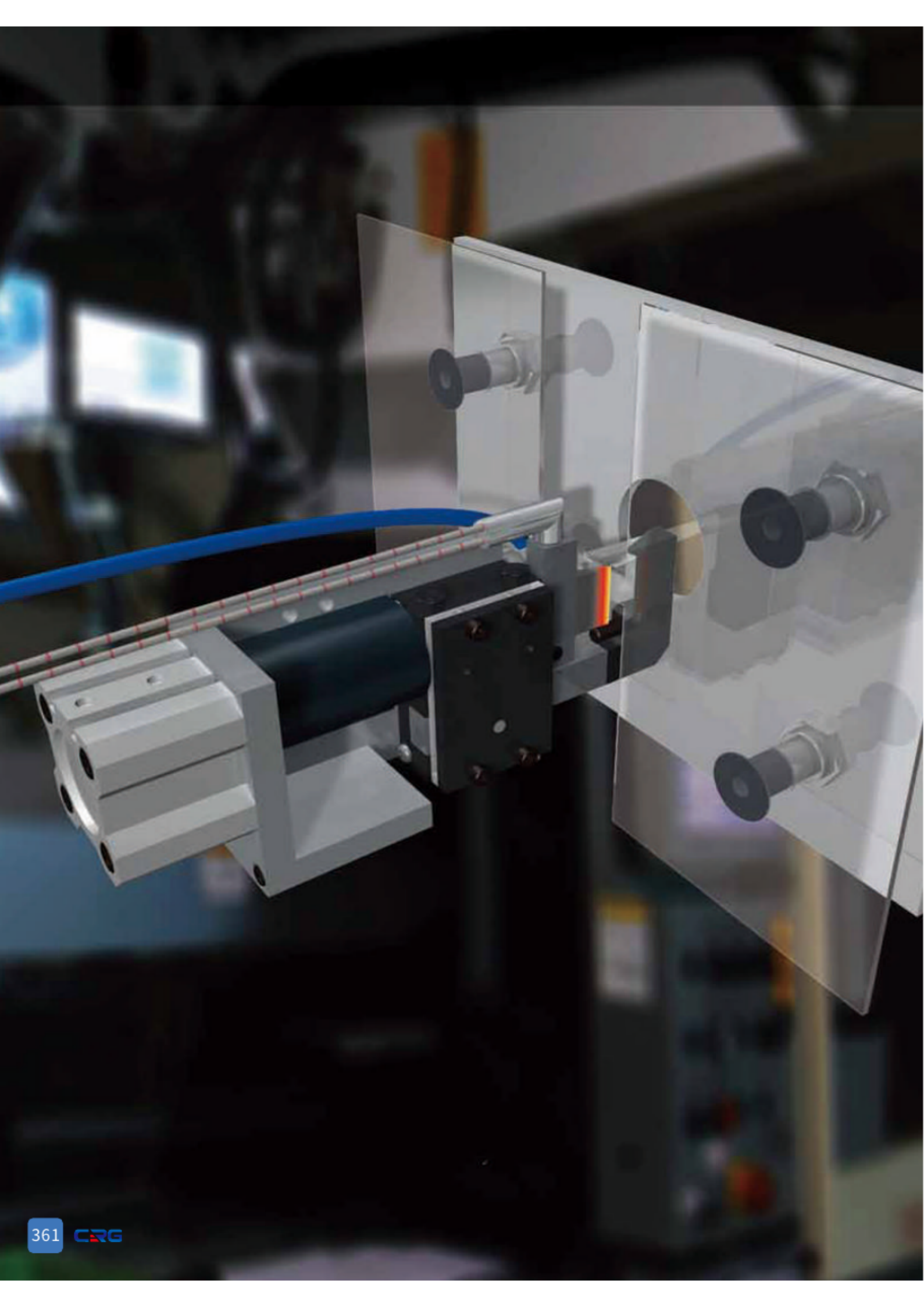

# 加热割刀 Heating Cutter

可切除料头, 去毛刺和修边。  
Remove sprue, deburr and teim.

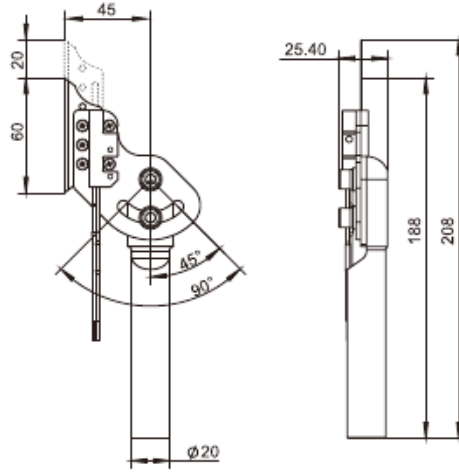

货号(PN)	型号(Model)	重量(Weight)
8.Y00346	GT-BH2060	186g

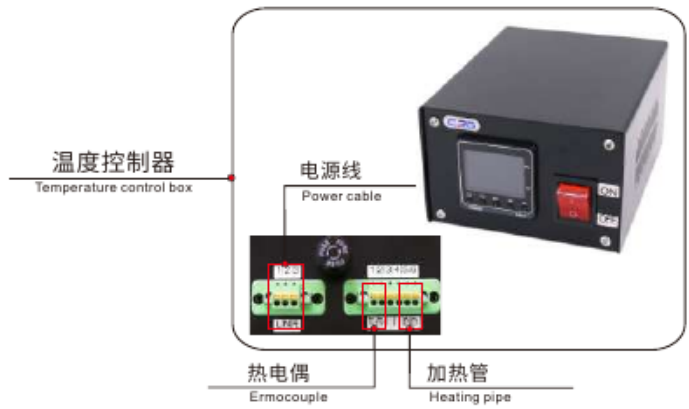
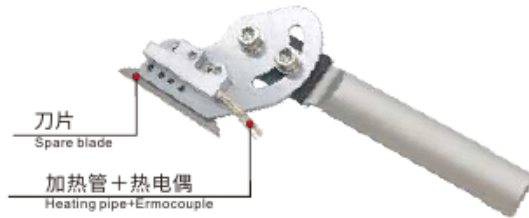

## 选配 Optional

	货号(PN)	型号(Model)	描述(Describe)
切割刀片 Cutting blades	2.Y04411	GT-BH20	-
温度控制器 ater control box	8.Y01026	GTC-001	-

Profile- SUS Tube  
型材、钢管

Stents Module  
支架模组

Quick Changer  
快换

Grip Module  
夹具组件

Air Nipper  
气动剪刀

Vacuum Module  
真空组件

Accessory Components  
附件

## 油压辅助型气动剪刀

### GT-N2010H-10 Heat Air Nippers

加热剪刀用于剪切一些气动剪刀剪不动的东西，并且可以增加剪切面美观度。

剪切厚度0-5mm。

温度最高可达 180 度。

采用了油压的方式，切割的力更大。

切割透明产品时，可以有效的抑制裂纹，使切割面更加美观。

Heated scissors are used to cut some things that pneumatic scissors can not cut, and can increase the beauty of the shear surface.

Cutting thickness 0-5mm.

Temperatures can reach up to 180°C degrees.

The method of oil pressure is adopted, and the cutting force is greater.

When cutting transparent products, cracks can be effectively suppressed to make the cutting surface more beautiful.

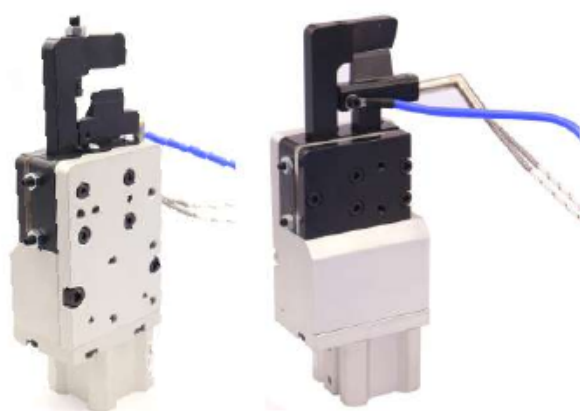

逆刀  
Reversed blade

正刀  
Broadsword

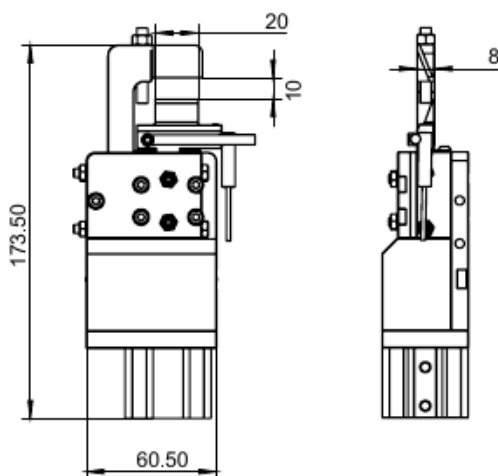

货号(PN)	8.Y01070	8.Y01258
型号(Model)	GT-N2010H-10	GT-N2010H-10(逆)

## 气液转换器

### Gas-liquid converter



货号(PN)	1.Y02005	型号(Model)	AHC32X50
--------	----------	-----------	----------

# 推入式气剪 **NEW**

## Thrust Cut Nippers

双动作气缸。  
 可选的磁传感器。  
 刀片加热系统。  
 可选配 (上 / 下刀片) 以及隔热垫等备件。

Double-acting cylinder.  
 Optional magnetic sensors .  
 blade heating system.  
 Optional (upper/lower blade) and spare parts such as thermal pads are available.

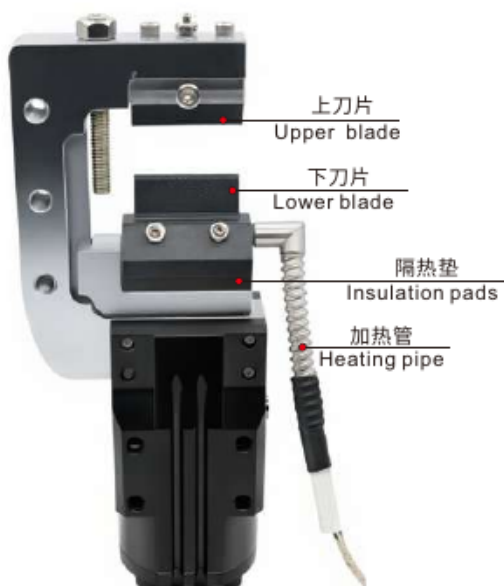

货号 PN	型号 Model	介质 Medium	压力范围 Pressure range	温度范围 Temperature range	活塞孔 Piston bore	6 bar压力下的 关闭扭矩 Closing torque at 6 bar	循环空气消耗量 Cycle air consumption	重量 Weight
8.Y01389	GT-N30H-32	已过滤, 润滑型 / 未润滑型压缩空气 Filtered, lubricated / non lubricated compressed air	2~ 6 bar	5 ~ 60 °C	Ø32 mm	482 Ncm	15 cm <sup>3</sup>	809g

## 选配 Optional

	上刀片 Upper blade	下刀片 lower blade	隔热垫 Insulation pads	温控线 Temperature control cable	加热管 Heating pipe	温度控制器 Ater control box	功率 Power	温度范围 Temperature range	操作电压 Operating voltage
货号 PN	7.Y03886	7.Y03887	7.Y03888	1.Y03689	7.Y03890	8.Y01026	100W	0-200°C	100-240Vac 50/60Hz
型号 Model	N30-T	N30-D	L37-14-5	K型(1.5米线) 精密型 Type K (1.5-meter cable) Precision type	L型, 长度37mm, 直径6 220V 100W 1.5米 L-shaped, 37 mm long, 6 mm diameter, 220 V, 100 W, 1.5 meters	GTC-001			

型材、钢管  
Profile, SUS Tube

支架模组  
Stents Module

快换  
Quick Changer

夹具组件  
Grip Module

气动剪刀  
Air Nipper

真空组件  
Vacuum Module

附件  
Accessory Components

# 推入式气剪 **NEW**

## Thrust Cut Nippers

Profile, SUS Tube  
型材、钢管

Stents Module  
支架模组

Quick Changer  
快换

Grip Module  
夹具组件

Air Nipper  
气动剪刀

Vacuum Module  
真空组件

Accessory Components  
附件

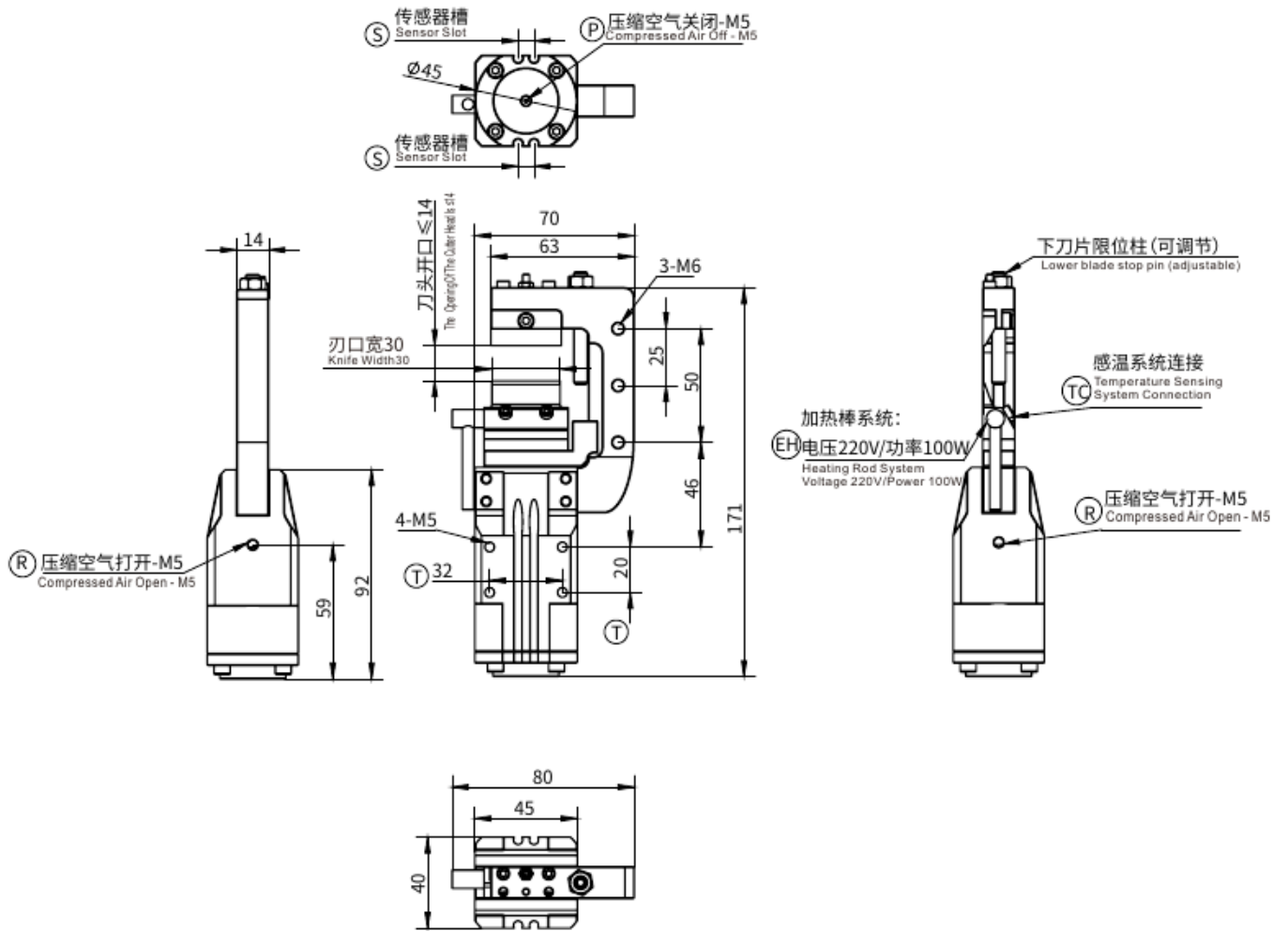

(P) 压缩空气接连: 关闭

(R) 压缩空气接连: 打开

(S) 传感器槽

(T) 紧固螺纹孔

(EH) 加热系统 外壳D=6.0

(TC) 热电偶感温系统

(P) Compressed air connection: CLOSING

(R) Compressed air connection: OPENING

(S) Sensor slot

(T) Threaded hole for fastening

(EH) Heating system housing  $\varnothing 6.0$

(TC) Thermocouple temperature sensing system

## 推入式气剪 Thrust Cut Nippers

双动作气缸。  
可选的磁传感器。  
刀片加热系统。  
可选配 (上 / 下刀片) 以及隔热垫等备件。  
可选逆刀, 详情请咨询我们

Double-acting cylinder.  
Optional magnetic sensor.  
Blade heating system.  
Optional accessories include (upper/lower blades) and heat-insulating pads.  
Reverse-cut blades are available; please contact us for more details.



货号 PN	型号 Model	介质 Medium	压力范围 Pressure range	温度范围 Temperature range	活塞孔 Piston bore	6 bar压力下的 关闭扭矩 Closing torque at 6 bar	循环空气消耗量 Cycle air consumption	重量 Weight
8.Y00367	GT-N50H-40	已过滤, 润滑型 / 未润滑型压缩空气 Filtered, lubricated / non lubricated compressed air	2~ 6 bar	5 - 60 °C	Ø40 mm	735 Ncm	75 cm <sup>3</sup>	1570g

### 选配 Optional

	上刀片 Upper blade	下刀片 lower blade	隔热垫 Insulation pads	温控线 Temperature control cable	加热管 Heating pipe	温度控制器 Ater control box	功率 Power	温度范围 Temperature range	操作电压 Operating voltage
货号 PN	7.Y00441	7.Y00442	2.Y05202	1.Y02628	1.Y02629	8.Y01026	100W	0-200°C	100-240Vac 50/60Hz
型号 Model	N54-T	N54-D	L54-5	K型1m 定制 Type k 1m	L-D6-LS1- H20-V220- W100-1500mm	GTC-001			

型材、钢管  
Profile, SUS Tube

支架模组  
Stents Module

快换  
Quick Changer

夹具组件  
Grip Module

气动剪刀  
Air Nipper

真空组件  
Vacuum Module

附件  
Accessory Components

# 推入式气剪

## Thrust Cut Nippers

Profile, SUS Tube  
型材、钢管

Stents Module  
支架模组

Quick Changer  
快换

Grip Module  
夹具组件

Air Nipper  
气动剪刀

Vacuum Module  
真空组件

Accessory Components  
附件

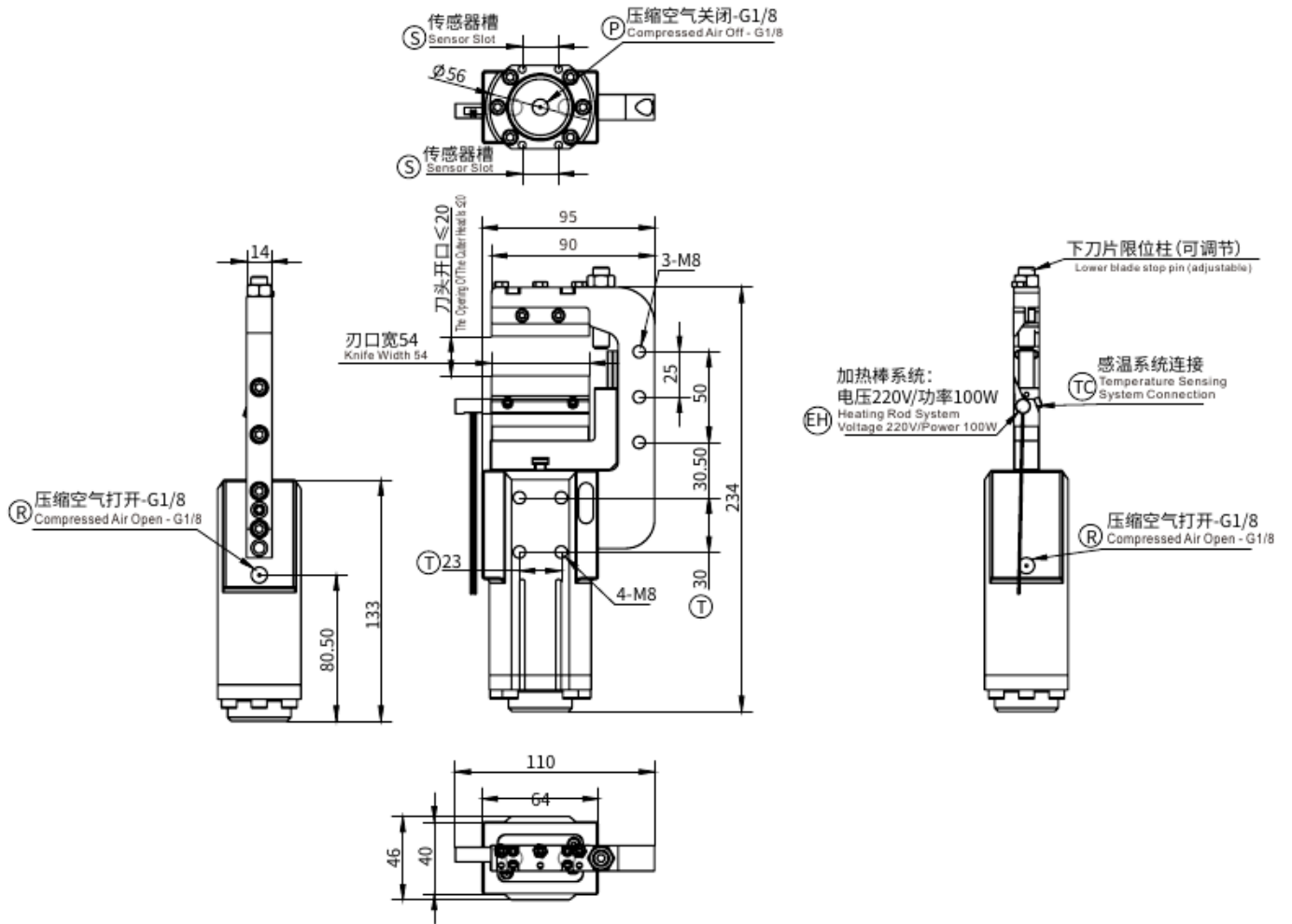

Ⓟ 压缩空气连接: 关闭

Ⓡ 压缩空气连接: 打开

Ⓢ 传感器槽

Ⓣ 紧固螺纹孔

ⓔⓗ 加热系统 外壳D=6.0

ⓉⓈ 热电偶感温系统

Ⓟ Compressed air connection: CLOSING

Ⓡ Compressed air connection: OPENING

Ⓢ Sensor slot

Ⓣ Threaded hole for fastening

ⓔⓗ Heating system housing  $\varnothing 6.0$

ⓉⓈ Thermocouple temperature sensing system

## 推入式气剪 Thrust Cut Nippers

双动作串联气缸。  
可选的磁传感器。  
刀片加热系统。  
可选配(上/下刀片)以及隔热垫等备件。

Double-acting operation with tandem cylinders.  
Optional magnetic sensors .  
blade heating system.  
Optional (upper/lower blade) and spare parts such as thermal pads are available.

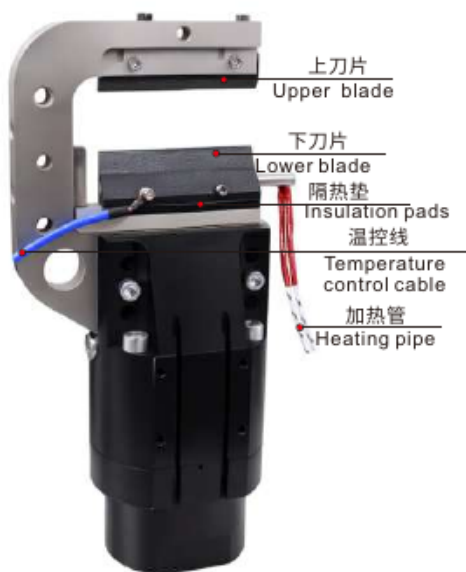

优点：  
长时间加热刀身温度不高,缸径比GT-N50H-40大,可以剪切比GT-N50H-40更厚的材料,同时刀头长度更长,最多可剪切长70mm的材料,采用外接热电偶的方式,使刀身温度更加精准

Advantages:  
long time heating of the cutter body temperature is not high, the cylinder diameter is larger than GT-N50H-40, you can cut thicker materials than GT-N50H-40, at the same time the cutter head length is longer, up to cut materials up to 70mm long, the use of external thermocouples, so that the cutter body temperature is more accurate.

货号 PN	型号 Model	介质 Medium	压力范围 Pressure range	温度范围 Temperature range	活塞孔 Piston bore	6 bar压力下的 关闭扭矩 Closing torque at 6 bar	循环空气消耗量 Cycle air consumption	重量 Weight
8.Y01055	GT-N80H-63	已过滤, 润滑型/ 未润滑型压缩空气 Filtered, lubricated / non lubricated compressed air	2~ 6 bar	5-60 °C	Ø63 mm	3648 Ncm	291 cm <sup>3</sup>	2.97Kg

### 选配 Optional

	上刀片 Upper blade	下刀片 lower blade	隔热垫 Insulation pads	温控线 Temperature control cable	加热管 Heating pipe	温度控制器 Ater control box	功率 Power	温度范围 Temperature range	操作电压 Operating voltage
货号 PN	7.Y03905	7.Y03906	7.Y03907	1.Y02002	1.Y02558	8.Y01026	100W	0-200°C	100-240Vac 50/60Hz
型号 Model	L81-20.8-4	L80-12.7-25	L80-12.8-4.5	K型(1.5米线) 精密型 Type K (1.5-meter cable) Precision type	MCHL6-80 -V220-W100	GTC-001			

型材、钢管  
Profile、SUS Tube

支架模组  
Stents Module

快换  
Quick Changer

夹具组件  
Grip Module

气动剪刀  
Air Nipper

真空组件  
Vacuum Module

附件  
Accessory Components

# 推入式气剪

## Thrust Cut Nippers

Profile, SUS Tube  
型材、钢管

Stents Module  
支架模组

Quick Changer  
快换

Grip Module  
夹具组件

Air Nipper  
气动剪刀

Vacuum Module  
真空组件

Accessory Components  
附件

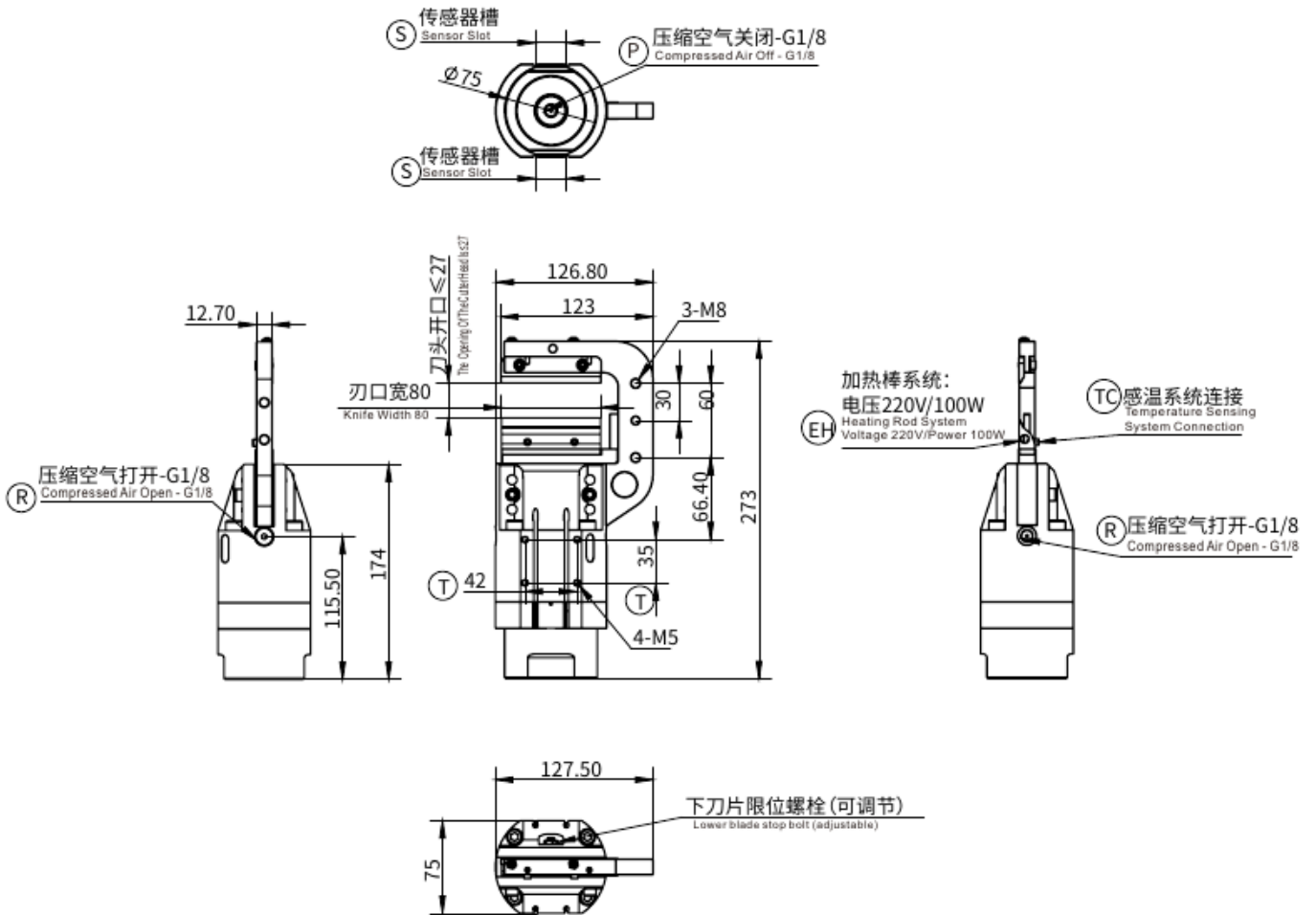

Ⓟ 压缩空气接连: 关闭

Ⓡ 压缩空气接连: 打开

Ⓢ 传感器槽

Ⓣ 紧固螺纹孔

ⓔⓗ 加热系统 外壳D=6.0

ⓉⓈ 热电偶感温系统

Ⓟ Compressed air connection: CLOSING

Ⓡ Compressed air connection: OPENING

Ⓢ Sensor slot

Ⓣ Threaded hole for fastening

ⓔⓗ Heating system housing  $\varnothing 6.0$

ⓉⓈ Thermocouple temperature sensing system

# 温度控制器

## Temperature Regulator

可制程温度监测和控制。  
 切换配置和编程简便。  
 能够控制几个串行连接的加热管。  
 易携带转换工作场所，连接便捷。

Process temperature monitoring and control is possible.  
 Switching configuration and programming is easy.  
 Capable of controlling several heating tubes connected in series.  
 Easy to carry and change the workplace, easy to connect.



GTC-001

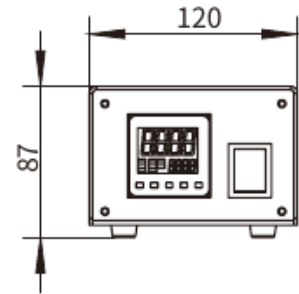
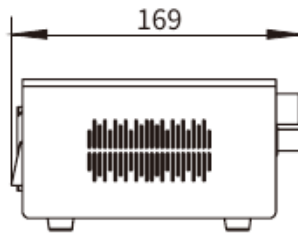

GTC-002

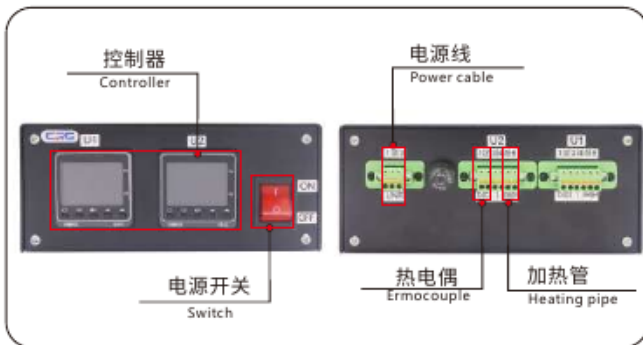
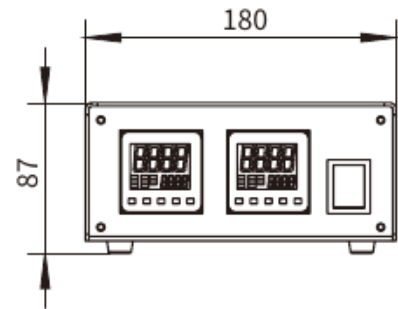
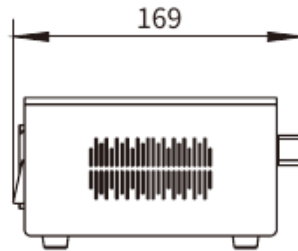

货号 NP	型号 Model	温度范围-热电偶K Temperature range- Thermocouple K	电源 Power supply	环境/存储温度 Ambient/ Storage temperature	保护保险丝 Protection fuse	重量 Weight
8.Y01026	GTC-001	0° ~ 200 °C	AC100-240V	0-50°C/10-65°C (避免结冰或结露) (Avoid icing or condensation)	内置15A一个 One built-in 15A	1268g
8.Y01027	GTC-002					1820g

Profile- SUS Tube  
型材、钢管

Stents Module  
支架模组

Quick Changer  
快换

Grip Module  
夹具组件

Air Nipper  
气动剪刀

Vacuum Module  
真空组件

Accessory Components  
附件

# 加热管/温控线

## Heating Pipe/Thermocouple control cable

Profile, SUS Tube  
型材、钢管

加热管功率 100 瓦。  
加热管直径 6。  
热电偶 (TC):K 型。  
易携带转换工作场所,连接便捷。

Heating tube power is 100W.  
Heating tube  $\phi$  6.  
Thermocouple (TC): K type.  
Easy to carry and change the workplace, easy to connect.

Stents Module  
支架模组



加热管  
Heating pipe

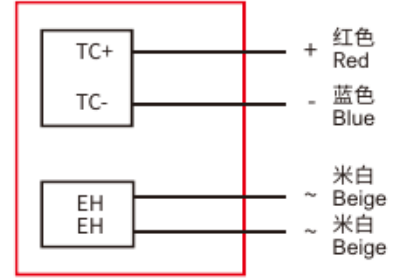

Quick Changer  
快换

Grip Module  
夹具组件

货号 PN	型号 Model	适用加热推刀 Suitable for heated scrapers
7.Y03890	L型, 长度37mm, 直径6 220V 100W 1.5米 L-shaped, 37 mm long, 6 mm diameter, 220 V, 100 W, 1.5 meters	GT-N30H-32
1.Y02629	L-D6-LS1-H20-V220-W100-1500mm	GT-N50H-40
1.Y02558	MCHL6-80-V220-W100	GT-N80H-63

Air Nipper  
气动剪刀



温控线  
Thermocouple control cable

Vacuum Module  
真空组件

货号 PN	型号 Model	适用加热推刀 Suitable for heated scrapers
1.Y03689	K型(1.5米线)精密型 Type K (1.5-meter cable) Precision type	GT-N30H-32
1.Y02628	K型1m 定制 Type k 1m	GT-N50H-40
1.Y02002	K型(1.5米线)精密型 Type K (1.5-meter cable) Precision type	GT-N80H-63

Accessory Components  
附件



# 油压辅助型气动剪刀 (推刀式)

GT-NKH20A/20AR Heat Air Nippers (Air Hydro Type)

# NKH

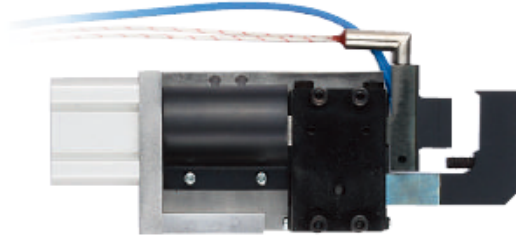

气动+油压控制确保强大剪切能力。  
适用于光学树脂镜片等产品的高精度剪切。  
Air-hydro cylinders produce high power from air and oil.  
These units are ideal for high precision cuts required for products such as optical resin lenses.

需要另外购买液压控制器。  
可定制刀头长度和气缸大小。  
\*Requires separately sold Hydro Controller.  
\*Custom-made blade lengths and cylinder capacities available

## GT-NKH20A-25 (正刃) GT-NKH20A-25 (Forward-facing blades)

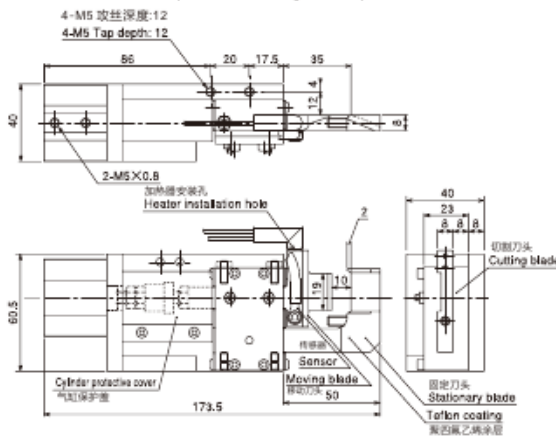

## GT-NKH20AR-25 (反刃) GT-NKH20AR-25 (Backward-facing blades)

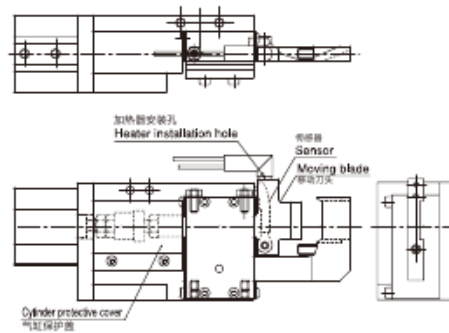

Model No.	Cutting Capacity φ (mm) Acrl	Blade Edge Temp. (MAX. °C)	Air Consumption (cm <sup>3</sup> /str.)	Piston Stroke (mm)	Weight (g)
GT-NKH20A-25/20AR-25	10x1.5	180	60	10	720

- \* Included heater
- \* Included temperature sensor
- \* Air Pressure:0.6MPa
- \* Working air hose inner diameter:4mm
- ※ 200V/240V heaters are also available to order.

### Blades Specifications

Material	Blade Shape	Blade Opening (mm)	Cutting blade effective (mm)	Weight (g)
Special Alloy Steel	Knife type (resin)	10	19	125

### Option Parts

- \*Hydro-converter(Recommended:KOGANEI AHC 32\*50)
- Working fluid: Petroleum hydraulic fluid or turbine oil with antifoaming agent additive(VG22~100)
- \*Temperature controller(DTC-001)

Profile, SUS Tube  
型材、钢管

Stents Module  
支架模组

Quick Changer  
快换

Grip Module  
夹具组件

Air Nipper  
气动剪刀

Vacuum Module  
真空组件

Accessory Components  
附件

# 加热剪刀

## GT-NKH10 Heat Air Nippers

# NKH

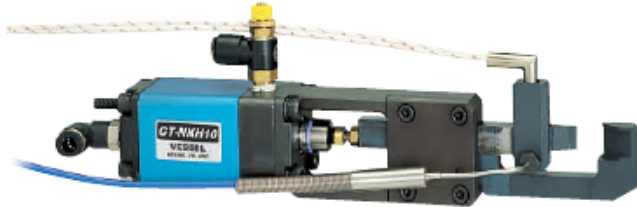

调整剪切速度和刀刃温度, 达到最佳剪切效果, 对于各种高精度剪切。

Speed control of cut speed and heater temperature allows for variable cutting surface solutions for extremely high precision cutting demands.

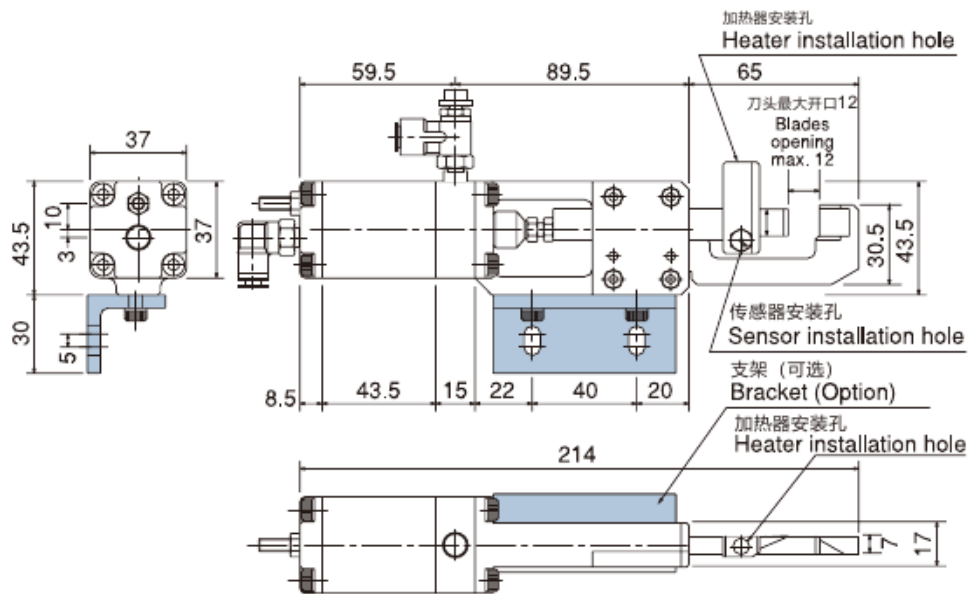

Model No.	Cutting Capacity ∅ (mm) Acrl	Blade Edge Temp. (MAX °C)	Cutting Cycle (sec/cut)	Air Consumption (cm <sup>3</sup> /str.)	Piston Stroke (mm)	Weight (g)
<b>GT-NKH10</b>	7x1.5	200	4~5	73	12	715

\* Included heater:80W/120V Cord length: 3000mm

\* Included temperature sensor:Thermal couple type K(Nickel-Chromubm/Nickel-Aluminum)

× Cord length:1000mm

• Air Pressure:0.5~0.6MPa

### Blades Specifications

Model No.	Material	Blade Shape	Blade Opening (mm)	Cutting Blade effective (mm)	Weight (g)
<b>NKH10AJ/NKH10RAJ</b>	Special Alloy Steel	Knife type (resin)	12	10	137

### Option Parts

\*Temperature controller(DTC-001)

Profile- SUS Tube  
型材、钢管

Stents Module  
支架模组

Quick Changer  
快换

Grip Module  
夹具组件

Air Nipper  
气动剪刀

Vacuum Module  
真空组件

Accessory Components  
附件

# 滑动式加热剪刀/刀头

GT-NTH05/10 Heat Air Nippers (Vertical Sliding Type)

Profile, SUS Tube  
型材、钢管

Stents Module  
支架模组

Quick Changer  
快换

Grip Module  
夹具组件

Air Nipper  
气动剪刀

Vacuum Module  
真空组件

Accessory Components  
附件

NTH



单边刀刃固定+本体滑动, 保证刀刃与浇口精确对齐。

One blade is fixed in position, facilitating easy gate alignment. In addition, a slide function presses the product into position.

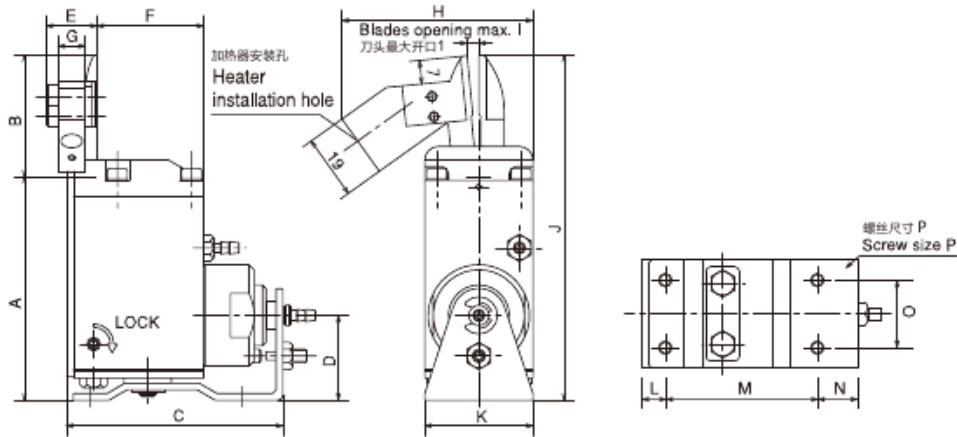

Model No.	Cutting Capacity φ (mm) Acrl	Blade Edge Temp. (MAX °C)	Cutting Cycle (sec/cut)	Air Consumption (cm <sup>3</sup> /str.)	Slide Distance (mm)	Weight (g)	Dimensions (mm)															
							A	B	C	D	E	F	G	H	I	J	K	L	M	N	O	P
GT-NTH05	2.5	200	4~5	47	0~3	325	66.1	36	64	25.1	15	31.5	8	56.5	3.5	102.1	32	7	45	12	20	M4
GT-NTH10	3.5	200	4~5	82	0~3	515	83	47	73	29	16.2	37.5	8	63	4.5	130	38	8	53	12	24	M4

- \* Included heater: 80W/120V Cord length:300mm
- \* Included temperature sensor: Thermal couple type K (Nickel-Chromium/Nickel-Aluminum)
- \* Air Pressure:0.4~0.5MPa

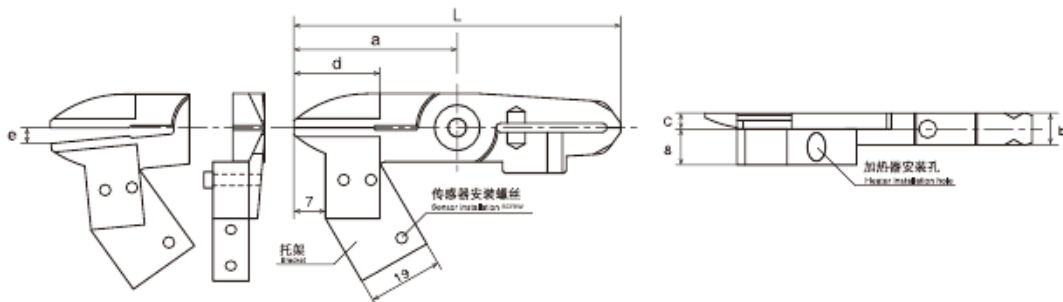

## Blades Specifications

Model No.	Material	a (mm)	b (mm)	c (mm)	d (mm)	e (mm)	L (mm)	Weight (g)	Cutting Capacity φ (mm) Acrl	Setting temp. (MAX °C)	Application model
NTH05AJ	Special Alloy Steel	36	7	3.5	15	3.5	72	40	2.5	200	GT-NT05(-4)/GT-NT05R(-4)
NTH10AJ	Special Alloy Steel	47	9	4.7	17	4.5	94	88	3.5	300	GT-NT10(-6)/GT-NT10R(-6)

HTH type blade weight does not include heater and sensor.

## Option Parts

- \* Temperature controller(DTC-001)

气动剪刀(剪切和压接)

## Air Nippers For Cutting and Crimping

高剪切力场合

剪切直径23mm至75mm尺寸范围内圆柱产品

此型号在切割和压接场合广泛使用

A tough body for hard jobs.

With a frame diameter range of 23mm to 75mm, this product line was developed by piston size.

These models are ideal for a broad spectrum of cutting and crimping work.



# 方型气动剪刀(自动化剪切用)

GT-NS3/5/7/10L/20/30 Square Air Nippers

# NS

刀头种类丰富,可对应各种树脂成型的浇口剪切,自动化焊接及线材卷线机的线切割。

VESSEL provides a generous selection of blades for all wire cutting needs, including resin product gate cuts and automatic welding equipment.



- 进气口的位置可以旋转180度。
- 提供两个进气口,因此可以根据安装位置进行自由切换。
- The main body end is 180° rotatable.
- Two suction(intake) ports are provided,and so the suction position can be optionally changed depending on the mounting place.

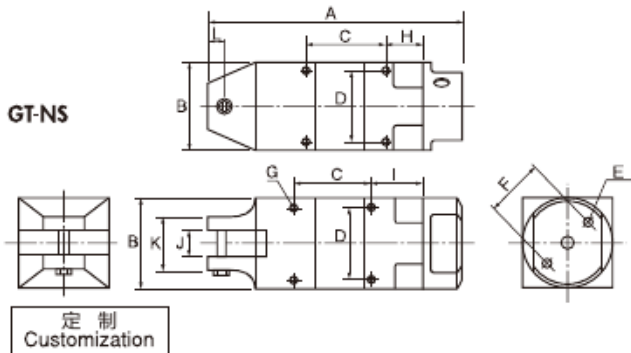

GT-NS20H-1 (刀头开口可调)(Blade opening adjustable)

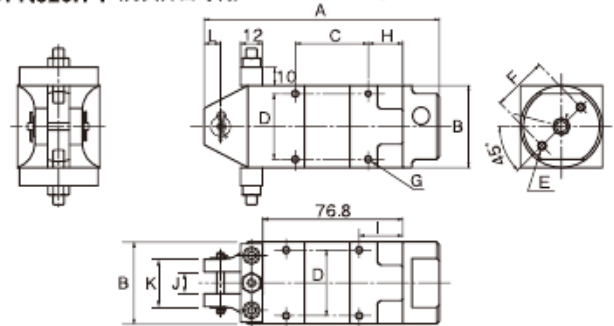

Capacity φ (mm)				Model No.	Size (mm)											Air Consumption (cm <sup>3</sup> /str.)	Air Pressure (MPa)	Weight (g)	Hose coupling	
Soft Plastic	Hard Plastic	Copper	Steel		A	B	C	D	E	F	G	H	I	J	K					L
2.0	1.0	0.5		GT-NS3	110	23	40	19	M3 Depth8	17	M3 Depth3.5	19	24	7	23	7	45	0.4~0.5	95	Rc1/8
2.0	1.0	0.5		GT-NS5	94	30	30	24	M4 Depth10	20	M3 Depth5	14	19	7	23	7	64	0.4~0.5	135	
3.0	2.0	1.6	1.0	GT-NS7	113	36	30	28	M4 Depth10	24	M4 Depth5.5	18	23	9	23	7	116	0.4~0.5	215	
4.0	2.6	1.8	1.2	GT-NS10L	113	36	30	28	M4 Depth10	24	M4 Depth5.5	18	23	12	26	7	116	0.4~0.6	215	
7.0	5.0	2.6	2.0	GT-NS20	129	45	40	36	M5 Depth12	30	M4 Depth7	19	24	12	26	9	230	0.5~0.6	370	
10.0	6.5	3.3	2.8	GT-NS30	170	56	60	46	M6 Depth12	40	M5 Depth10	20	30	17	36	15	584	0.5~0.6	685	
7.0	5.0	2.6	2.0	GT-NS20H-1	129	45	40	36	M5 Depth12	30	M4 Depth7	19	24	12	26	9	230	0.5~0.6	455	

\* Air hose inner dia:5mm\*Overall length/Weight:Accessories not included.

※Before mounting of exclusive/automatic machines,check the following product dimensions.

(Frame O.D.,screw dia.(screw to screw)dimensions,etc)

※Model GT-NS50 is a special order item.Please contact VESSEL for details.

Profile, SUS Tube  
型材、钢管

Stents Module  
支架模组

Quick Changer  
快换

Grip Module  
夹具组件

Air Nipper  
气动剪刀

Vacuum Module  
真空组件

Accessory Components  
附件

# 手持式气动剪刀(手动剪切用)

GT-N3/5/7/10/12/20/30/50 Hand Held Air Nippers

N

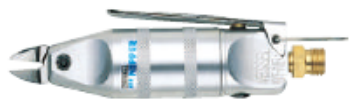

为满足生产工序的各种需求,可特殊定做刀头,提高生产效率,降低工人操作疲劳。

VESSEL's special order blades provide solutions for a virtually unlimited range of needs, leading to safer, and more efficient work with less fatigue.

- N20,N30 和N50有空气旋塞。
- N20,N30 and N50 have the air cock.

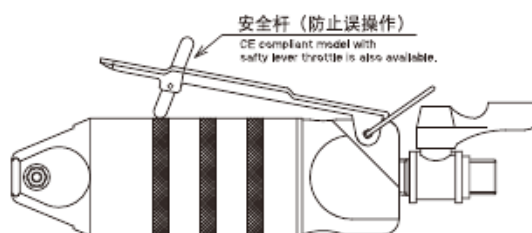
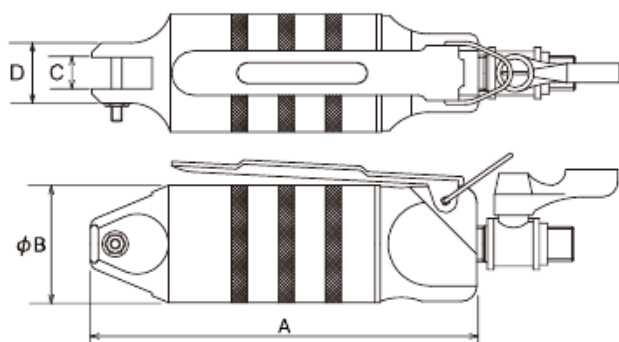

Capacity φ (mm)	Capacity φ (mm)			Model No.	Size (mm)				Air Consumption (cm <sup>3</sup> /str.)	Air Pressure (MPa)	Weight (g)	Body	Hose coupling
	Soft Plastic	Hard Plastic	Copper		A	B	C	D					
2.0		1.0	0.5	GT-N3	112	23	7	14	45	0.4~0.5	95	Rc1/8	R1/4
2.0		1.0	0.5	GT-N5	103	30	7	17	64	0.4~0.5	135	Rc1/8	
3.0	2.0	1.6	1.0	GT-N7	123	34	9	17	116	0.4~0.5	180	Rc1/4	
4.0	2.6	1.8	1.2	GT-N10	132	34	9	17	116	0.4~0.5	185	Rc1/4	
4.5	4.0	2.3	1.7	GT-N12	142	36	12	20	116	0.5~0.6	210	Rc1/4	
7.0	5.0	2.6	2.0	GT-N20	156	45	12	23	230	0.5~0.6	375	Rc1/4	
10.0	6.5	3.3	2.8	GT-N30	193	56	17	30	584	0.5~0.6	625	Rc1/4	
		5.5	4.5	GT-N50	237	75	25.2	43	1,170	0.5~0.6	1,220	Rc1/4	

\*Hose coupling:R1/4 \*Air hose inner dia:5mm \*Overall length:Accessories,Hunger not included. \*Weight: Accessories not included. Blade is optional.

Profile- SUS Tube  
型材、钢管

Stents Module  
支架模组

Quick Changer  
快换

Grip Module  
夹具组件

Air Nipper  
气动剪刀

Vacuum Module  
真空组件

Accessory Components  
附件

# 圆型气动剪刀(自动化剪切用)

GT-NR3/5/7/10L/20/30/50 Air Nipper Round-Type without Lever

# NR

Profile, SUS Tube  
型材、钢管

Stents Module  
支架模组

Quick Changer  
快换

Grip Module  
夹具组件

Air Nipper  
气动剪刀

Vacuum Module  
真空组件

Accessory Components  
附件



NR20本体两面含有位置安装刻度表。  
The Nr20 body contains the installation scale of two sides.

- 进气口位置可以旋转**180度**。
- 提供两个进气口, 因此可以根据安装位置进行切换。
- The main body end is 180° rotatable.
- Two suction (intake) ports are provided, the suction can be optionally changed depending on the mounting plate.

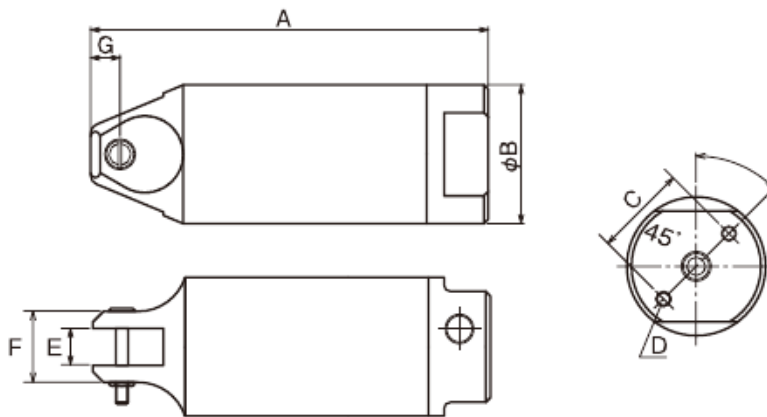

Soft Plastic	Hard Plastic	Copper	Steel	Model No.	A	B	C	Size (mm) D	E	F	G	Air Consumption (cm <sup>3</sup> /str.)	Air Pressure (MPa)	Weight (g)	Hose coupling
2.0		1.0	0.5	GT-NR3	110	23	17	M3 Depth8	7	14	7	45	0.4~0.5	70	Rc1/8
2.0		1.0	0.5	GT-NR5	94	30	20	M4 Depth10	7	17	7	64	0.4~0.5	110	
3.0	2.0	1.6	1.0	GT-NR7	113	34	22	M4 Depth10	9	17	7	116	0.4~0.5	150	
4.0	2.6	1.8	1.2	GT-NR10L	113	36	24	M4 Depth10	12	20	7	116	0.4~0.6	215	
7.0	5.0	2.6	2.0	GT-NR20	129	45	30	M5 Depth12	12	23	9.5	230	0.5~0.6	280	
10.0	6.5	3.3	2.8	GT-NR30	165	56	40	M6 Depth12	17	30	10.5	584	0.5~0.6	505	
12.0	6.5	5.5	4.5	GT-NR50	222	75	50	M8 Depth12	25.2	43	15	1,170	0.5~0.6	1,190	

\* Air hose inner dia:5mm \*Overall length/Weight : Accessories not included.  
Before mounting of exclusive/automatic machines, check the following product dimensions.  
(Frame O.D., screw dia.(screw to screw)dimensions, etc.)

## GT-NR 用固定架

GT-NR10LST/20ST/30ST/50ST Stand



安装在直浇道或自动机上的固定金属架。  
可以调整安装角度(0~60度)  
Stands for installing air nippers.  
The angle is easily adjustable.

Model No.	E	Size (mm)			Weight (g)
		F	G	H	
NR10LST	102	52	36	84	335
NR20ST	110	60	45	92	385
NR30ST	130	80	56	112	535
NR50ST <small>Option</small>	150	100	75	132	835

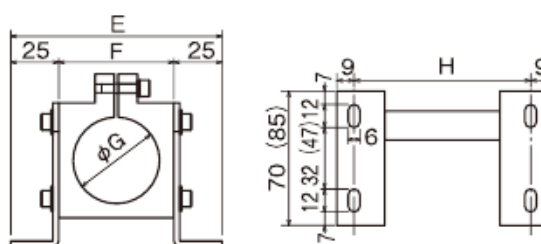

( ) 中的图是用于 NR50ST 的  
Figures in ( ) are for the NR50ST

安装实例  
Mounting example

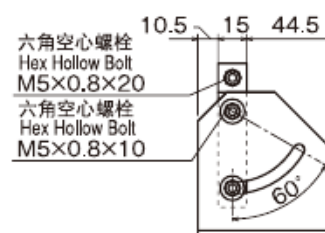
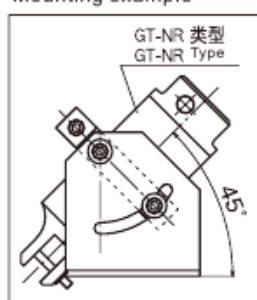

## 增压器

P-10L/20/30/50 Powerful Intensifiers(With Extra pressure Booster)

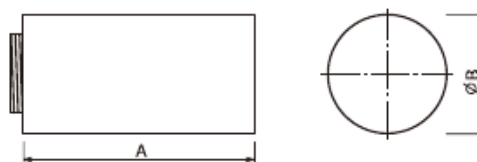

该设备可在因空间或空气压力受限得不到足够压力时使用。  
This unit is to be used in case the originally required pressure is not obtainable by the limit of space and air pressure.

Capacity $\phi$ (mm)	Application model				Model No.	Size (mm)		Air Consumption (cm <sup>3</sup> /str.)	Air Pressure	Weight (g)
	Soft Plastic	Hard Plastic	Copper	Steel		A	B			
5.0	4.0	2.6	1.6	NS10L, NR10L, N12	P-10L	71	36	223	Up to 0.5MPa	115
8.0	6.0	3.0	2.2	N20, NS20, NR20	P-20	87	45	508	Up to 0.5MPa	215
13.0	7.0	4.8	4.0	N30, NS30, NR30	P-30	92	56	956	Up to 0.5MPa	330
		6.5	5.5	NS0, NR50	P-50	133	75	2,670	Up to 0.5MPa	840

\*Above figures of overall length and the weight are defined for the extra booster specs only. And these figures in the installation.  
Blade is optional.

# 复动式气动剪刀

GT-NWR10/20/30 GT-NWS1/10/20/30 Double Action Air Nippers

# NWR·NWS



刀头的开合由空气活塞驱动。

本体内不含活塞复位弹簧，便于维护。

Blade opening and closing is air piston driven.

Having no spring mechanism in the main unit facilitates maintenance operations.

GT-NWR

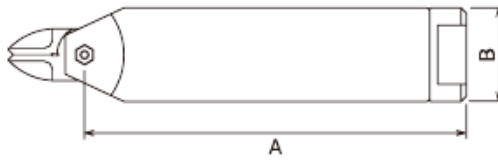

GT-NWS

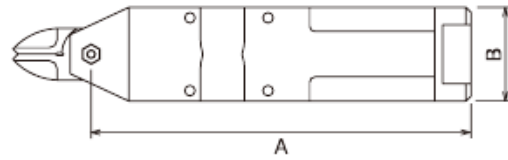

Model No.	Capacity $\phi$ (mm)			Air Consumption (cm <sup>3</sup> /str.)	Applied Force (N)	Air Pressure (MPa)	Size (mm)		Weight (g)
	Copper	Steel	ABS Plastic				A	B	
Double Action Air Scissors (Round Type without Lever)									
GT-NWR10	1.8	1.2	4.0	116	588	0.4~0.5	146	$\phi$ 36	280
GT-NWR20	2.6	2.0	6.5	230	1,372	0.5~0.6	165	$\phi$ 45	523
GT-NWR30	3.3	2.8	9.5	584	2,744	0.5~0.6	230.5	$\phi$ 56	980
Double Action Air Scissors (Square Type)									
GT-NWS1	1.0	0.5	2.0	45	294	0.4~0.5	95	23X20	116
GT-NWS10	1.8	1.2	4.0	116	588	0.4~0.5	146	36X36	356
GT-NWS20	2.6	2.0	6.5	230	1,372	0.5~0.6	165	45X45	610
GT-NWS30	3.3	2.8	9.5	584	2,744	0.5~0.6	230.5	56X56	1115

Profile, SUS Tube  
型材、钢管

Stents Module  
支架模组

Quick Changer  
快换

Grip Module  
夹具组件

Air Nipper  
气动剪刀

Vacuum Module  
真空组件

Accessory Components  
附件

# 滑动式气动剪刀支架

GT-NB20/30/20LW/30LW Slide-Off Air Nipper Bracket-Type

# NB



GT-NB20LW-10TM

滑动座高精度型  
Accurate slide function  
with slide stroke



GT-NB20

大型树脂产品剪切浇口时即使产生较大的冲击，本体也可以平稳的滑动，达到高精度剪切。  
VESSEL has achieved smooth, continuous slide movement even for large diameter gate cuts, which produce a large shock at each cut.

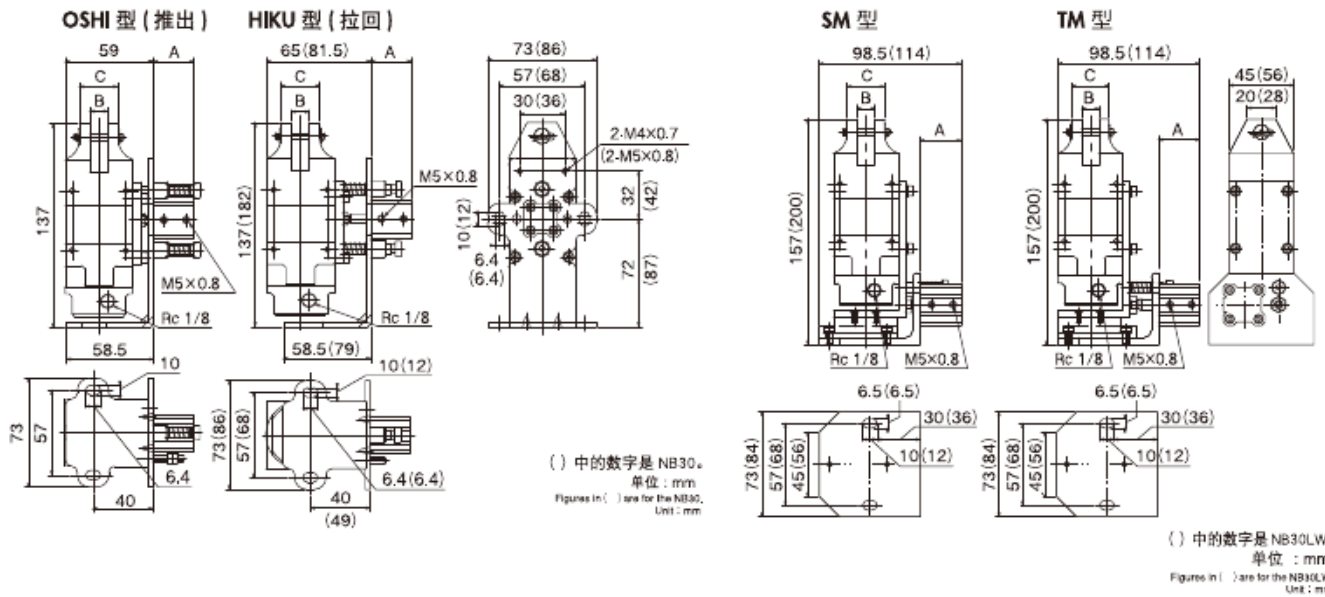

Model No.	Size (mm)			Slide Direction/ Distance (mm)	Weight (g)
	A	B	C		
GT-NB20 (5-OSHI)	22	12	26	Push 0~5	755
GT-NB20 (5-HIKU)	22	12	26	Pull 0~5	755
GT-NB20 (10-OSHI)	27	12	26	Push 0~10	755
GT-NB20 (10-HIKU)	27	12	26	Pull 0~10	755
GT-NB30 (10-HIKU)	28.5	17	36	Pull 0~10	1,420
GT-NB20LW-10TM	28.5	12	26	Pull 0~10	795
GT-NB30LW-10TM	29.5	17	36	Pull 0~10	1,315
GT-NB20LW-10SM	28.5	12	26	Push 0~10	795
GT-NB30LW-10SM	29.5	17	36	Push 0~10	1,325

Blade is optional

Profile- SUS Tube  
型材、钢管

Stents Module  
支架模组

Quick Changer  
快换

Grip Module  
夹具组件

Air Nipper  
气动剪刀

Vacuum Module  
真空组件

Accessory Components  
附件

# 标准刀头 树脂用

## Air Nipper Standard Blades For Plastic

Profile, SUS Tube  
型材、钢管

Stents Module  
支架模组

Quick Changer  
快换

Grip Module  
夹具组件

Air Nipper  
气动剪刀

Vacuum Module  
真空组件

Accessory Components  
附件

### AP



### 树脂用标准刀头(塑料)

Standard cutter head for resin(Plastic)

AP/树脂剪切用标准刀头。刀刃含有倾斜角度，确保剪切面无残留。

AP/ This is a standard set of blades used to cut plastic. A broad, gentle curve is provided in the cross section for gate processing where the cut end must not be left. (The cutting edge is curved.)

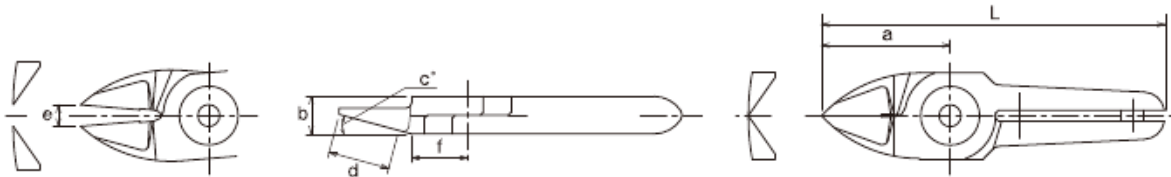

Model No.	Size (mm)							Weight (g)	Material	Application model
	a	b	c(°)	d	e	f	L			
N3AP	24	7	15	11.5	4	10.5	64	35	Special alloy steel	GT-N3 / NS3 / NR3
N5AP	24	7	15	11.5	4	10.5	64	40	Special alloy steel	GT-N5 / NS5 / NR5
N7AP	27	9	30	11.5	4	14.5	81	80	Special alloy steel	GT-N7 / NS7 / NR7
N10AP	27	9	30	11.5	5	14.5	91	85	Special alloy steel	GT-N10
N10LAP	35	12	15	16	5	15	89	120	Special alloy steel	GT-NS10L / NR10L
N12AP	35	12	15	16	5	15	105	135	Special alloy steel	GT-N12
N20AP	35	12	15	16	11	15	95	125	Special alloy steel	GT-NS20 / NR20 / N20 / NB20
N30AP	66	17	15	38	16	24	150	380	Special alloy steel	GT-NS30 / NR30 / N30 / NB30

### AE



### 树脂用剪钳刀头(塑料)

Nipping blades for plastic(Plastic)

AE/ 处理直接浇口和搭接浇口时有效

AE/ Used for processing plastic gates such as ride gates and discard gates.

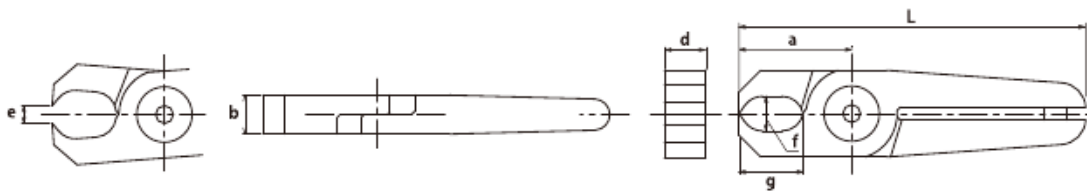

Model No.	Size (mm)					Weight (g)	Material	Application model	
	a	b	f×g	d	e				
N3AE	20	7	6×11	7	3.5	60	35	Special alloy steel	GT-N3 / NS3 / NR3
N5AE	20	7	6×6.6	7	3.5	60	40	Special alloy steel	GT-N5 / NS5 / NR5
N7AE	26	9	8×14.8	9	4	80	85	Special alloy steel	GT-N7 / NS7 / NR7
N20AE	28	12	10×15.5	12	8	88	135	Special alloy steel	GT-NS20 / NR20 / N20 / NB20
N30AE	45	17	13×28	17	12	129	395	Special alloy steel	GT-NS30 / NR30 / N30 / NB30

## 标准刀头 树脂用

### Air Nipper Standard Blades For Plastic

#### AJ



#### 树脂用直刀(塑料)

Thin, straight blades for plastic(Plastic)

AJ/ 树脂用直刀, 刀刃不含倾斜角, 可垂直剪切。

AJ/ This is a set of vertical blades with an unbeveled cutting edge for plastic. You can apply it at a right angle to the gate.

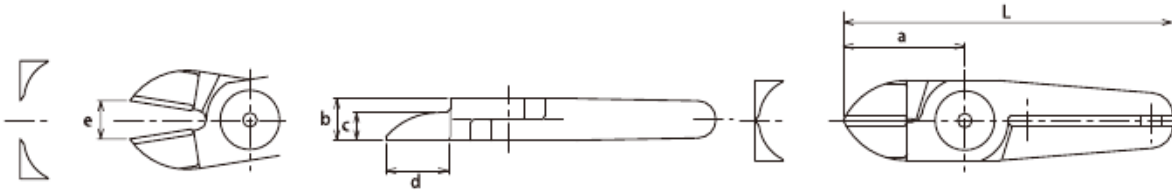

Model No.	a	b	Size (mm)			L	Weight (g)	Material	Application model
			c	d	e				
NW10AJ	30	9	6	14	5	85	76	Special alloy steel	GT-NWR10 / NWS10
N20AJ	35	12	8	18	11	95	125	Special alloy steel	GT-NS20 / NR20 / N20 / NB20
N20AJB	35	12	8	18	11	95	125	Sintered Alloy	GT-NS20 / NR20 / N20 / NB20
NW20AJ	40	12	6	21.5	8	100	142	Special alloy steel	GT-NWR20 / NWS20
N30AJ	52	17	8	28	11	136	370	Special alloy steel	GT-NS30 / NR30 / N30 / NB30
NW30AJ	55	17	8	29.5	11	140	368	Special alloy steel	GT-NWR30 / NWS30

#### AJL/Quasi-standard products



#### 树脂用直刀(塑料)

Straight long blades for plastic(Plastic)

AJL/AJ的刀刃加长型, 刀头与浇口距离较远时有效。

N30AJL163 用于剪切宽大浇口。

AJL/ This is a long type set of straight blades. This is suitable when there is distance between the nippers and the gate cut portion of the workpiece. N30AJL163 is useful for wide gate processing

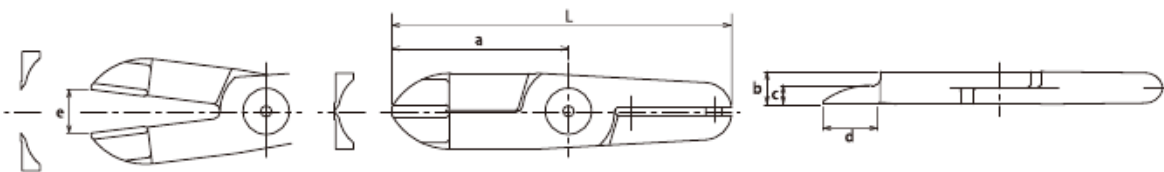

Model No.	a	b	Size (mm)			L	Weight (g)	Material	Application model
			c	d	e				
N10LAJ141	61	12	7	34	10	115	165	Special alloy steel	GT-NS10L / NR10L
N20AJL	65	12	7	20	16	125	230	Special alloy steel	GT-NS20 / NR20 / N20 / NB20
N20AB39	61	12	7	36	14	121	185	Special alloy steel	GT-NS20 / NR20 / N20 / NB20
N30AJ163	65	17	7	41	17.5	149	355	Special alloy steel	GT-NS30 / NR30 / N30 / NB30
N30AJL	75	17	8	25	19	159	470	Special alloy steel	GT-NS30 / NR30 / N30 / NB30

## 标准刀头树脂用

### Air Nipper Standard Blades For Plastic

#### PF



#### 树脂用平刀头(塑料)

Flat blades for plastic(Plastic)

PF /把塑料切割的切口平坦的塑料用刀头。  
不会在切割时在切断面留下很大的R型切口。

PF/ This is a set of blades for cutting the cut end fiat for plastic.  
A large is provided in the cross section for gate processing  
where the cut end must not be left.



Model No.	Size (mm)							Weight (g)	Material	Application model
	a	b	c (°)	d	e	f	L			
N7PF	27	9	40	10.5	4	17	81	80	Special alloy steel	GT-N7 / NS7 / NR7
N10LPF	35	12	40	13.5	5	21	89	120	Special alloy steel	GT-NS10L / NR10L
N20PF	35	12	40	13.5	11	21	95	130	Special alloy steel	GT-NS20 / NR20 / N20 / NB20
N30PF	58	17	30	25	15	33	142	390	Special alloy steel	GT-NS30 / NR30 / N30 / NB30

#### AH



#### 树脂用L型刀头(塑料)

Crank blades for plastic(Plastic)

AH/ 刀头前端成 L 型, 有障碍物或浇口狭窄时有效。

AH/ This is a set of blades with a crank cutting edge for plastic. It is effective when there are obstructions or the gate is narrow.

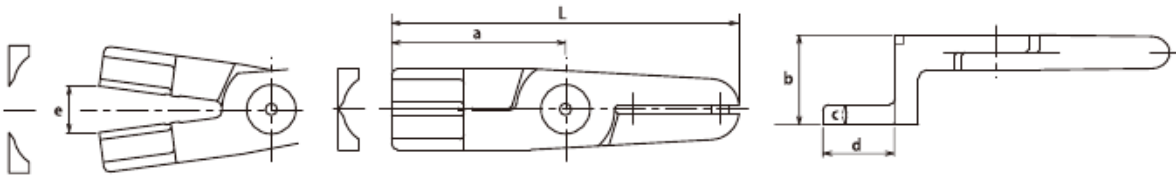

Model No.	Size (mm)						Weight (g)	Material	Application model
	a	b	c	d	e	L			
N20AH	60	31	7	23	16	120	240	Special alloy steel	GT-NS20 / NR20 / N20 / NB20

## 标准刀头树脂用

### Air Nipper Standard Blades For Plastic

#### AMR/AML



#### 树脂用横侧柄刀头(塑料)

Laterally facing blades for plastic(Plastic)

AMR/AML 刀头前端与刀柄成90度, 有障碍物或浇口狭窄时有效。

AMR/AML This is a set of blades for plastic where the ML cutting edge is bent 90 degrees. It is useful when restricted to confined spaces hard for the nipper to get into.

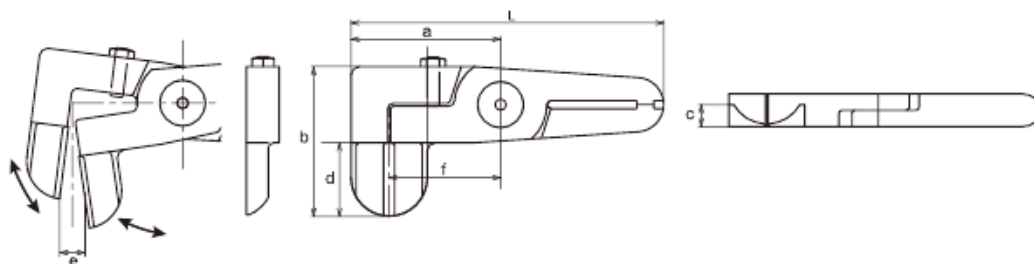

Model No.	Size (mm)			e	f	L	Weight (g)	Material	Application model	
	a	b	c							
N20AML1498	55	55	8	26	9.5	41	115	270	Special alloy steel	GT-NS20 / NR20 / N20 / NB20
N20AMR1499	55	55	8	26	9.5	41	115	270	Special alloy steel	GT-NS20 / NR20 / N20 / NB20
N30AML1435	55	68	10	35	13	39	139	520	Special alloy steel	GT-NS30 / NR30 / N30 / NB30
N30AMR1395	55	68	10	35	13	39	139	520	Special alloy steel	GT-NS30 / NR30 / N30 / NB30

#### Quasi-standard products



#### 树脂用R型刀头(刀刃有倾斜角)(塑料)

R blades for plastic(Plastic)

处理曲面浇口或剪切后必须无残留时有效。

刀刃含有倾斜角, 可根据本体安装角度选取最适刀头。

A large R is provided in the cross section for gate processing where the cut end must not be left. An angled blades can be selected in accordance with the installation angle of the main unit.

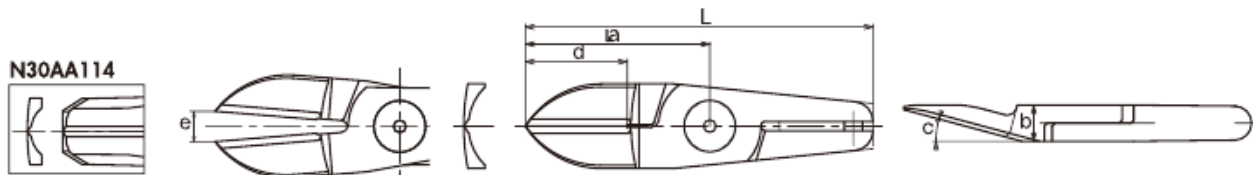

Model No.	Size (mm)			d	e	L	Weight (g)	Material	Application model
	a	b	c(°)						
N10LAB152	61	12	15	35	10	115	165	Special alloy steel	GT-NS10 / NR10L
N20AA27	45	12	23	25	12	105	145	Special alloy steel	GT-NS20 / NR20 / N20 / NB20
N20AA239	52.3	12	40	27	14	112.3	195	Special alloy steel	GT-NS20 / NR20 / N20 / NB20
N20AB360	61	12	15	35	16	121	185	Special alloy steel	GT-NS20 / NR20 / N20 / NB20
N30AA114	76.3	17	30	50	20	160.3	385	Special alloy steel	GT-NS30 / NR30 / N30 / NB30

## 标准刀头树脂用

### Air Nipper Standard Blades For Plastic

Profile, SUS Tube  
型材、钢管

Stents Module  
支架模组

Quick Changer  
快换

Grip Module  
夹具组件

Air Nipper  
气动剪刀

Vacuum Module  
真空组件

Accessory Components  
附件

### Quasi-standard products



#### 树脂用大L型刀头(塑料)

L blades for sprue cut (Plastic)

这是一个90度角的加长直角刀头。最适合切割直浇口。

This is an angled long type straight set of blades with a 90-degree angle. Ideal for direct gate cut.

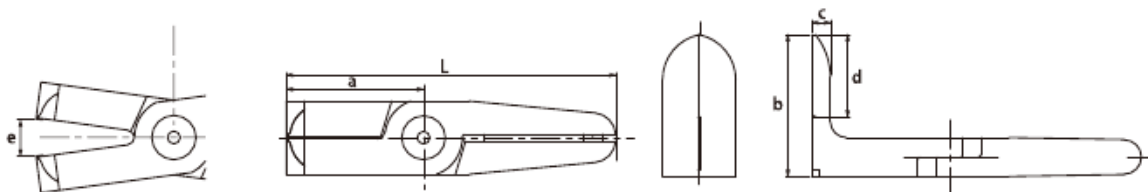

Model No.	Size (mm)						Weight (g)	Material	Application model
	a	b	c	d	e	L			
N30AL525	60	62	8	36	16	144	520	Special alloy steel	GT-N30 / NS30 / NR30 / NB30

### Quasi-standard products



#### 树脂用气动剪钳(塑料)

Nipping blades for plastic(Plastic)

AE/处理直接浇口和搭接浇口时有效。

AE/ Used for processing plastic gates such as ride gates, discard gates.

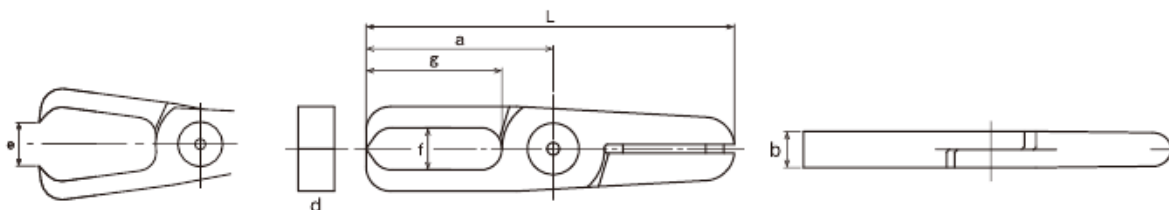

Model No.	Size (mm)						Weight (g)	Material	Application model
	a	b	f×g	d	e	L			
N20AE1205	62	12	14×45	12	16.5	122	202	Special alloy steel	GT-NS20 / NR20 / N20 / NB20

# 气动剪刀故障排除

## Air Nipper Troubleshooting

### 使用过程中发生故障时的检查项目

Inspection items when a malfunction occurs during use

现象 Symptoms	原因 Causes	处理措施 Treatment
刀刃或滑片无法正常工作 Blades or slide not working properly	气源未打开 Air is not being supplied	提供空气 Supply air
	软管打结 The hose is twisted	展开软管 Extend the hose
	气压低 Low air pressure	调整气压 Air pressure adjustment
	刀头移动轴生锈，腐蚀或混入异物 Corrosion, wear, or contamination of sliding part of the blades	润滑/拆卸调整 Lubrication/disassembly adjustment
	刀头移动轴烧灼(加热剪刀) Sliding parts burned by heat (heat nipper)	更换部件 Component replacement
	刀头弹簧损坏 Broken blade spring	更换部件 Component replacement
	气剪内部气缸复位弹簧损坏 Broken return spring	更换部件 Component replacement
	刀刃损坏 Broken blades	更换刀片 Replace blades
空气泄漏 Air leakage	刀头安装部位干涉 Wear of the cutting unit/rivet	更换刀片 Replace blades
	阀浇口功能不良/磨损, 损坏 (O形环, 球阀等) Valve malfunction/wear, damage (O-rings, ball valves, etc.)	更换部件 Component replacement
	外层包装 Packing is broken	更换部件 Component replacement

Profile- SUStube  
型材、钢管

Stents Module  
支架模组

Quick Changer  
快换

Grip Module  
夹具组件

Air Nipper  
气动剪刀

Vacuum Module  
真空组件

Accessory Components  
附件

# 气动剪刀本体

## NR20-P/NR30-P Air Nipper Round-Type without Lever

Profile, SUS Tube  
型材、钢管

Stents Module  
支架模组

Quick Changer  
快换

Grip Module  
夹具组件

Air Nipper  
气动剪刀

Vacuum Module  
真空组件

Accessory Components  
附件

# NR



- 进气口位置可以旋转180度。
- 提供两个进气口,可以根据安装位置进行自由切换。
- The main body end is 180° rotatable.
- Two suction (intake) ports are provided, the suction can be optionally changed depending on the mounting plate.

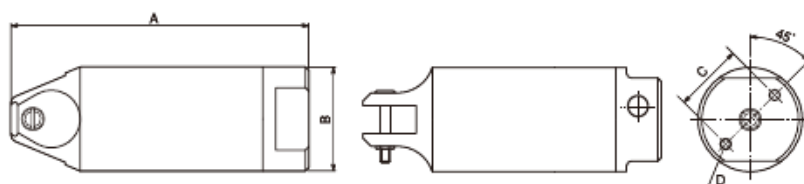

Soft Plastic	Hard Plastic	Copper	Steel	PN	Model No.	Size (mm)				Air Consumption (cm <sup>3</sup> /str.)	Air Pressure (MPa)	Weight (g)	Hose coupling
7.0	5.0	2.6	2.0	8.Y00113	NR20-P	A	B	C	D	230	0.5~0.6	280	Rc1/8
10.0	6.5	3.3	2.8	8.Y00237	NR30-P	129	45	30	M5 Depth12	584	0.5~0.6	505	

· Air hose inner dia:5mm  
 · Overall length/Weight:Accessories not included.  
 Before mounting of exclusive/automatic machines,check the following product dimensions.  
 (Frame O.D., screw dia.(screw to screw)dimensions,etc.)

# NR



- 进气口位置可以旋转180度。
- 提供两个进气口,可以根据安装位置进行自由切换。
- The main body end is 180° rotatable.
- Two suction (intake) ports are provided, the suction can be optionally changed depending on the mounting plate.

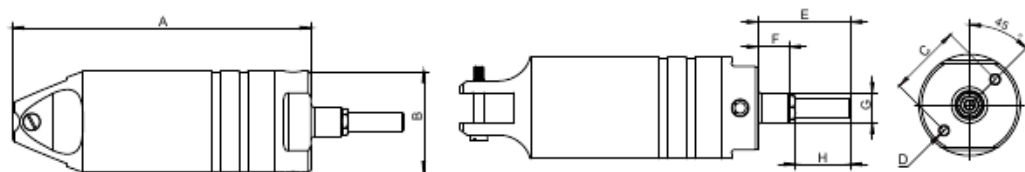

Soft Plastic	Hard Plastic	Copper	Steel	PN	Model No.	Size (mm)								Air Consumption (cm <sup>3</sup> /str.)	Air Pressure (MPa)	Weight (g)	Hose coupling	
7.0	5.0	2.6	2.0	8.Y00113-D1	NR20-P-D1	A	B	C	D	E	F	G	H	行程20mm	230	0.5~0.6	508	Rc1/8
10.0	6.5	3.3	2.8	8.Y00237-D1	NR30-P-D1	129	45	30	M5 Depth12	46	17	15	行程20mm	584	0.5~0.6	533		

· Air hose inner dia:5mm  
 · Overall length/Weight:Accessories not included.  
 Before mounting of exclusive/automatic machines,check the following product dimensions.  
 (Frame O.D., screw dia.(screw to screw)dimensions,etc.)

# 气动剪刀本体

## NR20-P/NR30-P Air Nipper Round-Type without Lever

NR



- 进气口位置可以旋转180度。
- 提供两个进气口,可以根据安装位置进行自由切换。
- 增加磁感应器,检测剪刀动作。
- The main body end is 180° rotatable.
- Two suction (intake) ports are provided, the suction can be optionally changed depending on the mounting plate.
- Add a magnetic sensor to detect nipper movement.

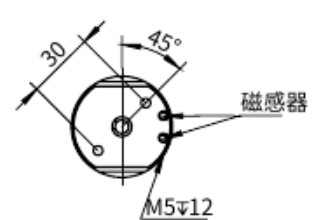
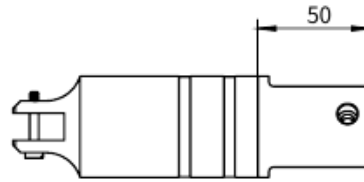
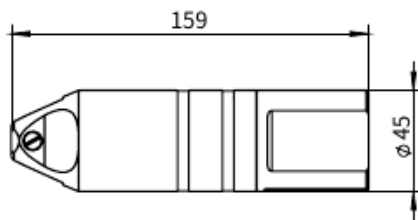

Soft Plastic	Hard Plastic	Copper	Steel	PN	Model No.	A	B	Size (mm)		Air Consumption (cm <sup>3</sup> /str.)	Air Pressure (MPa)	Weight (g)	Hose coupling
7.0	5.0	2.6	2.0	8.Y00454	NR20-P-S	159	45	30	M5 Depth12	230	0.5~0.6	280	Rc1/8

• Air hose inner dia:5mm  
 • Overall length/Weight:Accessories not included.  
 Before mounting of exclusive/automatic machines,check the following product dimensions.  
 (Frame O.D., screw dia.(scrwe to screw)dimensions,etc.)

Profile、SUSTube  
型材、钢管

Stents Module  
支架模组

Quick Changer  
快换

Grip Module  
夹具组件

Air Nipper  
气动剪刀

Vacuum Module  
真空组件

Accessory Components  
附件

# 气动加热剪刀

## GT-NS30-N30PF\_H Heat Air Nipper

Profile, SUS Tube  
型材、钢管

Stents Module  
支架模组

Quick Changer  
快换

Grip Module  
夹具组件

Air Nipper  
气动剪刀

Vacuum Module  
真空组件

Accessory Components  
附件

本产品适用于剪切一些透明产品时，  
可以有效的抑制裂纹，使切割面更加美观  
搭配产品温度控制器使用，推荐使用温度为 0-140° C  
最大开合距离为 15mm

优点:

1. 增加了隔热垫，最大可能的降低产品本身的温度
2. 加热棒与温控线等可与其他产品通用
3. 外观简洁

This product is suitable for cutting some transparent products,  
which can effectively suppress cracks and make the cutting surface more beautiful  
Recommended temperature 0-140° C for use with product temperature controller.  
Maximum opening distance 15mm

Advantages:

- 1.the increase of heat insulation pad, the maximum possible reduction of the temperature of the product itself
- 2.the heating rod and temperature control line can be used with other products
- 3.Simple appearance

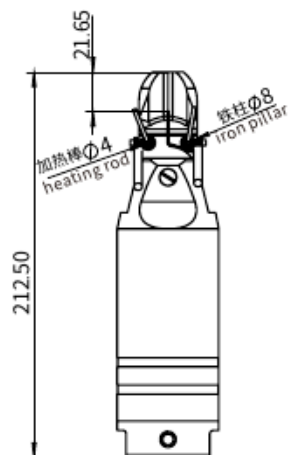
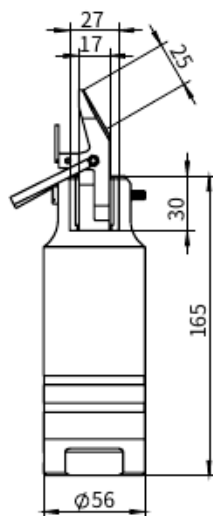

货号(PN)

型号(Model)

7.Y02260

GT-NR30-N30PF\_H

# 气动剪刀本体

NR20-P/NR30-P Square Air Nipper

NS



- 进气口位置可以旋转180度。
- 提供两个进气口,可以根据安装位置进行自由切换。
- The main body end is 180° rotatable.
- Two suction (intake) ports are provided, the suction can be optionally changed depending on the mounting plate.

刀头种类丰富,可对应各种树脂成型的浇口剪切,自动化焊接及线材卷线机的线切割。

VESSEL provides a generous selection of blades for all wire cutting needs, including resin product gate cuts and automatic welding equipment.

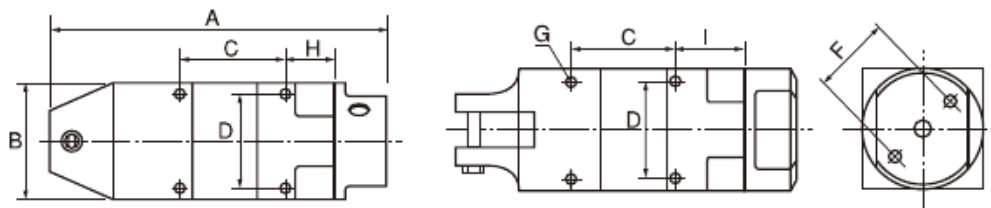

Capacity φ (mm)				PN	Model No.	Size (mm)						Air Consumption (cm <sup>3</sup> /str.)	Air Pressure (MPa)	Weight (g)	Hose coupling		
Soft Plastic	Hard Plastic	Copper	Steel			A	B	C	D	F	G					H	I
7.0	5.0	2.6	2.0	8.Y00079	NS20-P	129	45	40	36	30	M4Depth7	19	24	230	0.5~0.6	370	Rc1/8
10.0	6.5	3.3	2.8	8.Y00080	NS30-P	170	56	60	46	40	M5Depth10	20	30	584	0.5~0.6	685	

- Air hose inner dia.:5mm
- Overall length/Weight:Accessories not included.
- Before mounting of exclusive/automatic machines,check the following product dimensions. (Frame O.D., screw dia.(scrwe to screw)dimensions,etc.)
- Model GT-NS50 is a special order item.Please contact VESSEL for details

Profile- SUS Tube  
型材、钢管

Stents Module  
支架模组

Quick Changer  
快换

Grip Module  
夹具组件

Air Nipper  
气动剪刀

Vacuum Module  
真空组件

Accessory Components  
附件

## 气动剪刀本体

### NR20-P-D1 Square Air Nipper

进气口位置可以选择180度。  
提供两个进气口,可以根据安装位置进行自由切换。  
刀头种类丰富,可对应各种树脂成型的浇口剪切,  
自动化焊接及线材卷线机的线切割。

The inlet position can be adjusted by 180 degrees.  
Features two inlet ports that can be freely switched depending on the installation position.  
With a wide variety of cutting heads available, these tools are suitable for gate shearing in various resin molding processes, automated welding, and wire cutting in wire coiling machines.

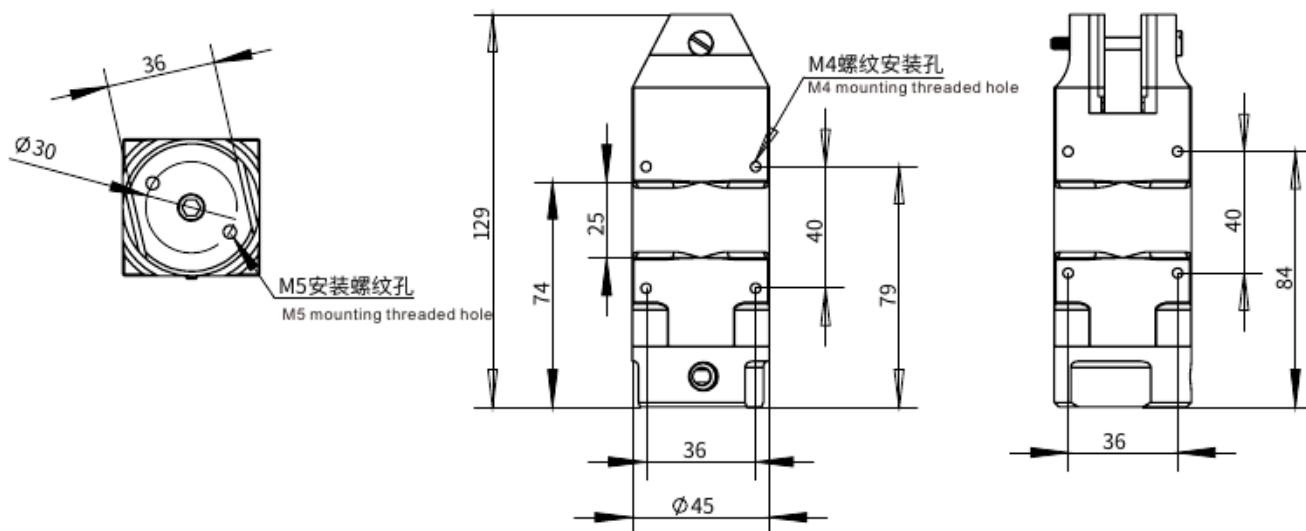
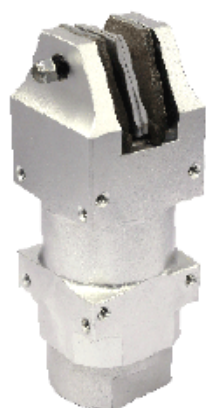

货号(PN)	型号(Model)	重量(weight)
7.Y03872	NS20-P-D1	395g

Profile、SUS Tube  
型材、钢管

Stents Module  
支架模组

Quick Changer  
快换

Grip Module  
夹具组件

Air Nipper  
气动剪刀

Vacuum Module  
真空组件

Accessory Components  
附件

## 气动剪刀本体 Square Air Nipper

NEW

50缸径, 适配30系列刀头。  
提供两个进气口, 可以根据安装位置进行自由切换。  
刀头种类丰富, 可对应各种树脂成型的浇口剪切,  
自动化焊接及线材卷线机的线切割。

50 mm bore diameter, compatible with 30-series cutting heads.  
Features two inlet ports that can be freely switched depending on the installation position.  
With a wide variety of cutting heads available, these tools are suitable for gate shearing in various resin molding processes, automated welding, and wire cutting in wire coiling machines.

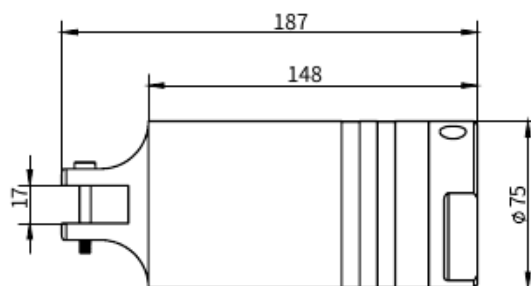
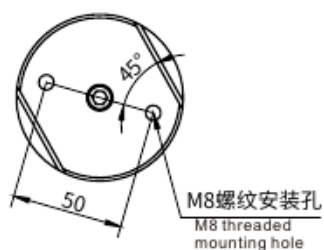

货号(PN)	型号(Model)	重量(weight)
8.Y01388	GT-NR50-30	1026g

Profile- SUS Tube  
型材、钢管

Stents Module  
支架模组

Quick Changer  
快换

Grip Module  
夹具组件

Air Nipper  
气动剪刀

Vacuum Module  
真空组件

Accessory Components  
附件

# 气动剪刀增压缸 NEW

## Pneumatic Scissor-Type Boosting Cylinder

串联气缸, 压力不足时,  
有限空间内提供更充足的空气压力。  
提供两个进气口,  
可以根据安装位置进行自由切换。

When using cylinders in series and air pressure is insufficient,  
provides sufficient air pressure in confined spaces.  
Features two air inlets,  
allowing for flexible switching based on the installation location.

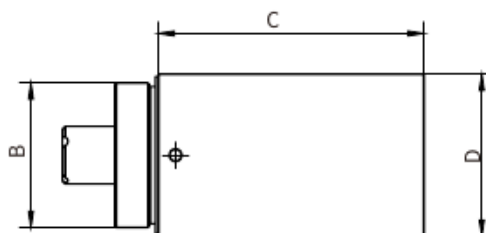
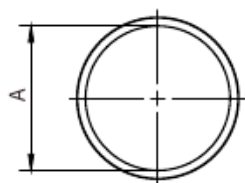

货号(PN)	型号(Model)	A	B	C	φD	重量(weight)
7.Y02001	T-20	M40x1.0	M40x1.0	87	45	213g
7.Y02002	T-30	M50x1.0	M50x1.0	92	56	322g

Profile、SUS Tube  
型材、钢管

Stents Module  
支架模组

Quick Changer  
快换

Grip Module  
夹具组件

Air Nipper  
气动剪刀

Vacuum Module  
真空组件

Accessory Components  
附件

# 引拔座

## Slide-Off Air Nipper Bracket-Type

产品剪切浇口时即使产生较大的冲击，本体也可以平稳的滑动，达到高精度剪切。

It has achieved smooth, continuous slide movement even for large diameter gate cuts, which produce a large shock at each cut.

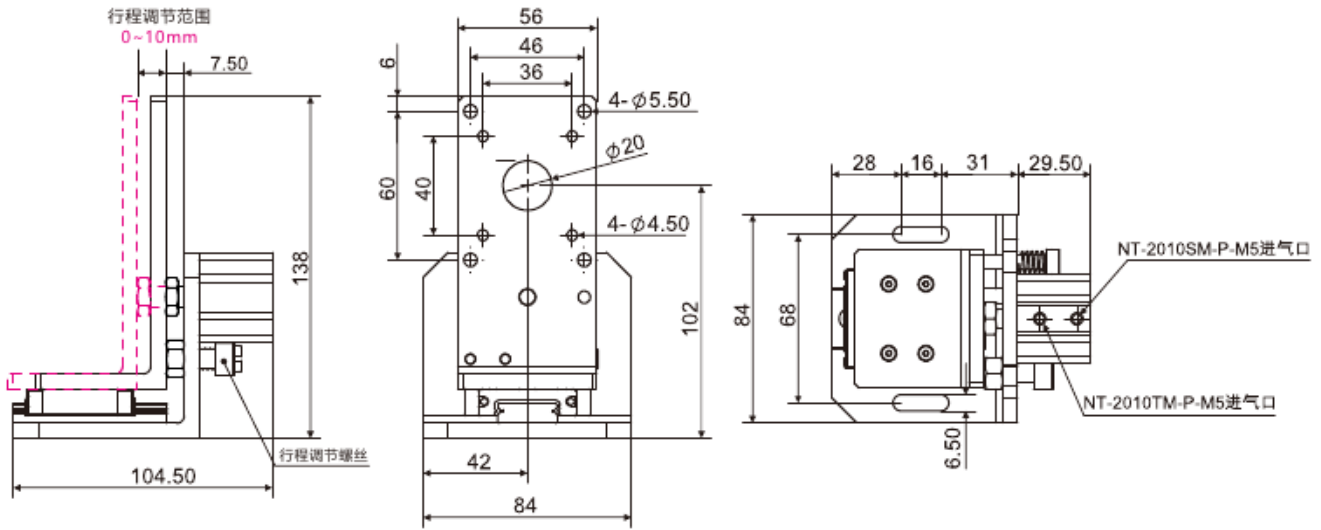

货号(PN)	8.Y00006	8.Y00003
型号(Model)	NT-2010TM-P	NT-2010SM-P
	通气拉回 pull by compressed air	通气推出 push by compressed air
重量(Weight)	612g	617.3g

Profile- SUS Tube  
型材、钢管

Stents Module  
支架模组

Quick Changer  
快换

Grip Module  
夹具组件

Air Nipper  
气动剪刀

Vacuum Module  
真空组件

Accessory Components  
附件

# 真空吸盘

## Vacuum Cups

Profile, SUS Tube  
型材、钢管

Stents Module  
支架模组

Quick Changer  
快换

Grip Module  
夹具组件

Air Nipper  
气动剪刀

Vacuum Module  
真空组件

Accessory Components  
附件

### 亮点

#### Highlights

- 尺寸和材质多种规格可选
  - 密封唇柔软且有锥度
  - 吸盘顶部有加强筋结构
  - 最优结构设计
  - 底部支撑结构
- Various sizes and materials are available  
Soft and tapered sealing lip  
Rib structure on the top of the suction cup  
Optimum structural design  
Bottom support structure

### 优势

#### Advantage

- 适合不同尺寸和形状的工作件
  - 对曲面和不平整的工作件有很强的适应性
  - 高速运动时, 具有极强的水平和横向抓取力
  - 尺寸小、吸力大
  - 搬运薄壁工件不会产生永久变形
- Suitable for workpieces of different sizes and shapes  
Strong adaptability to curved surfaces and uneven workpieces  
Strong horizontal and lateral grabbing force when moving at high speed  
Small size and high suction  
Handling thin-walled workpieces without permanent deformation

### 型号表示方法

#### Model representation methods

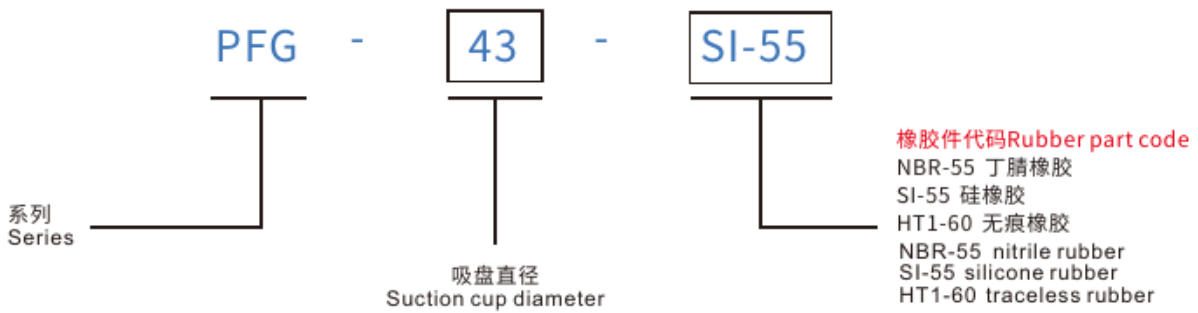

HT1-60 无痕橡胶



NBR-55 丁腈橡胶



SI-55 硅橡胶



包装行业  
Packaging industry



电子行业  
Electronics industry



注塑行业  
Injection molding industry

# 吸盘PFG系列(扁平式)

## Vacuum Cups PFG Series



HT1-60  
(蓝色)



NBR-55  
(黑色)



SI-55  
(透明)

PFG-2...PFG-10

PFG-15...PFG-50

PFG-60...PFG-95

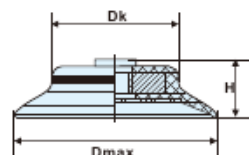
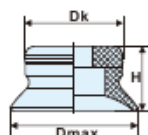
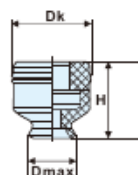

型号 (Model)	吸力 (N) <sup>(1)</sup>	推荐真空管 内径(mm)	Dk (mm)	Dmax (mm)	H (mm)	NBR-55 (黑色)	SI-55 (透明)	HT1-60 (蓝色)	重量 (Weight)
PFG-2-...	0.12	2	4.2	3.0	4.0	1.Y12953	1.Y12972	1.Y12991	0.02g
PFG-3.5-...	0.42	2	4.2	4.0	4.0	1.Y12954	1.Y12973	1.Y12992	0.03g
PFG-5-...	0.75	2	7.7	5.5	6.5	1.Y12955	1.Y12974	1.Y12993	0.15g
PFG-6-...	1.2	2	7.7	6.5	6.5	1.Y12956	1.Y12975	1.Y12994	0.17g
PFG-8-...	2.3	2	8.2	9.0	7.0	1.Y12957	1.Y12976	1.Y12995	0.23g
PFG-10-...	4.0	2	8.7	11.5	7.5	1.Y12958	1.Y12977	1.Y12996	0.30g
PFG-15-...	9.0	4	12.2	17.5	8.0	1.Y12959	1.Y12978	1.Y12997	1g
PFG-20-...	15.5	4	15.2	23.0	10.0	1.Y12960	1.Y12979	1.Y12998	1g
PFG-25-...	26.5	4	16.2	27.5	14.0	1.Y12961	1.Y12980	1.Y12999	3g
PFG-30-...	34.0	4	15.1	31.5	12.0	1.Y12962	1.Y12981	1.Y13000	3g
PFG-35-...	44.0	4	20.5	38.0	14.0	1.Y12963	1.Y12982	1.Y13001	6g
PFG-40-...	57.7	4	24.3	43.0	14.0	1.Y12964	1.Y12983	1.Y13002	7g
PFG-50-...	91.0	4	29.1	53.5	15.0	1.Y12965	1.Y12984	1.Y13003	11g
PFG-60-...	125	6	38.7	64.0	18.0	1.Y12966	1.Y12985	1.Y13004	25g
PFG-80-...	260	6	52.3	86.0	20.5	1.Y12967	1.Y12986	1.Y13005	52g
PFG-95-...	350	6	68.2	102.0	19.0	1.Y12968	1.Y12987	1.Y13006	93g

(1)上述规定吸力为在真空度为-0.6bar时的理论值,对于表面光滑、干燥的工件而言,未包括安全系数。

(1) The suction specified above is the theoretical value when the vacuum degree is -0.6bar. For smooth and dry workpieces, the safety factor is not included.

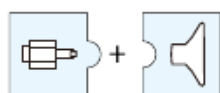

直插式  
Factory-crimped fitting

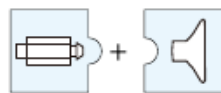

直插式  
Hollow shaft fitting

吸盘座 Vacuum Cup Fitting	吸盘 Vacuum Cups
VM14-M5	PFG-2~PFG-3.5
VM29-M5, VM30-G18	PFG-5~PFG-10
VM31-M5, VM32-G18	PFG-15
VM33-M5, VM34-G18	PFG-20
VM35-M5, VM36-G18	PFG-25~PFG-40
VM37-M5, VM38-G18	PFG-50
VM-G14M-M10M, VM-G18M-M10M	PFG-60~PFG-95

Materials 材质	Shore Hardness 硬度	A Flexibility 柔性	Abrasion resistance 耐磨性	UV & weather resistance 抗紫外线	Oil resistance 抗油污性	Heat resistance (in °C) 耐高温	
SI-55: Translucent Silicone 半透明硅胶	50	+++	-	-	-	-40 to 220	Translucent 半透明
HT1-60: Siton 特制复合材料(无痕)	60	+	++	-	++	-25 to 170	Blue 蓝色
NBR-55: Nitrile 丁腈橡胶	60	+	+	-	++	-30 to 120	Black 黑色

Profile-  
SUS Tube  
型材、钢管

Stents Module  
支架模组

Quick Changer  
快换

Grip Module  
夹具组件

Air Nipper  
气动剪刀

Vacuum Module  
真空组件

Accessory Components  
附件

# 吸盘FGA系列(波纹管式/2层)

## Vacuum Cups FGA Series

Profile, SUS Tube  
型材、钢管

Stents Module  
支架模组

Quick Changer  
快换

Grip Module  
夹具组件

Air Nipper  
气动剪刀

Vacuum Module  
真空组件

Accessory Components  
附件



SI-55  
(透明)



HT1-60  
(蓝色)



NBR-55  
(黑色)

FGA-6...FGA-25

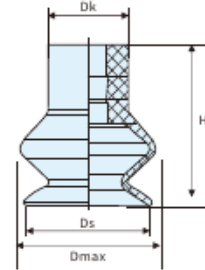

FGA-33...FGA-78

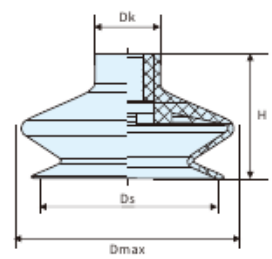

型号 (Model)	吸力 (N) <sup>(1)</sup>	拉脱力 (N) <sup>(1)(2)</sup>	推荐真空管 内径(mm)	Dk (mm)	Dmax(S) (mm)	Ds (mm)	H (mm)	NBR-55 (黑色)	SI-55 (透明)	HT1-60 (蓝色)	重量 (Weight)
FGA-6-...	0.4	1.4	4	7	8.0	5.7	9	1.Y12937	1.Y12949	1.Y12951	1g
FGA-11-...	0.95	3.8	4	10	13.0	10.4	16.0	1.Y12938	1.Y12288	1.Y12298	1g
FGA-14-...	1.2	5.0	4	10	14.5	12.5	15.5	1.Y12939	1.Y12289	1.Y12299	1g
FGA-16-...	2.3	6.7	4	10	18.5	15.6	19.2	1.Y12940	1.Y12290	1.Y12300	1g
FGA-20-...	4.7	10.7	4	10	21.0	18.1	15.2	1.Y12941	1.Y12291	1.Y12301	2g
FGA-22-...	5.7	15.2	4	10	25.0	21.5	19.0	1.Y12942	1.Y12292	1.Y12302	2g
FGA-25-...	5.3	17.3	4	10	26.5	22.5	23.0	1.Y12943	1.Y12293	1.Y12303	3g
FGA-33-...	13.6	39.6	6	18	38.0	30.0	27.0	1.Y12944	1.Y12294	1.Y12304	7g
FGA-43-...	22.8	64.5	6	18	47.5	38.0	27.6	1.Y12945	1.Y12295	1.Y12305	11g
FGA-53-...	51.3	95	6	18	60.0	50.0	34.0	1.Y12946	1.Y12296	1.Y12306	19g
FGA-63-...	85.0	135	6	18	68.0	60.0	34.0	1.Y12947	1.Y12297	1.Y12307	24g
FGA-78-...	137.4	218	6	25	84.5	74.0	47.0	1.Y12948	1.Y12950	1.Y12952	56g

(1)上述规定吸力为在真空度为-0.6bar时的理论值,对于表面光滑、干燥的工件而言,未包括安全系数

(1) The suction specified above is the theoretical value when the vacuum degree is -0.6bar. For smooth and dry workpieces, the safety factor is not included.

(2)天然橡胶材质的吸盘,其拉脱力约降低40%。

(2) The pull-off force of the vacuum cup made of natural rubber is reduced by about 40%.

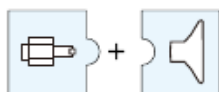

直插式  
Factory-crimped fitting

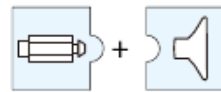

直插式  
Hollow shaft fitting

吸盘座 Vacuum Cup Fitting	吸盘 Vacuum Cups
VM21-M5	FGA-6
VM18-M5, VM02-G18	FGA-11~FGA-25
VM24-G18, VM42-G14	FGA-33~FGA-63
VM41-G14	FGA-78

Materials 材质	Shore Hardness 硬度	A Flexibility 柔韧性	Abrasion resistance 耐磨性	UV & weather resistance 抗紫外线	Oil resistance 抗油污性	Heat resistance (in °C) 耐高温	
SI-55: Translucent Silicone 半透明硅胶	50	+++	-	-	-	-40 to 220	Translucent 半透明
HT1-60: Siton 特制复合材料(无痕)	60	+	++	-	++	-25 to 170	Blue 蓝色
NBR-55: Nitrile 丁腈橡胶	60	+	+	-	++	-30 to 120	Black 黑色

# 吸盘FG系列(波纹管式/3层)

## Vacuum Cups FG Series

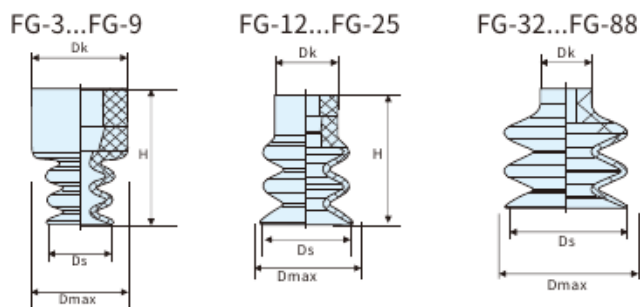

型号 (Model)	吸力 (N) <sup>(1)</sup>	拉脱力 (N) <sup>(1)(2)</sup>	推荐真空管 内径(mm)	Dk (mm)	Dmax(S) (mm)	Ds (mm)	H (mm)	NBR-55 (黑色)	SI-55 (透明)	HT1-60 (蓝色)	重量 (Weight)
FG-3-...	0.2	0.4	2	4	4.0	3.0	6.7	1.Y12929	1.Y12931	1.Y12934	1g
FG-4-...	0.3	0.6	2	7	7.0	3.8	14	1.Y12930	1.Y12932	1.Y12935	1g
FG-5-...	0.2	0.8	2	7	7.0	5.0	14	1.Y12308	1.Y12319	1.Y12331	1g
FG-7-...	0.1	0.9	4	9	9.0	5.9	14	1.Y12309	1.Y12320	1.Y12332	1g
FG-9-...	0.7	2.3	4	9	9.5	9.0	15	1.Y12310	1.Y12321	1.Y12333	1g
FG-12-...	0.9	3.5	4	10	13.0	12.0	21.0	1.Y12311	1.Y12322	1.Y12334	1g
FG-14-...	1.2	5.7	4	10	15.5	14.5	22.8	1.Y12312	1.Y12323	1.Y12335	2g
FG-18-...	2.3	8.5	4	10	19.0	17.2	22.6	1.Y12313	1.Y12324	1.Y12336	2g
FG-20-...	3.8	12.1	4	10	21.0	20.0	22.1	1.Y12314	1.Y12325	1.Y12337	2g
FG-25-...	4.5	19.0	4	10	26.0	23.0	34.0	1.Y12315	1.Y12326	1.Y12338	4g
FG-32-...	12.0	36.9	6	18	33.5	32	37.5	1.Y12284	1.Y12327	1.Y11797	10g
FG-42-...	13.6	44	6	18	45	42.6	46	1.Y12316	1.Y12328	1.Y12340	18g
FG-52-...	27.0	96	6	18	55	52.5	48.7	1.Y12317	1.Y12329	1.Y12341	24g
FG-62-...	39.6	137	6	18	65	62.2	54	1.Y12318	1.Y12330	1.Y12342	39g
FG-88-...	45.2	286	9	25	95.5	89	86.5	1.Y12928	1.Y12933	1.Y12936	166g

(1)上述规定吸力为在真空度为-0.6bar时的理论值,对于表面光滑、干燥的工件而言,未包括安全系数

(1) The suction specified above is the theoretical value when the vacuum degree is -0.6bar. For smooth and dry workpieces, the safety factor is not included.

(2)天然橡胶材质的吸盘,其拉脱力约降低40%。

(2) The pull-off force of the vacuum cup made of natural rubber is reduced by about 40%.

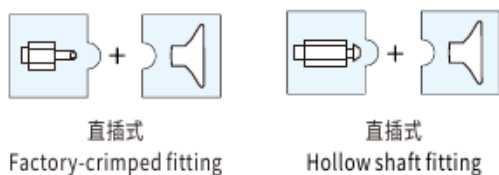

吸盘座 Vacuum Cup Fitting	吸盘 Vacuum Cups
VM14-M5	FG-3
VM21-M5	FG-4~FG-5
VM39-M5, VM40-G18	FG-7~FG-25
VM24-G18, VM42-G14	FG-32~FG-62
VM41-G14	FG-88

Materials 材质	Shore Hardness 硬度	A Flexibility 柔韧性	Abrasion resistance 耐磨性	UV & weather resistance 抗紫外线	Oil resistance 抗油污性	Heat resistance (in °C) 耐高温	
SI-55: Translucent Silicone 半透明硅胶	50	+++	-	-	-	-40 to 220	Translucent 半透明
HT1-60: Siton 特制复合材料(无痕)	60	+	++	-	++	-25 to 170	Blue 蓝色
NBR-55: Nitrile 丁腈橡胶	60	+	+	-	++	-30 to 120	Black 黑色

Profile- SUS Tube  
型材、钢管

Stents Module  
支架模组

Quick Changer  
快换

Grip Module  
夹具组件

Air Nipper  
气动剪刀

Vacuum Module  
真空组件

Accessory Components  
附件

# 吸盘PFYN系列(扁平式)

## Vacuum Cups PFYN Series

Profile, SUS Tube  
型材、钢管

Stents Module  
支架模组

Quick Changer  
快换

Grip Module  
夹具组件

Air Nipper  
气动剪刀

Vacuum Module  
真空组件

Accessory Components  
附件

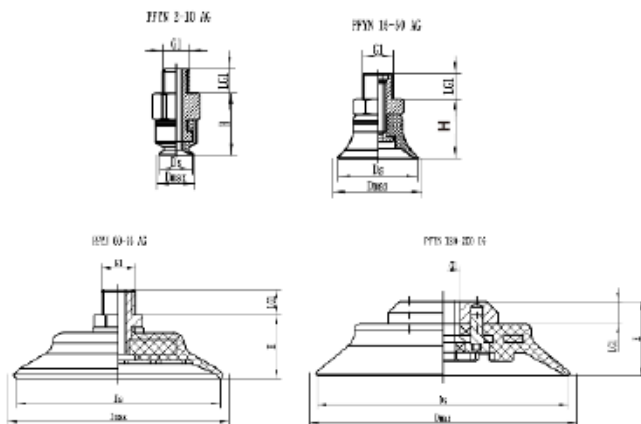

型号 (Model)	吸力 (N) <sup>1)</sup>	推荐真空管 内径(mm)	G1 (mm)	Ds (mm)	Dmax (mm)	H (mm)	LG1 (mm)	NBR-55 (黑色)	SI-55 (透明)	HT1-60 (蓝色)	重量 (Weight)
PFYN-2-...	0.12	2	M5-M	2.0	2.5	6.0	3.0	7.Y02131	7.Y02147	7.Y02163	1g
PFYN-3.5-...	0.42	2	M5-M	3.5	4.0	6.0	3.0	7.Y02132	7.Y02148	7.Y02164	1g
PFYN-5-...	0.75	2	M5-M	5.0	5.5	11.5	4.5	7.Y02133	7.Y02149	7.Y02165	1g
PFYN-6-...	1.2	2	M5-M	6.0	6.5	11.5	4.5	7.Y02134	7.Y02150	7.Y02166	1g
PFYN-8-...	2.3	2	M5-M	8.0	9.0	12.0	4.5	7.Y02135	7.Y02151	7.Y02167	1g
PFYN-10-...	4.0	2	M5-M	10.0	11.5	12.5	4.5	7.Y02136	7.Y02152	7.Y02168	4g
PFYN-15-...	9.0	4	G1/8-M	15.0	17.5	13.0	8.0	7.Y02137	7.Y02153	7.Y02169	5g
PFYN-20-...	15.5	4	G1/8-M	20.0	23.0	15.0	8.0	7.Y02138	7.Y02154	7.Y02170	6g
PFYN-25-...	26.5	4	G1/8-M	25.0	27.5	19.0	8.0	7.Y02139	7.Y02155	7.Y02171	7g
PFYN-30-...	34.0	4	G1/8-M	28.8	31.5	17.0	8.0	7.Y02140	7.Y02156	7.Y02172	8g
PFYN-35-...	44.0	4	G1/8-M	35.0	38.0	19.0	8.0	7.Y02141	7.Y02157	7.Y02173	11g
PFYN-40-...	57.7	4	G1/8-M	40.0	43.0	19.0	8.0	7.Y02142	7.Y02158	7.Y02174	12g
PFYN-50-...	91.0	4	G1/8-M	50.0	53.5	20.0	8.0	7.Y02143	7.Y02159	7.Y02175	15g
PFYN-60-...	125	6	G1/4-M	60.0	64.0	23.0	10.0	7.Y02144	7.Y02160	7.Y02176	34g
PFYN-80-...	260	6	G1/4-M	80.0	86.0	25.0	10.0	7.Y02145	7.Y02161	7.Y02177	63g
PFYN-95-...	350	6	G1/4-M	95.0	102.0	25.5	10.0	7.Y02146	7.Y02162	7.Y02178	102g
PFYN-120-...	540	9	G1/2-F	120.0	124	36.5	13.0	1.Y12969	1.Y12988	-	353g
PFYN-150-...	842	9	G1/2-F	147.5	158	45.5	13.0	1.Y12970	1.Y12989	1.Y13008	521g
PFYN-200-...	1498	9	G1/2-F	193.0	222	50.5	13.0	1.Y12971	1.Y12990	-	785g

(1) 上述规定吸力为在真空度为-0.6bar时的理论值, 对于表面光滑、干燥的工件而言, 未包括安全系数。

(1) The suction specified above is the theoretical value when the vacuum degree is -0.6bar. For smooth and dry workpieces, the safety factor is not included.

Materials 材质	Shore Hardness 硬度	A Flexibility 柔韧性	Abrasion resistance 耐磨性	UV & weather resistance 抗紫外线	Oil resistance 抗油污性	Heat resistance (in °C) 耐高温	
SI-55: Translucent Silicone 半透明硅胶	50	+++	-	-	-	-40 to 220	Translucent 半透明
HT1-60: Siton 特制复合材料(无痕)	60	+	++	-	++	-25 to 170	Blue 蓝色
NBR-55: Nitrile 丁腈橡胶	60	+	+	-	++	-30 to 120	Black 黑色

# 吸盘FSGA系列 (波纹管式/2层)

## Vacuum Cups FSGA Series

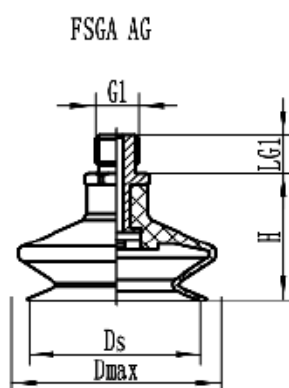

型号 (Model)	吸力 (N) <sup>(1)</sup>	拉脱力 (N) <sup>(1)(2)</sup>	推荐真空管 内径(mm)	G1 (mm)	Ds (mm)	Dmax(S) (mm)	H (mm)	LG1 (mm)	NBR-55 (黑色)	SI-55 (透明)	HT1-60 (蓝色)	重量 (Weight)
FSGA-6-...	0.4	1.4	4	M5-M	5.7	8.0	14.0	4.5	7.Y02179	7.Y02191	7.Y02203	2g
FSGA-11-...	0.95	3.8	4	M5-M	10.1	13.0	21.0	5.0	7.Y02180	7.Y02192	7.Y02204	2g
FSGA-14-...	1.2	5.0	4	M5-M	12.5	14.5	20.5	5.0	7.Y02181	7.Y02193	7.Y02205	2g
FSGA-16-...	2.3	6.7	4	G1/8-M	15.6	18.5	25.2	7.5	7.Y02182	7.Y02194	7.Y02206	5g
FSGA-20-...	4.7	10.7	4	G1/8-M	18.1	21.0	21.2	7.5	7.Y02183	7.Y02195	7.Y02207	5g
FSGA-22-...	5.7	15.2	4	G1/8-M	21.5	25.0	25.0	7.5	7.Y02184	7.Y02196	7.Y02208	6g
FSGA-25-...	5.3	17.3	4	G1/8-M	22.5	26.5	29.0	7.5	7.Y02185	7.Y02197	7.Y02209	6g
FSGA-33-...	13.6	39.6	6	G1/8-M	30.0	38.0	31.0	11.0	7.Y02186	7.Y02198	7.Y02210	16g
FSGA-43-...	22.8	64.5	6	G1/4-M	38.0	47.5	31.6	11.0	7.Y02187	7.Y02199	7.Y02211	19g
FSGA-53-...	51.3	95	6	G1/4-M	50.0	60.0	38.0	11.0	7.Y02188	7.Y02200	7.Y02212	27g
FSGA-63-...	85.0	135	6	G1/4-M	60.0	68.0	38.0	11.0	7.Y02189	7.Y02201	7.Y02213	34g
FSGA-78-...	137.4	218	6	G1/4-M	74.0	84.5	53.0	11.0	7.Y02190	7.Y02202	7.Y02214	71g

(1)上述规定吸力为在真空度为-0.6bar时的理论值,对于表面光滑、干燥的工件而言,未包括安全系数

(1) The suction specified above is the theoretical value when the vacuum degree is -0.6bar. For smooth and dry workpieces, the safety factor is not included.

(2)天然橡胶材质的吸盘,其拉脱力约降低40%。

(2) The pull-off force of the vacuum cup made of natural rubber is reduced by about 40%.

Materials 材质	Shore Hardness 硬度	A Flexibility 柔韧性	Abrasion resistance 耐磨性	UV & weather resistance 抗紫外线	Oil resistance 抗油污性	Heat resistance (in °C) 耐高温	
SI-55: Translucent Silicone 半透明硅胶	50	+++	-	-	-	-40 to 220	Translucent 半透明
HT1-60: Siton 特制复合材料(无痕)	60	+	++	-	++	-25 to 170	Blue 蓝色
NBR-55: Nitrile 丁腈橡胶	60	+	+	-	++	-30 to 120	Black 黑色

Profile- SUS Tube  
型材、钢管

Stents Module  
支架模组

Quick Changer  
快换

Grip Module  
夹具模组

Air Nipper  
气动剪刀

Vacuum Module  
真空组件

Accessory Components  
附件

# 吸盘FSG系列(波纹管式/3层)

## Vacuum Cups FSG Series

Profile, SUS Tube  
型材、钢管

Stents Module  
支架模组

Quick Changer  
快换

Grip Module  
夹具组件

Air Nipper  
气动夹刀

Vacuum Module  
真空组件

Accessory Components  
附件

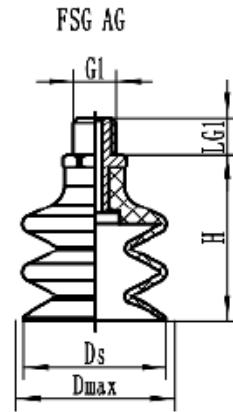
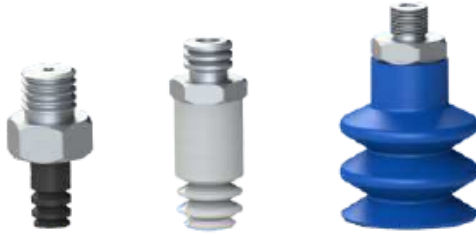

型号 (Model)	吸力 (N) <sup>(1)</sup>	拉脱力 (N) <sup>(1)(2)</sup>	推荐真空管 内径(mm)	G1 (mm)	Dmax(S) (mm)	Ds (mm)	H (mm)	LG1 (mm)	NBR-55 (黑色)	SI-55 (透明)	HT1-60 (蓝色)	重量 (Weight)
FSG-3-...	0.2	0.4	2	M5-M	4.0	3.0	8.7	3.0	7.Y02215	7.Y02230	7.Y02245	1g
FSG-4-...	0.3	0.6	2	M5-M	7.0	3.8	19.0	5.0	7.Y02216	7.Y02231	7.Y02246	2g
FSG-5-...	0.2	0.8	2	M5-M	7.0	5.0	19.0	5.0	7.Y02217	7.Y02232	7.Y02247	2g
FSG-7-...	0.1	0.9	4	M5-M	9.0	5.9	19.0	5.0	7.Y02218	7.Y02233	7.Y02248	2g
FSG-9-...	0.7	2.3	4	M5-M	9.5	9.0	20.0	5.0	7.Y02219	7.Y02234	7.Y02249	2g
FSG-12-...	0.9	3.5	4	M5-M	13.0	12.0	26.0	5.0	7.Y02220	7.Y02235	7.Y02250	2g
FSG-14-...	1.2	5.7	4	M5-M	15.5	14.5	27.8	5.0	7.Y02221	7.Y02236	7.Y02251	3g
FSG-18-...	2.3	8.5	4	G1/8-M	19.0	17.2	28.6	7.5	7.Y02222	7.Y02237	7.Y02252	6g
FSG-20-...	3.8	12.1	4	G1/8-M	21.0	20.0	28.1	7.5	7.Y02223	7.Y02238	7.Y02253	6g
FSG-25-...	4.5	19.0	4	G1/8-M	26.0	23.0	40.0	7.5	7.Y02224	7.Y02239	7.Y02254	8g
FSG-32-...	12.0	36.9	6	G1/8-M	33.5	32.0	41.5	11.0	7.Y02225	7.Y02240	7.Y02255	17g
FSG-42-...	13.6	44	6	G1/8-M	45.0	42.6	50.0	11.0	7.Y02226	7.Y02241	7.Y02256	27g
FSG-52-...	27.0	96	6	G1/8-M	55.0	52.5	52.7	11.0	7.Y02227	7.Y02242	7.Y02257	32g
FSG-62-...	39.6	137	6	G1/8-M	65.0	62.2	58.0	11.0	7.Y02228	7.Y02243	7.Y02258	60g
FSG-88-...	45.2	286	9	G1/4-M	95.5	89.0	92.5	11.0	7.Y02229	7.Y02244	-	173g

(1)上述规定吸力为在真空度为-0.6bar时的理论值,对于表面光滑、干燥的工件而言,未包括安全系数

(1) The suction specified above is the theoretical value when the vacuum degree is -0.6bar. For smooth and dry workpieces, the safety factor is not included.

(2)天然橡胶材质的吸盘,其拉脱力约降低40%。

(2) The pull-off force of the vacuum cup made of natural rubber is reduced by about 40%.

Materials 材质	Shore Hardness 硬度	A Flexibility 柔韧性	Abrasion resistance 耐磨性	UV & weather resistance 抗紫外线	Oil resistance 抗油污性	Heat resistance (in °C) 耐高温	
SI-55: Translucent Silicone 半透明硅胶	50	+++	-	-	-	-40 to 220	Translucent 半透明
HT1-60: Siton 特制复合材料(无痕)	60	+	++	-	++	-25 to 170	Blue 蓝色
NBR-55: Nitrile 丁腈橡胶	60	+	+	-	++	-30 to 120	Black 黑色

# 吸盘SGON系列(扁平长方型)

## Vacuum Cups SGON Series

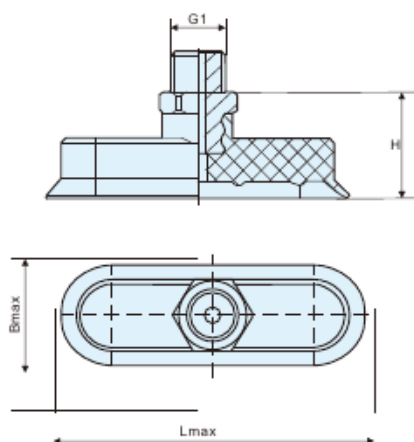

型号 (Model)	吸力 (N) <sup>(1)</sup>	推荐真空管内径 (mm)	G1 (mm)	Bmax (mm)	Lmax (mm)	H (mm)	NBR-60 (黑色)	SI-60 (透明)	HT1-60 (蓝色)	重量 (Weight)
SGON-4x2-...	0.42	2	M3-M	2.5	4.5	8	1.Y13068	1.Y13079	1.Y13090	2g
SGON-7x3.5-...	1.0	2	M3-M	4.5	7.5	8	1.Y13069	1.Y13080	1.Y13091	2g
SGON-12x4-...	1.8	2	M5-M	5.0	13.0	18	1.Y13070	1.Y13081	1.Y13092	3g
SGON-15x5-...	3.1	2	M5-M	5.5	15.5	17	1.Y13071	1.Y13082	1.Y13093	3g
SGON-18x6-...	4.5	2	M5-M	7.0	18.5	17	1.Y13072	1.Y13083	1.Y13094	3g
SGON-24x8-...	8.0	4	G1/8-M	9.0	24.5	17	1.Y13073	1.Y13084	1.Y13095	7g
SGON-30x10-...	12.2	4	G1/8-M	11.5	30.5	17	1.Y13074	1.Y13085	1.Y13096	7g
SGON-45x15-...	28.2	6	G1/4-M	16.5	46.0	26	1.Y13075	1.Y13086	1.Y13097	15g
SGON-60x20-...	50.1	6	G1/4-M	22.0	61.0	26	1.Y13076	1.Y13087	1.Y13098	19g
SGON-75x25-...	78.3	6	G1/4-M	27.5	77.0	26	1.Y13077	1.Y13088	1.Y13099	27g
SGON-90x30-...	112.6	6	G1/4-M	33.0	92.5	26	1.Y13078	1.Y13089	1.Y13100	35g

(1)上述规定吸力为在真空度为-0.6bar时的理论值,对于表面光滑、干燥的工件而言,未包括安全系数

(1) The suction specified above is the theoretical value when the vacuum degree is -0.6bar. For smooth and dry workpieces, the safety factor is not included.

\* SGON-24x8 及更大的替换吸盘垫配有专用固定夹。

\* SGON-24x8 and larger replacement vacuum cup pads are equipped with special fixing clips.

Materials 材质	Shore Hardness 硬度	A Flexibility 柔性	Abrasion resistance 耐磨性	UV & weather resistance 抗紫外线	Oil resistance 抗油污性	Heat resistance (in °C) 耐高温	
SI-55: Translucent Silicone 半透明硅胶	50	+++	-	-	-	-40 to 220	Translucent 半透明
HT1-60: Siton 特制复合材料(无痕)	60	+	++	-	++	-25 to 170	Blue 蓝色
NBR-55: Nitrile 丁腈橡胶	60	+	+	-	++	-30 to 120	Black 黑色

Profile-  
SUSTube  
型材、钢管

Stents Module  
支架模组

Quick  
Changer  
快换

Grip Module  
夹具组件

Air  
Nipper  
气动剪刀

Vacuum Module  
真空组件

Accessory Components  
附件

# 吸盘VSH系列(扁平式)

## Vacuum Cups VSH Series

VSH-S2...VSH-S10

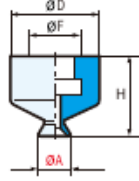

VSH-S12...VSH-S30



VSH-M4...VSH-M10

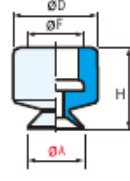

VSH-M12...VSH-M50



		$\uparrow$ (N) <sup>(1)</sup>	$\uparrow$ (N) <sup>(1)</sup>	ØA(mm)	H(mm)	ØD(mm)	ØF(mm)	SI(半透明)	SP(海绵)
VSH-S2		0.5	0.1	2	13	11	7	1.Y07282	-
VSH-S4		0.7	0.2	4	10	10	7	1.Y07283	-
VSH-S6		0.9	0.3	6	10	10	7	1.Y07284	-
VSH-S8		1.1	0.5	8	10	10	7	1.Y07285	-
VSH-S10		1.6	0.8	10	10	10	7	1.Y07286	-
VSH-S12		2.0	1.5	12	12	10	7	1.Y07287	-
VSH-S15		3.7	1.8	15	12.5	11	7	1.Y07288	-
VSH-S20		6.1	3.0	20	13	12	7	1.Y07289	-
VSH-S25		9.4	4.7	25	13	13	7	1.Y07290	-
VSH-S30		15.9	7.9	30	13	13	7	1.Y07291	-
VSH-M4		0.7	0.2	4	15	15	11	1.Y07292	-
VSH-M6		0.9	0.3	6	15	15	11	1.Y07293	-
VSH-M8		1.1	0.5	8	15	15	11	1.Y07294	-
VSH-M10		1.6	0.8	10	15	15	11	1.Y07295	1.Y12885
VSH-M12		2.0	1.5	12	15	15	11	1.Y07296	1.Y12886
VSH-M15		3.7	1.8	15	15	15	11	1.Y07297	1.Y12887
VSH-M20		6.1	3.0	20	15	15	11	1.Y07298	1.Y07530
VSH-M25		9.4	4.7	25	15	15	11	1.Y07299	1.Y12888
VSH-M30		15.9	7.9	30	15	16	11	1.Y07300	1.Y07758
VSH-M40		26.7	13.4	40	15	17	11	1.Y07301	1.Y07894
VSH-M50		38.3	19.1	50	15	20	11	1.Y07302	1.Y07895

(1)真空度为65%时吸盘的实际吸附力,建议水平工作时安全系数为2,垂直工作时安全系数为4。

(1) Actual force of the suction cup in use with 65% vacuum and including a safety factor of 2 for horizontal handling and a factor of 4 for vertical handling.



	吸盘座 Vacuum Cup Fitting		吸盘 Vacuum Cups
	VM11-M5, VM11-G18		VSH-S2~VSH-S30
	VFS 系列金具 (VFS Series Stem)		
	VFST 系列金具 (VFST Series Stem)		
	VM10-G 1/8, VM27-M5		VSH-M4~VSH-M50
	VFM 系列金具 (VFM Series Stem)		
	VFMT 系列金具 (VFMT Series Stem)		

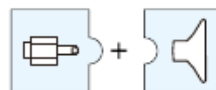

直插式  
Factory-crimped fitting

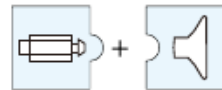

直插式  
Hollow shaft fitting

Materials 材质	Shore Hardness 硬度	A Flexibility 柔韧性	Abrasion resistance 耐磨性	UV & weather resistance 抗紫外线	Oil resistance 抗油污性	Heat resistance (in °C) 耐高温	Translucent 半透明
SI: Translucent Silicone 半透明硅胶	50	+++	-	-	-	-40 to 220	Translucent 半透明

# 吸盘VSH2系列(波纹管式/2层)

## Vacuum Cups VSH2 Series

VSH2-S4...VSH2-S20

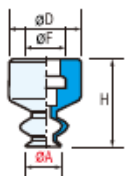

VSH2-S25...VSH2-S30

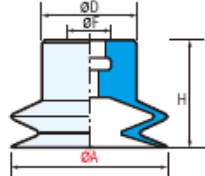

VSH2-M6...VSH2-M25

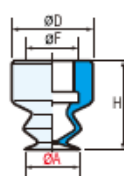

VSH2-M30...VSH2-M50

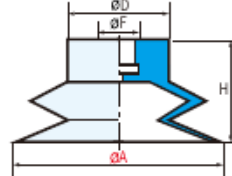

		$\Delta$ (N) <sup>(1)</sup>	$\Delta$ (N) <sup>(1)</sup>	ØA(mm)	H(mm)	ØD(mm)	ØF(mm)	SI(半透明)	SP(海绵)
VSH2-S4		0.3	0.1	4	15	12	7	1.Y07303	-
VSH2-S6		0.5	0.2	6	15	12	7	1.Y07304	-
VSH2-S8		1.2	0.7	8	15	12	7	1.Y07305	-
VSH2-S10		1.7	0.9	10	15	12	7	1.Y07306	-
VSH2-S12		2.5	1.3	12	15	12	7	1.Y07307	-
VSH2-S15		2.7	1.3	15	17	15	7	1.Y07308	-
VSH2-S20		5.6	2.8	20	16.5	15	7	1.Y07309	-
VSH2-S25		7.9	4.0	25	18	15	7	1.Y07310	-
VSH2-S30		12	6	30	20	15	7	1.Y07311	-
VSH2-M6		0.5	0.2	6	18	15	11	1.Y07312	-
VSH2-M8		1.2	0.7	8	17	15	11	1.Y07313	-
VSH2-M10		1.7	0.9	10	17	15	11	1.Y07314	1.Y08294
VSH2-M12		2.5	1.3	12	17	15	11	1.Y07315	1.Y08295
VSH2-M15		2.7	1.3	15	18	15	11	1.Y07316	1.Y08296
VSH2-M20		5.6	2.8	20	18	15	11	1.Y07317	1.Y07929
VSH2-M25		7.9	4.0	25	18	15	11	1.Y07318	1.Y08349
VSH2-M30		12	6	30	19	18	11	1.Y07319	1.Y08056
VSH2-M35		13.9	6.9	35	24	18	11	1.Y07320	-
VSH2-M40		20.2	10.1	40	22	23	11	1.Y07321	1.Y08104
VSH2-M50		40	20	50	25	22	11	1.Y07322	1.Y08105

(1)真空度为65%时吸盘的实际吸附力, 建议水平工作时安全系数为2, 垂直工作时安全系数为4。

(1) Actual force of the suction cup in use with 65% vacuum and including a safety factor of 2 for horizontal handling and a factor of 4 for vertical handling.



	吸盘座 Vacuum Cup Fitting		吸盘 Vacuum Cups
	VM11-M5, VM11-G18 VFS 系列金具 (VFS Series Stem) VFST 系列金具 (VFST Series Stem)		VSH2-S4-VSH2-S30
	VM10-G 1/8, VM27-M5 VFM 系列金具 (VFM Series Stem) VFMT 系列金具 (VFMT Series Stem)		VSH2-M6-VSH2-M50

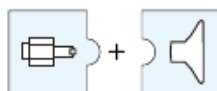

直插式  
Factory-crimped fitting

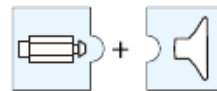

直插式  
Hollow shaft fitting

Materials 材质	Shore Hardness 硬度	A Flexibility 柔韧性	Abrasion resistance 耐磨性	UV & weather resistance 抗紫外线	Oil resistance 抗油污性	Heat resistance (in °C) 耐高温	Translucent 半透明
SI: Translucent Silicone 半透明硅胶	50	+++	-	-	-	-40 to 220	Translucent 半透明

Profile- SUS Tube  
型材、钢管

Stents Module  
支架模组

Quick Changer  
快换

Grip Module  
夹具模组

Air Nipper  
气动剪刀

Vacuum Module  
真空组件

Accessory Components  
附件

# 吸盘VSH3系列(波纹管式/3层)

## Vacuum Cups VSH3 Series

Profile, SUS Tube  
型材、钢管

Stents Module  
支架模组

Quick Changer  
快换

Grip Module  
夹具组件

Air Gripper  
气动夹刀

Vacuum Module  
真空组件

Accessory Components  
附件

VSH3-S6...VSH3-S8

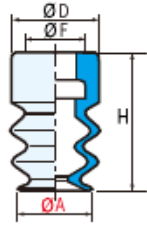

VSH3-S10...VSH3-S15

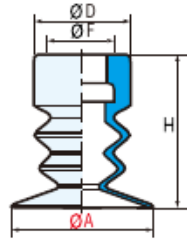

VSH3-M8...VSH3-M30

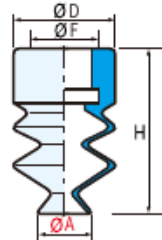

VSH3-M40...VSH3-M50

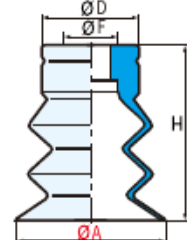

		$\Delta$ (N) <sup>(1)</sup>	ØA(mm)	H(mm)	ØD(mm)	ØF(mm)	SI(半透明)	SP(海绵)
VSH3-S6		0.5	6	15	10	7	1.Y07323	-
VSH3-S8		1.0	8	15	12	7	1.Y07324	-
VSH3-S10		1.5	10	15	10	7	1.Y07325	-
VSH3-S12		2.8	12	15	10	7	1.Y07326	-
VSH3-S15		3.0	15	15	12	7	1.Y07327	-
VSH3-M8		1.0	8	20	15	11	1.Y07328	-
VSH3-M10		1.5	10	18	15	11	1.Y07329	1.Y09163
VSH3-M12		2.8	12	21	15	11	1.Y07330	1.Y09162
VSH3-M15		3.0	15	21	15	11	1.Y07331	1.Y09161
VSH3-M20		4.6	20	24	15	11	1.Y07332	1.Y08134
VSH3-M25		6.5	25	24	15	11	1.Y07333	1.Y09065
VSH3-M30		12.1	30	35	15	11	1.Y07334	1.Y08167
VSH3-M40		20.5	40	43	20	11	1.Y07335	1.Y08168
VSH3-M50		25	50	42	20	11	1.Y07336	1.Y08234

(1)真空度为65%时吸盘的实际吸附力,建议水平工作时安全系数为2,垂直工作时安全系数为4。

(1) Actual force of the suction cup in use with 65% vacuum and including a safety factor of 2 for horizontal handling and a factor of 4 for vertical handling.



	吸盘座 Vacuum Cup Fitting		吸盘 Vacuum Cups
	VM11-M5, VM11-G18		VSH3-S6-VSH3-S15
	VFS 系列金具 (VFS Series Stem)		
	VFST 系列金具 (VFST Series Stem)		
	VM10-G 1/8, VM27-M5		VSH3-M8-VSH3-M50
	VFM 系列金具 (VFM Series Stem)		
	VFMT 系列金具 (VFMT Series Stem)		

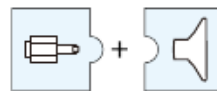

直插式  
Factory-crimped fitting

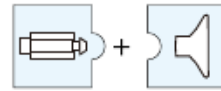

直插式  
Hollow shaft fitting

Materials 材质	Shore Hardness 硬度	A Flexibility 柔韧性	Abrasion resistance 耐磨性	UV & weather resistance 抗紫外线	Oil resistance 抗油污性	Heat resistance (in °C) 耐高温	Translucent 半透明
SI: Translucent Silicone 半透明硅胶	50	+++	-	-	-	-40 to 220	Translucent 半透明

## 吸盘SAF系列(扁平式)

### Vacuum Cups SAF Series

功能: 防滑、防油、防水(多用于汽车钣金, 玻璃等吸附)

Functions: anti-skid, oil-proof and water-proof (mostly used for adsorption of automobile sheet metal, glass, etc.)

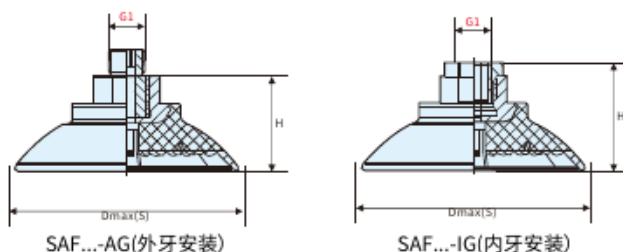

货号 (PN)	型号 (Model)	吸力 (N) <sup>(1)</sup>	侧向力 (N) <sup>(2)</sup>	推荐真空管内径(mm)	Dmax(S) (mm)	G1 (mm)	H (mm)	LG1 (mm)	重量 (Weight)
1.Y13010	SAF-30-G3/8AG	38	30	4	34	G3/8-M	20	10	17g
1.Y13011	SAF-30-G3/8IG	38	30	4	34	G3/8-F	36	9	43g
1.Y13012	SAF-40-G3/8AG	69	52	4	46	G3/8-M	22	10	19g
1.Y13013	SAF-40-G3/8IG	69	52	4	46	G3/8-F	38	9	45g
1.Y13014	SAF-50-G3/8AG	100	80	4	56	G3/8-M	28	10	40g
1.Y13015	SAF-50-G3/8IG	100	80	4	56	G3/8-F	28	15	31g
1.Y13016	SAF-60-G3/8AG	150	105	6	67	G3/8-M	31	10	46g
1.Y13017	SAF-60-G3/8IG	150	105	6	67	G3/8-F	31	15	37g
1.Y13018	SAF-80-G3/8AG	272	205	6	89	G3/8-M	35	10	65g
1.Y13019	SAF-80-G3/8IG	272	205	6	89	G3/8-F	35	15	56g
1.Y13020	SAF-100-G3/8AG	430	310	6	110	G3/8-M	36	10	76g
1.Y13021	SAF-100-G3/8IG	430	310	6	110	G3/8-F	36	15	67g
1.Y13023	SAF-125-G3/8IG	660	475	9	135	G3/8-F	43	15	146g

## 吸盘SAOF系列(扁平式)

### Vacuum Cups SAOF Series

功能: 防滑、防油、防水(多用于汽车钣金, 玻璃等吸附)

Functions: anti-skid, oil-proof and water-proof (mostly used for adsorption of automobile sheet metal, glass, etc.)

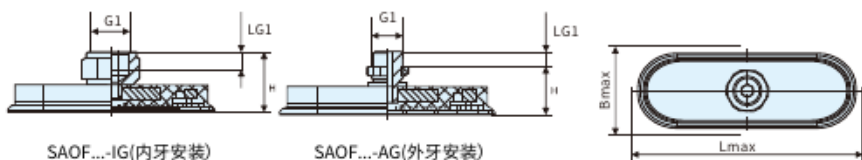

货号 (PN)	型号 (Model)	吸力 (N) <sup>(1)</sup>	侧向力 (N) <sup>(2)</sup>	推荐真空管内径(mm)	Dmax(S) (mm)	G1 (mm)	H (mm)	LG1 (mm)	Lmax(S) (mm)	重量 (Weight)
1.Y13024	SAOF-50x16-G3/8AG	31	24	4	18	G3/8-M	26	8	52	24g
1.Y13025	SAOF-50x16-G3/8IG	31	24	4	18	G3/8-F	34	9	52	45g
1.Y13026	SAOF-60x23-G3/8AG	57	37	4	25	G3/8-M	18	8	64	21g
1.Y13027	SAOF-60x23-G3/8IG	57	37	4	25	G3/8-F	26	9	64	42g
1.Y13028	SAOF-90x30-G3/8AG	122	96	4	34	G3/8-M	19	8	94	39g
1.Y13029	SAOF-90x30-G3/8IG	122	96	4	34	G3/8-F	27	9	94	60g
1.Y13030	SAOF-80x40-G3/8AG	140	110	4	43	G3/8-M	20	8	85	34g
1.Y13031	SAOF-80x40-G3/8IG	140	110	4	43	G3/8-F	28	9	85	55g
1.Y13032	SAOF-100x50-G3/8AG	217	181	6	54	G3/8-M	22	8	106	63g
1.Y13033	SAOF-100x50-G3/8IG	217	181	6	54	G3/8-F	31	9	106	85g
1.Y13034	SAOF-120x60-G3/8AG	312	254	6	65	G3/8-M	24	8	128	77g
1.Y13035	SAOF-120x60-G3/8IG	312	254	6	65	G3/8-F	33	9	128	99g
1.Y13037	SAOF-140x70-G3/8IG	425	344	6	76	G3/8-F	34	9	149	107g

Profile- SUS Tube  
型材、钢管

Stents Module  
支架模组

Quick Changer  
快换

Grip Module  
夹具组件

Air Nipper  
气动剪刀

Vacuum Module  
真空组件

Accessory Components  
附件

## 吸盘SAB系列(波纹管式/2层)

### Vacuum Cups SAB Series

功能: 防滑、防油、防水(多用于汽车钣金, 玻璃等吸附)

Functions: anti-skid, oil-proof and water-proof (mostly used for adsorption of automobile sheet metal, glass, etc.)

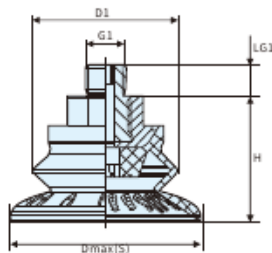

SAB...-AG(外牙安装)

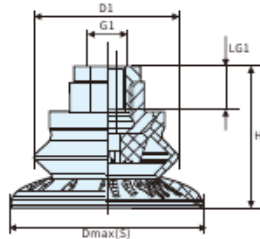

SAB...-IG(内牙安装)

货号 (PN)	型号 (Model)	吸力 (N) <sup>(1)</sup>	拉脱力 (N) <sup>(1)</sup>	侧向力 (N) <sup>(1)</sup>	推荐真空管内径(mm)	Dmax(S) (mm)	G1 (mm)	D1 (mm)	H (mm)	LG1 (mm)	重量 (Weight)
1.Y13038	SAB-22-G3/8AG	16	24	18	4	24	G3/8-M	22	25	10	15g
1.Y13039	SAB-22-G3/8IG	16	24	18	4	24	G3/8-F	22	41	9.5	41g
1.Y13040	SAB-30-G3/8AG	22	33	30	4	34	G3/8-M	32	28	10	19g
1.Y13041	SAB-30-G3/8IG	22	33	30	4	34	G3/8-F	32	44	9.5	45g
1.Y13042	SAB-40-G3/8AG	38	59	36	4	45	G3/8-M	32	28.8	10	20g
1.Y13043	SAB-40-G3/8IG	38	59	36	4	45	G3/8-F	32	44.8	9.5	45g
1.Y13044	SAB-50-G3/8AG	53	87	55	4	56	G3/8-M	40	36.9	10	41g
1.Y13045	SAB-50-G3/8IG	53	87	55	4	56	G3/8-F	40	36.9	15	32g
1.Y13046	SAB-60-G3/8AG	82	130	82	6	67	G3/8-M	48	41.3	10	49g
1.Y13047	SAB-60-G3/8IG	82	130	82	6	67	G3/8-F	48	41.3	15	40g
1.Y13048	SAB-80-G3/8AG	135	221	145	6	89	G3/8-M	64	49.9	10	72g
1.Y13049	SAB-80-G3/8IG	135	221	145	6	89	G3/8-F	64	49.9	15	63g
1.Y13050	SAB-100-G3/8AG	190	357	220	6	110	G3/8-M	77	56.6	10	97g
1.Y13051	SAB-100-G3/8IG	190	357	220	6	110	G3/8-F	77	56.6	15	88g
1.Y13052	SAB-125-G3/8AG	250	558	352	9	135	G3/8-M	94	67.8	10	179g
1.Y13053	SAB-125-G3/8IG	250	558	352	9	135	G3/8-F	94	67.8	15	170g

## 吸盘SAOB系列(波纹管式/2层)

### Vacuum Cups SAOB Series

功能: 防滑、防油、防水(多用于汽车钣金, 玻璃等吸附)

Functions: anti-skid, oil-proof and water-proof (mostly used for adsorption of automobile sheet metal, glass, etc.)

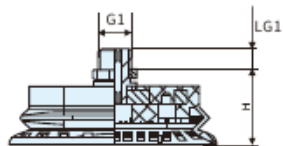

SAOB...-AG(外牙安装)

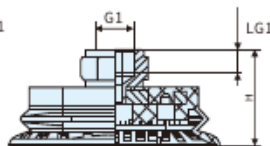

SAOB...-IG(内牙安装)

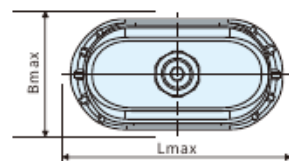

货号 (PN)	型号 (Model)	吸力 (N) <sup>(1)</sup>	拉脱力 (N) <sup>(1)</sup>	侧向力 (N) <sup>(1)</sup>	推荐真空管内径(mm)	Bmax(S) (mm)	Lmax(S) (mm)	G1 (mm)	H (mm)	LG1 (mm)	重量 (Weight)
1.Y13054	SAOB-60x30-G3/8AG	38	70	73	4	33	63	G3/8-M	27.0	8	49g
1.Y13055	SAOB-60x30-G3/8IG	38	70	73	4	33	63	G3/8-F	35.0	9	70g
1.Y13056	SAOB-80x40-G3/8AG	65	132	153	6	43	83	G3/8-M	29.7	8	67g
1.Y13057	SAOB-80x40-G3/8IG	65	132	153	6	43	83	G3/8-F	37.7	9	88g
1.Y13058	SAOB-110x55-G3/8AG	110	234	299	6	59	114	G3/8-M	35.5	8	87g
1.Y13059	SAOB-110x55-G3/8IG	110	234	299	6	59	114	G3/8-F	43.5	9	109g
1.Y13061	SAOB-140x70-G3/8IG	165	355	473	6	75	146	G3/8-F	47.5	9	142g

# 吸盘座

## Vacuum Cups Fitting

### 型号表示方法

#### Model representation methods

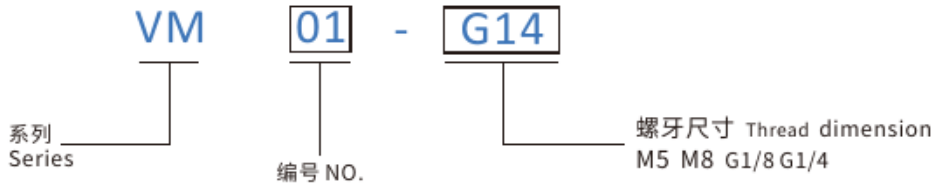

吸盘座 Vacuum Cup Fitting			
尺寸 Dimension			
货号(PN)	7.Y00703	7.Y00709	7.Y00768
型号(Model)	VM02-G18	VM04-G14	VM06-G14
重量(Weight)	3.5g	7.0g	9.7g

吸盘座 Vacuum Cup Fitting			
尺寸 Dimension			
货号(PN)	7.Y00767	1.Y05275	1.Y05274
型号(Model)	VM07-G18	VM08-M8	VM09-M5
重量(Weight)	3.3g	8.3g	1.4g



# 吸盘座

## Vacuum Cups Fitting

### 型号表示方法

#### Model representation methods

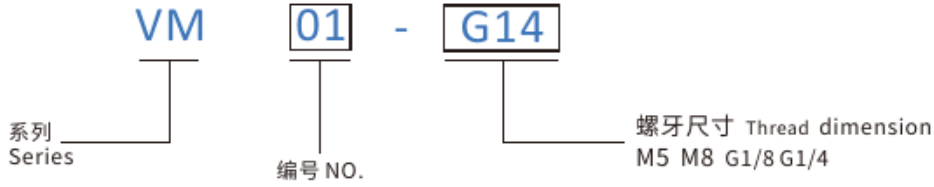

吸盘座 Vacuum Cup Fitting			
尺寸 Dimension			
货号(PN)	7.Y00759	7.Y00758	7.Y00757
型号(Model)	VM15-G18	VM16-G18	VM17-G18
重量(Weight)	17.8g	3.8g	2.9g

吸盘座 Vacuum Cup Fitting			
尺寸 Dimension			
货号(PN)	1.Y05314	4.Y00058	1.Y01986
型号(Model)	VM18-M5	VM20-G14	VM21-M5
重量(Weight)	4.6g	9.5g	1.8g

# 吸盘座

## Vacuum Cups Fitting

### 型号表示方法

#### Model representation methods

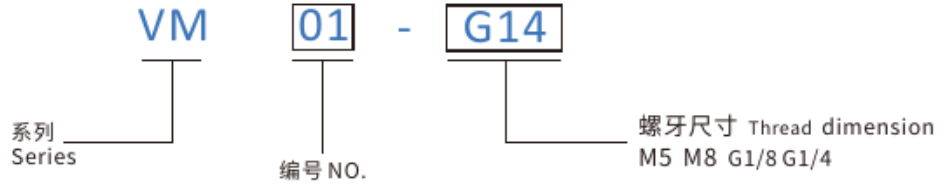

吸盘座 Vacuum Cup Fitting			
尺寸 Dimension			
货号(PN)	1.Y05790	7.Y00900	7.Y00898
型号(Model)	VM22-M5	VM23-G18	VM24-G18
重量(Weight)	2.9g	8.9g	5.5g

吸盘座 Vacuum Cup Fitting			
尺寸 Dimension			
货号(PN)	7.Y00928	1.Y01097	7.Y00475
型号(Model)	VM25-M3	VM27-M5	VM28-M8
重量(Weight)	0.2g	6.2g	1.9g

Profile、SUS Tube  
型材、钢管

Stents Module  
支架模组

Quick Changer  
快换

Grip Module  
夹具组件

Air Nipper  
气动剪刀

Vacuum Module  
真空组件

Accessory Components  
附件

# 吸盘座

## Vacuum Cups Fitting

### 型号表示方法

#### Model representation methods

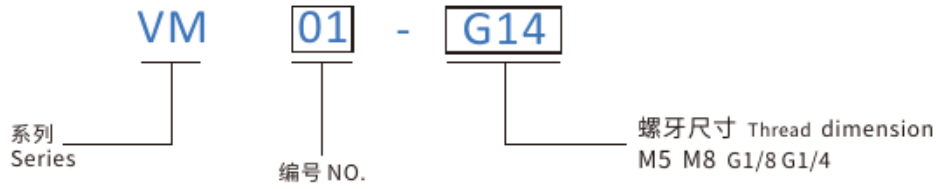

吸盘座 Vacuum Cup Fitting			
尺寸 Dimension			
货号(PN)	7.Y01036	7.Y01037	7.Y01038
型号(Model)	VM29-M5	VM30-G18	VM31-M5
重量(Weight)	1.1g	1.3g	3.8g

吸盘座 Vacuum Cup Fitting			
尺寸 Dimension			
货号(PN)	7.Y01039	7.Y01040	7.Y01041
型号(Model)	VM32-G18	VM33-M5	VM34-G18
重量(Weight)	4.1g	4.0g	4.3g

# 吸盘座

## Vacuum Cups Fitting

### 型号表示方法

#### Model representation methods

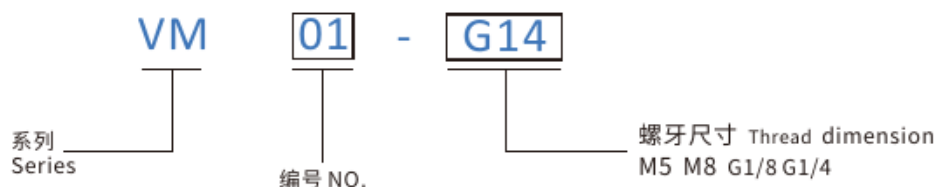

吸盘座 Vacuum Cup Fitting			
尺寸 Dimension			
货号(PN)	7.Y01042	7.Y01043	7.Y01044
型号(Model)	VM35-M5	VM36-G18	VM37-M5
重量(Weight)	3.4g	3.7g	4.3g

吸盘座 Vacuum Cup Fitting			
尺寸 Dimension			
货号(PN)	7.Y01045	7.Y01046	7.Y01047
型号(Model)	VM38-G18	VM39-M5	VM40-G18
重量(Weight)	4.7g	2.6g	4.0g

# 吸盘座

## Vacuum Cups Fitting

### 型号表示方法

#### Model representation methods

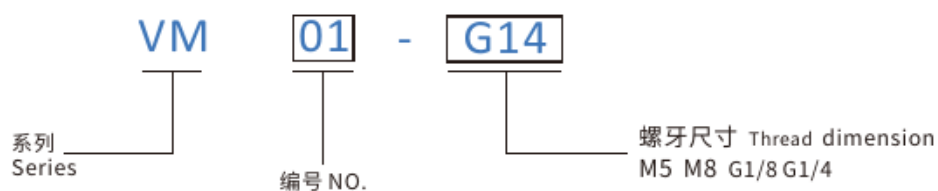

吸盘座 Vacuum Cup Fitting			
尺寸 Dimension			
货号(PN)	7.Y01048	7.Y02013	7.Y02059
型号(Model)	VM41-G14	VM10-G18-F	VM42-G14
重量(Weight)	14g	5.7g	6.5g

# 吸盘金具转接头

## Vacuum Cup Connector

### 型号表示方法

#### Model representation methods

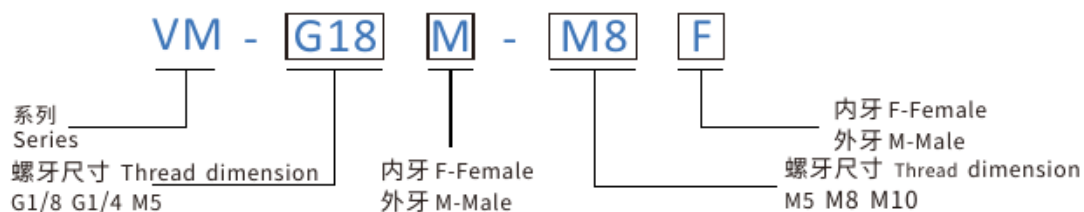

吸盘金具 转接头 Vacuum Cup Connector			
尺寸 Dimension			
货号(PN)	7.Y00808	7.Y00756	7.Y00755
型号(Model)	VM-G18M-M10M	VM-G14M-M10M	VM-G18M-M5F
重量(Weight)	4.5g	4.7g	2.9g

吸盘金具 转接头 Vacuum Cup Connector			
尺寸 Dimension			
货号(PN)	7.Y00754	7.Y00473	7.Y00474
型号(Model)	VM-G18M-M8F	VM-M5M-M8F	VM-M5M-G18F
重量(Weight)	6.2g	5.6g	4.9g



# 真空吸盘悬件

## Vacuum Cup Suspensions

当机械手移动时, 这些悬件可用来保持吸盘的位置。  
CRG 为塑料应用提供了广泛的独特设计。

它们一般通过固定支架安装在治具上。

The suspensions (or buffers, or level compensators) are used to keep the suction cups in position as the robot approaches.  
CRG offers a range specifically designed for Plastics applications.

They are typically mounted on EAOTs (End Of Arm Toolings) with Mounting brackets.

### 型号表示方法

#### Model representation methods

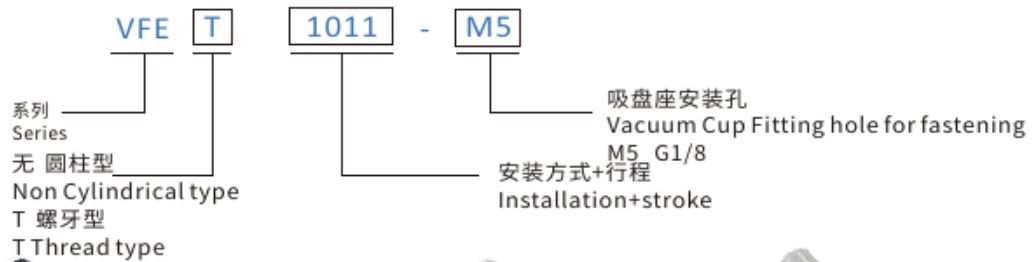

VFE



VFR



VFN



VFET



VFRT



VFNT

带平滑主体的悬件  
Suspensions with smooth body

- VFR
- VFN
- VFE



带螺纹主体的悬件  
Suspensions with threaded body

- VFRT
- VFNT
- VFET



非可旋转悬件  
Non-rotative suspensions

- VFN
- VFNT
- VFE
- VFET



可旋转悬件  
Rotative suspensions

- VFR
- VFRT



# 非可旋转悬件

## Non-rotative Suspensions

主体和杆由阳极铝制成。  
拥有高负载能力的非可旋转杆。  
压力范围: -1 ~ 8 bar。

Body and rod in anodized aluminum.  
Non-rotative rod with high load capability.  
Pressure range: -1 ~ 8 bar.

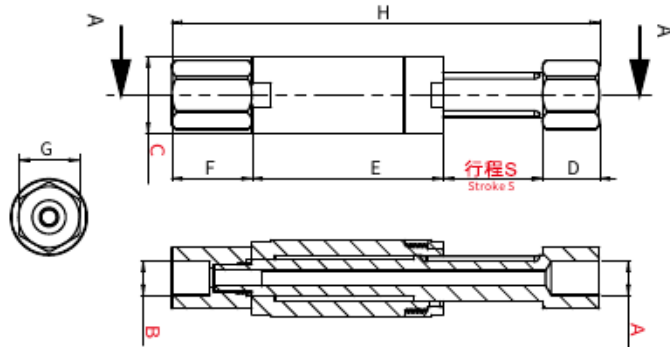

货号(PN)	型号(Model)	A(mm)	B(mm)	C(mm)	D(mm)	E(mm)	F(mm)	G(mm)	H(mm)	S(mm)	重量Weight(g)
8.Y00064	VFNI1011-M5	M5	M5	Ø10	10	22	17	8	60	11	7g
8.Y00321	VFNI1021-M5	M5	M5	Ø10	10	41	17	8	89	21	11g
8.Y00065	VFNI1421-G1/8	G1/8	G1/8	Ø14	12	40	20	12	93	21	24g
8.Y00322	VFNI1436-G1/8	G1/8	G1/8	Ø14	12	60	20	12	128	36	44g
8.Y00066	VFNI2026-G1/8	G1/8	G1/8	Ø20	15	50	21	16	112	26	54g
8.Y00067	VFNI2051-G1/8	G1/8	G1/8	Ø20	15	84	21	16	171	51	80g

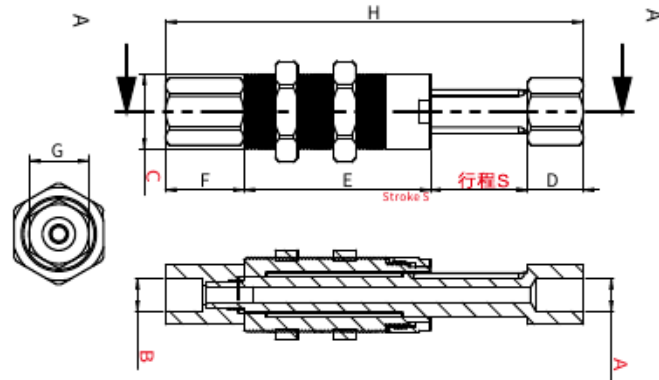

货号(PN)	型号(Model)	A(mm)	B(mm)	C(mm)	D(mm)	E(mm)	F(mm)	G(mm)	H(mm)	S(mm)	重量Weight(g)
8.Y00068	VFNT1011-M5	M5	M5	M10*1	10	22	17	8	60	11	12g
8.Y00323	VFNT1021-M5	M5	M5	M10*1	10	41	17	8	89	21	39g
8.Y00204	VFNT1421-G1/8	G1/8	G1/8	M14*1	12	40	20	12	93	21	51g
8.Y00383	VFNT1621-G1/8	G1/8	G1/8	M16*1	12	40	20	12	93	21	64g
8.Y00324	VFNT1436-G1/8	G1/8	G1/8	M14*1	12	60	20	12	128	36	72g
8.Y00384	VFNT1636-G1/8	G1/8	G1/8	M16*1	12	60	20	12	128	36	76g
8.Y00205	VFNT2026-G1/8	G1/8	G1/8	M20*1	15	50	21	16	112	26	82g
8.Y00206	VFNT2051-G1/8	G1/8	G1/8	M20*1	15	84	21	16	171	51	120g

型材、钢管  
Profile, SUS Tube

支架模组  
Stents Module

快换  
Quick Changer

夹具组件  
Grip Module

气动剪刀  
Air Nipper

真空组件  
Vacuum Module

附件  
Accessory Components

## 可旋转悬件

### Rotative Suspensions

主体和杆由阳极铝制成。  
拥有高负载能力的可旋转杆。  
压力范围：-1 ~ 8 bar。

Body and rod in anodized aluminum.  
Non-rotative rod with high load capability.  
Pressure range: -1 ~ 8 bar.



M5为蓝色  
M5 is blue

G1/8为黑色  
G1/8 is black

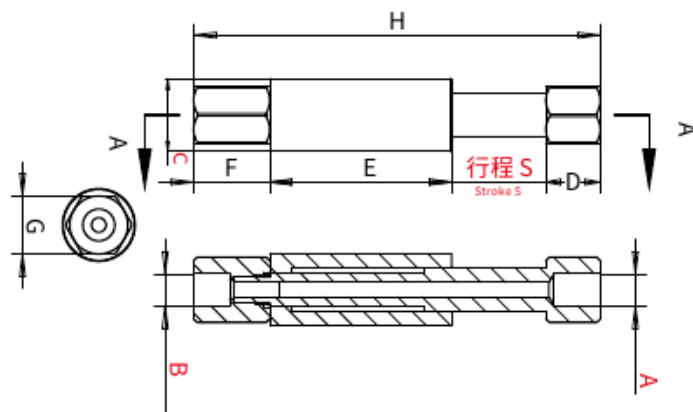

货号(PN)	型号(Model)	A(mm)	B(mm)	C(mm)	D(mm)	E(mm)	F(mm)	G(mm)	H(mm)	S(mm)	重量Weight(g)
8.Y00060	VFR1011-M5	M5	M5	Ø10	3	22	17	8	53	11	12g
8.Y00325	VFR1021-M5	M5	M5	Ø10	3	41	17	8	82	21	17g
8.Y00061	VFR1421-G1/8	G1/8	G1/8	Ø14	12	40	20	12	93	21	23g
8.Y00326	VFR1436-G1/8	G1/8	G1/8	Ø14	12	60	20	12	128	36	40g
8.Y00062	VFR2026-G1/8	G1/8	G1/8	Ø20	15	50	21	16	112	26	50g
8.Y00063	VFR2051-G1/8	G1/8	G1/8	Ø20	15	84	21	16	171	51	77g



M5为蓝色  
M5 is blue

G1/8为黑色  
G1/8 is black

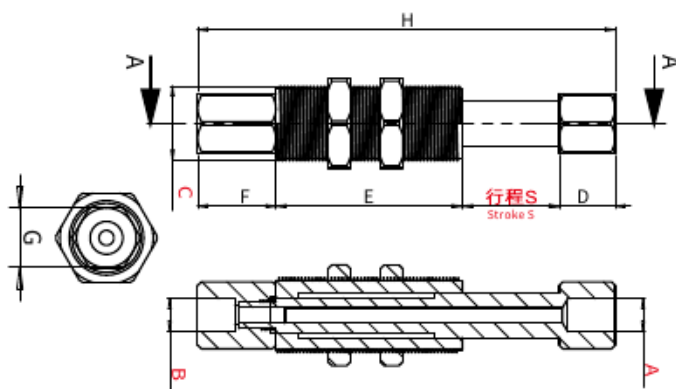

货号(PN)	型号(Model)	A(mm)	B(mm)	C(mm)	D(mm)	E(mm)	F(mm)	G(mm)	H(mm)	S(mm)	重量Weight(g)
8.Y00074	VFRT1011-M5	M5	M5	M10*1	3	22	17	8	53	11	14g
8.Y00327	VFRT1021-M5	M5	M5	M10*1	3	41	17	8	82	21	26g
8.Y00075	VFRT1421-G1/8	G1/8	G1/8	M14*1	12	40	20	12	93	21	32g
8.Y00381	VFRT1621-G1/8	G1/8	G1/8	M16*1	12	40	20	12	93	21	36g
8.Y00328	VFRT1436-G1/8	G1/8	G1/8	M14*1	12	60	20	12	128	36	60g
8.Y00382	VFRT1636-G1/8	G1/8	G1/8	M16*1	12	60	20	12	128	36	65g
8.Y00076	VFRT2026-G1/8	G1/8	G1/8	M20*1	15	50	21	16	112	26	70g
8.Y00077	VFRT2051-G1/8	G1/8	G1/8	M20*1	15	84	21	16	171	51	104g

## 可调节吸盘弯臂

### Adjustable Elbow Arm

在旋转后通气, 可以根据客户不同需求调节不同的角度。  
用于应对一些特殊环境, 与吸盘座和小金具配合使用。

After the rotation of ventilation, according to different customer needs to adjust the different angle.  
Mount this vacuum elbow between the vacuum cup and suspension of the extension tube.



实物包含气管接头  
Physical Includes Air Fittings

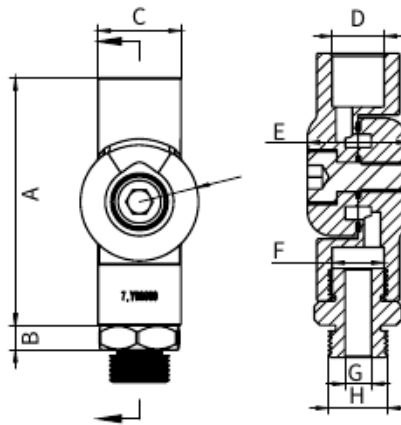

货号(PN)	型号(Model)	A(mm)	B(mm)	C(mm)	D(mm)	E(mm)	F(mm)	G(mm)	H(mm)	重量Weight(g)
7.Y02101	VM-05F05F	33	4.10	Ø10	M5	14	M5	Ø2	G1/8	28g
7.Y02099	VM-18F18F	42	4.10	Ø14	G1/8	17.2	G1/8	Ø4.5	G1/8	53g
7.Y02100	VM-14F14F	56	4.10	Ø15.9	G1/4	18.4	G1/4	Ø5	G1/8	86g

Profile- SUS Tube  
型材、钢管

Stents Module  
支架模组

Quick Changer  
快换

Grip Module  
夹具组件

Air Nipper  
气动剪刀

Vacuum Module  
真空组件

Accessory Components  
附件

## 带集成弯臂的非可旋转悬件

### Non-rotative Suspensions With Integral Elbow Arms

可在 0° 和 +/-90° 之间不断设置角度。  
外部供气。  
主体和杆由阳极铝制成。  
拥有高负载能力的非可旋转杆。  
压力范围: -1 ~ 8 bar。

It is possible to set continuously the angle between 0° and +/-90°.  
External air feeding.  
Body and rod in anodized aluminum.  
Non-rotative rod with high load capability.  
Pressure range: -1 ~ 8 bar.

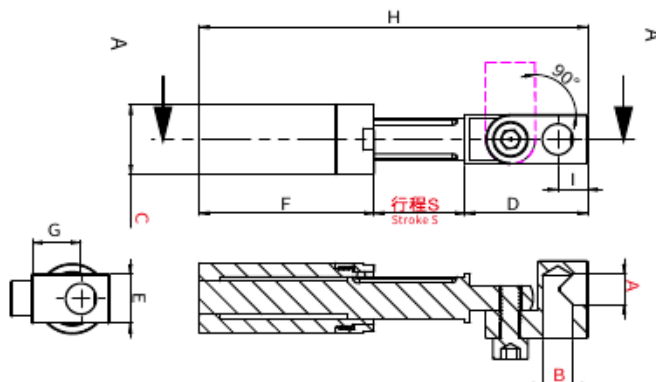

货号(PN)	型号(Model)	A(mm)	B(mm)	C(mm)	D(mm)	E(mm)	F(mm)	G(mm)	H(mm)	S(mm)	重量Weight(g)
8.Y00070	VFE1011-M5	M5	M5	Ø10	20	8	22	8	53	11	12g
8.Y00371	VFE1021-M5	M5	M5	Ø10	20	8	41	8	81	21	16g
8.Y00071	VFE1421-G18	G1/8	G1/8	Ø14	32	14	40	14	93	21	45g
8.Y00372	VFE1436-G18	G1/8	G1/8	Ø14	32	14	60	14	128	36	48g
8.Y00072	VFE2026-G18	G1/8	G1/8	Ø20	35	14	50	14	111	26	70g
8.Y00073	VFE2051-G18	G1/8	G1/8	Ø20	35	14	84	14	169.5	51	105g

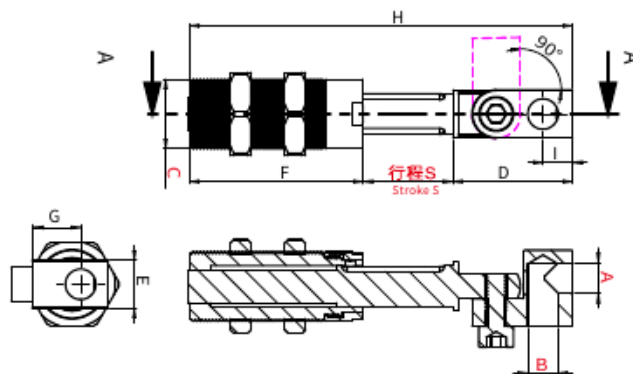

货号(PN)	型号(Model)	A(mm)	B(mm)	C(mm)	D(mm)	E(mm)	F(mm)	G(mm)	H(mm)	S(mm)	重量Weight(g)
8.Y00069	VFET1011-M5	M5	M5	M10*1	20	8	22	8	53	11	15g
8.Y00374	VFET1021-M5	M5	M5	M10*1	20	8	41	8	81	21	24g
8.Y00228	VFET1421-G18	G1/8	G1/8	M14*1	32	14	40	14	93	21	57g
8.Y00379	VFET1621-G18	G1/8	G1/8	M16*1	32	14	40	14	93	21	64g
8.Y00375	VFET1436-G18	G1/8	G1/8	M14*1	32	14	60	14	128	36	80g
8.Y00380	VFET1636-G18	G1/8	G1/8	M16*1	32	14	60	14	128	36	85g
8.Y00229	VFET2026-G18	G1/8	G1/8	M20*1	35	14	50	14	111	26	88g
8.Y00230	VFET2051-G18	G1/8	G1/8	M20*1	35	14	84	14	169.5	51	125g

Profile, SUS Tube  
型材、钢管

Stents Module  
支架模组

Quick Changer  
快换

Grip Module  
夹具组件

Air Nipper  
气动剪刀

Vacuum Module  
真空组件

Accessory Components  
附件

## 配管固定的非可旋转悬件

### Non-rotating Suspension For Fixed Piping

产品采用阳极铝制成。  
内置防转塑料活塞。  
内置伸缩功能弹簧复位，  
尾部真空进气固定式设计。

The product is made of anodic aluminium.  
Built-in anti-rotation plastic piston.  
Built-in telescopic function of spring reset,  
tail vacuum intake fixed design.

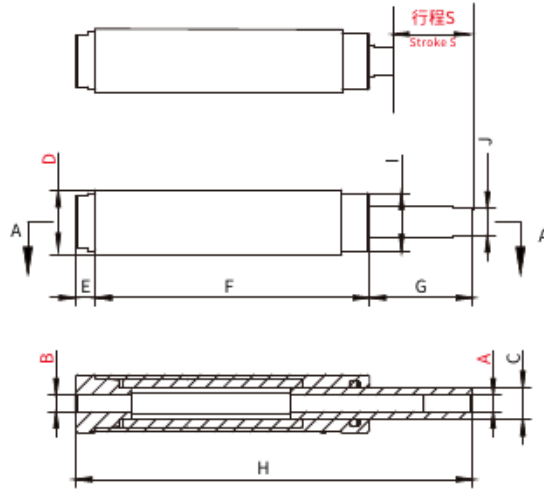

货号(PN)	型号(Model)	A	B	C	D	E	F	G	H	I	J	S	重量Weight(g)
8.Y00313	VFC2030-G18	G1/8	G1/8	Φ13	Φ20	8	85	40	133	Φ18	12	30	60

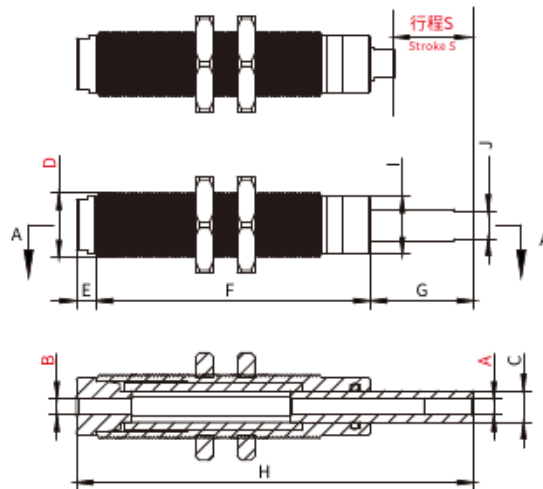

货号(PN)	型号(Model)	A	B	C	D	E	F	G	H	I	J	S	重量Weight(g)
8.Y00277	VFCT1620-M5	M5	M5	Φ8	M16X1.0	5	69	26	100	Φ14.5	7	20	42.7
8.Y00314	VFCT2030-G18	G1/8	G1/8	Φ13	M20X1.0	8	85	40	133	Φ18	12	30	80

型材、钢管  
Profile, SUStube

支架模组  
Stents Module

快换  
Quick Changer

夹具组件  
Grip Module

气动剪刀  
Air Nipper

真空组件  
Vacuum Module

附件  
Accessory Components

# 气动吸附金具

## The Adsorption Of Pneumatic Fittings

Profile, SUS Tube  
型材、钢管

Stents Module  
支架模组

Quick Changer  
快换

Grip Module  
夹具组件

Air Nipper  
气动剪刀

Vacuum Module  
真空组件

Accessory Components  
附件

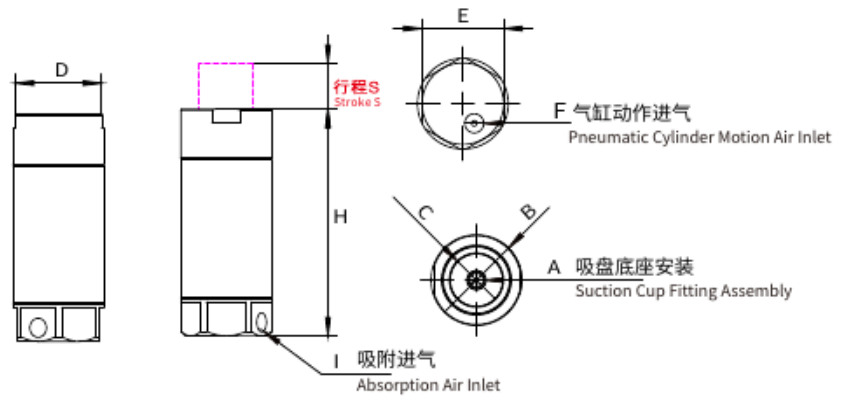

货号(PN)	型号(Model)	A(mm)	B(mm)	C(mm)	D(mm)	E(mm)	F(mm)	H(mm)	I(mm)	S(mm)	重量(Weight)
8.Y00207	VFG20-10	M5	Ø20	Ø12	19	18	M5	50	M5	10	35g
8.Y00337	VFG20-20	M5	Ø20	Ø12	19	18	M5	65	M5	20	45g
8.Y00338	VFG30-20	G1/8	Ø30	Ø20	27	27	G1/8	72	M5	20	70g

# 双动吸附金具

## Double action adsorption fittings

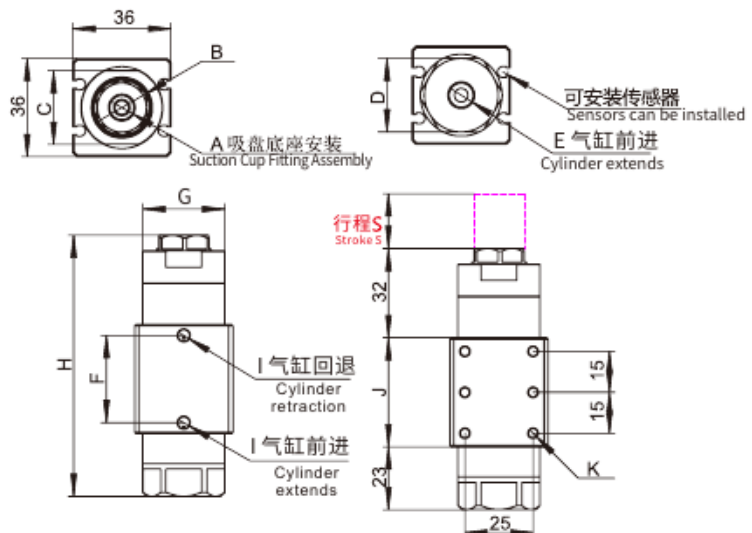

货号(PN)	型号(Model)	A	B	C	D	E	F	G	H	I	J	K	S	重量(Weight)
8.Y00451	VFGD30-20	G1/8	Ø20	27	27	G1/8	32	Ø30	95	M5	40	M4	20	198.2g

### 型号表示方法

Model representation methods

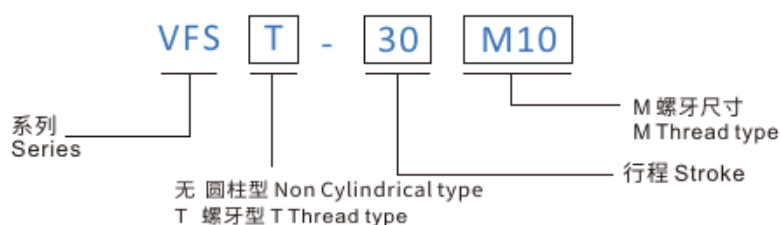

VFST

VFS



VFMT

VFM

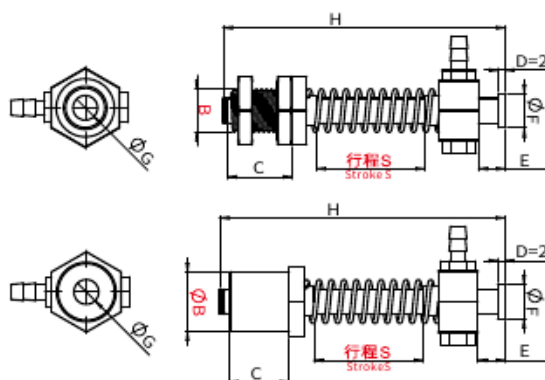

货号(PN)	型号(Model)	B(mm)	C(mm)	E(mm)	F(mm)	G(mm)	H(mm)	S(mm)	重量Weight(g)
8.Y00283	VFST-5M10	M10*1	18	5.5	Ø7	Ø3.4	49	5	14g
8.Y00284	VFST-10M10	M10*1	18	5.5	Ø7	Ø3.4	54	10	15g
8.Y00285	VFST-20M10	M10*1	18	5.5	Ø7	Ø3.4	64	20	15g
8.Y00286	VFST-30M10	M10*1	18	5.5	Ø7	Ø3.4	74	30	16g
8.Y00287	VFS-0508	Ø8	18	5.5	Ø7	Ø3.4	49	5	9g
8.Y00288	VFS-0512	Ø12	18	5.5	Ø7	Ø3.4	49	5	13g
8.Y00289	VFS-1008	Ø8	18	5.5	Ø7	Ø3.4	54	10	9g
8.Y00007	VFS-1012	Ø12	18	5.5	Ø7	Ø3.4	54	10	14g
8.Y00290	VFS-2008	Ø8	18	5.5	Ø7	Ø3.4	64	20	10g
8.Y00008	VFS-2012	Ø12	18	5.5	Ø7	Ø3.4	64	20	14g
8.Y00291	VFS-3008	Ø8	18	5.5	Ø7	Ø3.4	74	30	11g
8.Y00292	VFS-3012	Ø12	18	5.5	Ø7	Ø3.4	74	30	15g
8.Y00293	VFMT-5M12	M12*1	18	9	Ø11	Ø4.6	52.5	5	20g
8.Y00294	VFMT-10M12	M12*1	18	9	Ø11	Ø4.6	57.5	10	21g
8.Y00295	VFMT-20M12	M12*1	18	9	Ø11	Ø4.6	67.5	20	22g
8.Y00296	VFMT-30M12	M12*1	18	9	Ø11	Ø4.6	77.5	30	24g
8.Y00297	VFM-0512	Ø12	18	9	Ø11	Ø4.6	52.5	5	15g
8.Y00298	VFM-0520	Ø20	18	9	Ø11	Ø4.6	52.5	5	29g
8.Y00299	VFM-1012	Ø12	18	9	Ø11	Ø4.6	57.5	10	16g
8.Y00300	VFM-1020	Ø20	18	9	Ø11	Ø4.6	57.5	10	29g
8.Y00301	VFM-2012	Ø12	18	9	Ø11	Ø4.6	67.5	20	18g
8.Y00302	VFM-2020	Ø20	18	9	Ø11	Ø4.6	67.5	20	31g
8.Y00303	VFM-3012	Ø12	18	9	Ø11	Ø4.6	77.5	30	19g
8.Y00304	VFM-3020	Ø20	18	9	Ø11	Ø4.6	77.5	30	32g

# 吸着金具

## Suction Stems

### 型号表示方法

Model representation methods

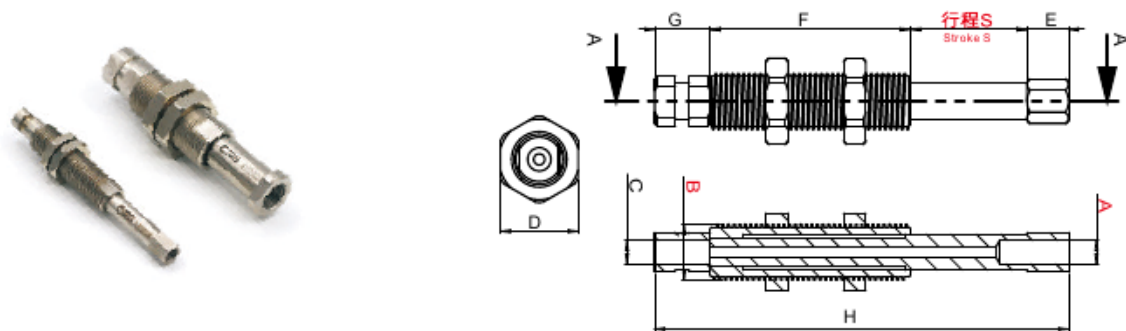
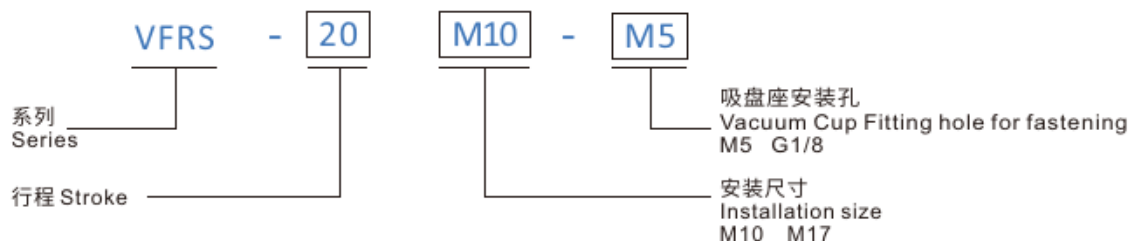

货号(PN)	型号(Model)	A(mm)	B(mm)	C(mm)	D(mm)	E(mm)	F(mm)	G(mm)	H(mm)	S(mm)	重量Weight(g)
4.Y00026	VFRS-20M10-M5	M5	M10*1	M5	14	7	36	10	73.5	20	27g
4.Y00023	VFRS-20M16-G18	G1/8	M16*1	G1/8	21	4	36	15	77	20	76g

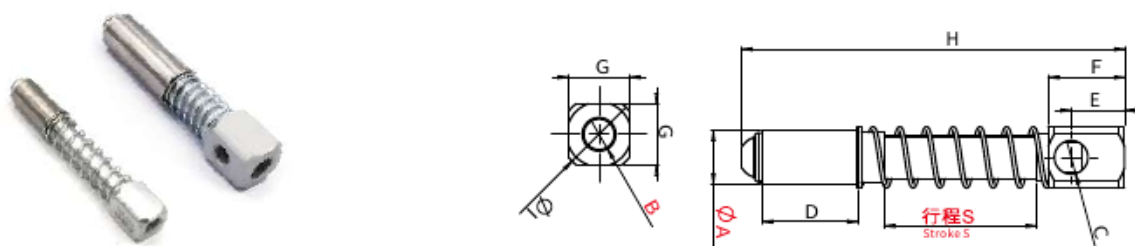

货号(PN)	型号(Model)	A(mm)	B(mm)	C(mm)	D(mm)	E(mm)	F(mm)	G(mm)	H(mm)	I(mm)	S(mm)	重量Weight(g)
1.Y01452	VFM-4014-G18	Ø14	G1/8	G1/8	25	14	20	16	100	Ø20	40	48g
1.Y01451	VFM-2020-G14	Ø20	G1/4	G1/8	48	15	26	22	113	Ø27	20	136g

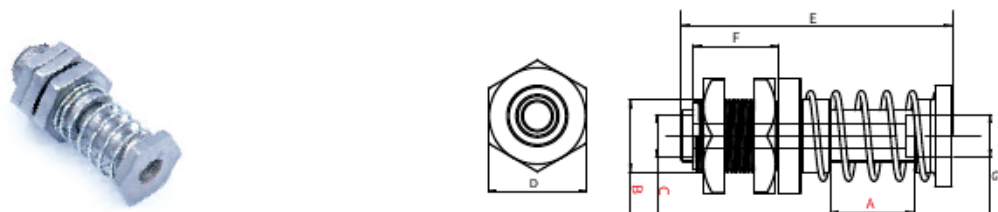

货号(PN)	型号(Model)	A(mm)	B(mm)	C(mm)	D(mm)	E(mm)	F(mm)	G(mm)	重量Weight(g)
1.Y01453	VFL-20M17-G18	20	M17*1	G1/8	27	64	20	G1/8	119g

# 吸着金具

## Suction Stems

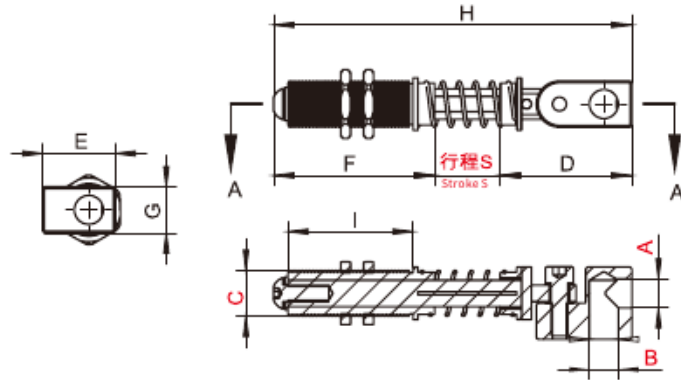

货号(PN)	型号(Model)	A(mm)	B(mm)	C(mm)	D(mm)	E(mm)	F(mm)	G(mm)	H(mm)	I(mm)	S(mm)	重量Weight(g)
8.Y00319	VFMT-20M14-G18	G1/8	G1/8	M14X1.0	40	22	49	14	109	38	20	97g
8.Y00320	VFMT-40M14-G18	G1/8	G1/8	M14X1.0	40	22	64	14	144	50	40	123g

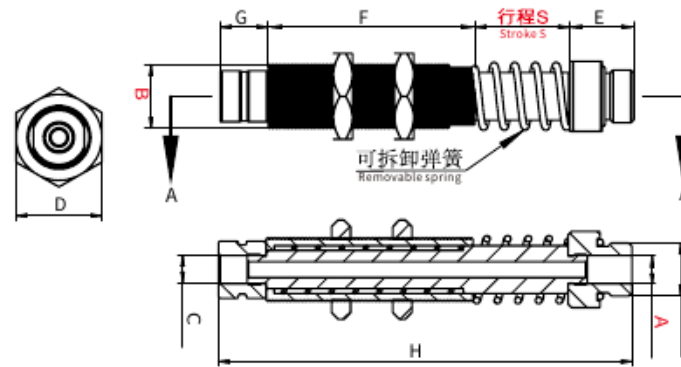

货号(PN)	型号(Model)	A(mm)	B(mm)	C(mm)	D(mm)	E(mm)	F(mm)	G(mm)	H(mm)	I(mm)	S(mm)	重量Weight(g)
8.Y00409	VFHT-30M20-G38F-G18M	G1/8	M20*1	G1/8	27	20	65	15	130	G3/8	30	260g

\*安装单弹簧时,所能承受的压力为7N-18N。安装双弹簧时,所能承受的压力为60N-150N

\*When installing a single spring, the pressure it can bear is 7N-18N. When installing the double spring, the pressure that can bear is 60N-150N.

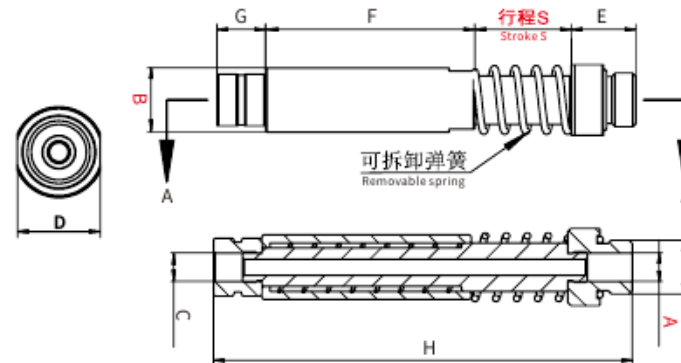

货号(PN)	型号(Model)	A(mm)	B(mm)	C(mm)	D(mm)	E(mm)	F(mm)	G(mm)	H(mm)	I(mm)	S(mm)	重量Weight(g)
8.Y00410	VFH-30M20-G38F-G18M	G1/8	Ø20	G1/8	22	20	65	15	130	G3/8	30	235g

\*安装单弹簧时,所能承受的压力为7N-18N。安装双弹簧时,所能承受的压力为60N-150N

\*When installing a single spring, the pressure it can bear is 7N-18N. When installing the double spring, the pressure that can bear is 60N-150N.

Profile- SUS Tube  
型材、钢管

Stents Module  
支架模组

Quick Changer  
快换

Grip Module  
夹具组件

Air Nipper  
气动剪刀

Vacuum Module  
真空组件

Accessory Components  
附件

# 吸着金具

## Suction Stems

### 型号表示方法

#### Model representation methods

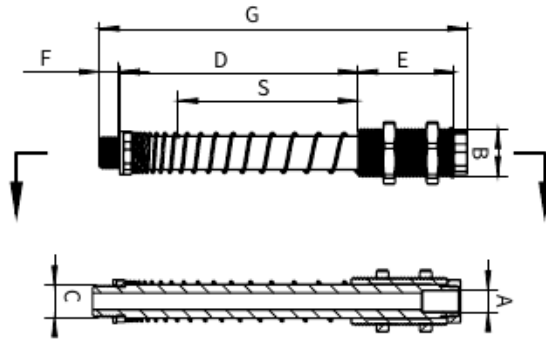
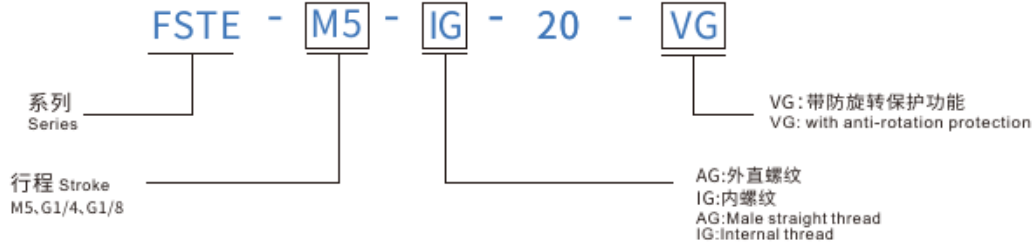

货号(PN)	型号(Model)	A(mm)	B(mm)	C(mm)	D(mm)	E(mm)	F(mm)	G(mm)	S(mm)	重量Weight(g)
8.Y01113	FSTE-G14-AG-75	G1/8	M20*1.5	G1/4	99.3	40	8.5	153.3	75	180g
8.Y01112	FSTE-G18-AG-25	G1/8	M16*1	G1/8	43	30	6	93	25	93g

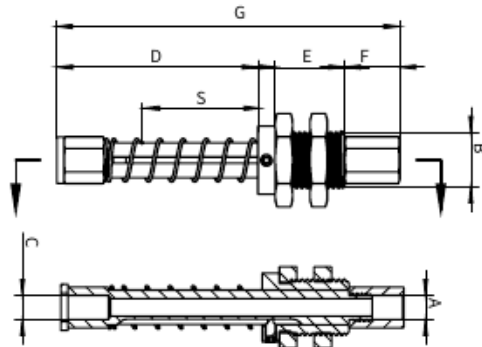

货号(PN)	型号(Model)	A(mm)	B(mm)	C(mm)	D(mm)	E(mm)	F(mm)	G(mm)	S(mm)	重量Weight(g)
8.Y01111	FSTE-M5-IG-20-VG	M5	G1/8	M5	35	12	9.5	59.2	20	21g

Profile, SUS Tube  
型材、钢管

Stents Module  
支架模组

Quick Changer  
快换

Grip Module  
夹具组件

Air Nipper  
气动剪刀

Vacuum Module  
真空组件

Accessory Components  
附件

# 电磁阀

## Solenoid Valve

SY5120-5LZD-01

单头Single head

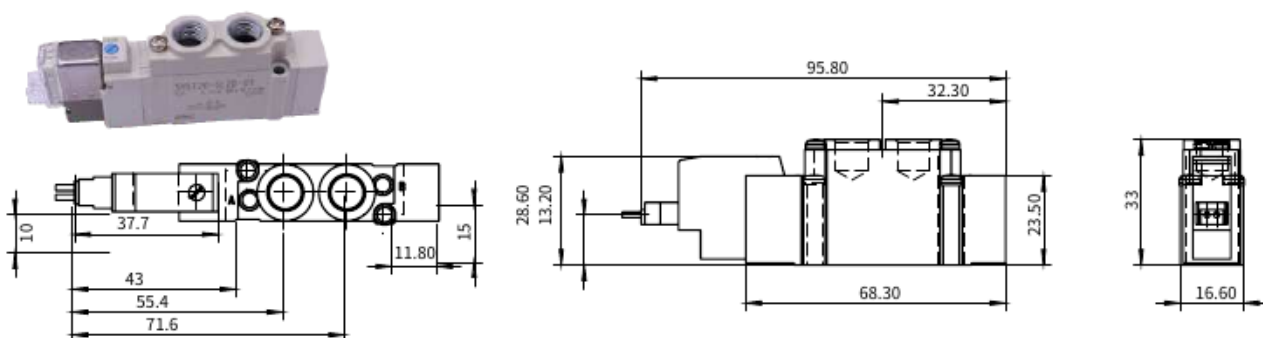

SY5220-5LZD-01

两位五通双头Two-position five-way double head

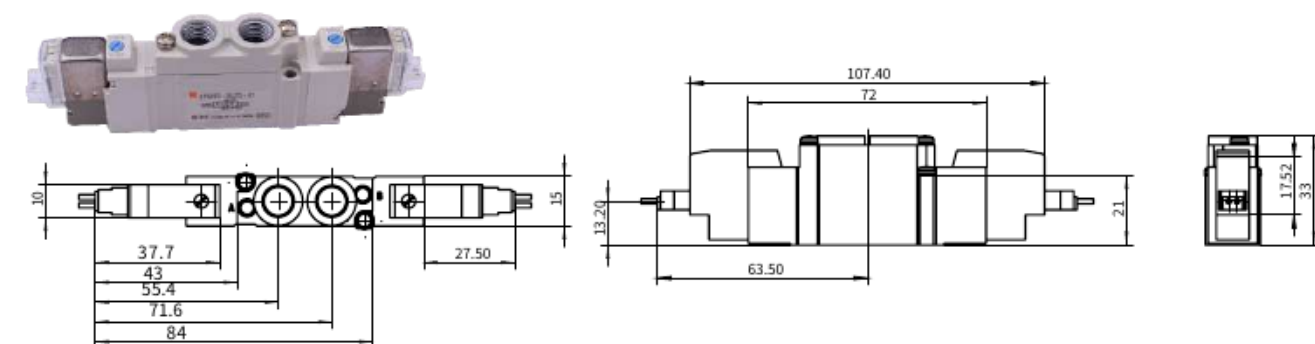

SY5320-5LZD-01

三位五通双头Three-position five-way double head

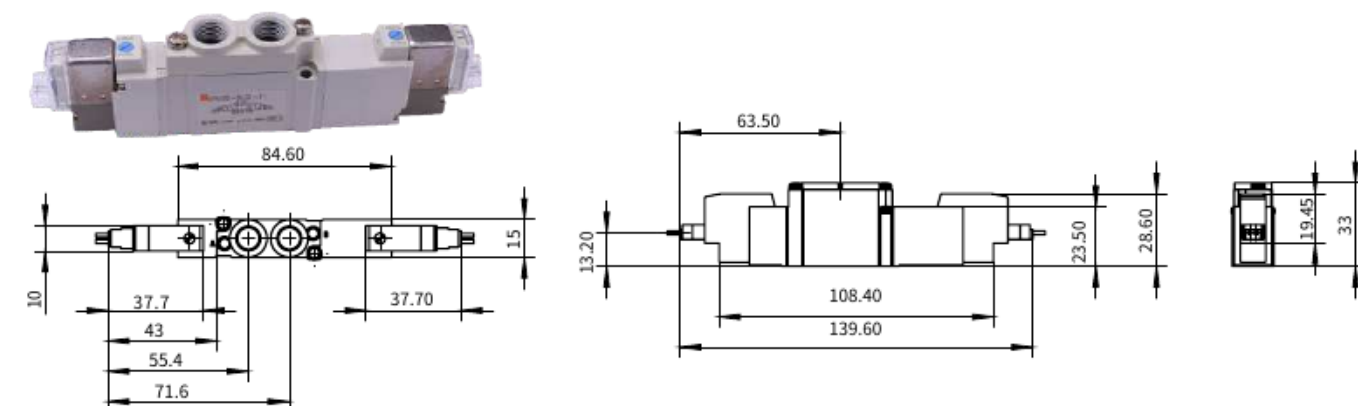

货号(PN)	1.Y02556	1.Y02557	1.Y02747
型号(Nodel)	SY5120-5LZD-01	SY5220-5LZD-01	SY5320-5LZD-01
机能Actuation	2位单电控 2-position single electric control	2位双电控 2-position dual electric control	3位中位封闭式 3-position centre closed
重量 Weight	71g	86g	94g
线圈规格Coil	标准型 Standard type		
额定电压Voltage	DC24V		
导线引出方式Entry	L形插座式, 导线长300mm L-shaped socket type, conductor length 300mm		
指示灯, 过电压保护回路Suppressor	带指示灯/过电压保护回路 With indicator/overvoltage protection circuit		
手动操作Manual	旋具压下回转锁定式 Spinner press down rotary locking type		
A,B通孔接管口径Absize	1/8		
螺纹类型Thread	Rc		

Profile- SUS Tube

Stents Module

Quick Changer

Grip Module

Air Nipper

Vacuum Module

Accessory Components

# 电磁阀底座 Solenoid Valve Base

Profile, SUS Tube  
型材、钢管

Stentis Module  
支架模组

Quick Changer  
快换

Grip Module  
夹具组件

Air Nipper  
气动剪刀

Vacuum Module  
真空组件

Accessory Components  
附件

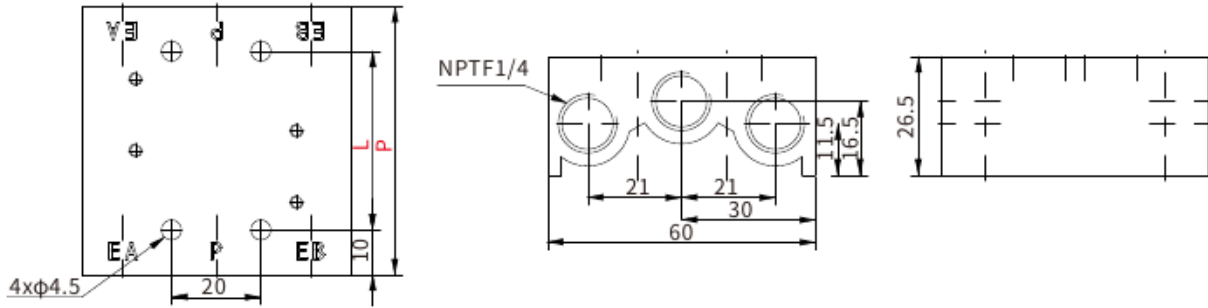

货号(PN)	1.Y02609	1.Y02610	1.Y02611	1.Y02612	1.Y02613	1.Y02614	1.Y02615	1.Y02616	1.Y02617	
型号(Model)	SS5Y5-20-2	SS5Y5-20-3	SS5Y5-20-4	SS5Y5-20-5	SS5Y5-20-6	SS5Y5-20-7	SS5Y5-20-8	SS5Y5-20-9	SS5Y5-20-10	
连数(Row)	2	3	4	5	6	7	8	9	10	
L	40	56	72	88	104	120	136	152	168	
P	60	66	92	108	124	140	156	172	188	
货号(PN)	1.Y02618	1.Y02619	1.Y02620	1.Y02621	1.Y02622	1.Y02623	1.Y02624	1.Y02625	1.Y02626	1.Y02627
型号(Model)	SS5Y5-20-11	SS5Y5-20-12	SS5Y5-20-13	SS5Y5-20-14	SS5Y5-20-15	SS5Y5-20-16	SS5Y5-20-17	SS5Y5-20-18	SS5Y5-20-19	SS5Y5-20-20
连数(Row)	11	12	13	14	15	16	17	18	19	20
L	184	200	216	232	248	264	280	296	312	328
P	204	220	236	252	268	284	300	316	332	348

# Compact 10CE 集成式真空发生器

## Compact 10CE Integrated Vacuum Generator

数据表所指定的数值可进行测试：

- 室温 (20°C [68°F] ± 3°C [5.5°F])。
- 标准大气压 (101.3 [29.9 inHg] ± 1.0 Kpa [0.3 inHg])。
- 相对湿度：35-85%，无冷凝。
- 压缩空气质量，DIN ISO 8573-1 class 4 标准。

Values specified in the data sheet are tested at:

- Room temperature (20°C [68°F] ± 3°C [5.5°F])
- Standard atmosphere (101.3 [29.9 inHg] ± 1.0 kPa [0.3 inHg])
- Relative humidity: 35-85%, non condensation
- Compressed air quality DIN ISO 8573-1 class 4 standard

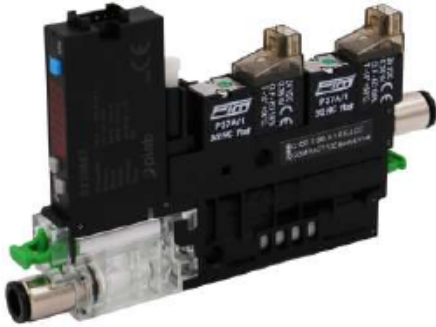

\*连接线材长为两米 The wire's length is 2 meters

货号 (PN)	型号 (Model)	类型 (Type)
1.Y13064	COMPACT10E PNP	PNP
1.Y13279	COMPACT10E NPN	NPN

### 气路图

Gas circuit diagram

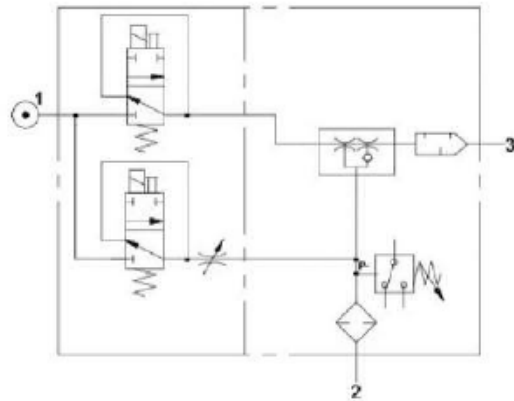

说明 Description	单位 Unit	值 Value
推荐进气压力 Recommended feed pressure	Mpa	0.5
最大进气压力 Feed pressure, max.	Mpa	0.7
温度范围 Temperature range	°C	0-50
重量* Weight*	g	74
材料 Material	-	PA, AL, CuZn, PE, NBR, PC, SS, TPV, FKM, Steel, Glass epoxy
1-8 个真空通道条件下的噪音等级范围 Noise level range of 1-8 vacuum channels	dB	46-60
连接, 压缩空气 Connection, compressed air	-	ø6 推入式连接器 ø6 push-in connector
连接, 真空 Connection, vacuum	-	ø6 推入式连接器 ø6 push-in connector

\*) 注意! 重量不包括运输中包含的电缆。\*) Note! The weight does not include the cables that are included in the shipping.

Profile- SUS Tube  
型材、钢管

Stents Module  
支架模组

Quick Changer  
快换

Grip Module  
夹具组件

Air Nipper  
气动剪刀

Vacuum Module  
真空组件

Accessory Components  
附件

# Compact 10CE 集成式真空发生器

## Compact 10CE Integrated Vacuum Generator

Profile, SUS Tube  
型材、钢管

Stentis Module  
支架模组

Quick Changer  
快换

Grip Module  
夹具组件

Air Nipper  
气动剪刀

Vacuum Module  
真空组件

Accessory Components  
附件

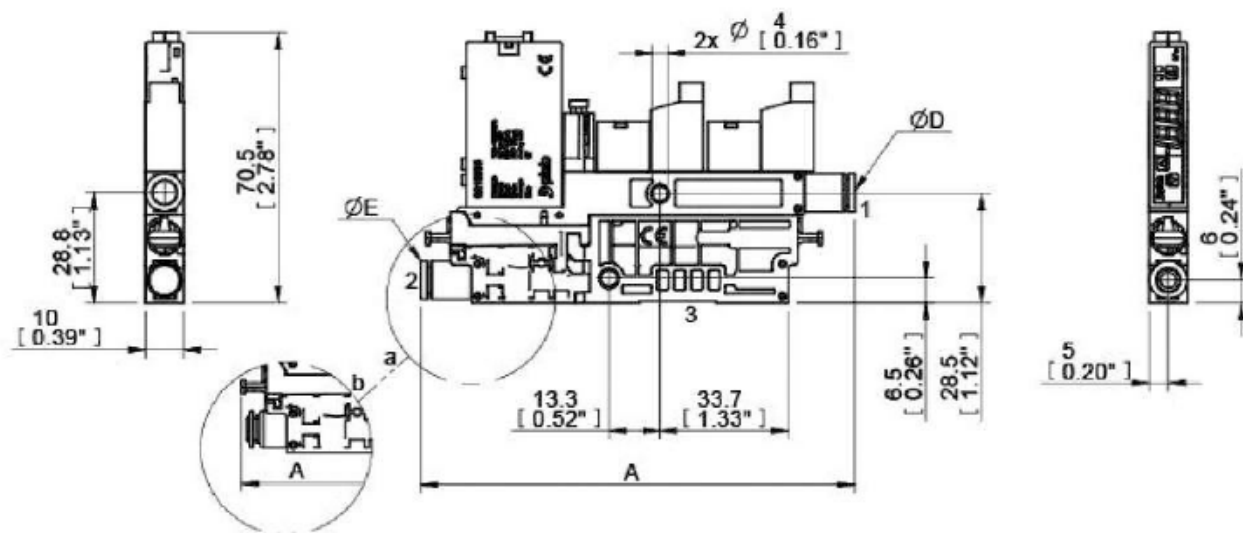

说明 Description	单位 Unit	值 Value
A	mm	113.6
ΦD	mm	Φ6
ΦE	mm	Φ6

配置 Configuration	值 Value
a	ø6 推入式连接器 ø6 push-in connector

### 真空流量

#### Vacuum flow

供气压力真空泵/喷嘴 Feed pressure vacuum pump/nozzle	每个泵/喷嘴的空气消耗量 Air consumption per pump /nozzle	不同真空度 (-kPa) 下的真空流量 (NI/s) Vacuum flow (NI/s) under different vacuum degrees (-kPa)									最大真空度 Max vacuum
		0	10	20	30	40	50	60	70		
Mpa	NI/s	0.26	0.24	0.19	0.14	0.088	0.063	0.045	0.023	-kpa	
0.50/0.40	0.23	0.26	0.24	0.19	0.14	0.088	0.063	0.045	0.023	84	

### 抽真空时间

#### Vacuum time

供气压力真空泵/喷嘴 Feed pressure vacuum pump/nozzle	每个泵/喷嘴的空气消耗量 Air consumption per pump /nozzle	达到不同真空度 (-kPa) 的抽气时间 Pumping time to different vacuum (- kPa)									最大真空度 Max vacuum
		10	20	30	40	50	60	70	80		
Mpa	NI/s	0.40	0.87	1.49	2.38	3.71	5.57	8.52	15.44	-kpa	
0.50/0.40	0.23	0.40	0.87	1.49	2.38	3.71	5.57	8.52	15.44	84	

# Compact 10CE 集成式真空发生器

## Compact 10CE Integrated Vacuum Generator

### 阀门模块

#### Valve module

说明 Description	单位 Unit	值 Value
阀门功能 Valve function	-	NC 真空常闭 + NC 吹气常闭 NC vacuum normally closed + NC blowing normally closed
电源电压 Supply voltage	VDC	24 (21.6 – 26.4)
功率 Power	W	3.5
响应时间 Response time	ms	≤ 3
电气连接 Electrical connection	-	Supplied cable, Red (+) Black (-)

### 真空传感器

#### Vacuum sensor

说明 Description	单位 Unit	值 Value
电源电压 Supply voltage	VDC	12-24 ±10%, 波动 P-P 10% 或更低 12-24 ±10%, Fluctuation P-P 10% or less
电流消耗(无负载) Current consumption (with no load)	mA	≤ 40
切换输出 Switch output	-	NPN
响应时间 Response time	ms	≤ 2,5
模拟输出 Analog output	VDC	1-5 ±2.5% F.S.
电气连接 Electrical connection	-	JST PAP-05V

### 订购信息

#### Ordering information

说明 Description	产品代码 Product code
COMPACT10CE, 超高真空流量 (micro), 显示屏, 模拟和数字输出, NPN, Ø6 推入式连接器, 1 通道, Ø6 推入式连接器, 集成式消音器, NC 真空常闭 + NC 吹气常闭 COMPACT10E, ultra high vacuum flow (micro), display screen, analog and digital output, NPN, Ø6 push in connector, 1 channel, Ø6 push in connector, integrated muffler, NC vacuum normally closed + NC blowing normally closed	C10E.T.BB.6.1.6.EJ.CC

Profile- SUStube  
型材、钢管

Stents Module  
支架模组

Quick Changer  
快换

Grip Module  
夹具组件

Air Nipper  
气动剪刀

Vacuum Module  
真空组件

Accessory Components  
附件

# Compact 20CE 真空发生器

## Compact 20CE Vacuum Generator

### 真空发生器 Vacuum Generator

- 配置Piab 多级真空发生器

Configure Piab multistage vacuum generator

### 阀 valve

- 真空阀和吹气阀

Integrated electric vacuum and blow-off valve

- 吹气流量调节阀

Blowing flow control valve

### 快插接头 Quick connector

- 可配置8mm或者10mm的快插接头。

8mm or 10mm quick connector can be configured.

### 真空传感器 Vacuum sensor

- 可选配具有用户友好型界面的真空传感器，或者选配预留真空检测端口。

Vacuum sensor with user-friendly interface or reserved vacuum detection port is optional.

### 模块式设计 Modular design

- 多级真空发生器可拆卸清洗和更换，故障排除更加简单。

The multistage vacuum generator can be disassembled, cleaned and replaced, and the troubleshooting is simpler.



\*连接线材长为两米 The wire's length is 2 meters

货号(PN)	型号(Model)	类型(Type)
1.Y13062	COMPACT 20CE PNP	PNP
1.Y13063	COMPACT 20CE NPN	NPN

## Compact 20CE 技术参数

### Compact 20CE technical Data

真空技术 Vacuum technology	多级真空发生器 Multistage vacuum generator
工作气源压力 (Mpa) Working air pressure	0.38~0.6
最大真空流量 (NL/S) Maximum Vacuum flow	2.4
最高真空度 (-Kpa) Maximum Vacuum level	84
耗气量 (NL/S) Air consumption	1.5~2.2
工作温度 (°C) Working temperature	-5~50
尺寸 (mm) Size	94x78x30
噪音 (dBA) Noise level	57-68
真空口尺寸 Vacuum port size	G3/8"
净重 (g) Net Weight	370
真空传感器 Vacuum Sensor	PNP/NPN
电磁阀 Solenoid Valve	NC/NO
消耗功率 Power consumption	24V±10% VDC, 2W

# Compact 20CE 真空发生器

## Compact 20CE Vacuum Generator

### Compact 20CE 真空发生器和传感器尺寸图

Dimensional drawing of Compact 20CE Vacuum Generator and Sensor

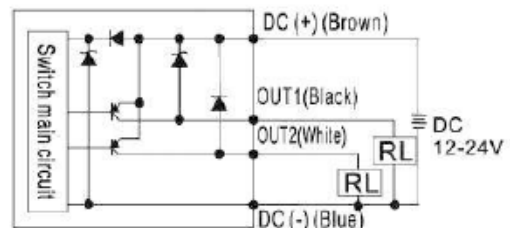
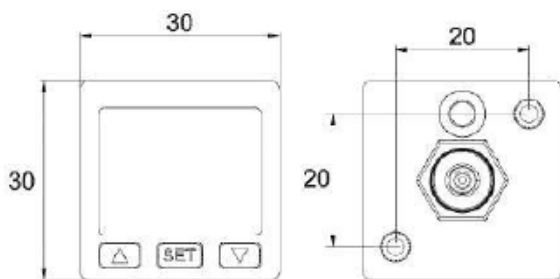
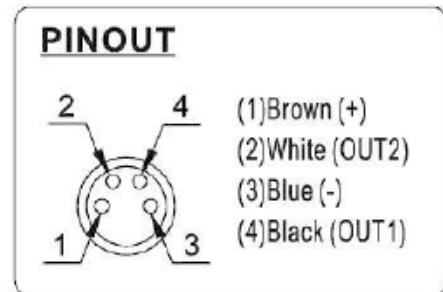
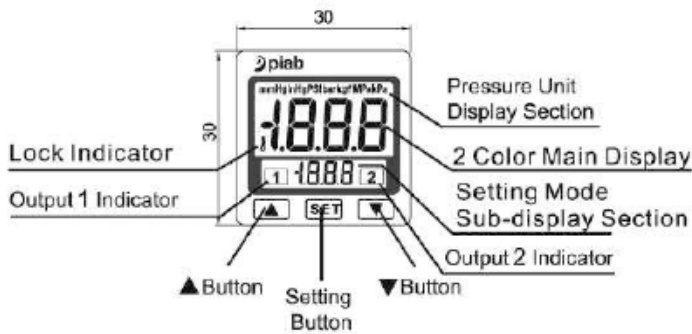
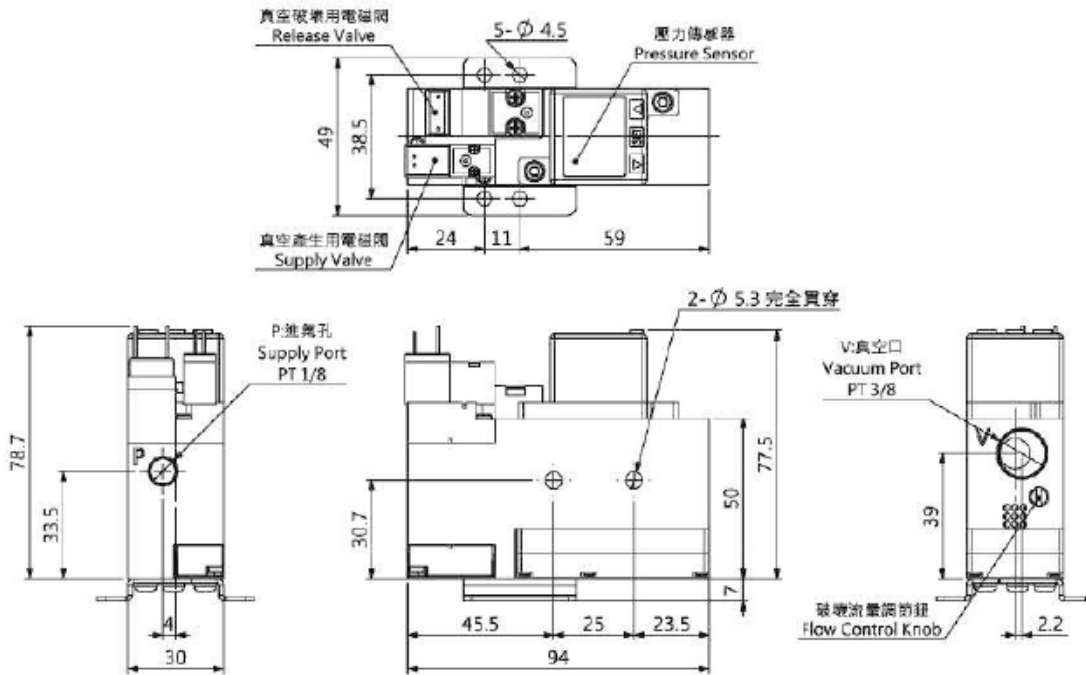

Profile- SUS Tube  
型材、钢管

Stents Module  
支架模组

Quick Changer  
快换

Grip Module  
夹具组件

Air Nipper  
气动剪刀

Vacuum Module  
真空组件

Accessory Components  
附件

# VLCLASSIC XI x 2 真空发生器

## VLCLASSIC XI x 2 Vacuum Generator

Profile, SUS Tube  
型材、钢管

Stents Module  
支架模组

Quick Changer  
快换

Grip Module  
夹具组件

Air Nipper  
气动剪刀

Vacuum Module  
真空组件

Accessory Components  
附件



货号(PN)	型号(Model)
1.Y13065	VLCLASSIC XI x 2

高效节能发生器技术。

真空发生管可在高达 95 -kPa 的真空度下提供高流量。

适用于需高真空度的无渗透应用。

大容量范围, 可提供 1 至 6 个真空发生管。如有需要, VLCLASSIC

可以由较小的容量很轻松的升级为更大容量。

轻巧、可配置的和模块化设计。

易于拆卸维护。

High efficiency and energy saving generator technology.

The vacuum generating tube can provide high flow rate under the vacuum degree up to 95 - kPa.

Suitable for non permeable applications requiring high vacuum.

Large capacity range, 1 to 6 vacuum tubes can be provided. If necessary, vlclassic can be easily upgraded from smaller capacity to larger capacity.

Lightweight, configurable and modular design.

Easy to disassemble and maintain.

### 概述/Summary

物料 Materiel	CuZn, NBR (FKM), PA, SS, Al
噪音 Noise level	64-69 dBA
温度范围 Temperature	-10-80 °C
重量 Weight	550 g
消音器重量 Muffler weight	120 g

### 性能/Performance

最大进气压力 Feed pressure, max.	0.7 MPa
最佳进气压力 Feed pressure, optimum	0.45 MPa
最大真空度 Max vacuum	95 -kPa

### 气动参数/Aerodynamic parameters

内部容积 Internal volume	140 cm <sup>3</sup>
----------------------	---------------------

### 真空流量/Vacuum flow (NI/s)

进气压力 Feed pressure	耗气量 Gas consumption	真空流量 (NI/s) @真空度 (-kPa) Vacuum flow(NI/s) @ vacuum (- kPa)										最大真空度 Max vacuum
		0	10	20	30	40	50	60	70	80	90	
Mpa	NI/s	0	10	20	30	40	50	60	70	80	90	-kPa
0.45	3.66	11.8	6	4	2.6	1.46	1.16	0.86	0.64	0.36	0.06	95

### 排气时间/Exhaust time (s/l)

进气压力 Feed pressure	耗气量 Gas consumption	排气时间 (s/l) 真空度 (-kPa) Exhaust time (s / L) Vacuum (- kPa)									最大真空度 Max vacuum
		10	20	30	40	50	60	70	80	90	
Mpa	NI/s	10	20	30	40	50	60	70	80	90	-kPa
0.45	3.66	0.011	0.031	0.06	0.11	0.19	0.29	0.42	0.6	1.1	95

### 数据表所指明的数值可进行测试:

The values indicated in the data sheet can be tested:

室温 Room temperature	(20°C [68°F] ± 3°C [5.5°F])
标准大气压 Standard atmosphere	(101.3 [29.9 inHg] ± 1.0 kPa [0.3 inHg])
相对湿度 Relative humidity	0-100%
压缩空气质量 Compressed air quality	DIN ISO 8573-1 class 4

# PiINLINE® Vacuum Generator MINI Si 真空发生器

PiINLINE® Vacuum Generator MINI Si Vacuum Generator



- 获得专利的COAX®盒式磁带技术。
- 与能耗相关的高真空流量。
- 低重量内联设计, 带有用于真空和压缩空气的推入式配件。
- 直接在软管上快速方便地安装。
- 用于额外真空流的Si滤筒。
- 用于在低进料压力下实现高性能的Pi滤。
- 需要高流量和深真空时的Xi滤筒。
- Patented COAX® cartridge technology.
- High vacuum flow capacity in relation to energy consumption.
- Low weight inline design with push-in fittings for vacuum and compressed air.
- Quick and easy installation directly on the hose.
- Si cartridge for extra vacuum flow.
- Pi cartridge for high performance at low feed pressures.
- Xi cartridge when high flow and deep vacuum is needed.

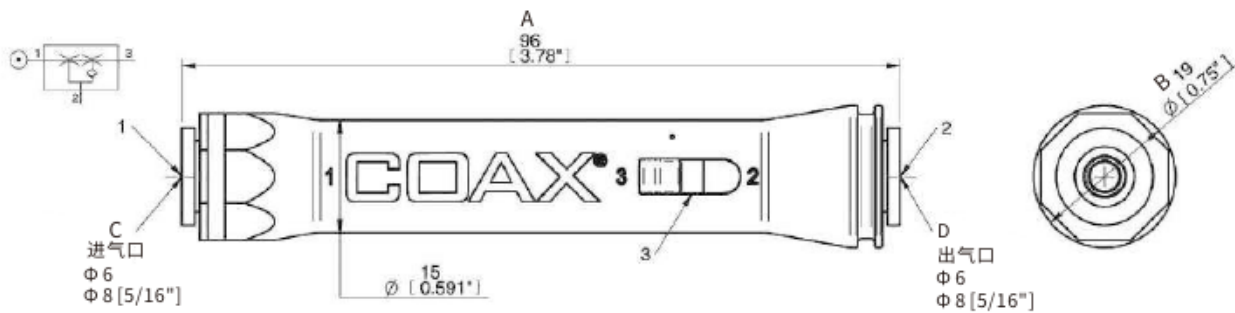

型号 (Model)	PiINLINE® vacuum generator MINI Si, 6-6 mm	PiINLINE® vacuum generator MINI Si, 8-8 mm
货号 (PN)	1.Y13066	1.Y13067
直径 Diameter	19 mm (B)	19 mm (B)
进气口直径 Air inlet diameter	6 mm (C)	8 mm (C)
出气口直径 Air outlet diameter	6 mm (D)	8 mm (D)
长度 Length	96 mm (A)	96 mm (A)

产品编号 (备选) Product number (optional)	E12842188
物料 Material	CuZn, PA, SS, 丁腈橡胶
重量 Weight	21.8 g

耗气量 Gas consumption	25.7 l/m (.9 scfm) NI/s
最大进气压力 Feed pressure, max.	0.7 MPa

型材、钢管  
Profile, SUS Tube

支架模组  
Stents Module

快换  
Quick Changer

夹具组件  
Grip Module

气动剪刀  
Air Nipper

真空组件  
Vacuum Module

附件  
Accessory Components

# PiINLINE® Vacuum Generator MINI Si 真空发生器

PiINLINE® Vacuum Generator MINI Si Vacuum Generator

## 真空流量

Vacuum flow(Nl/s)

进气压力 Feed pressure	耗气量 Gas consumption	真空流量 (Nl/s) @真空度 (-kPa) Vacuum flow(Nl/s) @ vacuum (- kPa)								最大真空度 Max vacuum
Mpa	Nl/s	0	10	20	30	40	50	60	70	-kPa
0.6	0.44	0.69	0.55	0.42	0.28	0.23	0.16	0.12	0.08	75

## 排气时间

Exhaust time (s/l)

进气压力 Feed pressure	耗气量 Gas consumption	排气时间 (s/l) 真空度 (-kPa) Exhaust time (s / L) Vacuum (- kPa)							最大真空度 Max vacuum
Mpa	Nl/s	10	20	30	40	50	60	70	-kPa
0.6	0.44	0.16	0.37	0.66	1.1	1.4	2.1	3.1	75

## 数据表所指明的数值可进行测试：

The values indicated in the data sheet can be tested:

室温 Room temperature	(20°C [68°F] ± 3°C [5.5°F])
标准大气压 Standard atmosphere	(101.3 [29.9 inHg] ± 1.0 kPa [0.3 inHg])
相对湿度 Relative humidity	0-100%
压缩空气品质 Compressed air quality	DIN ISO 8573-1 class 4

# 真空模组 SCPSb系列

## Vacuum Module SCPSb Series

体型轻巧的集成式真空发生器采用高效eco nozzle技术,适用于空间局限下的工况。

The compact and lightweight integrated vacuum generator adopts high-efficiency eco nozzle technology, which is suitable for working conditions under limited space.

### 亮点 Highlights

- 高效eco nozzle技术
- 体积小巧,材质为极其耐用的塑料
- 最佳流体结构,以高效产生真空
- 快插式接口
- 可供DIN标导轨连接的连接口
- 开放式消音器
- Efficient eco nozzle technology
- Small size, made of extremely durable plastic
- Optimal fluid structure for efficient vacuum generation
- Quick-plug interface
- Connecting port for DIN standard rail connection
- Open silencer



\*连接线材长为五米 The wire's length is 5 meters

### 优势 Advantage

- 压缩空气消耗量极少,抽吸速率更高
- 装置小巧耐用;可直接安装在搬运系统上
- 动作周期极短,频率高
- 无需额外螺丝
- 安装简单;也可直接安装于配电箱上
- 噪声低,维护时间间隔长,维护频率低
- The compressed air consumption is very small, and the suction rate is higher
- The device is small and durable; it can be directly installed on the handling system
- The action cycle is extremely short, the frequency is high
- No extra screws required
- Simple installation; can also be installed directly on the distribution box
- Low noise, long maintenance interval, low maintenance frequency

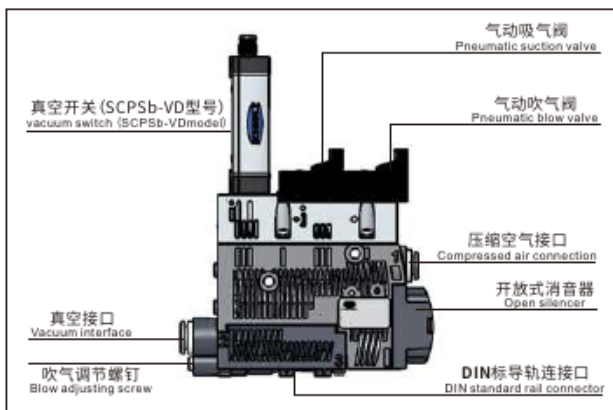
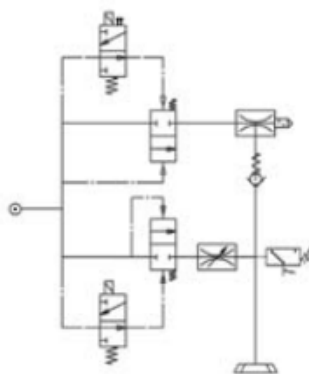

集成式真空发生器SCPSb-VD采用系统化设计  
The integrated vacuum generator SCPSb-VD adopts a systematic design.

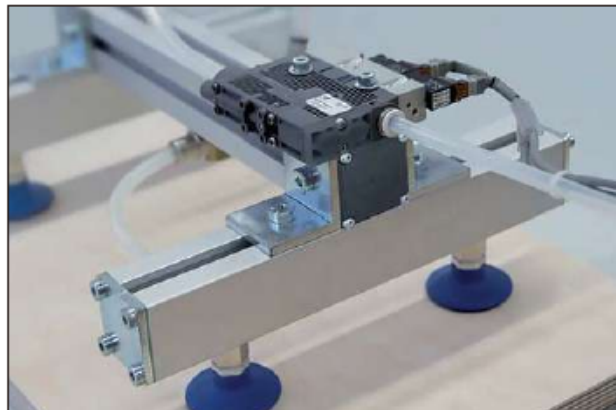

通过集成式真空发生器SCPSb可中央式供给真空  
Vacuum can be supplied centrally through the integrated vacuum generator SCPSb.

型材、钢管  
Profile, SUS Tube

支架模组  
Stents Module

快换  
Quick Changer

夹具组件  
Grip Module

气动剪刀  
Air Nipper

真空组件  
Vacuum Module

附件  
Accessory Components

# 真空模组 SCPSb系列

## Vacuum Module SCPSb Series

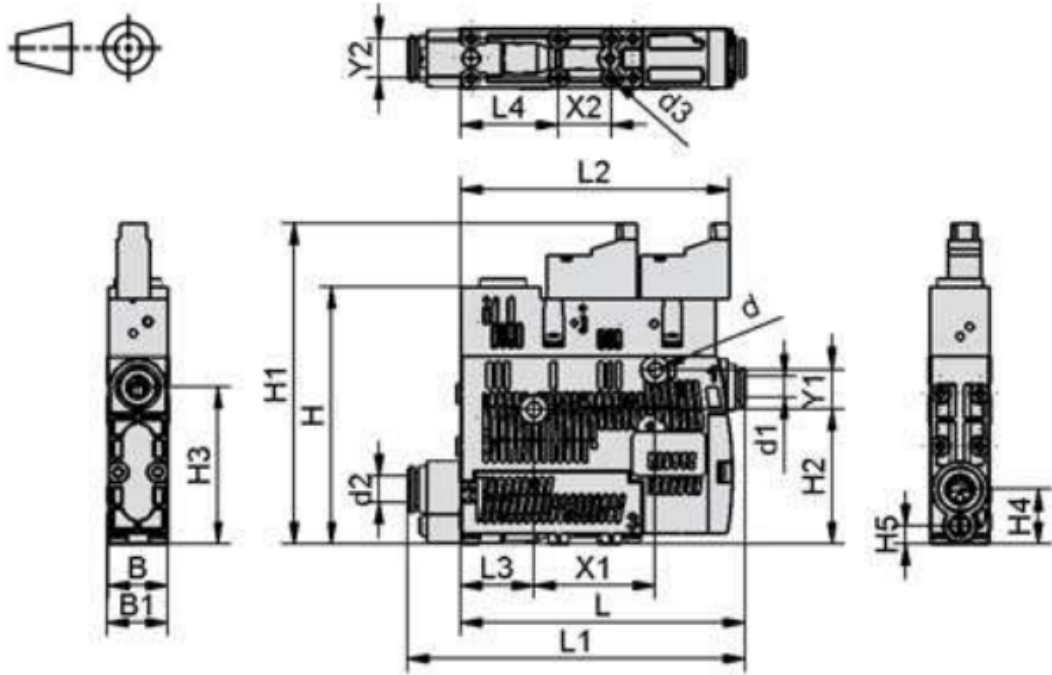

货号 (PN)	型号 (Model)	B	B1	d	d1	d2	d3	H	H1	H2	H3	H4	H5	L	L1	L2	L3	L4	X1	X2	Y1	Y2
1.Y13276	SCPSb-07-S04-NC-VD	18	18.6	4.4	6	6	2.6	77.5	147	40.8	47.5	16.5	5.5	86.2	102.5	81.4	22	29.5	36.9	16	12	12
1.Y13277	SCPSb-10-S04-NC-VD	18	18.6	4.4	6	6	2.6	77.5	147	40.8	47.5	16.5	5.5	86.2	102.5	81.4	22	29.5	36.9	16	12	12
1.Y13278	SCPSb-15-S04-NC-VD	18	18.6	4.4	6	8	2.6	77.5	147	40.8	47.5	16.5	5.5	86.2	102.5	81.4	22	29.5	36.9	16	12	12

货号 (PN)	型号 (Model)	喷嘴-Ø Nozzle (mm)	真空度 Vacuum [%]	最大抽吸速率 Maximum suction rate (l/min)	耗气量 <sup>(1)</sup> Air consumption (l/min)		噪音等级 <sup>(1)</sup> Noise level [dB(A)]		工作压力 Work pressure (bar)	推荐真空管内径 Recommended vacuum tube inner diameter [mm]		工作温度 Work temperature (°C)
					吸气 Inhale	吹气 Blow	空载状态 No-load state	吸取状态 Absorption state		压缩空气管 Compressed air pipe	真空管 Vacuum tube	
1.Y13276	SCPSb-07-S04-NC-VD	0.7	85	16	22	116	61	58	2...6	4	4	0...50
1.Y13277	SCPSb-10-S04-NC-VD	1.0	85	34	46	116	73	60	2...6	4	4	0...50
1.Y13278	SCPSb-15-S04-NC-VD	1.5	85	64	59	116	76	65	2...6	4	6	0...50

\*所有流量参数均指的是环境大气压(ANR)为101.3kPa, 温度和湿度分别为20°C和65%条件下的参数。

\*All flow parameters refer to the parameters under the conditions of ambient atmospheric pressure (ANR) of 101.3kPa, temperature and humidity of 20°C and 65% respectively

\*压缩空气质量: 达到ISO 8573-1, 3-3-3级, 过滤等级(40 μm)含油或不含油。

\*Compressed air quality: up to ISO 8573-1, level 3-3-3, filter grade (40 μm) with or without oil.

(1)工作压力4bar以下。

(1) Working pressure below 4 bar.

Profile、SUS Tube  
型材、钢管

Stents Module  
支架模组

Quick Changer  
快换

Grip Module  
夹具组件

Air Nipper  
气动剪刀

Vacuum Module  
真空组件

Accessory Components  
附件

# I/O模组 信号盒

## I/O Module Signal Boxes

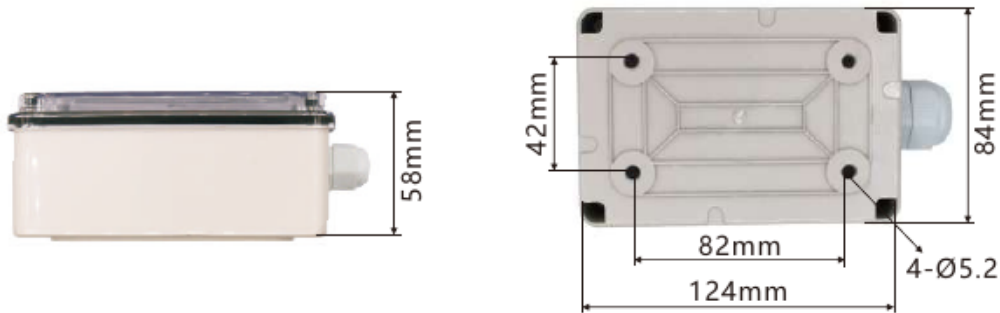

货号(PN)	8.Y00087
型号(Model)	ASC-8A-B

外部接入信号 1-8, 共 8 组, 24V, X1, 0V  
 Outside input signal 1-8, A total of 8 sets, 24V, X1, 0V

电源接入 DC24V  
 Power input DC24V

8 组串联输出类型  
 YPNP:24V 输出 YNPN:0V 输出  
 NO: 常开输出 COM  
 NC: 常闭输出  
 8 sets of tandem output types  
 YPNP:24V output YNPN:0V output  
 NO: normally open output, COM  
 NC: normally closed output

单一信号输出,  
 分别对应 X1-X8  
 Single signal output,  
 Correspond to X1-X8  
 respectively

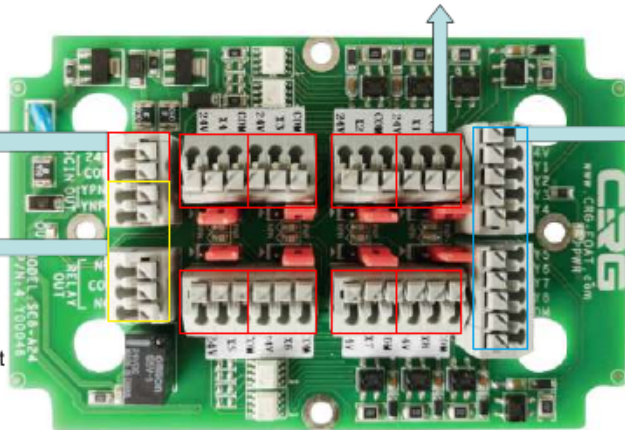

NPN 输入

输入信号类型切换  
 Input signal type change

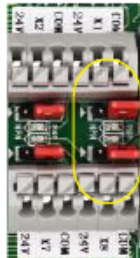

PNP 输入

8 组对应信号指示灯  
 8 sets of corresponding signal indicator light

电源指示灯  
 Power light

输出指示灯  
 Output light

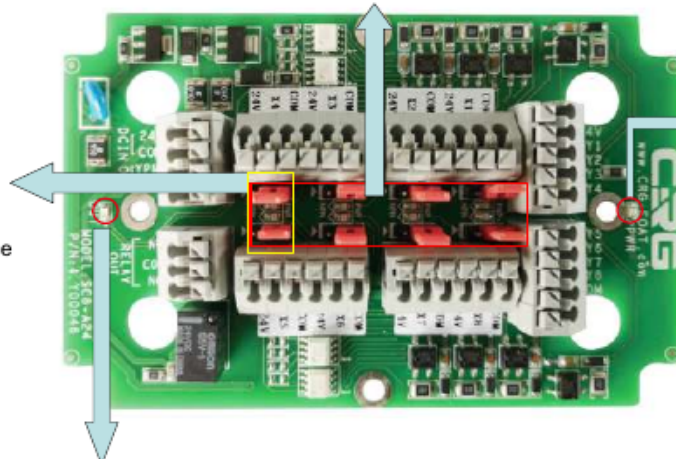

Profile- SUS Tube

Stents Module

Quick Changer

Grip Module

Air Nipper

Vacuum Module

Accessory Components

# I/O模组 信号盒

## I/O Module Signal Boxes

### 操作说明

#### Operation description

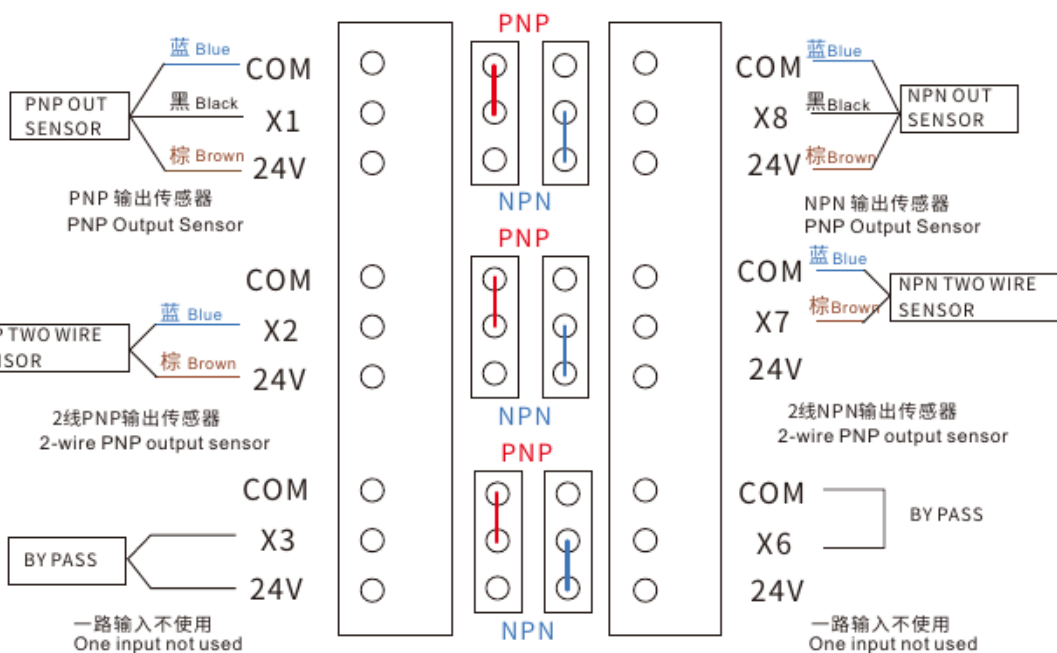

	最小 minimum	推荐 Recommend	最大 Maximum	单位 Unit
电源电压 supply voltage	20	24	28	V
输入端有效电流值 Value of effective current at input	5	7	10	mA
晶体管输出最大负载 Transistor Output Maximum Load			100	mA
继电器输出端负载能力(阻性负载时) Relay Output Load Capability (Resistive Load)			0.5A@125VAC 1A@24VDC	
最大开关频率 Maximum switching frequency		TBD		Hz

1. 解决多个传感器串成一路后电源功率不够的问题, 取消继电器转换, 占地空间的问题。最多可使用8组, 不足8组需要短接。
  2. 输出类型的可变更, 目前为NPN, PNP, NC, NO四种输出形式。
  3. 也可以单独抓取信号, 抓取的信号类型为感应器的实际类型。
  4. 可观察每个感应器的感应状态, 以及输出的状态。
  5. 感应器与输出类型不符时, 可利用跳针将类型转化, 减去更换感应器的工作。
1. To solve the problem that the power supply of multiple sensors is not connected as one line, the problem of space occupation is cancelled. The maximum 8 groups can be used, and less than 8 groups need to be shorted.
  2. Output types can be changed at present for NPN, PNP, NC, NO, and four output forms.
  3. You can also crawl the signal individually, and grab the signal type for the actual type of sensor.
  4. Observe the induction state of each inductor and the status of the output.
  5. Types of sensors and output is not available, skipping type conversion, minus the replacement work of the sensor.

Profile, SUS Tube  
型材、钢管

Stents Module  
支架模组

Quick Changer  
快换

Grip Module  
夹具组件

Air Ripper  
气动剥刀

Vacuum Module  
真空组件

Accessory Components  
附件

# 分线盒

## Junction Box

外壳材质:尼龙,黑色  
 锁紧螺母:黄铜镀镍  
 针托:TPU材质,黑色  
 触点:黄铜镀金  
 防护等级:IP67

负载:10~30VDC,6A 总电流强度,2A分口电流强度,LED 10mA  
 使用环境温度:-30...+80°C  
 单通道PNP NPN

Housing material:Nylon/Black  
 Coupling nut:Brass/Nicket  
 Contact carrier:TPU/Black  
 Pin:Brass/Gold  
 IP degree:IP67

Load:10~30VDC,2 A/port, 6 A total,LED 10mA  
 Temperature range:-30...+80°C  
 Single channel PNP or NPN



### 型号表示方法

#### Model representation methods

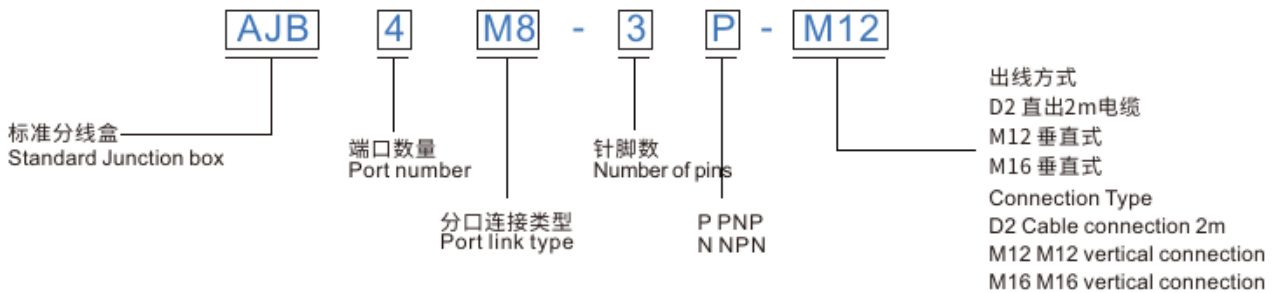

货号(PN)	型号(Model)	类型(Type)	重量(Weight)
4.Y00487	AJB4M8-3P-M12	PNP	110g
4.Y00488	AJB4M8-3N-M12	NPN	110g
4.Y00491	AJB8M8-3P-M16	PNP	120g
4.Y00492	AJB8M8-3N-M16	NPN	120g
4.Y00495	AJB8M8-3P-D2	PNP	300g
4.Y00496	AJB8M8-3N-D2	NPN	300g

#### 1. 单通道 PNP NPN

2. 四路输入同时有效,输出一组信号,实现"与电路"输出功能(选配)

#### 1. Single channel PNP or NPN

2. The four way input is effective at the same time, and outputs a set of signals to realize the output function of "and circuit".

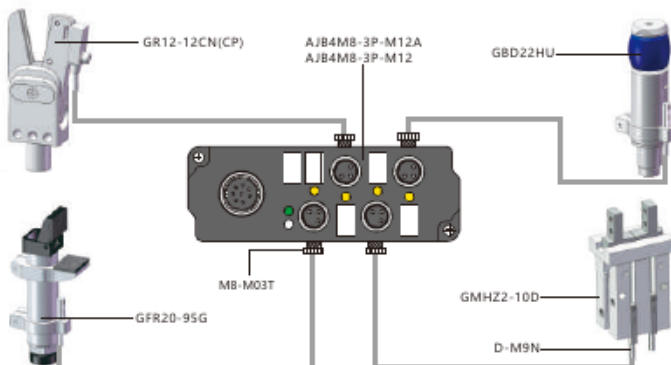

# M8四分口分线盒

## M8 4 Ports Junction Box

外壳材质:尼龙,黑色

锁紧螺母:黄铜镀镍

针托:TPU材质,黑色

触点:黄铜镀金

防护等级:IP67

负载:10~30VDC,6A 总电流强度,2A分口电流强度,LED 10mA

使用环境温度:-30...+80°C

Housing material:Nylon/Black

Coupling nut:Brass/Nicket

Contact carrier:TPU/Black

Pin:Brass/Gold

IP degree:IP67

Load:10~30VDC,2 A/port, 6 A total,LED 10mA

Temperature range:-30...+80°C

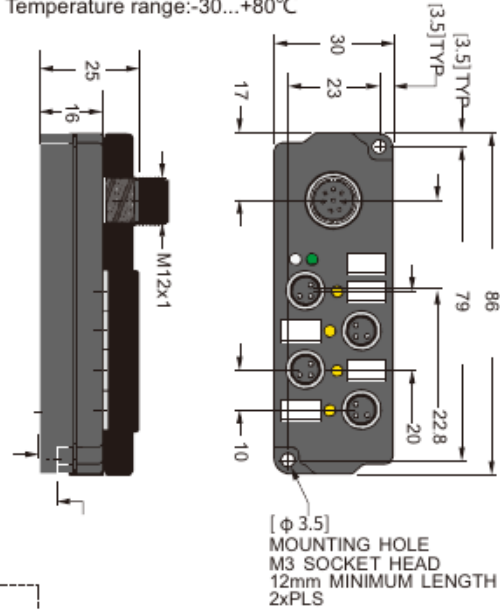

单通道PNP NPN  
每分口1路信号  
带LED 显示灯  
垂直式M12连接器

Single channel PNP or NPN  
1 signal per port  
LED  
M12 vertical connector

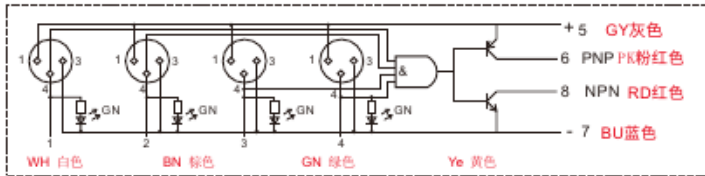

AJB4M8-3P-M12

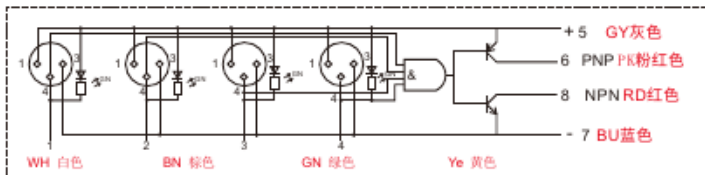

AJB4M8-3N-M12

### 针脚排列图/Pinout

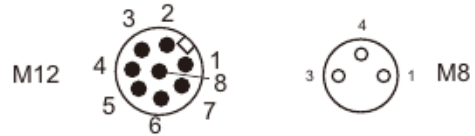

- 1.WH白色
- 2.BN棕色
- 3.GN绿色
- 4.YE黄色
- 5.GY灰色
- 6.PK粉红色
- 7.BU蓝色
- 8.RD红色

### 接头

#### Joint



8针M12现场可接线连接器  
8 pins M12 Field wirable connector



3针M8现场可接线连接器  
3 pins M8 Field wirable connector



3针M8现场可接线连接器  
3 pins M8 Field wirable connector



8针M12预铸电缆  
8 pins M12 pre-moulding Cable

### 孔座/Female



\* 线材长为2米 The wire length is 2 meters

货号(PN)	型号(Model)	类型(Type)	重量(Weight)
4.Y00487	AJB4M8-3P-M12	PNP	110g
4.Y00488	AJB4M8-3N-M12	NPN	110g

# M8八分口分线盒

## M8 8 Ports Junction Box

外壳材质:尼龙,黑色  
 锁紧螺母:黄铜镀镍  
 针托:TPU材质,黑色  
 触点:黄铜镀金  
 防护等级:IP67  
 负载:10~30VDC,6A 总电流强度,2A分口电流强度,LED 10mA  
 使用环境温度:-30...+80°C

Housing material:Nylon/Black  
 Coupling nut:Brass/Nickel  
 Contact carrier:TPU/Black  
 Pin:Brass/Gold  
 IP degree:IP67  
 Load:10~30VDC,2 A/port, 6 A total,LED 10mA  
 Temperature range:-30...+80°C



单通道PNP NPN  
 每分口1路信号  
 带 LED 显示灯  
 垂直式M16连接器

Single channel PNP or NPN  
 1 signal per port  
 LED  
 M16 vertical connector

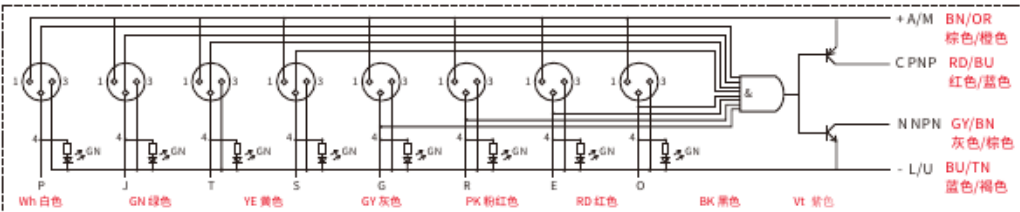
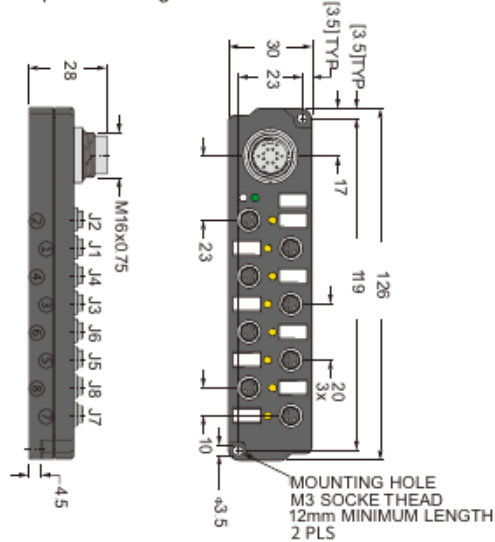

AJB8M8-3P-M16

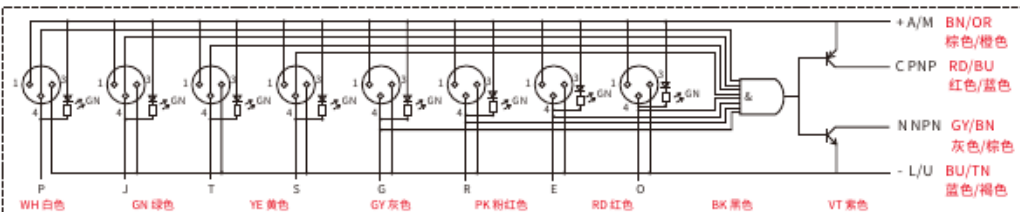

AJB8M8-3N-M16

### 针脚排列图/Pinout

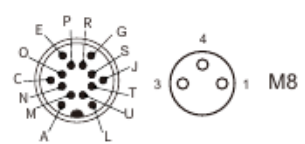

### 接头

#### Joint



14针M16预铸电缆  
 14 pins M16 pre-moulding Cable

货号(PN)	1Y07463
型号(Model)	DNLK14-14-2M/P00



3针M8现场可接线连接器  
 3 pins M8 Field wirable connector

货号(PN)	1Y06722
型号(Model)	M8-M03T



3针M8现场可接线连接器  
 3 pins M8 Field wirable connector

货号(PN)	1Y13391
型号(Model)	M8-M03L

### 孔座/Female



- A BN 棕色
- C.RD/BU 红色/蓝色
- E.BK 黑色
- G.PK 粉红色
- J. GN 绿色
- L. BU 蓝色
- M.OR 褐色
- N.GY/BN 灰色/棕色
- O.VT 紫色
- P.WH 白色
- R.RD 红色
- S.GY 灰色
- T.YE 黄色
- U.TN 褐色

\* 线材长为2米 The wire length is 2 meters

货号(PN)	型号(Model)	类型(Type)	重量(Weight)
4.Y00491	AJB8M8-3P-M16	PNP	120g
4.Y00492	AJB8M8-3N-M16	NPN	120g

Profile- SUS Tube  
 型材、钢管

Stents Module  
 支架模组

Quick Changer  
 快换

Grip Module  
 夹具组件

Air Nipper  
 气动剪刀

Vacuum Module  
 真空组件

Accessory Components  
 附件

# M8八分口分线盒

## M8 8 Ports Junction Box

外壳材质:尼龙,黑色  
 锁紧螺母:黄铜镀镍  
 针托:TPU材质,黑色  
 触点:黄铜镀金  
 防护等级:IP67

负载:10~30VDC,6A 总电流强度,2A分口电流强度,LED 10mA  
 使用环境温度:-30...+80°C

Housing material:Nylon/Black  
 Coupling nut:Brass/Nicket  
 Contact carrier:TPU/Black  
 Pin:Brass/Gold  
 IP degree:IP67

Load:10~30VDC,2 A/port, 6 A total,LED 10mA  
 Temperature range:-30...+80°C

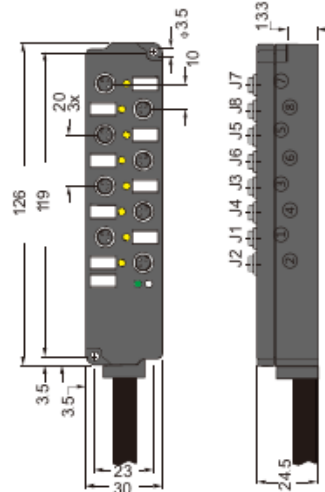

单通道PNP NPN  
 每分口1路信号  
 带 LED 显示灯  
 2m黑色10芯 PVC 线

Single channel PNP or NPN  
 1 signal per port  
 LED  
 Black PVC wire with 10 cores in 2m

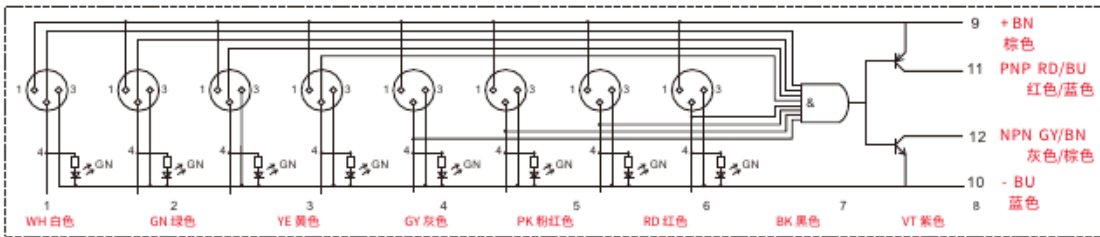

AJB8M8-3P-D2

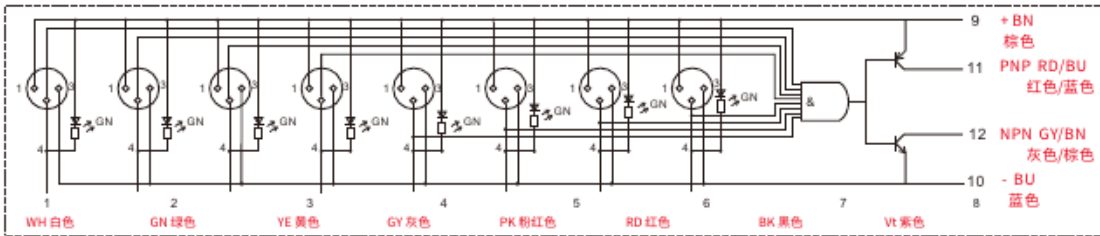

AJB8M8-3N-D2

### 接头

Joint



3针M8现场可接线连接器  
 3 pins M8 Field wirable connector

3针M8现场可接线连接器  
 3 pins M8 Field wirable connector

货号(PN)	1.Y06722
型号(Model)	M8-M03T

货号(PN)	1.Y13391
型号(Model)	M8-M03L

### 信号线截面示意图

Signal Wire Cross-sectional Sketch Map



货号(PN)	型号(Model)	类型(Type)	重量(Weight)
4.Y00495	AJB8M8-3P-D2	PNP	300g
4.Y00496	AJB8M8-3N-D2	NPN	300g

\* 标准长度为2米,可订制长度

\* The standard length is 2 meters, which can be customized.

Profile、SUS Tube  
型材、钢管

Stents Module  
支架模组

Quick Changer  
快换

Grip Module  
夹具组件

Air Nipper  
气动剪刀

Vacuum Module  
真空组件

Accessory Components  
附件

## 微型减压阀 ARJ210系列

### Miniature Regulator ARJ210 Series

本体材质为铝, 轻量(60g)  
IN侧配管连接用1/8(外螺纹)  
M5(内螺纹)2种类型.

The body is made of aluminum, lightweight (60g)  
IN side pipe connections are made with 1/8 (external thread)  
M5 (internal thread) 2 types

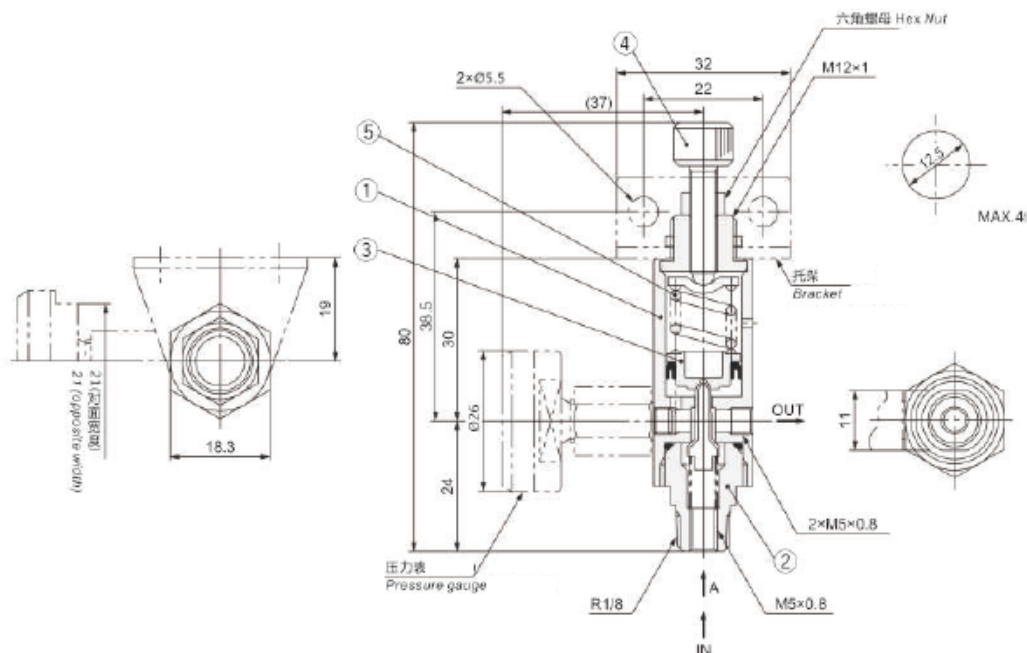

货号(PN)		1.Y05877
型号(Model)		ARJ210-M5BG
接管口径 Pipe Siz	IN侧	1/8 (F-外螺纹)及M5×0.8(M-内螺纹)
	OUT侧	M5×0.8(F-内螺纹2处)
使用流体 Fluid		空气 Air
保证耐压力 Proof pressure		1.2MPa
最高使用压力 Maximum Operating pressure		0.8MPa
设定压力范围 Set pressure range		0.2~0.7MPa
		0.2MPa: 0.05~0.2MPa
压力表连接口径 Pressure gauge connecting caliber		M5×0.8(M-内螺纹)
环境温度及使用流体温度 Environment and fluid temperature		-5~60°C
重量(kg) Weight		0.06

型材、钢管  
Profile, SUS Tube

支架模组  
Stents Module

快换  
Quick Changer

夹具组件  
Grip Module

气动剪刀  
Air Nipper

真空组件  
Vacuum Module

附件  
Accessory Components

## 钢棒切割器

### Tube Cutter



用于切割铜管、铝管、不锈钢管  
选用高品质合金工具钢刀片，便于更换内有可收缩去毛刺刀片，  
使用简单、携带方便，重量(248g)  
Special tool for cutting copper tube  
Ease to use  
Improve work efficiency  
Durable,high-quality,weight (248g)

货号(PN)	1.Y02592
--------	----------

## 信号针取针工具

### Signal Needle Removal Tool

信号针取针工具是用信号模块维修和制造的专用工具。  
根据信号模块选择合适的工具，使用简单、携带方便。  
操作时注意力度控制，避免用力过猛损坏信号针。

Signal pin removal tool is a special tool for repairing and manufacturing with signal modules.  
Choose the right tool according to the signal module, simple to use and easy to carry.  
Pay attention to the strength control during operation to avoid damaging the signal pin with too much force.



货号(PN)	7.Y02671
型号(Model)	2.8-60T

※重量Weight:51g  
※适用模块 Applicable Modules:  
QCSM-12R、QCSM-26R、QCSM-19R、QCSM-19R1、  
QCSM-32R、QCSM-RJ45-06R



货号(PN)	7.Y02672
型号(Model)	5.5-60T

※重量Weight:54g  
※适用模块 Applicable Modules:  
QCSM-08R、QCSM-08R1、QCHFM-E14-C1R

Profile、SUS Tube  
型材、钢管

Stents Module  
支架模组

Quick Changer  
快换

Grip Module  
夹具组件

Air Nipper  
气动剪刀

Vacuum Module  
真空组件

Accessory Components  
附件

# 金属接头

## Connector

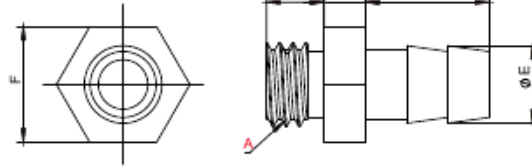

货号(PN)	型号(Model)	A	B	C	D	E	F	重量 Weight
1.Y03145	APB-M3-Ø4	M3	4	2	5.5	3.5	4.5	0.6g
1.Y05008	APB-M5-Ø4	M5	5	2	6.5	3.5	7	1.4g
1.Y01986	APB-M5-Ø6	M5	4.5	2.5	7	4.8	7	1.7g

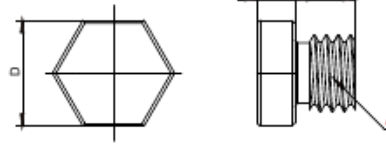

货号(PN)	型号(Model)	A	B	C	D	重量 Weight
1.Y06794	APF-M3	M3	2	3	4.9	0.5g
1.Y02510	APF-M5	M5	2.5	4.5	7	1.4g

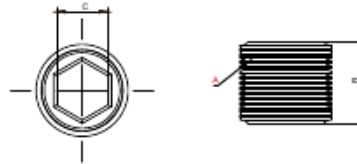

货号(PN)	型号(Model)	A	B	C	重量 Weight
1.Y00462	APF-G18	G1/8	8	5	3.0g
1.Y00463	APF-G14	1/4	9	6	6.2g

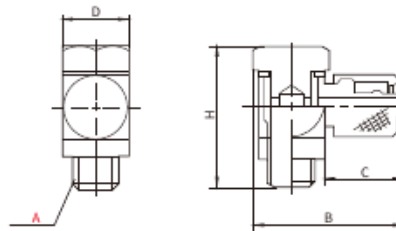

货号(PN)	型号(Model)	A	B	C	D	H	重量 Weight
1.Y13282	APBL-M3-Ø4	M3	9.5	4.5	5	9.5	0.8g
1.Y13283	APBL-M5-Ø4	M5	15.5	8.5	7	15	4.5g
1.Y13284	APBL-M5-Ø6	M5	17.5	9.5	8	16	6.6g
1.Y13285	APBL-G18-Ø6	G1/8	20	9	10	21.5	13g

Profile- SUS Tube  
型材、钢管

Stents Module  
支架模组

Quick Changer  
快换

Grip Module  
夹具组件

Air Nipper  
气动剪刀

Vacuum Module  
真空组件

Accessory Components  
附件

# 接头

## Connector

KQ2系列 KQ2 series

直通接头:KQ2H(密封垫密封)

Straight connector :KQ2H(gasket seal)

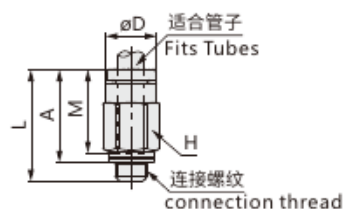

适合管子 外径 mm Fits Tubes Outside diameter	货号(PN)	型号(Model)	连接螺纹 M Connection thread	H (六角对边) (hexagonal)	øD	L	A	M	有效面积mm Effective cross-sectional area		最小孔径 Minimum Hole Diameter	重量 Weight
									尼龙 Nylon	聚酰胺 Organizational		
ø2	1.Y13101	KQ2H02-M3G	M3×0.5	7	5.5	15.6	13	11.9	—	0.9	1.2	1.5g
	1.Y13102	KQ2H02-M5A	M5×0.8	7	5.5	13.8	10.8	11.9	—	0.9	1.4	2g
ø3.2	1.Y13103	KQ2H23-M3G	M3×0.5	7	6.7	17	14.4	13.3	0.9	0.9	1.2	2.4g
	1.Y13104	KQ2H23-M5A	M5×0.8	7	6.7	17.3	14.3	13.3	3	2.5	2.5	2.7g
ø4	1.Y13105	KQ2H04-M3G	M3×0.5	8	7.7	17.1	14.5	13.3	0.9	0.9	1.2	2.9g
	1.Y04451	KQ2H04-M5A	M5×0.8	8	7.7	17.7	14.7	13.3	4	4	2.5	3.3g
	1.Y13106	KQ2H04-M6A	M6×1.0	8	7.7	18.7	14.7	13.3	4	4	3	3.6g
ø6	1.Y04452	KQ2H06-M5A	M5×0.8	10	9.7	17.7	14.7	13.3	4	4	2.5	4.1g
	1.Y13107	KQ2H06-M6A	M6×1.0	10	9.7	18.8	14.8	13.3	4	4	3	4.4g

KQ2系列 KQ2 series

直通接头:KQ2H(密封剂)

Straight connector :KQ2H(sealant)

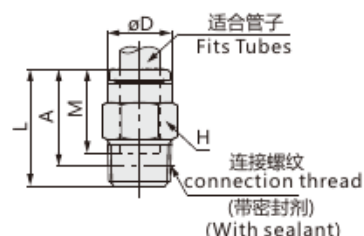

适合管子 外径 mm Fits Tubes Outside diameter	货号(PN)	型号(Model)	连接螺纹 R Connection thread	H (六角对边) (hexagonal)	øD	L	A※	M	有效截面积mm Effective cross-sectional area		最小孔径 Minimum Hole Diameter	重量 Weight
									尼龙 Nylon	聚酰胺 Organizational		
ø3.2	1.Y13108	KQ2H23-01AS	1/8	10	6.7	14	10.9	13.3	3.4	2.9	2.5	6g
	1.Y13109	KQ2H23-02AS	1/4	14	6.7	16.7	12	13.3	3.4	2.9	2.5	15.3g
ø4	1.Y03599	KQ2H04-01AS	1/8	10	7.7	14.3	11.2	13.3	5.6	4	3	5.6g
	1.Y05147	KQ2H04-02AS	1/4	14	7.7	16.7	12	13.3	5.6	4	3	14.6g
ø6	1.Y13110	KQ2H06-01AS	1/8	10	9.7	18.4	15.3	13.3	13.1	10.4	4.5	5.8g
	1.Y07090	KQ2H06-02AS	1/4	14	9.7	16.7	12	13.3	13.1	10.4	4.5	12.5g
	1.Y05164	KQ2H06-03AS	3/8	17	9.7	18.1	13	13.3	13.1	10.4	4.5	24.5g
ø8	1.Y07162	KQ2H08-01AS	1/8	14	12.2	22.5	19.4	14.2	26.1	18	6	11.9g
	1.Y05101	KQ2H08-02AS	1/4	14	12.2	22	17.3	14.2	26.1	18	6	13.9g
	1.Y02228	KQ2H08-03AS	3/8	17	12.2	18.1	13	14.2	26.1	18	6	21g
ø10	1.Y13111	KQ2H10-01AS	1/8	17	14.6	23.8	20.7	15.6	26.1	26.1	6	16.9g
	1.Y07142	KQ2H10-02AS	1/4	17	14.6	27.3	22.6	15.6	41.5	29.5	7.5	22.1g
	1.Y07632	KQ2H10-03AS	3/8	17	14.6	23.5	18.4	15.6	41.5	29.5	7.5	22.5g
	1.Y13112	KQ2H10-04AS	1/2	22	14.6	22.3	15.9	15.6	41.5	29.5	7.5	44.7g
ø12	1.Y13113	KQ2H12-02AS	1/4	19	17	28.7	24	17	58.3	46.1	9	24.3g
	1.Y13114	KQ2H12-03AS	3/8	19	17	25.9	20.8	17	58.3	46.1	9	25.2g
	1.Y13115	KQ2H12-04AS	1/2	22	17	22.3	15.9	17	58.3	46.1	9	37.7g
ø16	1.Y13116	KQ2H16-02AS	1/4	24	21.8	32.5	27.8	20.6	58.3	46.1	9	37.4g
	1.Y13117	KQ2H16-03AS	3/8	24	21.8	33.1	28	20.6	81	67	11	42.4g
	1.Y13118	KQ2H16-04AS	1/2	24	21.8	32.1	25.7	20.6	113	67	13	44.6g

※ R螺纹拧入后的参考尺寸

※ R reference dimension of R thread after screwing in

# 接头

## Connector

KQ2系列 KQ2 series

直通接管: KQ2H

Straight joint: KQ2H

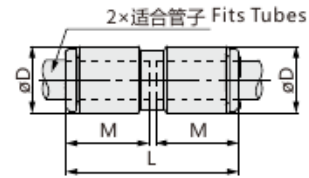

适合管子 外径 mm Fits Tubes Outside diameter	货号(PN)	型号(Model)	øD*	L	M	有效截面积mm Effective cross-sectional area		最小孔径 Minimum Hole Diameter	重量 Weight
						尼龙 Nylon	聚氨酯 Organosilicon		
ø2	1.Y13119	KQ2H02-00A	5.8	24.8	11.9	-	0.9	1.4	0.8g
ø3.2	1.Y13120	KQ2H23-00A	7.1	27.6	13.3	3.4	2.9	2.5	1.4g
ø4	1.Y13121	KQ2H04-00A	8.2	27.6	13.3	5.6	4	3	1.6g
ø6	1.Y13122	KQ2H06-00A	10.4	27.6	13.3	13.1	10.4	4.5	2.1g
ø8	1.Y13123	KQ2H08-00A	13.2	29.4	14.2	26.1	18	6	3.7g
ø10	1.Y13124	KQ2H10-00A	15.9	32.2	15.6	41.5	29.5	7.5	5.5g
ø12	1.Y13125	KQ2H12-00A	18.5	35	17	58.3	46.1	9	8.2g
ø16	1.Y13126	KQ2H16-00A	23.8	42.2	20.6	113	67	13	15.2g

\* øD 是最大直径。

\* øD are maximum diameters.

KQ2系列 KQ2 series

异型直通接管: KQ2H

Special type through connection: KQ2H

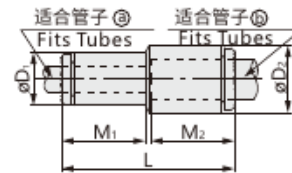

适合管子 外径 mm Fits Tubes Outside diameter		货号(PN)	型号(Model)	øD <sub>1</sub> *	øD <sub>2</sub> *	L	M <sub>1</sub>	M <sub>2</sub>	有效截面积mm Effective cross-sectional area		最小孔径 Minimum Hole Diameter	重量 Weight
①	②								尼龙 Nylon	聚氨酯 Organosilicon		
ø2	ø3.2	1.Y13127	KQ2H02-23A	5.8	7.1	26.2	11.9	13.3	-	0.9	1.4	1.1g
ø2	ø4	1.Y13128	KQ2H02-04A	5.8	8.2	26.2	11.9	13.3	-	0.9	1.4	1.2g
ø3.2	ø4	1.Y13129	KQ2H23-04A	7.1	8.2	27.6	13.3	13.3	3.4	2.9	2.5	1.5g
ø3.2	ø6	1.Y13130	KQ2H23-06A	7.1	10.4	27.6	13.3	13.3	3.4	2.9	2.5	1.8g
ø4	ø6	1.Y13131	KQ2H04-06A	8.2	10.4	27.6	13.3	13.3	5.6	5.6	3	2g
ø6	ø8	1.Y13132	KQ2H06-08A	10.4	13.2	28.5	13.3	14.2	13.1	10.4	4.5	2.9g
ø8	ø10	1.Y13133	KQ2H08-10A	13.2	15.9	30.8	14.2	15.6	26.1	18	6	4.9g
ø10	ø12	1.Y13134	KQ2H10-12A	15.9	18.5	33.6	15.6	17	41.5	29.5	7.5	7.2g
ø12	ø16	1.Y13135	KQ2H12-16A	18.5	23.8	38.6	17	20.6	58.3	46.1	9	12.4g

\* øD<sub>1</sub>、øD<sub>2</sub> 是最大直径。

\* øD<sub>1</sub>、øD<sub>2</sub> are maximum diameters.

Profile - SUS Tube  
型材、钢管

Stents Module  
支架模组

Quick Changer  
快换

Grip Module  
夹具组件

Air Nipper  
气动剪刀

Vacuum Module  
真空组件

Accessory Components  
附件

# 接头

## Connector

KQ2系列 KQ2 series

弯头: KQ2L(密封垫密封)

Elbow: KQ2L(gasket seal)

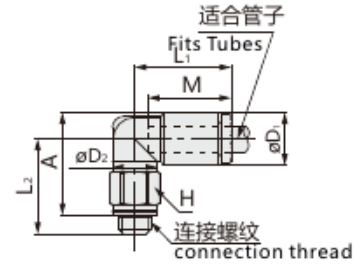

适合管子 外径 mm Fits Tubes Outside diameter	货号(PN)	型号(Model)	连接螺纹 M Connection thread	H (六角对边) (hexagonal)	$\phi D_1^*$	$\phi D_2$	L	L <sub>1</sub>	A	M	有效截面积mm <sup>2</sup> Effective cross-sectional area 尼龙 Nylon 聚氨酯 Urethane	最小 孔径 Minimum Hole Diameter	重量 Weight	
ø2	1.Y13136	KQ2L02-M3G	M3×0.5	5.5	5.8	5.5	12.6	12.5	12.8	11.9	-	0.8	1.2	1.6g
	1.Y13137	KQ2L02-M5A	M5×0.8	7	5.8	5.5	12.6	13	12.9	11.9	-	0.8	1.4	2.7g
ø3.2	1.Y13138	KQ2L23-M3G	M3×0.5	7	7.1	7	15.3	13.8	14.8	13.3	13.3	0.8	1.2	2.7g
	1.Y13139	KQ2L23-M5A	M5×0.8	7	7.1	7	15.3	14.3	14.9	13.3	13.3	2.2	2.5	3.1g
ø4	1.Y13140	KQ2L04-M3G	M3×0.5	7	8.2	7	15.4	14.3	15.8	13.3	13.3	0.8	1.2	2.7g
	1.Y02599	KQ2L04-M5A	M5×0.8	7	8.2	7	15.4	14.8	15.9	13.3	13.3	3.5	2.5	3.1g
	1.Y13141	KQ2L04-M6A	M6×1.0	8	8.2	7	15.4	15.8	15.9	13.3	13.3	3.5	2.5	4.2g
ø6	1.Y02345	KQ2L06-M5A	M5×0.8	7	10.4	7	14.5	16.5	18.7	13.3	13.3	3.5	2.5	3.2g
	1.Y13142	KQ2L06-M6A	M6×1.0	8	10.4	7	14.5	17.5	18.7	13.3	13.3	3.5	2.5	4.3g

\*  $\phi D_2$  是最大直径。

\*  $\phi D_2$  are maximum diameters.

KQ2系列 KQ2 series

弯头: KQ2L(密封剂)

Elbow: KQ2L(sealant)

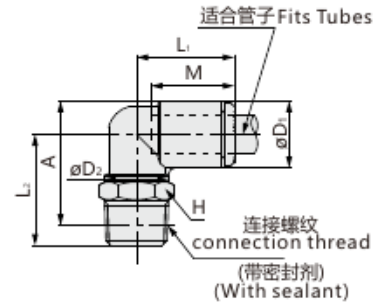

适合管子 外径 mm Fits Tubes Outside diameter	货号(PN)	型号(Model)	连接螺纹 M Connection thread	H (六角对边) (hexagonal)	$\phi D_1^*$	$\phi D_2$	L	L <sub>1</sub>	A <sup>*</sup>	M	有效截面积mm <sup>2</sup> Effective cross-sectional area 尼龙 Nylon 聚氨酯 Urethane	最小 孔径 Minimum Hole Diameter	重量 Weight	
ø3.2	1.Y13143	KQ2L23-01AS	1/8	10	7.1	10	14.5	16.7	17.2	13.3	3	2.5	2.5	4.6g
	1.Y13144	KQ2L23-02AS	1/4	14	7.1	10	14.5	21.2	20.1	13.3	3	2.5	2.5	14.1g
ø4	1.Y05151	KQ2L04-01AS	1/8	10	8.2	10	14.8	16.2	17.2	13.3	4.2	4.2	3	4.8g
	1.Y05751	KQ2L04-02AS	1/4	14	8.2	10	14.8	21.7	21.1	13.3	4.2	4.2	3	14.3g
ø6	1.Y02343	KQ2L06-01AS	1/8	10	10.4	10	15.5	17.3	19.4	13.3	11.4	9	4.5	5.2g
	1.Y11935	KQ2L06-02AS	1/4	14	10.4	10	15.5	22.8	23.3	13.3	11.4	9	4.5	14.7g
	1.Y10180	KQ2L06-03AS	3/8	17	10.4	10	15.5	24.1	24.2	13.3	11.4	9	4.5	26.5g
ø8	1.Y07560	KQ2L08-01AS	1/8	10	13.2	10	16.4	18.7	22.2	14.2	11.4	11.4	4.5	6.1g
	1.Y04922	KQ2L08-02AS	1/4	14	13.2	12	17.2	25.4	27.3	14.2	21.6	14.9	6	17.7g
	1.Y05070	KQ2L08-03AS	3/8	17	13.2	12	17.2	25.5	27.0	14.2	21.6	14.9	6	24.7g
ø10	1.Y13145	KQ2L10-01AS	1/8	12	15.9	12	18.6	23.6	28.4	15.6	21.6	14.9	6	11.1g
	1.Y06994	KQ2L10-02AS	1/4	17	15.9	17	19.3	28.7	31.9	15.6	35.2	25	7.5	21.7g
	1.Y08074	KQ2L10-03AS	3/8	17	15.9	17	19.3	29.6	32.4	15.6	35.2	25	7.5	22.2g
ø12	1.Y13146	KQ2L10-04AS	1/2	22	15.9	17	19.3	33.6	35.1	15.6	35.2	25	7.5	44.6g
	1.Y13147	KQ2L12-02AS	1/4	17	18.5	17	21.5	30.0	34.5	17	50.2	39.7	9	23.5g
	1.Y13148	KQ2L12-03AS	3/8	17	18.5	17	21.5	30.9	35.0	17	50.2	39.7	9	24.1g
ø16	1.Y13149	KQ2L12-04AS	1/2	22	18.5	17	21.5	34.9	37.7	17	50.2	39.7	9	46.5g
	1.Y13150	KQ2L16-02AS	1/4	17	23.8	17	25.1	32.6	39.8	20.6	50.2	50.2	9	27.8g
	1.Y13151	KQ2L16-03AS	3/8	22	23.8	21	27.1	35.4	42.2	20.6	71	58.9	11	40.8g
	1.Y13152	KQ2L16-04AS	1/2	22	23.8	21	27.1	34.1	39.6	20.6	100	58.9	13	44.5g

※ R螺纹拧入后的参考尺寸

※ R reference dimension of R thread after screwing in

\*  $\phi D_2$  是最大直径。

\*  $\phi D_2$  are maximum diameters.

# 接头

## Connector

KQ2系列 KQ2 series

万向弯头:KQ2V(密封垫密封)

Universal elbow :KQ2V(gasket seal)

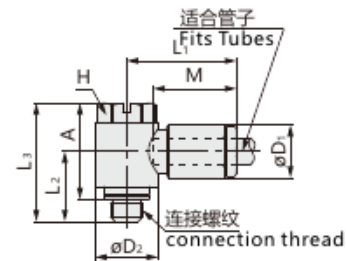

适合管子 外径 mm Fits Tubes Outside diameter	货号(PN)	型号(Model)	连接螺纹 M Connection thread	H (六角对边) (hexagonal)	øD <sub>1</sub> *	øD <sub>2</sub>	L <sub>1</sub>	L <sub>2</sub>	L <sub>3</sub>	A	M	有效截面积mm <sup>2</sup> Effective cross-sectional area		最小 孔径 Minimum Hole Diameter	重量 Weight
												尼龙 Nylon	聚氨酯 Polyurethane		
ø4	1.Y13153	KQ2V04-M5A	M5×0.8	8	8.2	9.8	17.5	10.9	18.4	14.9	13.3	2.9	2.9	2.5	5.4g
ø6	1.Y13154	KQ2V06-M5A	M5×0.8	8	10.4	9.8	18.3	10.9	18.4	14.9	13.3	3.8	3.8	2.5	5.7g

\* øD<sub>1</sub> 是最大直径。

\* øD<sub>1</sub> are maximum diameters.

KQ2系列 KQ2 series

万向弯头:KQ2V(密封剂)

Universal elbow:KQ2V(sealant)

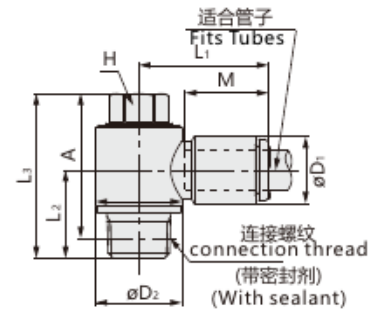

适合管子 外径 mm Fits Tubes Outside diameter	货号(PN)	型号(Model)	连接螺纹 M Connection thread	H (六角对边) (hexagonal)	øD <sub>1</sub> *	øD <sub>2</sub>	L <sub>1</sub>	L <sub>2</sub>	L <sub>3</sub>	A <sup>※</sup>	M	有效截面积mm <sup>2</sup> Effective cross-sectional area		最小 孔径 Minimum Hole Diameter	重量 Weight
												尼龙 Nylon	聚氨酯 Polyurethane		
ø4	1.Y13155	KQ2V04-01AS	1/8	8	8.2	13.4	19.3	13.7	25.6	22.5	13.3	2.9	2.9	3	13.2g
ø6	1.Y13156	KQ2V06-01AS	1/8	8	10.4	13.4	20.5	13.7	25.6	22.5	13.3	7.5	5.9	4.5	13.5g
	1.Y13158	KQ2V06-02AS	1/4	10	10.4	15.3	19.9	17.9	30.5	25.8	13.3	7.5	5.9	4.5	24.9g
ø8	1.Y13159	KQ2V08-01AS	1/8	12	13.2	17.6	23.5	15.1	27.6	24.5	14.2	16	11.2	6	22.6g
	1.Y13157	KQ2V08-02AS	1/4	12	13.2	17.6	23.5	18.5	31	26.3	14.2	16	11.2	6	29.1g
ø10	1.Y13160	KQ2V08-03AS	3/8	14	13.2	20.6	23.1	19.5	35.3	30.2	14.2	16	11.2	6	44.4g
	1.Y13161	KQ2V10-02AS	1/4	14	15.9	20.6	25.9	19.9	34.9	30.2	15.6	27	20.3	7.5	38.1g
ø12	1.Y13162	KQ2V10-03AS	3/8	14	15.9	20.6	25.9	20.3	35.3	30.2	15.6	27	20.3	7.5	45.7g
	1.Y13163	KQ2V12-03AS	3/8	17	18.5	25.2	28.5	21.4	37.6	32.5	17	39	30.8	9	59.6g
ø16	1.Y13164	KQ2V12-04AS	1/2	17	18.5	25.2	28.5	24.6	40.8	34.4	17	39	30.8	9	78.2g
	1.Y13165	KQ2V16-03AS	3/8	21	23.8	32.3	34.2	25.1	45.4	40.3	20.6	55	46	11	99.5g
ø16	1.Y13166	KQ2V16-04AS	1/2	21	23.8	32.3	34.2	28.3	48.6	42.2	20.6	78	46	13	107.9g

※ R螺纹拧入后的参考尺寸

※ R reference dimension of R thread after screwing in

\* øD<sub>1</sub> 是最大直径。

\* øD<sub>1</sub> are maximum diameters.

# 接头

## Connector

KQ2系列 KQ2 series

双管T形接头:KQ2T(密封垫密封)

Double tube T-joint:KQ2T(gasket seal)

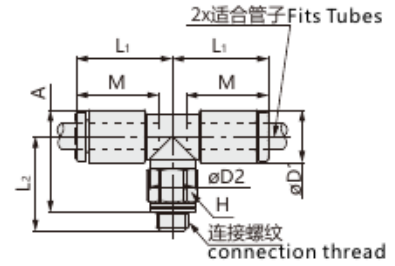

适合管子 外径 mm Fits Tubes Outside diameter	货号(PN)	型号(Model)	连接螺纹 M Connection thread	H (六角对边) (hexagonal)	øD <sub>1</sub> *	øD <sub>2</sub>	L <sub>1</sub>	L <sub>2</sub>	A	M	有效截面积mm <sup>2</sup> Effective cross-sectional area		最小 孔径 Minimum Hole Diameter	重量 Weight
											尼龙Nylon	聚酰胺 Organosilicon		
ø2	1.Y13167	KQ2T02-M3G	M3×0.5	5.5	5.8	5.5	12.6	12.5	12.8	11.9	-	0.9	1.2	1.9g
	1.Y13168	KQ2T02-M5A	M5×0.8	7	5.8	5.5	12.6	13	12.9	11.9	-	0.9	1.4	3g
ø3.2	1.Y13169	KQ2T23-M3G	M3×0.5	7	7.1	7	15.3	13.8	14.7	13.3	0.9	0.9	1.2	3.1g
	1.Y13170	KQ2T23-M5A	M5×0.8	7	7.1	7	15.3	14.3	14.8	13.3	3.2	2.7	2.5	3.5g
ø4	1.Y13171	KQ2T04-M3G	M3×0.5	7	8.2	7	15.4	14.3	15.8	13.3	0.9	0.9	1.2	3.4g
	1.Y01536	KQ2T04-M5A	M5×0.8	7	8.2	7	15.4	14.8	15.9	13.3	4.5	4.5	2.5	3.9g
	1.Y13172	KQ2T04-M6A	M6×1.0	8	8.2	7	15.4	15.8	15.9	13.3	4.5	4.5	2.5	4.9g
ø6	1.Y03052	KQ2T06-M5A	M5×0.8	7	10.4	7	14.5	16.5	18.7	13.3	4.5	4.5	2.5	4.4g
	1.Y13173	KQ2T06-M6A	M6×1.0	8	10.4	7	14.5	17.5	18.7	13.3	4.5	4.5	2.5	5.4g

\* øD<sub>1</sub> 是最大直径。

\* øD<sub>1</sub> are maximum diameters.

KQ2系列 KQ2 series

双管T形接头:KQ2T(密封剂)

Double tube T-joint:KQ2T(sealant)

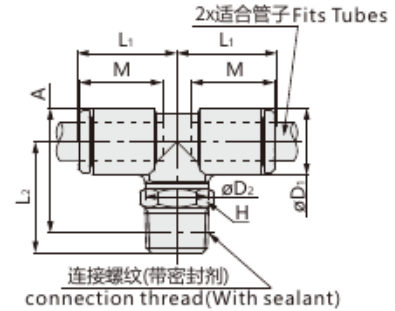

适合管子 外径 mm Fits Tubes Outside diameter	货号(PN)	型号(Model)	连接螺纹 M Connection thread	H (六角对边) (hexagonal)	øD <sub>1</sub> *	øD <sub>2</sub>	L <sub>1</sub>	L <sub>2</sub>	A <sup>※</sup>	M	有效截面积mm <sup>2</sup> Effective cross-sectional area		最小 孔径 Minimum Hole Diameter	重量 Weight
											尼龙Nylon	聚酰胺 Organosilicon		
ø3.2	1.Y13174	KQ2T23-01AS	1/8	10	7.1	10	14.5	16.6	17.1	13.3	3.4	2.9	2.5	5.2g
	1.Y13175	KQ2T23-02AS	1/4	14	7.1	10	14.5	21.1	20	13.3	3.4	2.9	2.5	14.7g
ø4	1.Y13176	KQ2T04-01AS	1/8	10	8.2	10	14.8	16.2	17.2	13.3	6	4.1	3	5.5g
	1.Y13177	KQ2T04-02AS	1/4	14	8.2	10	14.8	21.7	21.1	13.3	6	4.1	3	15g
ø6	1.Y05154	KQ2T06-01AS	1/8	10	10.4	10	15.5	17.3	19.4	13.3	13.9	11	4.5	6.1g
	1.Y13178	KQ2T06-02AS	1/4	14	10.4	10	15.5	22.8	23.3	13.3	13.9	11	4.5	15.6g
	1.Y13179	KQ2T06-03AS	3/8	17	10.4	10	15.5	24.1	24.2	13.3	13.9	11	4.5	27.4g
ø8	1.Y13180	KQ2T08-01AS	1/8	10	13.2	10	16.4	18.7	22.2	14.2	14	14	4.5	7.9g
	1.Y13181	KQ2T08-02AS	1/4	14	13.2	12	17.2	25.4	27.3	14.2	26.3	18.2	6	19.4g
	1.Y13182	KQ2T08-03AS	3/8	17	13.2	12	17.2	25.5	27	14.2	26.3	18.2	6	26.5g
ø10	1.Y13183	KQ2T10-01AS	1/8	12	15.9	12	18.6	23.5	28.4	15.6	21.6	14.9	6	13.9g
	1.Y13184	KQ2T10-02AS	1/4	17	15.9	17	19.3	28.6	31.9	15.6	35.2	25	7.5	24.3g
	1.Y13185	KQ2T10-03AS	3/8	17	15.9	17	19.3	29.5	32.4	15.6	35.2	25	7.5	24.8g
	1.Y13186	KQ2T10-04AS	1/2	22	15.9	17	19.3	33.5	35.1	15.6	35.2	25	7.5	47.3g
ø12	1.Y13187	KQ2T12-02AS	1/4	17	18.5	17	21.5	29.9	34.5	17	57.2	45.2	9	27.3g
	1.Y13188	KQ2T12-03AS	3/8	17	18.5	17	21.5	30.8	35	17	57.2	45.2	9	28g
	1.Y13189	KQ2T12-04AS	1/2	22	18.5	17	21.5	34.8	37.7	17	57.2	45.2	9	50.4g
ø16	1.Y13190	KQ2T16-02AS	1/4	17	23.8	17	25.1	32.6	39.8	20.6	57.2	57.2	9	35.5g
	1.Y13191	KQ2T16-03AS	3/8	22	23.8	21	27.1	35.4	42.2	20.6	71	58.9	11	47.7g
	1.Y13192	KQ2T16-04AS	1/2	22	23.8	21	27.1	34.1	39.6	20.6	100	58.9	13	51.4g

※ R螺纹拧入后的参考尺寸

※ R reference dimension of R thread after screwing in

\* øD<sub>1</sub> 是最大直径。

\* øD<sub>1</sub> are maximum diameters.

Profile、SUS Tube  
型材、钢管

Stents Module  
支架模组

Quick Changer  
快换

Grip Module  
夹具组件

Air Nipper  
气动剪刀

Vacuum Module  
真空组件

Accessory Components  
附件

# 接头

## Connector

KQ2系列 KQ2 series

T形接管:KQ2T

T-shaped connection :KQ2T

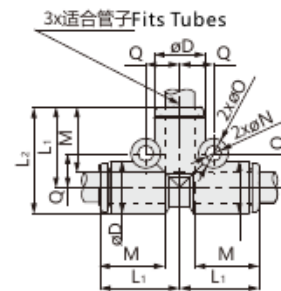

适合管子 外径 mm Fits Tubes Outside diameter	货号(PN)	型号(Model)	øD*	L <sub>1</sub>	L	M	Q	øO	øN	有效截面积mm Effective cross-sectional area		最小孔径 Minimum Hole Diameter	重量 Weight
										尼龙Nylon	聚氨酯Polyurethane		
ø2	1.Y13193	KQ2T02-00A	5.8	12.9	15.8	11.9	4.5	6	3.2	-	0.9	1.4	14g
ø3.2	1.Y13194	KQ2T23-00A	7.1	14.9	18.5	13.3	5.4	6	3.2	3.4	2.9	2.5	2.3g
ø4	1.Y03077	KQ2T04-00A	8.2	15.3	19.4	13.3	5.7	6	3.2	6.4	4.4	3	2.8g
ø6	1.Y03076	KQ2T06-00A	10.4	16.3	21.5	13.3	6.8	6	3.2	13.4	10.6	4.5	3.8g
ø8	1.Y00761	KQ2T08-00A	13.2	18.2	24.8	14.2	8.4	8	4.2	25.6	17.7	6	7g
ø10	1.Y13195	KQ2T10-00A	15.9	20.6	28.6	15.6	9.6	8	4.2	40	28.4	7.5	11g
ø12	1.Y13196	KQ2T12-00A	18.5	23	32.3	17	10.7	8	4.2	57.4	45.4	9	15.7g
ø16	1.Y13197	KQ2T16-00A	23.8	28.6	40.5	20.6	13.4	8	4.2	100	58.9	13	29.8g

KQ2系列 KQ2 series

T形接管:KQ2T

T-shaped connection :KQ2T

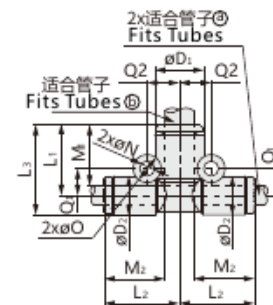

适合管子外径 mm Fits Tubes Outside diameter		货号(PN)	型号(Model)	øD*	øD <sub>2</sub>	L <sub>1</sub>	L <sub>2</sub>	L <sub>1</sub>	M <sub>1</sub>	M <sub>2</sub>	Q <sub>1</sub>	Q <sub>2</sub>	øO	øN	有效截面积mm Effective cross-sectional area		最小孔径 Minimum Hole Diameter	重量 Weight
ø <sub>1</sub>	ø <sub>2</sub>														尼龙Nylon	聚氨酯Polyurethane		
ø3.2	ø4	1.Y13198	KQ2T23-04A	8.2	7.1	14.9	15.3	18.5	13.3	13.3	5.4	5.8	6	3.2	3.8	3.5	2.5	2.6g
ø4	ø6	1.Y04160	KQ2T04-06A	10.4	8.2	15.3	16.3	19.4	13.3	13.3	5.7	6.8	6	3.2	7.1	6.6	3	3.3g
ø6	ø8	1.Y04159	KQ2T06-08A	13.2	10.4	17.2	17.3	22.4	14.2	13.3	7.3	8.4	8	4.2	16.4	16.4	4.5	5.3g
ø8	ø10	1.Y07561	KQ2T08-10A	15.9	13.2	19.6	19.2	26.2	15.6	14.2	8.4	9.6	8	4.2	36	27.2	6	8.3g
ø10	ø12	1.Y13199	KQ2T10-12A	18.5	15.9	22	21.6	30	17	15.6	9.6	10.7	8	4.2	56	44.5	7.5	12.2g
ø12	ø16	1.Y13200	KQ2T12-16A	23.8	18.5	26.6	25	35.9	20.6	17	10.7	13.4	8	4.2	108.5	74	9	20.1g

KQ2系列 KQ2 series

T形接管:KQ2T

T-shaped connection :KQ2T

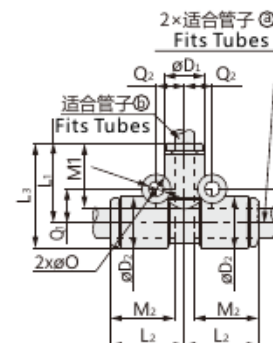

适合管子外径 mm Fits Tubes Outside diameter		货号(PN)	型号(Model)	øD*	øD <sub>2</sub>	L <sub>1</sub>	L <sub>2</sub>	L <sub>1</sub>	M <sub>1</sub>	M <sub>2</sub>	Q <sub>1</sub>	Q <sub>2</sub>	øO	øN	有效截面积mm Effective cross-sectional area		最小孔径 Minimum Hole Diameter	重量 Weight
ø <sub>1</sub>	ø <sub>2</sub>														尼龙Nylon	聚氨酯Polyurethane		
ø6	ø4	1.Y13201	KQ2T06-04A	8.2	10.4	16.3	15.3	21.5	13.3	13.3	6.8	5.7	6	3.2	6.4	4.4	3	2.5g
ø8	ø6	1.Y13202	KQ2T08-06A	10.4	13.2	17.3	17.2	23.9	13.3	14.2	8.4	7.3	8	4.2	13.4	10.6	4.5	6g
ø10	ø8	1.Y13203	KQ2T10-08A	13.2	15.9	19.2	19.6	27.2	14.2	15.6	9.6	8.4	8	4.2	25.6	17.7	6	9.5g
ø12	ø10	1.Y13204	KQ2T12-10A	15.9	18.5	21.6	22	30.9	15.6	17	10.7	9.6	8	4.2	40	28.4	7.5	13.4g

\* øD<sub>1</sub> 是最大直径。

\* øD<sub>1</sub> are maximum diameters.

Profile - SUS Tube  
型材、钢管

Stents Module  
支架模组

Quick Changer  
快换

Grip Module  
夹具组件

Air Nipper  
气动剪刀

Vacuum Module  
真空组件

Accessory Components  
附件

# 接头

## Connector

Profile, SUS Tube  
型材、钢管

Stents Module  
支架模组

Quick Changer  
快换

Grip Module  
夹具组件

Air Ripper  
气动剪刀

Vacuum Module  
真空组件

Accessory Components  
附件

KQ2系列 KQ2 series

Y形接管:KQ2U

Y-shaped connection :KQ2U

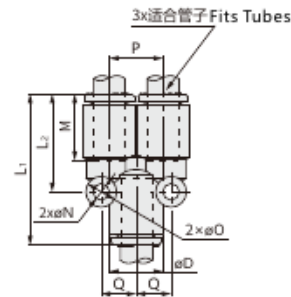

适合管子 外径 mm Fits Tubes Outside diameter	货号(PN)	型号(Model)	øD*	L1	L2	P	M	Q	øO	øN	有效截面积mm Effective cross-sectional area		最小 孔径 Minimum Hole Diameter	重量 Weight
											尼龙 Nylon	聚酰胺 Organosilicon		
ø2	1.Y13205	KQ2U02-00A	5.8	25.8	16.1	5.8	11.9	4.5	6	3.2	-	0.9	1.2	1.4g
ø3.2	1.Y13206	KQ2U23-00A	7.1	28.9	18	7.1	13.3	5.2	6	3.2	3.4	2.9	2.5	2.3g
ø4	1.Y02601	KQ2U04-00A	8.2	29	18.2	8.2	13.3	5.7	6	3.2	4.2	4.2	3	2.8g
ø6	1.Y02600	KQ2U06-00A	10.4	30.1	19.4	10.4	13.3	6.8	6	3.2	13.4	10.6	4.5	3.8g
ø8	1.Y03078	KQ2U08-00A	13.2	33.2	22.3	13.2	14.2	8.7	8	4.2	25.6	17.7	6	7g
ø10	1.Y13207	KQ2U10-00A	15.9	37.1	25	15.9	15.6	10.1	8	4.2	40	28.4	7.5	11g
ø12	1.Y13208	KQ2U12-00A	18.5	41.1	27.8	18.5	17	11.4	8	4.2	57.4	45.4	9	15.7g
ø16	1.Y13209	KQ2U16-00A	23.8	51.5	35	23.8	20.6	14	8	4.2	113	60	13	29.8g

\* øD 是最大直径。

\* øD are maximum diameters.

Kq2系列 KQ2 series

异径四管Y形接管:KQ2UD

Reducing four pipe Y-shaped connection :KQ2UD

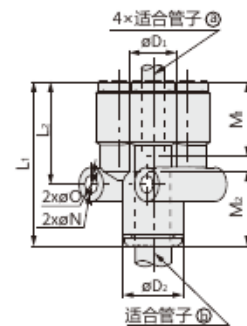
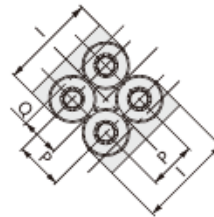

适合管子外径 mm Fits Tubes Outside diameter		货号(PN)	型号(Model)	øD1*	øD2	L1	L2	P	I	M1	M2	Q	øO	øN	有效截面积mm Effective cross-sectional area		最小 孔径 Minimum Hole Diameter	重量 Weight
①	②														尼龙 Nylon	聚酰胺 Organosilicon		
ø4	ø6	1.Y06909	KQ2UD04.06A	8.2	10.4	29.2	18.2	8.2	16.6	13.3	13.3	6.8	6	3.2	4.2	4.2	3	5.4g
ø6	ø8	1.Y08529	KQ2UD06.08A	10.4	13.2	32	20.5	10.4	21	13.3	14.2	8.2	6	3.2	13.4	10.6	4.5	8.1g

\* øD1、øD2 是最大直径。

\* øD1、øD2 are maximum diameters.

# 接头

## Connector

### AS系列 ASeries 弯头型节流阀 Elbow type throttle valve

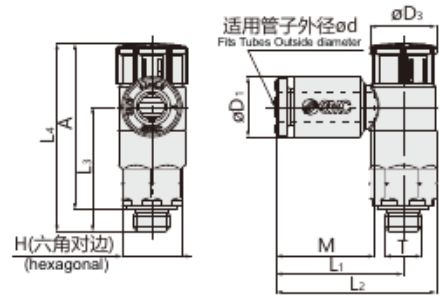

ød	型号(Model)	T	H	ØD <sub>1</sub>	ØD <sub>3</sub>	L <sub>1</sub>	L <sub>2</sub>	L <sub>3</sub>	L <sub>4</sub> <sup>(1)</sup>		A <sup>(2)</sup>		M	进气节流 (PN) Intake throttle	排气节流 (PN) Exhaust throttling	重量 Weight
									解锁 release	锁定 lock	解锁 release	锁定 lock				
ø2	As12□1F-M5-02A	M5x0.8	8	5.8	9.4	15.8	20.3	16.9	26.5	25.4	23.5	22.4	11.9	1.Y13218	1.Y13222	5g
ø3.2	As12□1F-M5-23A	M5x0.8	8	7.2	9.4	17.2	21.7	16.9	26.5	25.4	23.5	22.4	13.3	1.Y13219	1.Y13223	5g
ø4	As12□1F-M5-04A	M5x0.8	8	8.2	9.4	17.2	21.7	16.9	26.5	25.4	23.5	22.4	13.3	1.Y13220	1.Y13224	5g
ø6	As12□1F-M5-06A	M5x0.8	8	10.4	9.4	18.6	23.1	16.5	26.5	25.4	23.5	22.4	13.3	1.Y13221	1.Y03830	6g

□记号/0排气节流、1进气节流 Symbol/0 exhaust throttling, 1 intake throttling

(1)参考尺寸 Reference Size

(2)螺纹拧入后的参考尺寸 Reference dimension of R thread after screwing in

### AS系列 ASeries 弯头型节流阀(密封剂) Elbow type throttle valve(sealant)

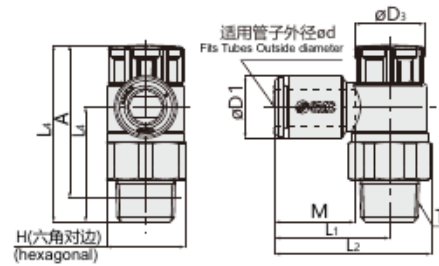

ød	型号(Model)	T	H	ØD <sub>1</sub>	ØD <sub>3</sub>	L <sub>1</sub>	L <sub>2</sub>	L <sub>3</sub>	L <sub>4</sub> <sup>(1)</sup>		A <sup>(2)</sup>		M	进气节流 (PN) Intake throttle	排气节流 (PN) Exhaust throttling	重量 Weight
									解锁 release	锁定 lock	解锁 release	锁定 lock				
ø3.2	AS22□1F-01-23SA	1/8	13	7.2	12	19.1	26.2	19.1	30.6	29.2	27.5	26.1	13.3	1.Y13225	1.Y13246	9g
ø4	AS22□1F-01-04SA	1/8	13	8.2	12	19.1	26.2	19.1	30.6	29.2	27.5	26.1	13.3	1.Y13226	1.Y13247	9g
ø6	AS22□1F-01-06SA	1/8	13	10.4	12	19.1	26.2	19.1	30.6	29.2	27.5	26.1	13.3	1.Y13227	1.Y05040	10g
ø8	AS22□1F-01-08SA	1/8	13	13.2	12	22.4	29.5	19.1	30.6	29.2	27.5	26.1	14.2	1.Y13228	1.Y13248	11g
ø10	AS22□1F-01-10SA	1/8	13	15.9	12	25.3	32.4	19.1	30.6	29.2	27.5	26.1	15.6	1.Y13229	1.Y13249	12g
ø3.2	AS22□1F-02-23SA	1/4	17	7.2	13	20.9	30.2	22.6	36.6	35	31.1	29.5	13.3	1.Y13230	1.Y13250	18g
ø4	AS22□1F-02-04SA	1/4	17	8.2	13	20.9	30.2	22.6	36.6	35	31.1	29.5	13.3	1.Y13231	1.Y13251	18g
ø6	AS22□1F-02-06SA	1/4	17	10.4	13	23.4	32.7	22.6	36.6	35	31.1	29.5	13.3	1.Y13232	1.Y06906	18g
ø8	AS22□1F-02-08SA	1/4	17	13.2	13	23.9	33.2	22.6	36.6	35	31.1	29.5	14.2	1.Y13233	1.Y08260	19g
ø10	AS22□1F-02-10SA	1/4	17	15.9	13	26.9	36.2	22.6	36.6	35	31.1	29.5	15.6	1.Y13234	1.Y13252	20g
ø6	AS32□1F-02-06SA	1/4	19	10.4	16.6	21.8	32.1	36.4	50	48.4	44.5	42.9	13.3	1.Y13235	1.Y13253	40g
ø8	AS32□1F-02-08SA	1/4	19	13.2	16.6	22.7	33	36.4	50	48.4	44.5	42.9	14.2	1.Y13236	1.Y13254	41g
ø10	AS32□1F-02-10SA	1/4	19	15.9	16.6	26.7	37	35.7	50	48.4	44.5	42.9	15.6	1.Y13237	1.Y13255	42g
ø12	AS32□1F-02-12SA	1/4	19	18.5	16.6	29.7	40	34.5	50	48.4	44.5	42.9	17	1.Y13238	1.Y13256	43g
ø6	AS32□1F-03-06SA	3/8	19	10.4	16.6	21.8	32.1	28.7	42.3	40.7	37.1	35.5	13.3	1.Y13239	1.Y13257	31g
ø8	AS32□1F-03-08SA	3/8	19	13.2	16.6	22.7	33	28.7	42.3	40.7	37.1	35.5	14.2	1.Y13240	1.Y13258	31g
ø10	AS32□1F-03-10SA	3/8	19	15.9	16.6	26.7	37	28	42.3	40.7	37.1	35.5	15.6	1.Y13241	1.Y13259	32g
ø12	AS32□1F-03-12SA	3/8	19	18.5	16.6	29.7	40	26.8	42.3	40.7	37.1	35.5	17	1.Y13242	1.Y13260	34g
ø10	AS42□1F-04-10SA	1/2	24	15.9	18.8	27.4	40.3	36.2	50.8	49.2	43.7	42.1	15.6	1.Y13243	1.Y13261	54g
ø12	AS42□1F-04-12SA	1/2	24	18.5	18.8	30.8	43.7	35.1	50.8	49.2	43.7	42.1	17	1.Y13244	1.Y13262	56g
ø16	AS42□1F-04-16SA	1/2	24	23.8	18.8	34.8	47.7	32.7	50.8	49.2	43.7	42.1	20.6	1.Y13245	1.Y13263	60g

□记号/0排气节流、1进气节流 Symbol/0 exhaust throttling, 1 intake throttling

(1)参考尺寸 Reference Size

(2)螺纹拧入后的参考尺寸 Reference dimension of R thread after screwing in

Profile- SUS Tube  
型材、钢管

Stents Module  
支架模组

Quick Changer  
快换

Grip Module  
夹具组件

Air Nipper  
气动剪刀

Vacuum Module  
真空组件

Accessory Components  
附件

# 接头

## Connector

AS系列 ASseries

直通型节流阀

Straight-through throttle valve

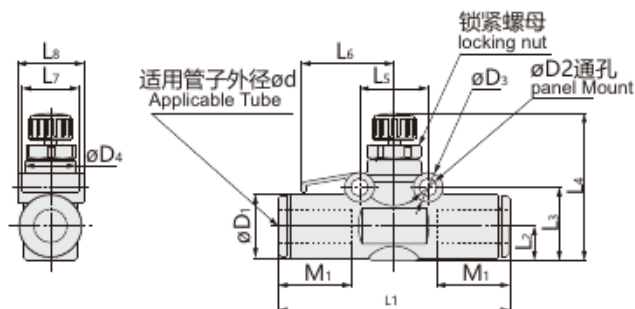

ød	货号(PN)	型号(Model)	ØD <sub>1</sub>	ØD <sub>2</sub>	ØD <sub>3</sub>	ØD <sub>4</sub>	L <sub>1</sub>	L <sub>2</sub>	L <sub>3</sub>	L <sub>4</sub> <sup>(1)</sup>		L <sub>5</sub>	L <sub>6</sub>	L <sub>7</sub>	L <sub>8</sub>	M <sub>1</sub>	重量 Weight
										MAX.	MIX.						
ø2	1Y13264	AS1002F-02	6	3.2	5	6	25.4	3.4	7.9	20.9	18.4	11	9.8	5	6.7	8.8	3g
ø3.2	1Y13265	AS1002F-23	8.4	3.3	5.5	9.1	36	4.4	11.1	23.8	21	11	15.4	8.8	9.8	12.7	5g
ø4	1Y04457	AS1002F-04	9.3	3.3	5.5	9.1	37	5.1	11.8	24.5	21.7	11	15.4	8.8	10.1	12.7	5.5g
ø6	1Y04777	AS1002F-06	11.6	3.3	5.5	9.1	39.5	6.1	12.8	25.5	22.7	11	15.4	8.8	12.3	13.5	6.5g
ø4	1Y13266	AS2002F-04	9.3	3.3	5.5	10	40.7	5.2	12.3	28.9	25.4	12.6	17	10.5	11.5	12.7	8.5g
ø6	1Y13267	AS2002F-06	11.6	3.3	5.5	10	42.5	6.3	13.4	30	26.5	12.6	17	10.5	12.3	13.5	9.5g
ø6	1Y13268	AS2052F-06	12.8	4.3	7.8	14	53.2	6.7	16.3	34.5	29.5	17	22.8	12	15.7	17	19g
ø8	1Y13269	AS2052F-08	15.2	4.3	7.8	14	57.2	8	17.6	35.8	30.8	17	22.8	12	16.1	18	22g
ø6	1Y13270	AS3002F-06	13.2	4.3	8	19.3	59	7.4	19.3	38.6	33.6	22	25	12	20.5	17	36g
ø8	1Y13271	AS3002F-08	15.2	4.3	8	19.3	65	8.2	20.1	39.4	34.4	22	25	12	20.5	18	38g
ø10	1Y13272	AS3002F-10	18.5	4.3	8	19.3	70.8	9.8	21.7	41	36	22	25	12	20.5	21	42g
ø12	1Y13273	AS3002F-12	20.9	4.3	8	19.3	76	10.9	22.8	42.1	37.1	22	25	12	22.1	22	44g
ø10	1Y13274	AS4002F-10	18.5	4.3	8	25	76.9	10.3	22.7	51.6	44.1	28	33	14	26.2	21	76g
ø12	1Y13275	AS4002F-12	21.7	4.3	8	25	81.3	11.3	23.7	52.6	45.1	28	33	14	26.2	22	82g

□记号/0排气节流、1进气节流 Symbol/0 exhaust throttling, 1 intake throttling

(1)参考尺寸 Reference Size

(2)螺纹拧入后的参考尺寸 Reference dimension of R thread after screwing in

Profile, SUS Tube  
型材、铜管

Stents Module  
支架模组

Quick Changer  
快换

Grip Module  
夹具组件

Air Nipper  
气动剪刀

Vacuum Module  
真空组件

Accessory Components  
附件

# 接头

## Connector

KC系列 KC series

直通接头:KCH

Straight joint:KCH



<M5の場合>

<Rの場合>

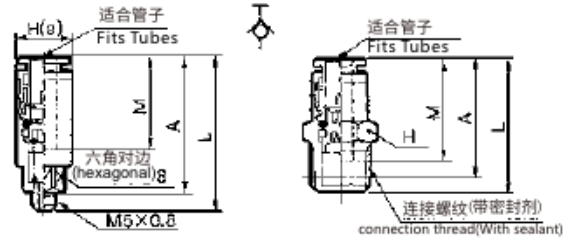

<M5の場合>

<Rの場合>

适合管子 外径 mm Fits Tubes Outside diameter	货号(PN)	型号(Model)	连接螺纹 M Connection thread	H (六角对边 (hexagonal))	L	A	M	有效截面积mm <sup>2</sup> Effective cross-sectional area		重量 Weight
								尼龙Nylon	聚四氟乙烯Organosilicon	
ø4	1.Y03525	KCH04-M5	M5 X 0.8	9.8	30.8	27.3	18	2.1	2.1	8g
	1.Y13286	KCH04-01S	1/8	10	26.1	22.1	18	2.6	2.6	8g
ø6	1.Y03524	KCH06-M5	M5 X 0.8	11.8	32.4	28.9	19.5	2.4	2.4	10g
	1.Y13287	KCH06-01S	1/8	12	37.5	33.4	19	6.8	6.8	16g
ø8	1.Y13288	KCH08-01S	1/8	14	42.4	38.4	21.5	16.2	13.1	20g

※ R螺纹拧入后的参考尺寸

※ R reference dimension of R thread after screwing in

KQ2系列 KQ2 series

堵头:KQ2P

Plug :KQ2P

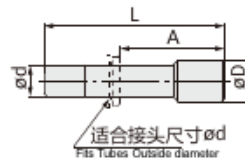

适合管子 尺寸øD Fits Tubes Outside diameter	货号(PN)	型号(Model)	øD*	L	A	重量 Weight
ø2	1.Y13210	KJP-02	3	17	10.4	0.1g
ø3.2	1.Y13211	KQ2P-23	5	31.5	18.2	1g
ø4	1.Y13212	KQ2P-04	6	32	18.7	1g
ø6	1.Y13213	KQ2P-06	8	35	21.7	1g
ø8	1.Y13214	KQ2P-08	10	39	24.8	2g
ø10	1.Y13215	KQ2P-10	12	43	27.4	3.5g
ø12	1.Y13216	KQ2P-12	14	45.5	28.5	5g
ø16	1.Y13217	KQ2P-16	20.9	47	26.4	8g

# 软管 Hoses

聚氨酯软管可通过快速接头输送压缩空气。  
Polyurethane hose for compressed air suitable for use with push-in fittings.

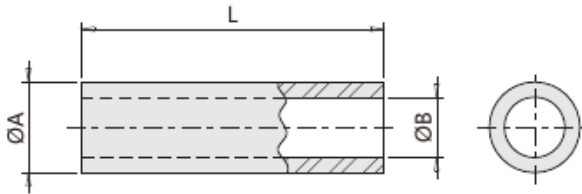

技术规格  
Technical characteristics  
T = -15 ~ +60°C  
P = 0.8MPa



\* 每盒长度为 100 米  
\* Each box is 100 meters in length.

货号(PN)	型号(Model)	颜色(Colour)	A [mm]	B [mm]	L [m]	Lm [g/m]
1.Y00824	AH4B	黑色 / Black	4	2.5	100	9g
1.Y03687	AH4BU	蓝色 / Blue	4	2.5	100	9g
1.Y00823	AH4G	绿色 / Green	4	2.5	100	9g
1.Y03686	AH4T	透明色 / Transparent	4	2.5	100	9g
1.Y00821	AH4Y	黄色 / Yellow	4	2.5	100	9g
1.Y00822	AH4R	红色 / Red	4	2.5	100	9g
1.Y05661	AH4O	橙色 / Orange	4	2.5	100	9g
1.Y00830	AH6B	黑色 / Black	6	4	100	19g
1.Y00829	AH6BU	蓝色 / Blue	6	4	100	19g
1.Y00825	AH6G	绿色 / Green	6	4	100	19g
1.Y00827	AH6T	透明色 / Transparent	6	4	100	19g
1.Y00828	AH6Y	黄色 / Yellow	6	4	100	19g
1.Y00826	AH6R	红色 / Red	6	4	100	19g
1.Y04640	AH6O	橙色 / Orange	6	4	100	19g
1.Y04478	AH8B	黑色 / Black	8	5	100	36g
1.Y00831	AH8BU	蓝色 / Blue	8	5	100	36g
1.Y04476	AH10B	黑色 / Black	10	6.5	100	54g
1.Y05660	AH10BU	蓝色 / Blue	10	6.5	100	54g

- A [外径 - Outer diameter]
- B [内径 - Inner diameter]
- L [长度 - Length]
- Lm [线重 - Linear mass]
- P [操作压力范围 - Operating pressure range]
- T [操作温度范围 - Operating temperature range]

Profile, SUS Tube  
型材、钢管

Stents Module  
支架模组

Quick Changer  
快换

Grip Module  
夹具组件

Air Nipper  
气动剪刀

Vacuum Module  
真空组件

Accessory Components  
附件



型号(Model)	货号(PN)	页码(Page)
型材、钢棒 Profile、SUS Tube		
PST8-1500	4.Y00040	1
PST12-1500	4.Y00021	1
PST20-1500	4.Y00022	1
PAT20-1000	4.Y00468	1
PAT20-2000	4.Y10972	1
PAT30-1000	4.Y00469	1
PAT30-2000	4.Y10973	1
PAT25-1000	4.Y10950	1
PAT25-2000	4.Y10974	1
PAT40-1000	4.Y00538	1
PAT40-2000	4.Y10975	1
PCT8-1000	4.Y10960	2
PCT8-2000	4.Y10961	2
PCT12-1000	4.Y10962	2
PCT12-2000	4.Y10963	2
PCT20-1000	4.Y10964	2
PCT20-2000	4.Y10965	2
PCT25-1000	4.Y10966	2
PCT25-2000	4.Y10967	2
PCT30-1000	4.Y10968	2
PCT30-2000	4.Y10969	2
PCT40-1000	4.Y10970	2
PCT40-2000	4.Y10971	2
P08RD	1.Y03375	2
P12GY	1.Y03636	2
P12BU	1.Y03638	2
P12BK	1.Y03640	2
P20GY	1.Y03637	2
P20BU	1.Y03639	2
P20BK	1.Y03641	2
P30BK	1.Y20001	2
P25BK	1.Y10988	2
P40BK	1.Y10987	2
PEP1818-1000	4.Y00075	3
PEP2510-1000	4.Y00076	3
PEP2518-1000	4.Y00455	3
PEP2525-1000	4.Y00050	3
PEP2525-2000	4.Y00051	3
PEP5025-1000	4.Y00056	3
PEP5025-2000	4.Y00057	3
PEP4040-1000	4.Y00052	3
PEP4040-2000	4.Y00053	3
PEP3030-1000	4.Y00540	3
PEP3030-2000	4.Y00541	3
PEP3636-1000	4.Y00054	4
PEP3636-1500	4.Y00484	4
PEP3636-2000	4.Y00055	4
P1818	4.Y00517	3
P2010	4.Y00518	3
P2518	4.Y00069	3
P2525	4.Y00070	3
P5025	4.Y00071	3
P4040	4.Y00072	3
P3030	4.Y00542	3
P3636	4.Y00073	4
PTN-M4	7.Y00651	5
PTN-M5	7.Y00425	5
PTN-M6	7.Y00652	5
PTN-M4P8	7.Y00653	5
PTN-M5P10	7.Y00654	5
PTN-M5P15	7.Y00655	5
PTN-M5P17	7.Y00656	5
PTN-M5P22	7.Y00657	5
PTN-M5P25	7.Y00658	5
PTN-M5P28	7.Y00659	5
PTN-M5P30	7.Y00660	5

型号(Model)	货号(PN)	页码(Page)
PTN-M5P35	7.Y00661	5
PTN-M5P40	7.Y00662	5
PTN-M5P50	7.Y00663	5
PTN-M5P60	7.Y00664	5
PTN-M5P90	7.Y00665	5
PTN-M5R	7.Y00805	5
PTC-M4L10	1.Y03908	6
PTC-M4L12	1.Y03848	6
PTC-M4L14	1.Y02752	6
PTC-M4L16	1.Y04073	6
PTC-M4L18	1.Y05846	6
PTC-M4L20	1.Y04000	6
PTC-M4L22	1.Y06307	6
PTC-M4L25	1.Y05319	6
PTC-M5L10	1.Y04294	6
PTC-M5L12	1.Y03850	6
PTC-M5L14	1.Y04528	6
PTC-M5L16	1.Y03849	6
PTC-M5L18	1.Y05925	6
PTC-M5L20	1.Y03909	6
PTC-M5L22	1.Y06257	6
PTC-M5L25	1.Y03851	6
PTC-M5L30	1.Y04469	6
PTC-M5L35	1.Y04580	6
PTC-M5L40	1.Y04898	6
PTC-M5L50	1.Y04968	6
PTC-M5L60	1.Y05391	6
PTC-M6L10	1.Y04288	6
PTC-M6L12	1.Y03910	6
PTC-M6L14	1.Y04153	6
PTC-M6L16	1.Y02753	6
PTC-M6L18	1.Y07729	6
PTC-M6L20	1.Y04076	6
PTC-M6L25	1.Y06227	6
PTC-M6L30	1.Y04001	6
PTC-M6L35	1.Y03911	6
PTS-M4	1.Y03853	7
PTS-M5	1.Y03852	7
PTS-M6	1.Y03854	7
PTD-M4P8	4.Y00522	7
PTD-M5P10	4.Y00523	7
PTD-M5P15	4.Y00524	7
PTD-M5P17	4.Y00525	7
PTD-M5P22	4.Y00526	7
PTD-M5P25	4.Y00527	7
<b>支架模组    tents Module</b>		
SFP-S2550	7.Y00641	8
SFP-S25100	7.Y00642	8
SFP-S40160	7.Y00643	8
SFP-L2550	7.Y00647	9
SFP-L2575	7.Y00648	9
SFP-L40120	7.Y00649	9
SFP-T2550	7.Y00644	10
SFP-T25100	7.Y00645	10
SFP-T40120	7.Y00646	10
SFP-A60	7.Y00637	11
SFP-A90	7.Y00638	11
SFP-A70	7.Y00639	11
SFP-A50	7.Y00640	12
SFP-50	7.Y00636	13
SMBA-1818	7.Y00290	14
SMBA-1825	7.Y00291	14
SMBA-2020	7.Y00245	14
SMBA-2525	7.Y00194	14
SMBA-3030	7.Y00193	14
SMBA-5050	7.Y00011	14
SMBA-2550	7.Y00292	14

型号(Model)	货号(PN)	页码(Page)
SMBA-4040	7.Y00246	14
SMBA-8080	7.Y00355	14
SMBA-4080	7.Y00293	14
SMBA-2580	7.Y00294	14
SMBA-2540	7.Y00356	14
SMBA-3025	7.Y00690	14
SMBB-1818	7.Y00295	15
SMBB-1825	7.Y00817	15
SMBB-2525	7.Y00012	15
SMBB-5025	7.Y00339	15
SMBB-2550	7.Y00340	15
SMBB-3030	7.Y00163	15
SMBC-1025	7.Y00296	16
SMBC-1432	7.Y00297	16
SMBC-2038	7.Y00013	16
SMBC-3050	7.Y00226	16
SMBC-5070	7.Y00225	16
SMBC8-1025	7.Y02033	17
SMBC8-1432	7.Y02034	17
SMBC8-2038	7.Y02035	17
SMBD-2550	7.Y00227	18
SMBD-5070	7.Y00228	18
SMBD2-7625	7.Y00426	19
SMBD2-12025	7.Y00427	19
SMBD2-13025	7.Y00428	19
SMBD2-7650	7.Y00429	19
SMBD2-12050	7.Y00430	19
SMBD2-13050	7.Y00431	19
SMBD3-2525	7.Y00812	20
SMBD3-2550	7.Y00813	20
SMBD3-4040	7.Y00814	20
SMBD3-4080	7.Y00815	20
SMBE-1010	7.Y00300	21
SMBE-1014	7.Y00301	21
SMBE-1210	7.Y00775	21
SMBE-1214	7.Y00864	21
SMBE-1414	7.Y00302	21
SMBE-2014	7.Y00014	21
SMBE-2022	7.Y00304	21
SMBE1-0840	7.Y00694	22
SMBE1-1040	7.Y00201	22
SMBE1-1240	7.Y00695	22
SMBE1-1440	7.Y00200	22
SMBE1-1450	7.Y00199	22
SMBE1-2060	7.Y00015	22
SMBE1-3060	7.Y00724	22
SMBE2-1040	7.Y00725	23
SMBE2-1240	7.Y00777	23
SMBE2-1450	7.Y00307	23
SMBE2-2060	7.Y00308	23
SMBE2-3060	7.Y00309	23
SMBE8-1050	7.Y02014	24
SMBE8-1460	7.Y02015	24
SMBE8-2060	7.Y02012	24
SMBE3-1020	7.Y00341	25
SMBE3-1220	7.Y00795	25
SMBE3-1430	7.Y00342	25
SMBE3-2040	7.Y00343	25
SMBE3-3050	7.Y00344	25
SMBE4-1412	7.Y00224	26
SMBE4-2012	7.Y00223	26
SMBE4-2020	7.Y00181	26
SMBE4-3012	7.Y00222	26
SMBE4-3020	7.Y00221	26
SMBE5-G1840	7.Y00310	27
SMBE5-G1860	7.Y00311	27
SMBE5-M1040	7.Y00312	27



# 索引 Index

型号(Model)	货号(PN)	页码(Page)
SMBE5-M1060	7.Y00313	27
SMBE5-M1240	7.Y00314	27
SMBE5-M1260	7.Y00315	27
SMBE5-M1440	7.Y00316	27
SMBE5-M1460	7.Y00317	27
SMBE5-M1640	7.Y00320	27
SMBE5-M1660	7.Y00321	27
SMBE5-M2040	7.Y00322	27
SMBE5-M2060	7.Y00323	27
SMBE6-1040	7.Y00357	28
SMBE6-1240	7.Y00358	28
SMBE6-1440	7.Y00359	28
SMBE6-1640	7.Y00360	28
SMBE6-2040	7.Y00361	28
SMBE6-2240	7.Y00362	28
SMBE6-2540	7.Y00363	28
SMBE6-1028	7.Y00364	28
SMBE6-1228	7.Y00365	28
SMBE6-1428	7.Y00366	28
SMBE6-1628	7.Y00367	28
SMBE6-2028	7.Y00368	28
SMBE6-2228	7.Y00369	28
SMBE6-2528	7.Y00370	28
SMBE7-0856	7.Y00062	29
SMBE7-1256	7.Y00021	29
SMBE7-2056	7.Y00006	29
SMBE9-1020	7.Y02036	29
SMBE9-1430	7.Y02037	29
SMBE9-2040	7.Y02038	29
SMB-10M5-02G18	7.Y00153	30
SMB-08M5-02G18	7.Y00154	30
SMB-10M5	7.Y00155	30
SMB-08M5	7.Y00156	30
SMB-06M5	7.Y00157	30
SMB-14M5	7.Y00167	30
SMB-5G18	7.Y00229	31
SMB1-5G18	7.Y01020	31
SMB2-5G18	7.Y01022	31
SMB-9G18	7.Y00231	32
SMB1-9G18	7.Y01021	32
SMB2-9G18	7.Y01023	32
SMB-D5G18	7.Y00230	33
SMB1-D5G18	7.Y01024	33
SMB2-D5G18	7.Y01025	33
SMB-A5G18	7.Y00240	34
SMB-A5G14	7.Y00241	34
SMBY-1050M5	7.Y02063	35
SMBY-1095M5	7.Y02064	35
SMBY-1452G18	7.Y02065	35
SMBY-1497G18	7.Y02066	35
SMBY-2053G14	7.Y02067	35
SMBY-2098G14	7.Y02068	35
SMBY12-50	7.Y00736	35
SMBY12-100	7.Y00735	35
SMBY14-50	7.Y00733	35
SMBY14-100	7.Y00734	35
SMBY20-50	7.Y00732	35
SMBY20-100	7.Y00731	35
SMBY20-150	7.Y00462	35
SMBY25-100	7.Y01027	35
SMBY30-50	7.Y00729	35
SMBY30-100	7.Y00730	35
SMBY30-150	7.Y00463	35
SMBT1-M1412	7.Y00028	36
SMBP-0808	7.Y00042	36
SMBP-0812	7.Y00043	36
SMBP-1212	7.Y00044	36

型号(Model)	货号(PN)	页码(Page)
SMBP-2012	7.Y00045	36
SMBP-2020	7.Y00046	36
SMBT-0808	7.Y00025	37
SMBT-1208	7.Y00026	37
SMBT-1212	7.Y00020	37
SMBT-1214	7.Y00794	37
SMBT-2012	7.Y00027	37
SMBT-2020	7.Y00005	37
SMBT-1414	7.Y01002	37
SMBT-2520	7.Y00998	37
SMBT-2525	7.Y00999	37
SMBT-3025	7.Y02670	37
SMBT-4020	7.Y01059	37
SMBT-4025	7.Y01004	37
SMBT-4030	7.Y02058	37
SMBT-4040	7.Y01003	38
SMBT2-1212	7.Y00192	38
SMBT2-2020	7.Y00185	38
SMBT2-4040	7.Y02020	38
SMBT2-3030	7.Y02021	38
SMBT2-2525	7.Y02022	38
SMBT2-4025	7.Y02025	38
SMBT2-4020	7.Y02026	38
SCD-2010	7.Y00329	39
SCD-2014	7.Y00330	39
SCD-3020	7.Y01049	39
SCD-2020	7.Y00233	39
SCD-3030	7.Y01050	39
SMBF1-0808	7.Y00036	40
SMBF1-0812	7.Y00037	40
SMBF1-1208	7.Y00038	40
SMBF1-1212	7.Y00003	40
SMBF1-1220	7.Y00039	40
SMBF1-2012	7.Y00040	40
SMBF1-2020	7.Y00041	40
SMBF-0808	7.Y00029	40
SMBF-0812	7.Y00030	40
SMBF-1208	7.Y00031	40
SMBF-1212	7.Y00032	40
SMBF-1220	7.Y00033	40
SMBF-2012	7.Y00034	40
SMBF-2020	7.Y00035	40
SMBT3-2020	7.Y00047	41
SMBG1-8M5	7.Y00057	41
SMBG1-8M6	7.Y00058	41
SMBG1-12M5	7.Y00059	41
SMBG1-12M6	7.Y00060	41
SMBG1-12G18	7.Y00061	41
SMBJ1-5	7.Y00070	42
SMBJ2-6	7.Y00071	42
SMBT5-8	7.Y00072	43
SMBT5-12	7.Y00073	43
SMBT6-12	7.Y00074	43
SMBM-10	7.Y00740	44
SMBM-16	7.Y00741	44
SMBM-20	7.Y00728	44
SMBM-25	7.Y00739	44
SMBM-32	7.Y00738	44
SMBM-40	7.Y00737	44
SMBU-12	7.Y00082	45
SMBU2-20	7.Y00255	45
SMBU8-20	7.Y00090	45
SMBU3-8	7.Y00085	46
SMBU4-12	7.Y00086	46
SMBU5-20	7.Y00087	46
SMBU6-8	7.Y00088	47
SMBU7-12	7.Y00089	47

型号(Model)	货号(PN)	页码(Page)
SMBT9-12	7.Y00081	47
SMBK1-8T10	7.Y00091	48
SMBK1-12T10	7.Y00092	48
SMBK1-20T10	7.Y00093	48
SMBK1-8T16	7.Y00094	48
SMBK1-12T16	7.Y00095	48
SMBK1-20T16	7.Y00096	48
SMBU9-M10	7.Y01051	48
SCF1-40M3	7.Y00115	49
SCF1-40G18	7.Y00118	49
SCF1-70M3	7.Y00129	49
SCF1-70G18	7.Y00132	49
SCF2-40M5	7.Y00173	49
SCF2-40M6	7.Y00117	49
SCF2-70M5	7.Y00130	49
SCF2-70M6	7.Y00131	49
SCF3-40M10	7.Y00119	49
SCF3-40M12	7.Y00120	49
SCF3-40M17	7.Y00121	49
SCF3-70M10	7.Y00133	49
SCF3-70M12	7.Y00134	49
SCF3-70M17	7.Y00135	49
SCF4-0840W12	7.Y00122	50
SCF4-0840W16	7.Y00123	50
SCF4-1240W16	7.Y00004	50
SCF4-2040W25	7.Y00124	50
SCF4-0870W12	7.Y00136	50
SCF4-0870W16	7.Y00137	50
SCF4-1270W16	7.Y00138	50
SCF4-2070W25	7.Y00139	50
SCF5-0840W16	7.Y00125	50
SCF5-0840W12	7.Y00126	50
SCF5-1240W16	7.Y00127	50
SCF5-2040W25	7.Y00128	50
SCF5-0870W16	7.Y00140	50
SCF5-0870W12	7.Y00141	50
SCF5-1270W16	7.Y00142	50
SCF5-2070W25	7.Y00143	50
SMBS-8T10	7.Y00064	50
SMBS-12T10	7.Y00065	50
SMBS-20T10	7.Y00066	50
SMBS-8T16	7.Y00067	50
SMBS-12T16	7.Y00001	50
SMBS-20T16	7.Y00068	50
SMBR2-M10	7.Y00099	51
SMBR2-M12	7.Y00100	51
SMBR4-0808M4	7.Y00103	51
SMBR4-1208M4	7.Y00110	51
SMBR4-1212M4	7.Y00019	51
SMBR4-1212M4L	7.Y00268	51
SMBR4-1420M6	7.Y00461	51
SMBR4-2020M6	7.Y00007	51
SMBR4-2020M6L	7.Y00206	51
SMBR5-1208	7.Y00111	51
SMBR5-0808	7.Y00104	51
SMBR5-1212	7.Y00112	51
SMBR7-0808	7.Y00113	52
SMBR7-1212	7.Y00114	52
SMBR-46	7.Y00063	52
SMBR1-12	7.Y00098	52
SCC-20G18	7.Y00236	53
SCC-20M16	7.Y00234	53
SVA-G18	7.Y00235	54
SVA-G14	7.Y00237	54
SVB-M5	7.Y00242	55
SVB-G18	7.Y00244	55
SVB-G14	7.Y00243	55



型号(Model)	货号(PN)	页码(Page)
SVC-M5	7.Y00328	56
SVC-G18	7.Y00238	56
SVC-G14	7.Y00239	56
SVD-M5	7.Y00416	57
SVD-G18	7.Y00417	57
SVD-G14	7.Y00418	57
SVE-M51030	7.Y00410	58
SVE-M51060	7.Y00411	58
SVE-M51090	7.Y00412	58
SVE-M51230	7.Y00772	58
SVE-M51260	7.Y00773	58
SVE-M51290	7.Y00774	58
SVE-G181440	7.Y00413	58
SVE-G181480	7.Y00414	58
SVE-G1814120	7.Y00415	58
SVE-G142050	7.Y00008	58
SVE-G1420100	7.Y00009	58
SVE-G1420150	7.Y00010	58
SCA1-1010L30	7.Y00398	59
SCA1-1010L60	7.Y00399	59
SCA1-1010L90	7.Y00400	59
SCA1-1212L30	7.Y00769	59
SCA1-1212L60	7.Y00770	59
SCA1-1212L90	7.Y00771	59
SCA1-1414L40	7.Y00401	59
SCA1-1414L80	7.Y00402	59
SCA1-1414L120	7.Y00403	59
SCA1-2020L50	7.Y00404	59
SCA1-2020L100	7.Y00405	59
SCA1-2020L150	7.Y00406	59
SCA1-3030L80	7.Y00407	59
SCA1-3030L140	7.Y00408	59
SCA1-3030L200	7.Y00409	59
SCA2-2020L50	7.Y00996	59
SCA2-2020L100	7.Y01000	59
SCA2-2020L150	7.Y00997	59
SCA2-2525L50	7.Y02030	59
SCA2-2525L100	7.Y02031	59
SCA2-2525L150	7.Y02032	59
SCA2-3030L80	7.Y01006	59
SCA2-3030L140	7.Y01005	59
SCA2-3030L200	7.Y01001	59
SCE-NR10	7.Y00470	60
SCE-NR20	7.Y00331	60
SCE-NR30	7.Y00261	60
SCE-NR50	7.Y00742	60
SCE1-NS20	7.Y00692	61
SCE1-NS30	7.Y00693	61
SCE2-05	7.Y00796	62
SCE2-1015	1.Y00094	62
SCE2-25	7.Y00633	63
SCE3-N10	7.Y00075	63
SCE3-N20	7.Y00076	63
SCE3-N30	7.Y00077	63
SCE4-NR(L,R)	7.Y00868	64
SCE4-NR30	7.Y00146	64
SCE4-NR20	7.Y00147	64
SCE4-NR10	7.Y00148	64
SCE-NR20-D10	7.Y00946	65
SCE-NR20-D12	7.Y00947	65
SCE-NR30-D10	7.Y00948	65
SCE-NR30-D12	7.Y00949	65
SMBH1-8M5	7.Y00051	66
SMBH1-8M6	7.Y00052	66
SMBH1-12M5	7.Y00053	66
SMBH1-12M6	7.Y00002	66
SMBH1-12M8	7.Y00054	66

型号(Model)	货号(PN)	页码(Page)
SMBH1-20M6	7.Y00055	66
SMBH1-20M8	7.Y00056	66
SMBE7-18M5	7.Y00869	66
SMBE7-18M6	7.Y00870	66
SMBE7-25M5	7.Y00871	66
SMBE7-25M6	7.Y00872	66
SEA-1010L60	7.Y00388	67
SEA-1212L60	7.Y00776	67
SEA-1414L40	7.Y00389	67
SEA-1414L80	7.Y00390	67
SEA-1414L120	7.Y00391	67
SEA-2020L50	7.Y00392	67
SEA-2020L100	7.Y00393	67
SEA-2020L150	7.Y00394	67
SEA-3030L80	7.Y00395	67
SEA-3030L140	7.Y00396	67
SEA-3030L200	7.Y00397	67
SEAH-2020L50	7.Y00350	68
SEAH-2020L100	7.Y00351	68
SEAH-2020L150	7.Y00166	68
SEAH-3030L80	7.Y00352	68
SEAH-3030L140	7.Y00353	68
SEAH-3030L200	7.Y00354	68
SEAV-M510L45	7.Y00432	69
SEAV-M510L90	7.Y00433	69
SEAV-G1814L60	7.Y00258	69
SEAV-G1814L120	7.Y00434	69
SEAV-G1820L78	7.Y00435	69
SEAV-G1820L153	7.Y00247	69
SEAV-G1420L75	7.Y00436	69
SEAV-G1420L150	7.Y00437	69
SBNA-8M5	7.Y00271	70
SBNA-8M6	7.Y00272	70
SBNA-12M5	7.Y00273	70
SBNA-12M10	7.Y00274	70
SBNA-20M12	7.Y00276	70
SBNA-20M17	7.Y00277	70
SBNB-12PT18	7.Y00275	70
SBNB-20PT18	7.Y00278	70
SBND-1208	7.Y00280	70
SBND-2012	7.Y00281	70
SBND-2008	7.Y00282	70
<b>快换 Quick Changer</b>		
QCA-05R	8.Y00355	78
QCA-05G	8.Y00356	78
QCA-05R-SP	8.Y00355-SP	78
QCA-05R-SN	8.Y00355-SN	78
QCA-05R1-SN	8.Y01066	80
QCA-05G1	8.Y01067	80
QCA-15R	8.Y00353	82
QCA-15G	8.Y00354	82
QCA-15R-SP	8.Y00353-SP	82
QCA-15R-SN	8.Y00353-SN	82
QCA-25R	8.Y00460	84
QCA-25G	8.Y00461	84
QCA-25R-SP	8.Y00460-SP	84
QCA-25R-SN	8.Y00460-SN	84
QCA-35RS	8.Y01311	86
QCA-35RS-SP	8.Y01316	86
QCA-35RS-SN	8.Y01317	86
QCA-35R	8.Y00351	87
QCA-35G	8.Y00352	87
QCA-35R-SP	8.Y00351-SP	87
QCA-35R-SN	8.Y00351-SN	87
QCA-50R	8.Y00349	90
QCA-50G	8.Y00350	90
QCA-50R-SP	8.Y00349-SP	90

型号(Model)	货号(PN)	页码(Page)
QCA-50R-SN	8.Y00349-SN	90
QCA-S50RS-SP	8.Y01307	93
QCA-S50RS-SN	8.Y01312	93
QCA-S50R-SP	8.Y00436	94
QCA-S50G	8.Y00405	94
QCA-100R-SP	8.Y00362-SP	97
QCA-100R-SN	8.Y00362-SN	97
QCA-100G	8.Y00363	97
QCA-S100RS-SP	8.Y01308	100
QCA-S100RS-SN	8.Y01313	100
QCA-S100R-SP	8.Y00437	101
QCA-S100G	8.Y00426	101
QCA-S150RS-SP	8.Y01309	104
QCA-S150RS-SN	8.Y01314	104
QCA-S150R-SP	8.Y01013	105
QCA-S150G	8.Y01014	105
QCA-200R-SP	8.Y00272-SP	108
QCA-200R-SN	8.Y00272-SN	108
QCA-200G	8.Y00357	108
QCA-200RS-SP-D1	8.Y01310	111
QCA-200RS-SN-D1	8.Y01315	111
QCA-200R-SP-D1	8.Y00272-SP-D1	112
QCA-200R-SN-D1	8.Y00272-SN-D1	112
QCA-200G-D1	8.Y00357-D1	112
QCA-300R-SP	8.Y01102	115
QCA-300G	8.Y01052	115
QCSM-15R1	7.Y00965	120
QCSM-15G1	7.Y00966	120
QCSM-15R1-1000	7.Y02097	121
QCSM-15G1-1000	7.Y02098	121
QCSM-TSR1-SP	7.Y03380	122
QCSM-TSR1-SN	7.Y03901	122
QCSM-TSG1	7.Y03881	122
QCSM-TSR2-SP	7.Y03882	123
QCSM-TSR2-SN	7.Y03902	123
QCSM-TSG2	7.Y03883	123
QCSM-15R2	7.Y00468	124
QCSM-15G2	7.Y00469	124
QCSM-19R	7.Y00954	125
QCSM-19G	7.Y00955	125
QCSM-19R1	7.Y02123	126
QCSM-26G	7.Y00465	127
QCSM-26R	7.Y00464	127
QCSM-21/26G	7.Y02117	128
QCSM-32R	7.Y02095	129
QCSM-32G	7.Y02096	129
QCSM-08R	7.Y00477	131
QCSM-08G	7.Y00478	131
QCSM-08R-1000	7.Y02084	132
QCSM-08G-1000	7.Y02085	132
QCHFM-E14-C1R	7.Y02003	133
QCHFM-E14-C1G	7.Y02004	133
QCHFM-02R-1000	7.Y02086	134
QCHFM-02G-1000	7.Y02087	134
QCSM-08R1	7.Y02080	135
QCSM-08G1	7.Y02081	135
QCSM-12R	7.Y02082	136
QCSM-12G	7.Y02083	136
QCSM-06/11R	7.Y02673	137
QCSM-06/11G	7.Y02674	137
H032008FY	1.Y03689	137
H032012EFY	1.Y03690	137
H032008MY	1.Y03691	137
H032012PMY	1.Y03692	137
QCSM-06/11R1-5000	7.Y02675	138
QCSM-06/11G1-1000	7.Y02676	138
QCSM-RJ45-06R	7.Y02007	139



# 索引 Index

型号(Model)	货号(PN)	页码(Page)
QCSM-RJ45-06G	7.Y02008	139
YM110Fm01S1-01	1.Y13684	140
QCSM-RJ45-1M-06R	7.Y02129	141
QCSM-RJ45-1M-06G	7.Y02130	141
QCSM-05G7/8-04G7/8-10R	7.Y02115	142
QCSM-05G7/8-04G7/8-10G	7.Y02075	142
QCSM-05G7/8-04M12-10R	7.Y02118	143
QCSM-05G7/8-04M12-10G	7.Y02119	143
QCAM-01G02R	7.Y03893	144
QCAM-01G02G	7.Y03894	144
QCAM-06G18R	7.Y01015	145
QCAM-06G18G	7.Y01016	145
QCAM-06G18R-E	7.Y01018	146
QCAM-06G18G-E	7.Y01019	146
QCAM-06G18R-F	7.Y02005	147
QCAM-06G18G-F	7.Y02006	147
QCAM-10M5R	7.Y01053	148
QCAM-10M5G	7.Y01054	148
QCAM-14M5R	7.Y01055	149
QCAM-14M5G	7.Y01056	149
QCAM-04G38R	7.Y02043	150
QCAM-04G38G	7.Y02044	150
QCWM-02R	7.Y02049	151
QCWM-02G	7.Y02050	151
DB15R1-1000	1.Y10163	152
DB15G1-1000	1.Y10437	152
D-Sub15R2-1000	1.Y10080	153
D-Sub15G2-1000	1.Y10081	153
CMB08E-14-19S(072)SR-B	1.Y11863	154
CMB08E-14-19P(072)SR-B	1.Y11864	154
CMB08E-16-26S(072)SR-B	1.Y11865	155
CMB08E-16-26P(072)SR-B	1.Y11866	155
3108A22-23S	1.Y10710	156
3108A22-23P	1.Y10711	156
MS3116F14-19S	1.Y11420	157
MS3116F14-19S-Y	1.Y11420-Y	157
MS3116F14-19P	1.Y11419	157
MS3116F14-19P-Y	1.Y11419-Y	157
MS3116F16-26S	1.Y11867	158
MS3116F16-26S-Y	1.Y11867-Y	158
MS3116F16-26P	1.Y11369	158
MS3116F16-26P-Y	1.Y11369-Y	158
MS3116F22-36S	1.Y13392	159
MS3116F22-36P	1.Y13394	159
MS3118F22-36S	1.Y13393	160
MS3118F22-36P	1.Y13395	160
QCA-S350R-SP	8.Y01009	163
QCA-S350G	8.Y01010	163
QCA-S500R-SP	8.Y01015	165
QCA-S500G	8.Y01016	165
QCWM-02R1	7.Y02270	168
QCWM-02G1	7.Y02271	168
QCWM-04R1	7.Y02071	169
QCWM-04G1	7.Y02072	169
QCSM-03R	7.Y02069	170
QCSM-03G	7.Y02070	170
QCAM-08G38R	7.Y02051	171
QCAM-08G38G	7.Y02052	171
QCBM-508R	7.Y02073	172
QCBM-508G	7.Y02074	172
QCSM-081926R-A	7.Y02090	173
QCSM-081926G-A	7.Y02091	173
QCSM-081926R-Y	7.Y03864	174
QCSM-081926G-Y	7.Y03865	174
QCSM-081926R-K	7.Y03866	174
QCSM-081926G-K	7.Y03867	174
QCSM-081926R-F	7.Y03868	174

型号(Model)	货号(PN)	页码(Page)
QCSM-081926G-F	7.Y03869	174
QCSM-M9K	7.Y00922	176
QCSM-9R2	7.Y00862	176
QCSM-9G2	7.Y00863	176
R9-1000	1.Y06423	176
G9-1000	1.Y06424	176
QC-R50K	8.Y00402	177
QC-G50	8.Y00055	177
QCSM-9R1	7.Y00823	177
QCSM-9G1	7.Y00824	177
SIP-50B	7.Y00650	179
QC-R90K	8.Y00359	180
QC-G90	8.Y00033	180
QCSM-9R2	7.Y00862	180
QCSM-9G2	7.Y00863	180
QCX90-A	8.Y01391	182
QC-G90(G)	8.Y00033(G)	182
SIP-90B	7.Y00634	184
QC-R150K	8.Y00376	185
QC-G150	8.Y00377	185
QCSM-9R3	7.Y00819	185
QCSM-9G3	7.Y00820	185
QCX150-A	8.Y01392	187
QC-R160K	8.Y00360	188
QC-G160	8.Y00053	188
SIP-160B	7.Y00635	190
QC-R200K	8.Y00209	191
QC-G200	8.Y00208	191
QCSM-9R4	7.Y00821	191
QCSM-9G4	7.Y00822	191
QCX200-A	8.Y01393	193
SIP-200B	7.Y00865	194
QC-R09	8.Y01237	195
QC-G09	8.Y01238	195
QC-R11	8.Y01239	196
QC-G11	8.Y01240	196
QC-R18	8.Y01241	197
QC-G18	8.Y01242	197
QC-R36	8.Y01243	198
QC-G36	8.Y01244	198
QC-R43	8.Y01245	199
QC-G43	8.Y01246	199
QC-R58	8.Y01247	202
QC-G58	8.Y01248	200
QCS-R60	8.Y00081	201
QCS-G60	8.Y00082	201
KCH04-M5	1.Y03525	201
KCH06-M5	1.Y03524	201
QCS-R100	7.Y00332	202
QCS-G100	7.Y00175	202
KCH04-M5*5	7.Y00860	202
KCH06-M5*5	7.Y00861	202
MS-10SF*5	7.Y00334	202
MS-10PF	1.Y04667	202
QCS-R160	7.Y00160	203
QCS-G160	7.Y00161	203
KCH104-M5*5	7.Y02016	203
KCH106-M5*5	7.Y02017	203
MS-10SF*5	7.Y02018	203
MS-10PF	1.Y20004	203
QCL15R-Y	1.Y01275	204
QCL15G-Y	1.Y01276	204
QCL15R-S	8.Y00236	205
QCL15G-S	8.Y00235	205
QCL35R-S	8.Y00101	206
QCL35G-S	8.Y00102	206
Bp90	4.Y00480	207

型号(Model)	货号(PN)	页码(Page)
BP135	4.Y00497	207
QCA-S10R	8.Y00037	208
QCA-S10G	8.Y00038	208
QCA-20R	8.Y01093	209
QCA-20G	8.Y01094	209
QCHFM-2R1-1000	7.Y02261	210
QCHFM-2G1-1000	7.Y02262	210
QCSM-08R2-1000	7.Y02127	211
QCSM-08G2-1000	7.Y02128	211
QCA-130R-K4N032682	8.Y01230	212
QCA-130G-K4N032684	8.Y01229	212
OFU-XYZ100	8.Y01235	213
OFU-XYZ125	8.Y01236	213
OFU-XYZ160	8.Y01260	213
<b>夹具组件 Rip Module</b>		
FPT-40B-1	8.Y01324	216
FPT-40B-1-S	8.Y01325	216
FPT-50B-1	8.Y01326	216
FPT-50B-1-S	8.Y01327	216
FPT-64B-1	8.Y01328	216
FPT-64B-1-S	8.Y01329	216
FPT-80B-1	8.Y01330	216
FPT-80B-1-S	8.Y01331	216
FPT-100B-1	8.Y01332	216
FPT-100B-1-S	8.Y01333	216
FPT-125B-1	8.Y01334	216
FPT-125B-1-S	8.Y01335	216
FPT-160B-1	8.Y01336	216
FPT-160B-1-S	8.Y01337	216
FPT-200B-1	8.Y01338	216
FPT-240B-1	8.Y01339	216
FCT-40B-1	8.Y01340	218
FCT-50B-1	8.Y01341	218
FCT-64B-1	8.Y01342	218
FCT-80B-1	8.Y01343	218
FCT-100B-1	8.Y01344	218
FCT-125B-1	8.Y01345	218
FCT-160B-1	8.Y01346	218
FCT-200B-1	8.Y01347	218
FCT-240B-1	8.Y01348	218
D-M9BL	1.Y00307	218
KQ2V06-01AS	1.Y13156	218
KQ2V08-01AS	1.Y13159	218
KQ2V06-02AS	1.Y13157	218
GMHC2-16S	1.Y02014	219
GMHC2-16D	1.Y05738	219
GMHC2-20S	1.Y02730	219
GMHC2-20D	1.Y04328	219
GMHS3-16D	1.Y04529	220
GMHS3-20D	1.Y04764	220
GMHS3-25D	1.Y05750	220
GMHZ2-10S	1.Y00258	222
GMHZ2-10D	1.Y00252	222
GMHZ2-16S	1.Y00257	222
GMHZ2-16D	1.Y00256	222
GMHZ2-20S	1.Y03080	222
GMHZ2-20D	1.Y02703	222
GMHZ2-25S	1.Y09884	222
GMHZ2-25D	1.Y09338	222
GMHZ2-32S	1.Y09885	222
GMHZ2-32D	1.Y09886	222
GMHZ2-40S	1.Y09887	222
GMHZ2-40D	1.Y09888	222
GMHZL2-10S	1.Y09405	224
GMHZL2-10D	1.Y07974	224
GMHZL2-16S	1.Y08175	224
GMHZL2-16D	1.Y08146	224



型号(Model)	货号(PN)	页码(Page)
GMHZL2-20S	1.Y09882	224
GMHZL2-20D	1.Y07975	224
GMHZL2-25S	1.Y09883	224
GMHZL2-25D	1.Y08802	224
GFPT-20S	8.Y01295	226
E2S-W15(PNP)	7.Y00800	227
E2S-W13(NPN)	7.Y00801	227
GRS08	8.Y00214	229
GRS08-CN	8.Y00011	229
GRS08-CP	8.Y00012	229
GRM12A	8.Y00103	230
GRM12A-CN	8.Y00009	230
GRM12A-CP	8.Y00010	230
GRM12B	8.Y00107	230
GRM12B-CN	8.Y00104	230
GRM12B-CP	8.Y00105	230
GRL12A	8.Y00108	231
GRL12A-CN	8.Y00001	231
GRL12A-CP	8.Y00002	231
GRX20	8.Y00213	232
GRX20-CN	8.Y00013	232
GRX20-CP	8.Y00014	232
MAP-8S2P1/F(PNP)	1.Y13685	233
MAP-8S2N1/F(NPN)	1.Y13686	233
MAP-8S1.5P1/F CP	1.Y13687	233
MAP-8S1.5N1/F CN	1.Y13688	233
GR05A-10	8.Y00348	236
GR10A-12	8.Y00268	237
GR10A-12-CP	8.Y00267	237
GR10A-12-CN	8.Y00305	237
GR10D-12	8.Y00370	238
GR10D-12-CP	8.Y00369	238
GR10D-12-CN	8.Y01034	238
GR12A-12	8.Y00048	239
GR12A-12-CP	8.Y00050	239
GR12A-12-CN	8.Y00091	239
GR12B-12	8.Y00245	240
GR12B-12-CP	8.Y00261	240
GR12B-12-CN	8.Y00262	240
GR10L-12	8.Y00307	241
GR12L-12	8.Y00308	241
GR10L-12-CP	8.Y01053	241
GR10L-12-CN	8.Y01054	241
GR12L-12-CP	8.Y01020	241
GR12L-12-CN	8.Y01021	241
GR12M-12	8.Y00419	242
GR12M-12-CP	8.Y00421	242
GR12M-12-CN	8.Y00420	242
GR10N-12	8.Y01011	243
GR12N-12	8.Y01012	243
GR10N-12-CP	8.Y01018	243
GR10N-12-CN	8.Y01019	243
GR12N-12-CP	8.Y01084	243
GR12N-12-CN	8.Y01083	243
GR20A-20	8.Y01349	246
GR20A-20-CP	8.Y01350	246
GR20A-20-CN	8.Y01351	246
GR20B-20	8.Y01352	247
GR20B-20-CP	8.Y01353	247
GR20B-20-CN	8.Y01354	247
GR20C-20	8.Y01355	248
GR20D-20	8.Y01356	249
GR20D-20-CP	8.Y01357	249
GR20D-20-CN	8.Y01358	249
GR20D-20M	8.Y01400	250
GR20D-20M-CP	8.Y01401	250
GR20D-20M-CN	8.Y01402	250

型号(Model)	货号(PN)	页码(Page)
GR20E-20	8.Y01359	251
GR20F-20	8.Y01360	252
GR20F-20-20-CP	8.Y01361	252
GR20F-20-20-CN	8.Y01362	252
GR20G-20	8.Y01363	253
GR20G-20-CP	8.Y01364	253
GR20G-20-CN	8.Y01365	253
GR20H-20	8.Y01366	254
GR20H-20-CP	8.Y01367	254
GR20H-20-CN	8.Y01368	254
GR20I-20	8.Y01369	255
GR20I-20-CP	8.Y01370	255
GR20I-20-CN	8.Y01371	255
GRP10B-12	8.Y01379	257
GRP10B-12-CP	8.Y00368	257
GRP10B-12-CN	8.Y01017	257
GRP10C-12-SV	8.Y01224	258
GRP12C-12-SV	8.Y01288	258
GRP10D-12	8.Y01253	259
GRP10F-12-SV	8.Y01287	260
GRP12F-12-SV	8.Y01285	260
GRP10M-12-CN	8.Y01293	261
GRP10M-12-CP	8.Y01119	261
GRP10N-12	8.Y01108	262
GRA20A	8.Y00391	264
GRA20A-CP	8.Y00392	264
GRA20A-CN	8.Y00393	264
GRA20B	8.Y01076	265
GRA20C-CP	8.Y00434	266
GRA20C-CN	8.Y00435	266
GRT20A	8.Y00257	268
GRT20A-CN	8.Y00258	268
GRT20A-CP	8.Y00259	268
GRT20B	8.Y00279	269
GRT20B-CN	8.Y00281	269
GRT20B-CP	8.Y00282	269
GRT20C	8.Y00316	270
GRT20D	8.Y00317	271
GRT20D-CP	8.Y01004	271
GRT20D-CN	8.Y00458	271
GRT20E	8.Y00318	272
GRT20E-CN	8.Y00339	272
GRT20E-CP	8.Y00340	272
GRT20F	8.Y01008	273
GRP32A	8.Y00278	276
GRP32A-CP	8.Y00462	276
GRP32A-CN	8.Y00463	276
GRP32B	8.Y00388	277
GRP32B-CP	8.Y00466	277
GRP32B-CN	8.Y00467	277
GRP32A-30	8.Y00315	278
GRP32A-30CP	8.Y00464	278
GRP32A-30CN	8.Y00465	278
GRP32B-30	8.Y00387	279
GRP32B-30CP	8.Y00399	279
GRP32B-30CN	8.Y00411	279
GRP32A-3020	8.Y00468	280
GRP32A-3020CP	8.Y00469	280
GRP32A-3020CN	8.Y00477	280
GRP32B-3020	8.Y00478	281
GRP32B-3020CP	8.Y00416	281
GRP32B-3020CN	8.Y00417	281
GRP32C	8.Y00412	282
GRP32C-30	8.Y00415	282
GRP32C-3020	8.Y00418	283
NR20A	8.Y01322	284

型号(Model)	货号(PN)	页码(Page)
NR20A-30	8.Y01323	284
GFM-A3V5	4.Y00500	287
GFM-A4V5	4.Y00501	287
GFM-A5V5	4.Y00502	287
GFM-A6V5	4.Y10951	287
GFM-A7V5	4.Y10952	287
GFM-A8V5	4.Y10953	287
GFM-B3V5	4.Y00503	287
GFM-B4V5	4.Y00504	287
GFM-B5V5	4.Y00505	287
GFM-B6V5	4.Y10954	287
GFM-B7V5	4.Y10955	287
GFM-B8V5	4.Y10956	287
GFM-C3V5	4.Y00506	287
GFM-C4V5	4.Y00507	287
GFM-C5V5	4.Y00508	287
GFM-C6V5	4.Y10957	287
GFM-C7V5	4.Y10958	287
GFM-C8V5	4.Y10959	287
A3	1.Y08421	288
A4	1.Y08422	288
A5	1.Y08423	288
A6	1.Y12918	288
A7	1.Y12919	288
A8	1.Y12920	288
B3	1.Y08424	288
B4	1.Y08425	288
B5	1.Y08426	288
B6	1.Y12921	288
B7	1.Y12922	288
B8	1.Y12923	288
C3	1.Y08427	288
C4	1.Y08428	288
C5	1.Y08429	288
C6	1.Y12924	288
C7	1.Y12925	288
C8	1.Y12926	288
GBS-2B-S01	4.Y00509	289
GBS-3B-S01	4.Y00510	289
GBS-4B-S01	4.Y00511	289
B-2B	1.Y08430	290
B-3B	1.Y08431	290
B-4B	1.Y08432	290
GSMP-2S	7.Y01028	291
GSMP-2L	7.Y01029	291
GSMP-3S	7.Y01030	291
GSMP-3L	7.Y01031	291
GSMP-4S	7.Y01032	291
GSMP-4L	7.Y01033	291
GSMP-5S	7.Y01034	291
GSMP-5L	7.Y01035	291
BMC-4G27[H]/SN	4.Y00543	292
BMC-4G27[HAS]/SN	4.Y00544	292
BML-4G272[H]/SN	4.Y00545	292
BML-4G27[HAS]/SN	4.Y00546	292
BMC-4G34[H]/SN	4.Y00547	292
BMC-4G34[HAS]/SN	4.Y00548	292
BML-4G34[H]/SN	4.Y00549	292
BML-4G34[HAS]/SN	4.Y00550	292
BMC-4G39[H]/SN	4.Y00551	292
BMC-4G39[HAS]/SN	4.Y00552	292
BML-4G39[H]/SN	4.Y00553	292
BML-4G39[HAS]/SN	4.Y00554	292
BMC-4G44[H]/SN	4.Y00555	292
BMC-4G44[HAS]/SN	4.Y00556	292
BML-4G44[H]/SN	4.Y00557	292
BML-4G44[HAS]/SN	4.Y00558	292



# 索引 Index

型号(Model)	货号(PN)	页码(Page)
BMC-4G51(H)/SN	4.Y00559	292
BMC-4G51(HAS)/SN	4.Y00560	292
BML-4G51(H)/SN	4.Y00561	292
BML-4G51(HAS)/SN	4.Y00562	292
BMC-4G58(H)/SN	4.Y00563	292
BMC-4G58(HAS)/SN	4.Y00564	292
BML-4G58(H)/SN	4.Y00565	292
BML-4G58(HAS)/SN	4.Y00566	292
BMC-4G64(H)/SN	4.Y00567	292
BMC-4G64(HAS)/SN	4.Y00568	292
BML-4G64(H)/SN	4.Y00569	292
BML-4G64(HAS)/SN	4.Y00570	292
BMC-2G1012(H)/SN	4.Y00571	293
BMC-2G1012(HAS)/SN	4.Y00572	293
BML-2G1012(H)/SN	4.Y00573	293
BML-2G1012(HAS)/SN	4.Y00574	293
BMC-2G1622(H)/SN	4.Y00575	293
BMC-2G1622(HAS)/SN	4.Y00576	293
BML-2G1622(H)/SN	4.Y00577	293
BML-2G1622(HAS)/SN	4.Y00578	293
BMC-2G2027(H)/SN	4.Y00579	293
BMC-2G2027(HAS)/SN	4.Y00580	293
BML-2G2027(H)/SN	4.Y00581	293
BML-2G2027(HAS)/SN	4.Y00582	293
BMC-2G2032(H)/SN	4.Y00583	293
BMC-2G2032(HAS)/SN	4.Y00584	293
BML-2G2032(H)/SN	4.Y00585	293
BML-2G2032(HAS)/SN	4.Y00586	293
BMC-2G2037(H)/SN	4.Y00587	293
BMC-2G2037(HAS)/SN	4.Y00588	293
BML-2G2037(H)/SN	4.Y00588	293
BML-2G2037(HAS)/SN	4.Y00590	293
BMC-2G2042(H)/SN	4.Y00591	293
BMC-2G2042(HAS)/SN	4.Y00592	293
BML-2G2042(H)/SN	4.Y00593	293
BML-2G2042(HAS)/SN	4.Y00594	293
BMC-2G2047(H)/SN	4.Y00595	293
BMC-2G2047(HAS)/SN	4.Y00596	293
BML-2G2047(H)/SN	4.Y00597	293
BML-2G2047(HAS)/SN	4.Y00598	293
BMC-2G2052(H)/SN	4.Y00599	293
BMC-2G2052(HAS)/SN	4.Y00600	293
BML-2G2052(H)/SN	4.Y00601	293
BML-2G2052(HAS)/SN	4.Y00602	293
BMC-2G2057(H)/SN	4.Y00603	293
BMC-2G2057(HAS)/SN	4.Y00604	293
BML-2G2057(H)/SN	4.Y00605	293
BML-2G2057(HAS)/SN	4.Y00606	293
LCU-S_A	1.Y02564	294
LCU-S2_A	1.Y02566	296
LCU-S3_A	1.Y02567	296
LCU-S4_A	1.Y02568	296
LCU-S5_A	1.Y02569	296
LCU-S6_A	1.Y02570	296
LCU-S7_A	1.Y02571	296
LCU-S8_A	1.Y02572	296
LCU-S9_A	1.Y02573	296
LCU-S10_A	1.Y02574	296
LCU-H_A	1.Y02575	298
LCU-H_B	1.Y02576	298
iPCU2-SMV	1.Y02560	300
iPCU2-SMN	1.Y12927	300
iPCU2-HMV	1.Y02561	300
iPCU2-HMN	1.Y02562	300
ACU2-H	1.Y02563	302
GBD18U	8.Y00212	305
GBD22HU	8.Y00058	305

型号(Model)	货号(PN)	页码(Page)
GBD18HD	8.Y00057	305
GBD25HD	8.Y01256	305
18-S1	4.Y00470	306
18-S2	4.Y00472	306
22-S1	4.Y00471	306
22-S2	4.Y00473	306
GNT-4017	8.Y01249	307
GSRT1421-08	8.Y00242	308
GSRT2026-10	8.Y00332	308
GSRT2026-12	8.Y00244	308
GSRT2051-10	8.Y00333	308
GSRT2051-12	8.Y00334	308
GSR1421-08	8.Y00241	308
GSR1421-08	8.Y00373	308
GSR2026-10	8.Y00329	308
GSR2026-12	8.Y00243	308
GSR2051-10	8.Y00330	308
GSR2051-12	8.Y00331	308
GSP20-14	8.Y00238	309
GSP20-20	8.Y00239	309
GSP30-30	8.Y01032	309
GSP20-20C	8.Y01079	309
GSP30-30C	8.Y01081	309
GMP14A	8.Y00408	310
GMP20A	8.Y00088	310
GMP30A	8.Y00089	310
GMP14B	8.Y00968	310
GMP20B	7.Y00726	310
GMP30B	7.Y00789	310
GLU20A	7.Y00894	311
GLU20B	7.Y00895	311
GN2010-S51	8.Y00341	313
GN2010-S21	8.Y00440	313
GN2010-8S51	8.Y00385	313
GN2010	8.Y00025	314
GN2010-8	8.Y00347	314
GN3003-4	8.Y01005	315
GN3003-8	8.Y01250	315
GN3003-4-15	8.Y01082	316
GN2002-32	8.Y01035	317
GFA14-35	8.Y00117	318
GFA20-35	8.Y00118	318
GFA30-35	8.Y00119	318
GFR14-95	8.Y00042	319
GFR20-95E	8.Y00311	319
GFR30-95	8.Y00095	319
GFR14-95G	8.Y00084	320
GFR20-95EG	8.Y00312	320
GFR30-95G	8.Y00096	320
GFR20-95S	8.Y00335	321
GFR30-95S	8.Y01273	321
GFR20-95SG	8.Y00336	322
GFR30-95SG	8.Y01301	322
GFR20-95L	8.Y00309	323
GFR30-95L	8.Y01006	323
GFR20-95LG	8.Y00310	324
GFR30-95LG	8.Y01299	324
GFS14-90G	8.Y01001	325
GFS20-90G	8.Y01002	325
GFS30-90G	8.Y01003	325
GFS20-90SG	8.Y01030	326
GFS30-90SG	8.Y01031	326
SIL-14G	4.Y00486	327
SIL-20G	4.Y00485	327
SIL-30G	4.Y00514	327
SIL-14G-HNBR	4.Y00486-HNBR	327
SIL-20G-HNBR	4.Y00485-HNBR	327

型号(Model)	货号(PN)	页码(Page)
SIL-30G-HNBR	4.Y00514-HNBR	327
SIL-14G-NBR	4.Y00486-NBR	327
SIL-20G-NBR	4.Y00485-NBR	327
SIL-30G-NBR	4.Y00514-NBR	327
SIL-14G-TPU	4.Y00486-TPU	327
SIL-20G-TPU	4.Y00485-TPU	327
SIL-30G-TPU	4.Y00514-TPU	327
SIL-14G-EPDM	4.Y00486-EPDM	327
SIL-20G-EPDM	4.Y00485-EPDM	327
SIL-30G-EPDM	4.Y00514-EPDM	327
GP3-20V	7.Y02104	328
GP3-14P	7.Y02266	328
GP3-14N	7.Y02267	328
GP3-20P	7.Y02102	328
GP3-20N	7.Y02103	328
GP3-30P	7.Y02269	328
GP3-30N	7.Y02268	328
GP1-20	7.Y00778	329
GP1-30	7.Y00779	329
GP2-14	7.Y00780	329
GP2-20	7.Y00781	329
GP2-30	7.Y00782	329
GP3-14	7.Y00783	329
GP3-20	7.Y00700	329
GP3-20L	7.Y00908	329
GP3-30	7.Y00785	329
GS-14	7.Y00786	330
GS-20	7.Y00787	330
GS-30	7.Y00788	330
GOF20-20-NBR	8.Y00396	331
GOF20-20-VMQ	8.Y00395	331
GOP20-20-NBR	8.Y00398	331
GOP20-20-VMQ	8.Y00397	331
D-M9B	1.Y00310	332
D-M9BL	1.Y00307	332
D-M9BV	1.Y02565	332
D-M9BVL	1.Y03843	332
D-M9N	1.Y00311	332
D-M9NL	1.Y00295	332
D-M9NV	1.Y00298	332
D-M9NVL	1.Y03598	332
D-M9P	1.Y00309	332
D-M9PL	1.Y02301	332
D-M9PV	1.Y00296	332
D-M9PVL	1.Y02964	332
D-MQ	1.Y00293	332
GFT30-90	8.Y01222	333
GFT40-90	8.Y01223	334
GFT50-90	8.Y01130	335
GFT60-90	8.Y01007	336
GFT80-90	8.Y01390	337
GFN20-90	8.Y00094	338
GFN30-90	8.Y00116	338
GNS-3050-S1	8.Y01398	339
GMAG-20	8.Y01088	340
<b>气动剪刀 Air Nipper</b>		
GT-NY05	1.Y00008	346
GT-NY05R	1.Y03612	346
GT-NY05-4	1.Y01317	346
GT-NY05R-4	1.Y06093	346
GT-NY10	1.Y00012	346
GT-NY10R	1.Y00010	346
GT-NY10-4	1.Y02532	346
GT-NY10R-4	1.Y06098	346
GT-NY15	1.Y00006	346
GT-NY15R	1.Y00007	346
GT-NY15-4	1.Y06099	346



气动剪刀 Air Ripper			型号(Model)	货号(PN)	页码(Page)	型号(Model)	货号(PN)	页码(Page)
GT-NY15R-4	1.Y06100	346	GT-NT10-6	1.Y06111	354	NKH10AJ	1.Y01474	374
GT-NY25	1.Y00004	346	GT-NT10R-6	1.Y06112	354	NKH10RAJ	1.Y06241	374
GT-NY25R	1.Y00005	346	GT-NT20	1.Y01648	354	GT-NTH05	1.Y02235	375
GT-NY25-6	1.Y06101	346	GT-NT20R	1.Y06113	354	GT-NTH10	1.Y01471	375
GT-NY25R-6	1.Y06102	346	GT-NT20-6	1.Y06114	354	NTH05AJ	1.Y02236	375
GT-NY03G	1.Y00013	347	GT-NT20R-6	1.Y06115	354	NTH10AJ	1.Y01472	375
GT-NY03GR	1.Y01115	347	NT03AJ	1.Y06116	355	GT-NS3	1.Y01269	377
GT-NY03G-4	1.Y06091	347	NT05AJ	1.Y03935	355	GT-NS5	1.Y01036	377
GT-NY03GR-4	1.Y06092	347	NT05AJH	1.Y06117	355	GT-NS7	1.Y01037	377
GT-NY10G	1.Y03559	347	NT05AJB	1.Y06118	355	GT-NS10L	1.Y01214	377
GT-NY10GR	1.Y06094	347	NE5AJ	1.Y06119	355	GT-NS20	1.Y00009	377
GT-NY10G-4	1.Y06095	347	NT10AJ	1.Y00040	355	GT-NS30	1.Y00002	377
GT-NY10GR-4	1.Y04500	347	NT10AJH	1.Y06120	355	GT-NS20H-1	1.Y06133	377
GT-NY10S	1.Y06096	348	NT10AJB	1.Y01099	355	GT-N3	1.Y05900	378
GT-NY25S	1.Y06097	348	NE10AJ	1.Y00064	355	GT-N5	1.Y06134	378
GT-NF05	1.Y01316	349	NT20AJ	1.Y03936	355	GT-N7	1.Y02077	378
GT-NF10	1.Y01532	349	NT20AJH	1.Y06121	355	GT-N10	1.Y06135	378
GT-NF15	1.Y01350	349	NT20AJB	1.Y06122	355	GT-N12	1.Y01531	378
GT-NY05P	8.Y01386	350	NT05AJL	1.Y04056	356	GT-N20	1.Y01436	378
GT-NY10P	8.Y00270	350	NT10AJL	1.Y00034	356	GT-N30	1.Y00003	378
GT-NY15P	8.Y00249	350	NT20AJL	1.Y01649	356	GT-NS0	1.Y06136	378
GT-NY25P	8.Y01387	350	NT03AJT	1.Y06123	356	GT-NR3	1.Y03036	379
NY03AJ	1.Y00044	351	NT05AJT	1.Y04955	356	GT-NR5	1.Y02105	379
NY03RAJ	1.Y01116	351	NT10AJT	1.Y01318	356	GT-NR7	1.Y03324	379
NY05AJ	1.Y00018	351	NT03AJY	1.Y06124	357	GT-NR10L	1.Y00015	379
NY05RAJ	1.Y03613	351	NT05AJY	1.Y06125	357	GT-NR20	1.Y00222	379
NY05AJB	1.Y06103	351	NT10AJY	1.Y06126	357	GT-NR30	1.Y00001	379
NY10AJ	1.Y00020	351	NT05AD	1.Y06127	357	GT-NR50	1.Y01349	379
NY10RAJ	1.Y00019	351	NT10AD	1.Y02608	357	NR10LST	1.Y06137	380
NY10AJB	1.Y00026	351	NT20AD	1.Y06128	357	NR20ST	1.Y02115	380
NY15AJ	1.Y00016	351	NT05AJV	1.Y06129	358	NR30ST	1.Y03140	380
NY15RAJ	1.Y00017	351	NT10AJV	1.Y06130	358	NR50ST	1.Y03141	380
NY15AJB	1.Y00043	351	NT05AE	1.Y01169	358	P-10L	1.Y06200	380
NY25AJ	1.Y00037	351	NT10AE	1.Y00022	358	P-20	1.Y04318	380
NY25RAJ	1.Y00039	351	GT-NK10	1.Y02665	359	P-30	1.Y04310	380
NY25AJB	1.Y00041	351	NK10AJ	1.Y02666	359	P-50	1.Y06201	380
NY03AJL	1.Y03558	351	GT-TC-02	1.Y03833	360	GT-NWR10	1.Y06143	381
NY05AJL	1.Y00023	351	GT-BH2060	8.Y00346	362	GT-NWR20	1.Y06144	381
NY10AJL	1.Y00021	351	GT-BH20	7.Y04411	362	GT-NWR30	1.Y06145	381
NY15AJL	1.Y00025	351	GT-N2010H-10	8.Y01070	363	GT-NWS1	1.Y06146	381
NY25AJL	1.Y00036	351	GT-N2010H-10(逆)	8.Y01258	363	GT-NWS10	1.Y02979	381
NY03AJT	1.Y03208	352	AHC32X50	1.Y02005	363	GT-NWS20	1.Y06147	381
NY05AJT	1.Y06104	352	GT-N30H-32	8.Y01389	364	GT-NWS30	-	381
NY10AJT	1.Y02234	352	N30-T	7.Y03886	364	GT-NB20(5-OSHI)	-	382
NY15AJT	1.Y00024	352	N30-D	7.Y03887	364	GT-NB20(5-HIKU)	-	382
NY10AD	1.Y05999	352	L37-14-5	7.Y03888	364	GT-NB20(10-OSHI)	-	382
NY15AD	1.Y01089	352	温控线	1.Y03689	364	GT-NB20(10-HIKU)	-	382
NY25AD	1.Y03989	352	加热管	7.Y03890	364	GT-NB30(10-HIKU)	-	382
NY05AH	1.Y04614	353	GT-N50H-40	8.Y00367	366	GT-NB20LW-10TM	1.Y06148	382
NY05RAH	1.Y06052	353	N54-T	7.Y00441	366	GT-NB30LW-10TM	1.Y04593	382
NY10AH	1.Y00027	353	N54-D	7.Y00442	366	GT-NB20LW-10SM	1.Y06149	382
NY15AH	1.Y00858	353	L54-5	2.Y05202	366	GT-NB30LW-10SM	1.Y06150	382
NY15RAH	1.Y01466	353	温控线	1.Y02628	366	N3AP	1.Y05931	383
NY25AH	1.Y00038	353	加热管	1.Y02629	366	N5AP	1.Y00077	383
NY25RAH	1.Y00076	353	GT-N80H-63	8.Y01055	368	N7AP	1.Y00955	383
NY05BJ	1.Y03784	353	L81-20.8-4	7.Y03905	368	N10AP	1.Y01444	383
NY05RBJ	1.Y03114	353	L80-12.7-25	7.Y03906	368	N10LAP	1.Y00956	383
GT-NT03	1.Y03933	354	L81-12.8-4.5	7.Y03907	368	N12AP	1.Y06167	383
GT-NT03R	1.Y06105	354	温控线	1.Y02002	368	N20AP	1.Y00060	383
GT-NT03-4	1.Y06106	354	加热管	1.Y02558	368	N30AP	1.Y00062	383
GT-NT03R-4	1.Y06107	354	GTC-001	8.Y01026	370	N3AE	1.Y03037	383
GT-NT05	1.Y01168	354	GTC-002	8.Y01027	370	N5AE	1.Y02106	383
GT-NT05R	1.Y06108	354	GT-NKH20XL-25	-	372	N7AE	1.Y03325	383
GT-NT05-4	1.Y04956	354	GT-NKH20XR-25	-	372	N20AE	1.Y00057	383
GT-NT05R-4	1.Y06109	354	GT-NKH20A-25	1.Y00087	373	N30AE	1.Y00061	383
GT-NT10	1.Y01098	354	GT-NKH20AR-25	1.Y00086	373	NW10AJ	1.Y06168	384
GT-NT10R	1.Y06110	354	GT-NKH10	1.Y04612	374	N20AJ	1.Y00056	384



# 索引 Index

型号(Model)	货号(PN)	页码(Page)		
N20AJB	1.Y00033	384		
NW20AJ	1.Y06169	384		
N30AJ	1.Y00059	384		
NW30AJ	1.Y06170	384		
N10LAJ141	1.Y01176	384		
N20AJL	1.Y00035	384		
N20AB39	1.Y00028	384		
N30AJ163	1.Y04313	384		
N30AJL	1.Y00067	384		
N7PF	1.Y06171	385		
N10LPF	1.Y06172	385		
N20PF	1.Y00065	385		
N30PF	1.Y00058	385		
N20AH	1.Y00032	385		
N20AML1498	1.Y00047	386		
N20AMR1499	1.Y00046	386		
N30AML1435	1.Y12111	386		
N30AMR1395	1.Y09947	386		
N10LAB152	1.Y06173	386		
N20AA27	1.Y00030	386		
N20AA239	1.Y00045	386		
N20AB360	1.Y00042	386		
N30AA114	1.Y00052	386		
N30ALS25	1.Y00050	387		
N20AE1205	-	387		
NR20-P	8.Y00113	389		
NR20-P-D1	8.Y00113-D1	389		
NR30-P	8.Y00237	389		
NR30-P-D1	8.Y00237-D1	389		
NR20-P-S	8.Y00454	390		
GT-NR30-N30PF_H	7.Y02260	391		
NS20-P	8.Y00079	392		
NS30-P	8.Y00080	392		
NS20-P-D1	7.Y03872	393		
GT-NR50-30	8.Y01388	394		
T-20	7.Y02001	395		
T-30	7.Y02002	395		
NT-2010TM-P	8.Y00006	396		
NT-2010SM-P	8.Y00003	396		
真空组件 Vacuum Module				
型号(Model)	NBR-SS(黑色)	SI-SS(透明)	HTI-60(蓝色)	页码(Page)
PFG-2-...	1.Y12953	1.Y12972	1.Y12991	398
PFG-3-5-...	1.Y12954	1.Y12973	1.Y12992	398
PFG-5-...	1.Y12955	1.Y12974	1.Y12993	398
PFG-6-...	1.Y12956	1.Y12975	1.Y12994	398
PFG-8-...	1.Y12957	1.Y12976	1.Y12995	398
PFG-10-...	1.Y12958	1.Y12977	1.Y12996	398
PFG-15-...	1.Y12959	1.Y12978	1.Y12997	398
PFG-20-...	1.Y12960	1.Y12979	1.Y12998	398
PFG-25-...	1.Y12961	1.Y12980	1.Y12999	398
PFG-30-...	1.Y12962	1.Y12981	1.Y13000	398
PFG-35-...	1.Y12963	1.Y12982	1.Y13001	398
PFG-40-...	1.Y12964	1.Y12983	1.Y13002	398
PFG-50-...	1.Y12965	1.Y12984	1.Y13003	398
PFG-60-...	1.Y12966	1.Y12985	1.Y13004	398
PFG-80-...	1.Y12967	1.Y12986	1.Y13005	398
PFG-95-...	1.Y12968	1.Y12987	1.Y13006	398
FGA-6-...	1.Y12937	1.Y12949	1.Y12951	399
FGA-11-...	1.Y12938	1.Y12288	1.Y12298	399
FGA-14-...	1.Y12939	1.Y12289	1.Y12299	399
FGA-16-...	1.Y12940	1.Y12290	1.Y12300	399
FGA-20-...	1.Y12941	1.Y12291	1.Y12301	399
FGA-22-...	1.Y12942	1.Y12292	1.Y12302	399
FGA-25-...	1.Y12943	1.Y12293	1.Y12303	399
FGA-33-...	1.Y12944	1.Y12294	1.Y12304	399
FGA-43-...	1.Y12945	1.Y12295	1.Y12305	399
FGA-53-...	1.Y12946	1.Y12296	1.Y12306	399

型号(Model)	NBR-SS(黑色)	SI-SS(透明)	HTI-60(蓝色)	页码(Page)
FGA-63-...	1.Y12947	1.Y12297	1.Y12307	399
FGA-78-...	1.Y12948	1.Y12950	1.Y12952	399
FG-3-...	1.Y12929	1.Y12931	1.Y12934	400
FG-4-...	1.Y12930	1.Y12932	1.Y12935	400
FG-5-...	1.Y12308	1.Y12319	1.Y12331	400
FG-7-...	1.Y12309	1.Y12320	1.Y12332	400
FG-9-...	1.Y12310	1.Y12321	1.Y12333	400
FG-12-...	1.Y12311	1.Y12322	1.Y12334	400
FG-14-...	1.Y12312	1.Y12323	1.Y12335	400
FG-18-...	1.Y12313	1.Y12324	1.Y12336	400
FG-20-...	1.Y12314	1.Y12325	1.Y12337	400
FG-25-...	1.Y12315	1.Y12326	1.Y12338	400
FG-32-...	1.Y12284	1.Y12327	1.Y11797	400
FG-42-...	1.Y12316	1.Y12328	1.Y12340	400
FG-52-...	1.Y12317	1.Y12329	1.Y12341	400
FG-62-...	1.Y12318	1.Y12330	1.Y12342	400
FG-88-...	1.Y12928	1.Y12933	1.Y12936	400
PFYN-2-...	7.Y02131	7.Y02147	7.Y02163	401
PFYN-3-5-...	7.Y02132	7.Y02148	7.Y02164	401
PFYN-5-...	7.Y02133	7.Y02149	7.Y02165	401
PFYN-6-...	7.Y02134	7.Y02150	7.Y02166	401
PFYN-8-...	7.Y02135	7.Y02151	7.Y02167	401
PFYN-10-...	7.Y02136	7.Y02152	7.Y02168	401
PFYN-15-...	7.Y02137	7.Y02153	7.Y02169	401
PFYN-20-...	7.Y02138	7.Y02154	7.Y02170	401
PFYN-25-...	7.Y02139	7.Y02155	7.Y02171	401
PFYN-30-...	7.Y02140	7.Y02156	7.Y02172	401
PFYN-35-...	7.Y02141	7.Y02157	7.Y02173	401
PFYN-40-...	7.Y02142	7.Y02158	7.Y02174	401
PFYN-50-...	7.Y02143	7.Y02159	7.Y02175	401
PFYN-60-...	7.Y02144	7.Y02160	7.Y02176	401
PFYN-80-...	7.Y02145	7.Y02161	7.Y02177	401
PFYN-95-...	7.Y02146	7.Y02162	7.Y02178	401
PFYN-120-...	1.Y12969	1.Y12988	-	401
PFYN-150-...	1.Y12970	1.Y12989	1.Y13008	401
PFYN-200-...	1.Y12971	1.Y12990	-	401
FSGA-6-...	7.Y02179	7.Y02191	7.Y02203	402
FSGA-11-...	7.Y02180	7.Y02192	7.Y02204	402
FSGA-14-...	7.Y02181	7.Y02193	7.Y02205	402
FSGA-16-...	7.Y02182	7.Y02194	7.Y02206	402
FSGA-20-...	7.Y02183	7.Y02195	7.Y02207	402
FSGA-22-...	7.Y02184	7.Y02196	7.Y02208	402
FSGA-25-...	7.Y02185	7.Y02197	7.Y02209	402
FSGA-33-...	7.Y02186	7.Y02198	7.Y02210	402
FSGA-43-...	7.Y02187	7.Y02199	7.Y02211	402
FSGA-53-...	7.Y02188	7.Y02200	7.Y02212	402
FSGA-63-...	7.Y02189	7.Y02201	7.Y02213	402
FSGA-78-...	7.Y02190	7.Y02202	7.Y02214	402
FSG-3-...	7.Y02215	7.Y02230	7.Y02245	403
FSG-4-...	7.Y02216	7.Y02231	7.Y02246	403
FSG-5-...	7.Y02217	7.Y02232	7.Y02247	403
FSG-7-...	7.Y02218	7.Y02233	7.Y02248	403
FSG-9-...	7.Y02219	7.Y02234	7.Y02249	403
FSG-12-...	7.Y02220	7.Y02235	7.Y02250	403
FSG-14-...	7.Y02221	7.Y02236	7.Y02251	403
FSG-18-...	7.Y02222	7.Y02237	7.Y02252	403
FSG-20-...	7.Y02223	7.Y02238	7.Y02253	403
FSG-25-...	7.Y02224	7.Y02239	7.Y02254	403
FSG-32-...	7.Y02225	7.Y02240	7.Y02255	403
FSG-42-...	7.Y02226	7.Y02241	7.Y02256	403
FSG-52-...	7.Y02227	7.Y02242	7.Y02257	403
FSG-62-...	7.Y02228	7.Y02243	7.Y02258	403
FSG-88-...	7.Y02229	7.Y02244	7.Y02259	403
SGON-4x2-...	1.Y13068	1.Y13079	1.Y13090	404
SGON-7x3.5-...	1.Y13069	1.Y13080	1.Y13091	404
SGON-12x4-...	1.Y13070	1.Y13081	1.Y13092	404
SGON-15x5-...	1.Y13071	1.Y13082	1.Y13093	404

型号(Model)	NBR-SS(黑色)	SI-SS(透明)	HTI-60(蓝色)	页码(Page)
SGON-18x6-...	1.Y13072	1.Y13083	1.Y13094	404
SGON-24x8-...	1.Y13073	1.Y13084	1.Y13095	404
SGON-30x10-...	1.Y13074	1.Y13085	1.Y13096	404
SGON-45x15-...	1.Y13075	1.Y13086	1.Y13097	404
SGON-60x20-...	1.Y13076	1.Y13087	1.Y13098	404
SGON-75x25-...	1.Y13077	1.Y13088	1.Y13098	404
SGON-90x30-...	1.Y13078	1.Y13089	1.Y13100	404
型号(Model)	SI(透明)	SP(海绵)	页码(Page)	
VSH-S2	1.Y07282	-	405	
VSH-S4	1.Y07283	-	405	
VSH-S6	1.Y07284	-	405	
VSH-S8	1.Y07285	-	405	
VSH-S10	1.Y07286	-	405	
VSH-S12	1.Y07287	-	405	
VSH-S15	1.Y07288	-	405	
VSH-S20	1.Y07289	-	405	
VSH-S25	1.Y07290	-	405	
VSH-S30	1.Y07291	-	405	
VSH-M4	1.Y07292	-	405	
VSH-M6	1.Y07293	-	405	
VSH-M8	1.Y07294	-	405	
VSH-M10	1.Y07295	1.Y12885	405	
VSH-M12	1.Y07296	1.Y12886	405	
VSH-M15	1.Y07297	1.Y12887	405	
VSH-M20	1.Y07298	1.Y07530	405	
VSH-M25	1.Y07299	1.Y12888	405	
VSH-M30	1.Y07300	1.Y07758	405	
VSH-M40	1.Y07301	1.Y07894	405	
VSH-M50	1.Y07302	1.Y07895	405	
VSH2-S4	1.Y0703	-	406	
VSH2-S6	1.Y07304	-	406	
VSH2-S8	1.Y07305	-	406	
VSH2-S10	1.Y07306	-	406	
VSH2-S12	1.Y07307	-	406	
VSH2-S15	1.Y07308	-	406	
VSH2-S20	1.Y07309	-	406	
VSH2-S25	1.Y07310	-	406	
VSH2-S30	1.Y07311	-	406	
VSH2-M6	1.Y07312	-	406	
VSH2-M8	1.Y07313	-	406	
VSH2-M10	1.Y07314	1.Y08294	406	
VSH2-M12	1.Y07315	1.Y08295	406	
VSH2-M15	1.Y07316	1.Y08296	406	
VSH2-M20	1.Y07317	1.Y07929	406	
VSH2-M25	1.Y07318	1.Y08349	406	
VSH2-M30	1.Y07319	1.Y08056	406	
VSH2-M35	1.Y07320	-	406	
VSH2-M40	1.Y07321	1.Y08104	406	
VSH2-M50	1.Y07322	1.Y08105	406	
VSH3-S6	1.Y07323	-	407	
VSH3-S8	1.Y07324	-	407	
VSH3-S10	1.Y07325	-	407	
VSH3-S12	1.Y07326	-	407	
VSH3-S15	1.Y07327	-	407	
VSH3-M8	1.Y07328	-	407	
VSH3-M10	1.Y07329	1.Y09163	407	
VSH3-M12	1.Y07330	1.Y09162	407	
VSH3-M15	1.Y07331	1.Y09161	407	
VSH3-M20	1.Y07332	1.Y08134	407	
VSH3-M25	1.Y07333	1.Y09065	407	
VSH3-M30	1.Y07334	1.Y08167	407	
VSH3-M40	1.Y07335	1.Y08168	407	
VSH3-M50	1.Y07336	1.Y08234	407	
型号(Model)	货号(PN)	页码(Page)		
SAF-30-G3/8AG	1.Y13010	408		
SAF-30-G3/8IG	1.Y13011	408		
SAF-40-G3/8AG	1.Y13012	408		



型号(Model)	货号(PN)	页码(Page)
SAF-40-G3/8IG	1.Y13013	408
SAF-50-G3/8AG	1.Y13014	408
SAF-50-G3/8IG	1.Y13015	408
SAF-60-G3/8AG	1.Y13016	408
SAF-60-G3/8IG	1.Y13017	408
SAF-80-G3/8AG	1.Y13018	408
SAF-80-G3/8IG	1.Y13019	408
SAF-100-G3/8AG	1.Y13020	408
SAF-100-G3/8IG	1.Y13021	408
SAF-125-G3/8IG	1.Y13023	408
SAOF-50x16-G3/8AG	1.Y13024	408
SAOF-50x16-G3/8IG	1.Y13025	408
SAOF-60x23-G3/8AG	1.Y13026	408
SAOF-60x23-G3/8IG	1.Y13027	408
SAOF-90x30-G3/8AG	1.Y13028	408
SAOF-90x30-G3/8IG	1.Y13029	408
SAOF-80x40-G3/8AG	1.Y13030	408
SAOF-80x40-G3/8IG	1.Y13031	408
SAOF-100x50-G3/8AG	1.Y13032	408
SAOF-100x50-G3/8IG	1.Y13033	408
SAOF-120x60-G3/8AG	1.Y13034	408
SAOF-120x60-G3/8IG	1.Y13035	408
SAOF-140x70-G3/8IG	1.Y13037	408
SAB-22-G3/8AG	1.Y13038	409
SAB-22-G3/8IG	1.Y13039	409
SAB-30-G3/8AG	1.Y13040	409
SAB-30-G3/8IG	1.Y13041	409
SAB-40-G3/8AG	1.Y13042	409
SAB-40-G3/8IG	1.Y13043	409
SAB-50-G3/8AG	1.Y13044	409
SAB-50-G3/8IG	1.Y13045	409
SAB-60-G3/8AG	1.Y13046	409
SAB-60-G3/8IG	1.Y13047	409
SAB-80-G3/8AG	1.Y13048	409
SAB-80-G3/8IG	1.Y13049	409
SAB-100-G3/8AG	1.Y13050	409
SAB-100-G3/8IG	1.Y13051	409
SAB-125-G3/8AG	1.Y13052	409
SAB-125-G3/8IG	1.Y13053	409
SAOB-60x30-G3/8AG	1.Y13054	409
SAOB-60x30-G3/8IG	1.Y13055	409
SAOB-80x40-G3/8AG	1.Y13056	409
SAOB-80x40-G3/8IG	1.Y13057	409
SAOB-110x55-G3/8AG	1.Y13058	409
SAOB-110x55-G3/8IG	1.Y13059	409
SAOB-140x70-G3/8IG	1.Y13061	409
VM02-G18	7.Y00703	410
VM04-G14	7.Y00709	410
VM06-G14	7.Y00768	410
VM07-G18	7.Y00767	410
VM08-M8	1.Y05275	410
VM09-M5	1.Y05274	410
VM10-G18	7.Y00902	411
VM11-G18	1.Y12762	411
VM11-M5	1.Y05327	411
VM12-M5	7.Y00762	411
VM13-M5	7.Y00761	411
VM14-M5	7.Y00760	411
VM15-G18	7.Y00759	412
VM16-G18	7.Y00758	412
VM17-G18	7.Y00757	412
VM18-M5	1.Y05314	412
VM20-G14	4.Y00058	412
VM21-M5	1.Y01986	412
VM22-M5	1.Y05790	413
VM23-G18	7.Y00900	413
VM24-G18	7.Y00898	413

型号(Model)	货号(PN)	页码(Page)
VM25-M3	7.Y00928	413
VM27-M5	1.Y01097	413
VM28-M8	7.Y00475	413
VM29-M5	7.Y01036	414
VM30-G18	7.Y01037	414
VM31-M5	7.Y01038	414
VM32-G18	7.Y01039	414
VM33-M5	7.Y01040	414
VM34-G18	7.Y01041	414
VM35-M5	7.Y01042	415
VM36-G18	7.Y01043	415
VM37-M5	7.Y01044	415
VM38-G18	7.Y01045	415
VM39-M5	7.Y01046	415
VM40-G18	7.Y01047	415
VM41-G14	7.Y01048	416
VM10-G18-F	7.Y02013	416
VM42-G14	7.Y02059	416
VM-G18M-M10M	7.Y00808	417
VM-G14M-M10M	7.Y00756	417
VM-G18M-M5F	7.Y00755	417
VM-G18M-M8F	7.Y00754	417
VM-M5M-M8F	7.Y00473	417
VM-M5M-G18F	7.Y00474	417
VM-G14M-M8F	7.Y00476	418
VFN1011-M5	8.Y00064	420
VFN1021-M5	8.Y00321	420
VFN1421-G18	8.Y00065	420
VFN1436-G18	8.Y00322	420
VFN2026-G18	8.Y00066	420
VFN2051-G18	8.Y00067	420
VFNT1011-M5	8.Y00068	420
VFNT1021-M5	8.Y00323	420
VFNT1421-G18	8.Y00204	420
VFNT1621-G18	8.Y00383	420
VFNT1436-G18	8.Y00324	420
VFNT1636-G18	8.Y00384	420
VFNT2026-G18	8.Y00205	420
VFNT2051-G18	8.Y00206	420
VFR1011-M5	8.Y00060	421
VFR1021-M5	8.Y00325	421
VFR1421-G18	8.Y00061	421
VFR1436-G18	8.Y00326	421
VFR2026-G18	8.Y00062	421
VFR2051-G18	8.Y00063	421
VFRT1011-M5	8.Y00074	421
VFRT1021-M5	8.Y00327	421
VFRT1421-G18	8.Y00075	421
VFRT1621-G18	8.Y00381	421
VFRT1436-G18	8.Y00328	421
VFRT1636-G18	8.Y00382	421
VFRT2026-G18	8.Y00076	421
VFRT2051-G18	8.Y00077	421
VM-05F05F	7.Y02101	422
VM-14F14F	7.Y02100	422
VM-18F18F	7.Y02099	422
VFE1011-M5	8.Y00070	423
VFE1021-M5	8.Y00371	423
VFE1421-G18	8.Y00071	423
VFE1436-G18	8.Y00372	423
VFE2026-G18	8.Y00072	423
VFE2051-G18	8.Y00073	423
VFET1011-M5	8.Y00069	423
VFET1021-M5	8.Y00374	423
VFET1421-G18	8.Y00228	423
VFET1621-G18	8.Y00379	423
VFET1436-G18	8.Y00375	423

型号(Model)	货号(PN)	页码(Page)
VFET1636-G18	8.Y00380	423
VFET2026-G18	8.Y00229	423
VFET2051-G18	8.Y00230	423
VFC2030-G18	8.Y00313	424
VFCT1620-M5	8.Y00277	424
VFCT2030-G18	8.Y00314	425
VFG20-10	8.Y00207	425
VFG20-20	8.Y00337	425
VFG30-20	8.Y00338	425
VFGD30-20	8.Y00451	425
VFST-5M10	8.Y00283	426
VFST-10M10	8.Y00284	426
VFST-20M10	8.Y00285	426
VFST-30M10	8.Y00286	426
VFS-0508	8.Y00287	426
VFS-0512	8.Y00288	426
VFS-1008	8.Y00289	426
VFS-1012	8.Y00007	426
VFS-2008	8.Y00290	426
VFS-2012	8.Y00008	426
VFS-3008	8.Y00291	426
VFS-3012	8.Y00292	426
VFMT-5M12	8.Y00293	426
VFMT-10M12	8.Y00294	426
VFMT-20M12	8.Y00295	426
VFMT-30M12	8.Y00296	426
VFM-0512	8.Y00297	426
VFM-0520	8.Y00298	426
VFM-1012	8.Y00299	426
VFM-1020	8.Y00300	426
VFM-2012	8.Y00301	426
VFM-2020	8.Y00302	426
VFM-3012	8.Y00303	426
VFM-3020	8.Y00304	426
VFRS-20M10-M5	4.Y00026	427
VFRS-20M16-G18	4.Y00023	427
VFM-4014-G18	1.Y01452	427
VFM-2020-G14	1.Y01451	427
VFL-20M17-G18	1.Y01453	427
VFMT-20M14-G18	8.Y00319	428
VFMT-40M14-G18	8.Y00320	428
VFHT-30M20-G38F-G18M	8.Y00409	428
VFH-30M20-G38F-G18M	8.Y00410	428
FSTE-G14-AG-75	8.Y01113	429
FSTE-G18-AG-25	8.Y01112	429
FSTE-M5-IG-20-VG	8.Y01111	429
SY5120-5LZD-01	1.Y02556	430
SY5220-5LZD-01	1.Y02557	430
SY5320-5LZD-01	1.Y02747	430
SS5Y5-20-2	1.Y02609	431
SS5Y5-20-3	1.Y02610	431
SS5Y5-20-4	1.Y02611	431
SS5Y5-20-5	1.Y02612	431
SS5Y5-20-6	1.Y02613	431
SS5Y5-20-7	1.Y02614	431
SS5Y5-20-8	1.Y02615	431
SS5Y5-20-9	1.Y02616	431
SS5Y5-20-10	1.Y02617	431
SS5Y5-20-11	1.Y02618	431
SS5Y5-20-12	1.Y02619	431
SS5Y5-20-13	1.Y02620	431
SS5Y5-20-14	1.Y02621	431
SS5Y5-20-15	1.Y02622	431
SS5Y5-20-16	1.Y02623	431
SS5Y5-20-17	1.Y02624	431
SS5Y5-20-18	1.Y02625	431
SS5Y5-20-19	1.Y02626	431



# 索引 Index

型号(Model)	货号(PN)	页码(Page)
SS5Y5-20-20	1.Y02627	431
COMPACT 10CE PNP	1.Y13064	432
COMPACT 10CE NPN	1.Y13279	432
COMPACT 20CE PNP	1.Y13062	435
COMPACT 20CE NPN	1.Y13063	435
VLCCLASSIC XI x 2	1.Y13065	437
PHILINE® vacuum generator MINI SI, 6-6 mm	1.Y13066	428
PHILINE® vacuum generator MINI SI, 8-8 mm	1.Y13067	428
SCPSb-07-S04-NC-VD	1.Y13276	441
SCPSb-10-S04-NC-VD	1.Y13277	441
SCPSb-15-S04-NC-VD	1.Y13278	441
<b>附件 Accessory Components</b>		
ASC-8A-B	8.Y00087	442
AJB4M8-3P-M12	4.Y00487	443
AJB4M8-3N-M12	4.Y00488	443
AJB8M8-3P-M16	4.Y00491	443
AJB8M8-3N-M16	4.Y00492	443
AJB8M8-3P-D2	4.Y00495	443
AJB8M8-3N-D2	4.Y00496	443
ELK8112-0/9	1.Y07461	445
M8-M03T	1.Y06722	445
ELK8-2M/P00	1.Y07462	445
M8-M03L	1.Y13391	445
DNLK14-14-2M/P00	1.Y07463	446
ARJ210-M5BG	1.Y05877	448
-	1.Y02592	449
2.8-60T	7.Y02671	449
5.5-60T	7.Y02672	449
APB-M3-Ø4	1.Y03145	450
APB-M5-Ø4	1.Y05008	450
APB-M5-Ø6	1.Y01986	450
APF-M3	1.Y06794	450
APF-M5	1.Y02510	450
APF-G18	1.Y00462	450
APF-G14	1.Y00463	450
APBL-M3-Ø4	1.Y13282	450
APBL-M5-Ø4	1.Y13283	450
APBL-M5-Ø6	1.Y13284	450
APBL-G18-Ø6	1.Y13285	450
KQ2H02-M3G	1.Y13101	451
KQ2H02-M5A	1.Y13102	451
KQ2H23-M3G	1.Y13103	451
KQ2H23-M5A	1.Y13104	451
KQ2H04-M3G	1.Y13105	451
KQ2H04-M5A	1.Y04451	451
KQ2H04-M6A	1.Y13106	451
KQ2H06-M5A	1.Y04452	451
KQ2H06-M6A	1.Y13107	451
KQ2H23-01AS	1.Y13108	451
KQ2H23-02AS	1.Y13109	451
KQ2H04-01AS	1.Y03599	451
KQ2H04-02AS	1.Y05147	451
KQ2H06-01AS	1.Y13110	451
KQ2H06-02AS	1.Y07090	451
KQ2H06-03AS	1.Y05164	451
KQ2H08-01AS	1.Y07162	451
KQ2H08-02AS	1.Y05101	451
KQ2H08-03AS	1.Y02228	451
KQ2H10-01AS	1.Y13111	451
KQ2H10-02AS	1.Y07142	451
KQ2H10-03AS	1.Y07632	451
KQ2H10-04AS	1.Y13112	451
KQ2H12-02AS	1.Y13113	451
KQ2H12-03AS	1.Y13114	451
KQ2H12-04AS	1.Y13115	451
KQ2H16-02AS	1.Y13116	451
KQ2H16-03AS	1.Y13117	451

型号(Model)	货号(PN)	页码(Page)
KQ2H16-04AS	1.Y13118	451
KQ2H02-00A	1.Y13119	452
KQ2H23-00A	1.Y13120	452
KQ2H04-00A	1.Y13121	452
KQ2H06-00A	1.Y13122	452
KQ2H08-00A	1.Y13123	452
KQ2H10-00A	1.Y13124	452
KQ2H12-00A	1.Y13125	452
KQ2H16-00A	1.Y13126	452
KQ2H02-23A	1.Y13127	452
KQ2H02-04A	1.Y13128	452
KQ2H23-04A	1.Y13129	452
KQ2H23-06A	1.Y13130	452
KQ2H04-06A	1.Y13131	452
KQ2H06-08A	1.Y13132	452
KQ2H08-10A	1.Y13133	452
KQ2H10-12A	1.Y13134	452
KQ2H12-16A	1.Y13135	452
KQ2L02-M3G	1.Y13136	453
KQ2L02-M5A	1.Y13137	453
KQ2L23-M3G	1.Y13138	453
KQ2L23-M5A	1.Y13139	453
KQ2L04-M3G	1.Y13140	453
KQ2L04-M5A	1.Y02599	453
KQ2L04-M6A	1.Y13141	453
KQ2L06-M5A	1.Y02345	453
KQ2L06-M6A	1.Y13142	453
KQ2L23-01AS	1.Y13143	453
KQ2L23-02AS	1.Y13144	453
KQ2L04-01AS	1.Y05151	453
KQ2L04-02AS	1.Y05751	453
KQ2L06-01AS	1.Y02343	453
KQ2L06-02AS	1.Y11935	453
KQ2L06-03AS	1.Y10180	453
KQ2L08-01AS	1.Y07560	453
KQ2L08-02AS	1.Y04922	453
KQ2L08-03AS	1.Y05070	453
KQ2L10-01AS	1.Y13145	453
KQ2L10-02AS	1.Y06994	453
KQ2L10-03AS	1.Y08074	453
KQ2L10-04AS	1.Y13146	453
KQ2L12-02AS	1.Y13147	453
KQ2L12-03AS	1.Y13148	453
KQ2L12-04AS	1.Y13149	453
KQ2L16-02AS	1.Y13150	453
KQ2L16-03AS	1.Y13151	453
KQ2L16-04AS	1.Y13152	453
KQ2V04-M5A	1.Y13153	454
KQ2V06-M5A	1.Y13154	454
KQ2V04-01AS	1.Y13155	454
KQ2V06-01AS	1.Y13156	454
KQ2V06-02AS	1.Y13158	454
KQ2V08-01AS	1.Y13159	454
KQ2V08-02AS	1.Y13157	454
KQ2V08-03AS	1.Y13160	454
KQ2V10-02AS	1.Y13161	454
KQ2V10-03AS	1.Y13162	454
KQ2V12-03AS	1.Y13163	454
KQ2V12-04AS	1.Y13164	454
KQ2V16-03AS	1.Y13165	454
KQ2V16-04AS	1.Y13166	454
KQ2T02-M3G	1.Y13167	455
KQ2T02-M5A	1.Y13168	455
KQ2T23-M3G	1.Y13169	455
KQ2T23-M5A	1.Y13170	455
KQ2T04-M3G	1.Y13171	455
KQ2T04-M5A	1.Y01536	455

型号(Model)	货号(PN)	页码(Page)
KQ2T04-M6A	1.Y13172	455
KQ2T06-M5A	1.Y03052	455
KQ2T06-M6A	1.Y13173	455
KQ2T23-01AS	1.Y13174	455
KQ2T23-02AS	1.Y13175	455
KQ2T04-01AS	1.Y13176	455
KQ2T04-02AS	1.Y13177	455
KQ2T06-01AS	1.Y05154	455
KQ2T06-02AS	1.Y13178	455
KQ2T06-03AS	1.Y13179	455
KQ2T08-01AS	1.Y13180	455
KQ2T08-02AS	1.Y13181	455
KQ2T08-03AS	1.Y13182	455
KQ2T10-01AS	1.Y13183	455
KQ2T10-02AS	1.Y13184	455
KQ2T10-03AS	1.Y13185	455
KQ2T10-04AS	1.Y13186	455
KQ2T12-02AS	1.Y13187	455
KQ2T12-03AS	1.Y13188	455
KQ2T12-04AS	1.Y13189	455
KQ2T16-02AS	1.Y13190	455
KQ2T16-03AS	1.Y13191	455
KQ2T16-04AS	1.Y13192	455
KQ2T02-00A	1.Y13193	456
KQ2T23-00A	1.Y13194	456
KQ2T04-00A	1.Y03077	456
KQ2T06-00A	1.Y03076	456
KQ2T08-00A	1.Y00761	456
KQ2T10-00A	1.Y13195	456
KQ2T12-00A	1.Y13196	456
KQ2T16-00A	1.Y13197	456
KQ2T23-04A	1.Y13198	456
KQ2T04-06A	1.Y04160	456
KQ2T06-08A	1.Y04159	456
KQ2T08-10A	1.Y07561	456
KQ2T10-12A	1.Y13199	456
KQ2T12-16A	1.Y13200	456
KQ2T06-04A	1.Y13201	456
KQ2T08-06A	1.Y13202	456
KQ2T10-08A	1.Y13203	456
KQ2T12-10A	1.Y13204	456
KQ2U02-00A	1.Y13205	457
KQ2U23-00A	1.Y13206	457
KQ2U04-00A	1.Y02601	457
KQ2U06-00A	1.Y02600	457
KQ2U08-00A	1.Y03078	457
KQ2U10-00A	1.Y13207	457
KQ2U12-00A	1.Y13208	457
KQ2U16-00A	1.Y13209	457
KQ2UD04-06A	1.Y06909	457
KQ2UD06-08A	1.Y08529	457
<b>型号(Model) 进气节流 排气节流 页码(Page)</b>		
AS12□1F-M5-02A	1.Y13218	1.Y13222 458
AS12□1F-M5-23A	1.Y13219	1.Y13223 458
AS12□1F-M5-04A	1.Y13220	1.Y13224 458
AS12□1F-M5-06A	1.Y13221	1.Y03830 458
AS22□1F-01-23SA	1.Y13225	1.Y13246 458
AS22□1F-01-04SA	1.Y13226	1.Y13247 458
AS22□1F-01-06SA	1.Y13227	1.Y05040 458
AS22□1F-01-08SA	1.Y13228	1.Y13248 458
AS22□1F-01-10SA	1.Y13229	1.Y13249 458
AS22□1F-02-23SA	1.Y13230	1.Y13250 458
AS22□1F-02-04SA	1.Y13231	1.Y13251 458
AS22□1F-02-06SA	1.Y13232	1.Y06906 458
AS22□1F-02-08SA	1.Y13233	1.Y08260 458
AS22□1F-02-10SA	1.Y13234	1.Y13252 458
AS32□1F-02-06SA	1.Y13235	1.Y13253 458



型号(Model)	进气节流	排气节流	页码(Page)
AS32□1F-02-08SA	1.Y13236	1.Y13254	458
AS32□1F-02-10SA	1.Y13237	1.Y13255	458
AS32□1F-02-12SA	1.Y13238	1.Y13256	458
AS32□1F-03-06SA	1.Y13239	1.Y13257	458
AS32□1F-03-08SA	1.Y13240	1.Y13258	458
AS32□1F-03-10SA	1.Y13241	1.Y13259	458
AS32□1F-03-12SA	1.Y13242	1.Y13260	458
AS42□1F-04-10SA	1.Y13243	1.Y13261	458
AS42□1F-04-12SA	1.Y13244	1.Y13262	458
AS42□1F-04-16SA	1.Y13245	1.Y13263	458
型号(Model)	货号(PN)	页码(Page)	
AS1002F-02	1.Y13264	459	
AS1002F-23	1.Y13265	459	
AS1002F-04	1.Y04457	459	
AS1002F-06	1.Y04777	459	
AS2002F-04	1.Y13266	459	
AS2002F-06	1.Y13267	459	
AS2052F-06	1.Y13268	459	
AS2052F-08	1.Y13269	459	
AS3002F-06	1.Y13270	459	
AS3002F-08	1.Y13271	459	
AS3002F-10	1.Y13272	459	
AS3002F-12	1.Y13273	459	
AS4002F-10	1.Y13274	459	
AS4002F-12	1.Y13275	459	
KCH04-M5	1.Y03525	460	
KCH04-01S	1.Y13286	460	
KCH06-M5	1.Y03524	460	
KCH06-01S	1.Y13287	460	
KCH08-01S	1.Y13288	460	
KJP-02	1.Y13210	460	
KQ2P-23	1.Y13211	460	
KQ2P-04	1.Y13212	460	
KQ2P-06	1.Y13213	460	
KQ2P-08	1.Y13214	460	
KQ2P-10	1.Y13215	460	
KQ2P-12	1.Y13216	460	
KQ2P-16	1.Y13217	460	
AH4B	1.Y00824	461	
AH4BU	1.Y03687	461	
AH4G	1.Y00823	461	
AH4T	1.Y03686	461	
AH4Y	1.Y00821	461	
AH4R	1.Y00822	461	
AH4O	1.Y05661	461	
AH6B	1.Y00830	461	
AH6BU	1.Y00829	461	
AH6G	1.Y00825	461	
AH6T	1.Y00827	461	
AH6Y	1.Y00828	461	
AH6R	1.Y00826	461	
AH6O	1.Y04640	461	
AH8B	1.Y04478	461	
AH8BU	1.Y00831	461	
AH10B	1.Y04476	461	
AH10BU	1.Y05660	461	



A series of horizontal dashed lines spanning the width of the page, intended for handwriting practice.



A series of horizontal dashed lines spanning the width of the page, intended for handwriting practice. There are 25 lines in total, evenly spaced from top to bottom.